



**Unit Model #: 56131501**

**Mower:** Spartan

**Owner's Manual:** Q0563

**Mower Type:** RT-Pro, RT-HD, SRT-XDe & SRT-XD

**Deck Size:** 54"

**Vac Type:** P3B (15 Cu. Ft.)

**Deck Type:**

**Drive Type:** PTO-X Driven

**Revision #:** 1 PTO-X 1.5 - 6/24/24 BS

**Fits Year(s):** 2018 & Newer

**A2311 Vac Kit**

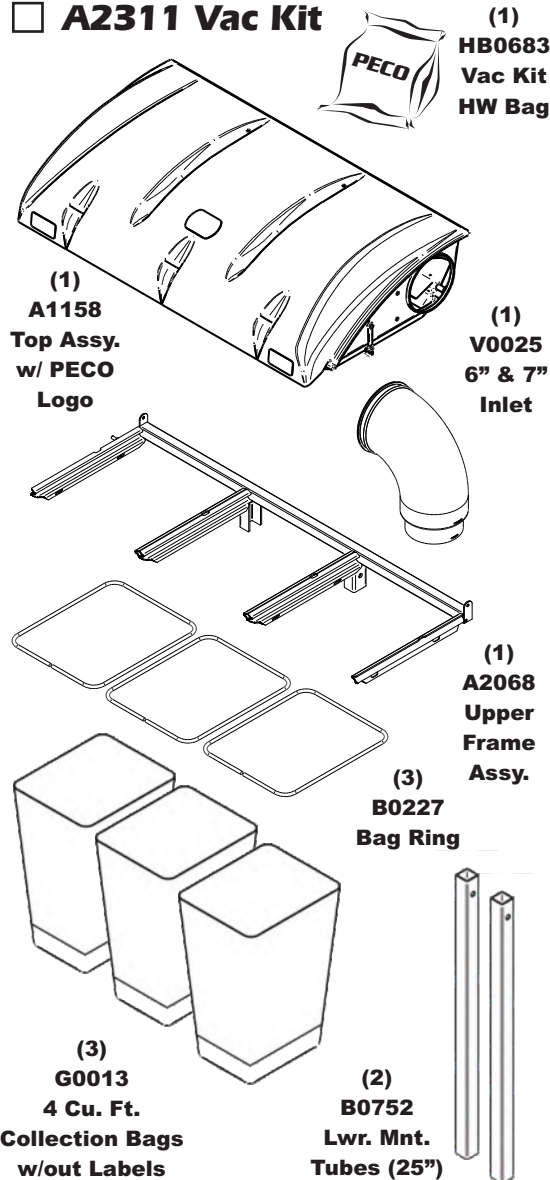

**A2317 Mount Kit**

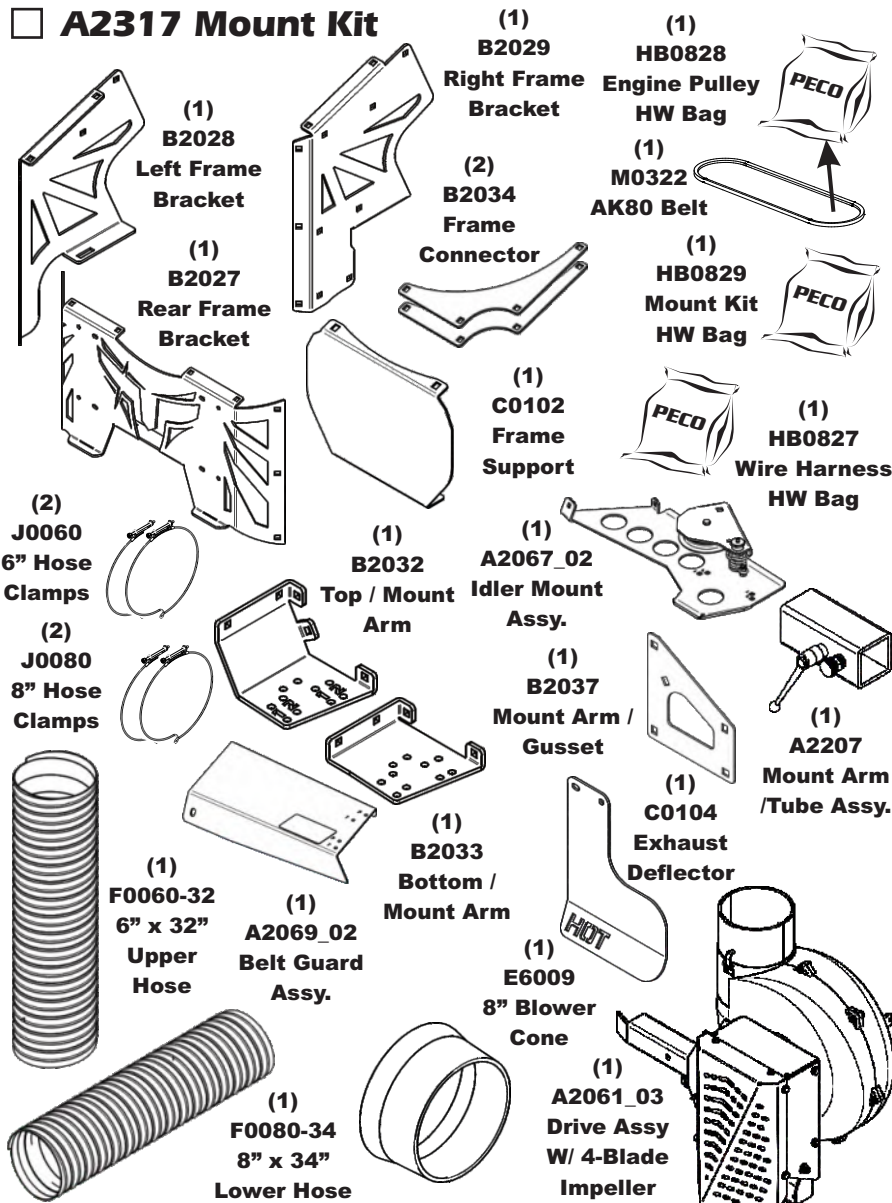

**A2313 Boot Kit**

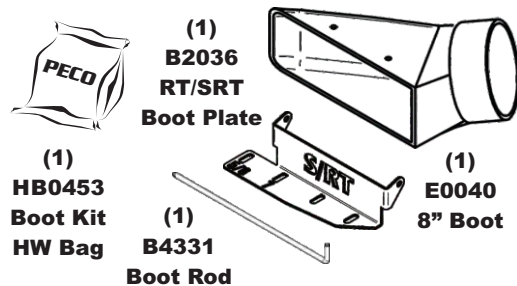

**A2162 Quad Weight Kit / Single Caster**

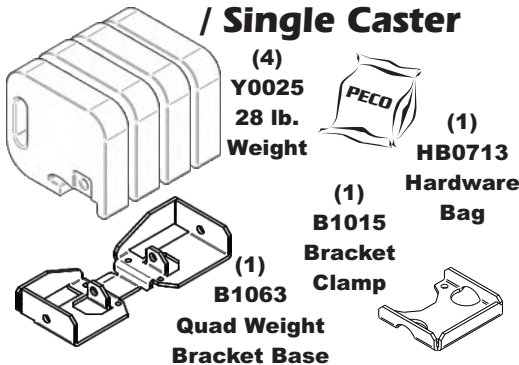

**A2121 Dual Weight Kit / Single Caster**

