



**Technical Service
BULLETIN**

May 04, 2022

Title: **Tightening the
Z-Trimmer Head**

Models: ZT-3000 & ZT-3001

TSB-0011

PRODUCT GENERAL INFO

INTRODUCTION: This bulletin provides information on how to properly tighten your Z-Trimmer Head and how to ensure that it stays properly tightened.

Note: Some parts and part features in the Figures throughout this bulletin will be hidden from view for visual clarity.

STEP 1:

Locate the 1/4" Set Screw securing your Shaft Nut to the shaft of the Electric Motor on your Z-Trimmer. Refer to Figure 1.

FIG. 1

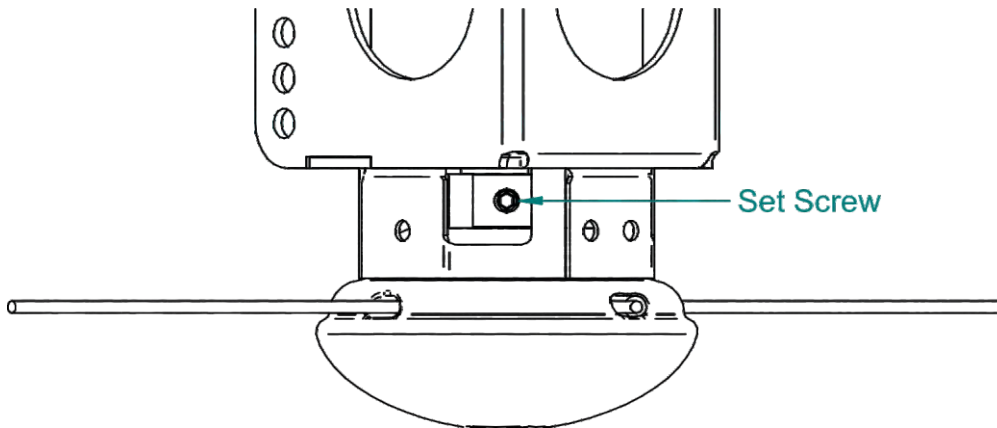

STEP 2:

Using an Allen Wrench, insert one end into the Set Screw & hold the Allen Wrench firmly to prevent the shaft of the Z-Trimmer Motor from turning. Refer to Figure 2.

FIG. 2

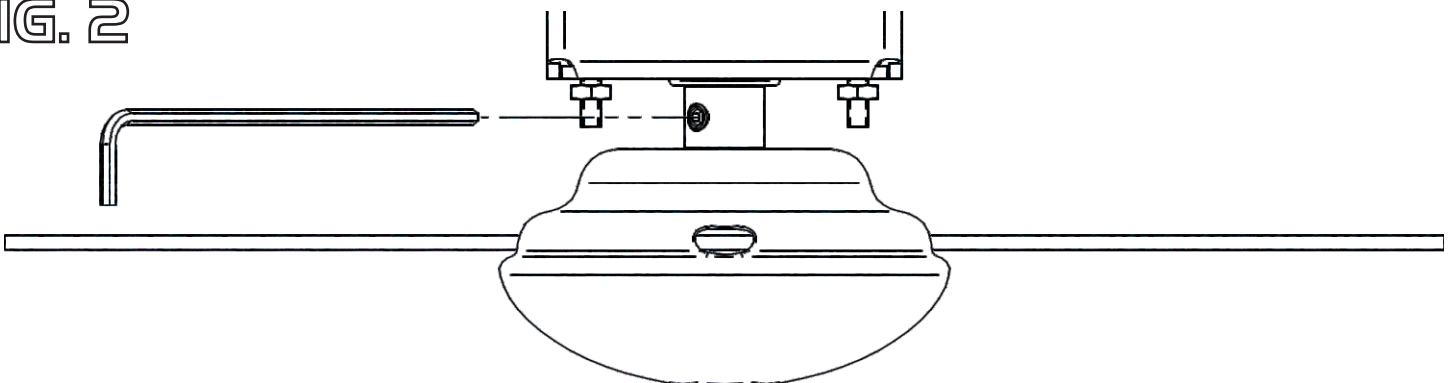

STEP 3:

Rotate the Z-Trimmer Head counter clockwise to tighten the Shaft Nut securing the Z-Trimmer Head. Refer to Figure 3.

FIG. 3

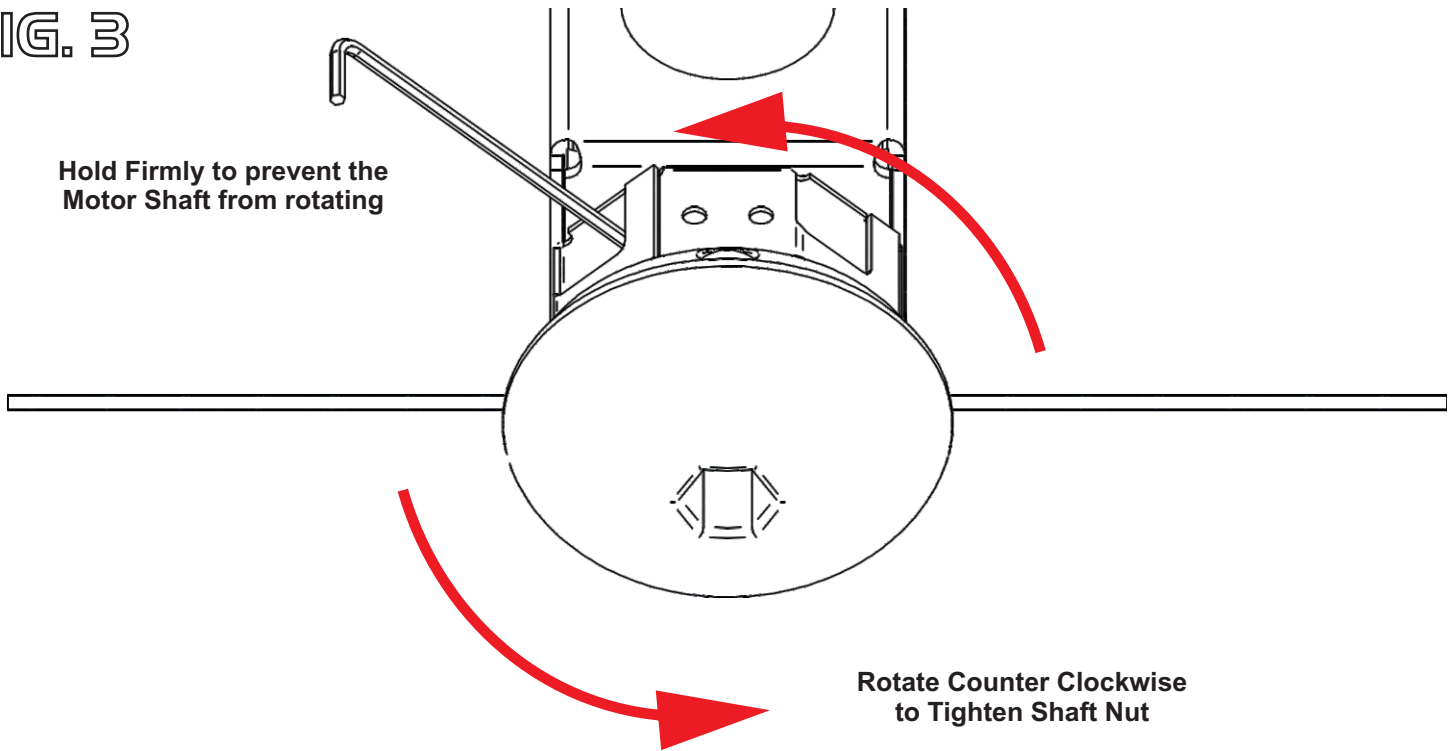

If you've noticed that your Z-Trimmer Head frequently loosens or if you have already tightened the Z-Trimmer Head as previously described but the Z-Trimmer Head still becomes loose, it is recommended to apply a Medium Strength Loctite (Loctite 242 - Blue) to secure the Shaft Bushing to the Shaft Nut. Please allow 10 minutes for the Loctite to set (Fully cures in 24 hours). Refer to Figure 4.

FIG. 4

