

# MODEL#: 43621207

MOWER NAME: **TEXTRON BUNTON**

MOWER MODEL: **BZT-2000 SERIES**

MOWER DECK SIZE: **61", 52" & 48" DECK**

VAC NAME: **12 CUBIC FOOT BOX**

**ENG: 900 SER. BR (9.00 GROSS TORQUE / 205 cc)**

**BILL OF MATERIAL: BOM0319**

**NOTE:**

**NOTE:**



FOR YEAR: 2007

REVISED: 5/8/2012

## **A0991 UNIT ASSY.**

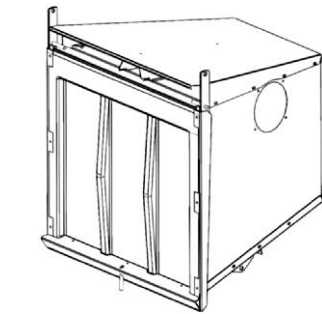

(1)  
**A0794**  
12 CU. FT.  
BOX ASSY.



(1)  
**V1054**  
6" PLASTIC  
INLET

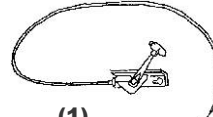

(1)  
**A0060**  
LONG THROTTLE KIT  
FOR 900 SERIES



(2)  
**J6006**  
7" - 8"  
HOSE CLAMPS



(1)  
**HB0332**  
HARDWARE  
BAG

(1)  
**6" x 32"**  
UPPER  
HOSE



(1)  
**7" x 48"**  
LOWER  
HOSE

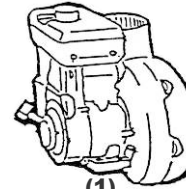

(1)  
**ENGINE/  
BLOWER/  
BLADE ASSY.**

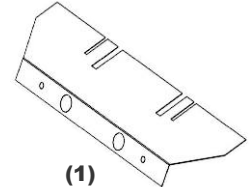

(1)  
**C0011**  
HEAT GUARD

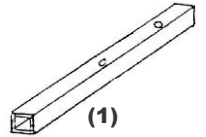

(1)  
**B1117**  
OUTER ENGINE  
MOUNT TUBE



(1)  
**A0273**  
BOX HANDLE

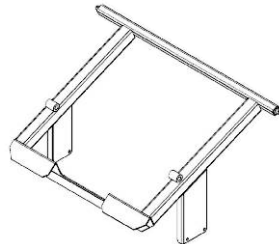

(1)  
**A0680**  
MAIN FRAME  
ASSY.

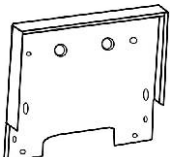

(1)  
**B0047**  
REAR MOUNT  
PLATE



(1)  
**E6004**  
7" BLOWER  
CONE



(1)  
**A0681**  
LT. LOWER  
FRAME LEG  
ASSY.

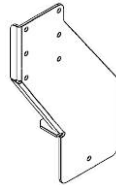

(1)  
**A0679**  
RT. LOWER  
FRAME LEG  
ASSY.

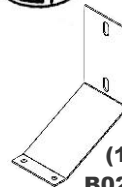

(1)  
**B0276**  
AIR CLEANER  
MOUNT BRACE

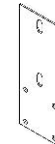

(1)  
**B0275**  
AIR CLEANER  
MOUNT PLATE

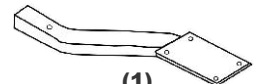

(1)  
**A0318**  
ENGINE MOUNT  
ARM ASSY.

## **A0683 WEIGHT KIT**



(1)  
**HB0120**  
HARDWARE  
BAG

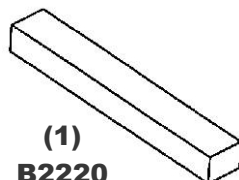

(1)  
**B2220**  
WEIGHT

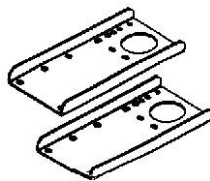

(2)  
**B0026**  
WEIGHT  
BRACKET

## **A0908 BOOT KIT**



(1)  
**HB0078**  
HARDWARE  
BAG

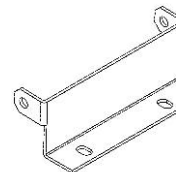

(1)  
**B0435**  
BOOT  
PLATE

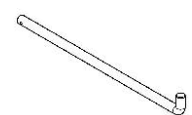

(1)  
**B0288**  
BOOT  
ROD

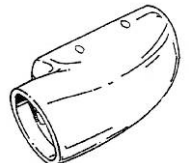

(1)  
**E1031**  
BOOT