

MODEL#: 37020901

MOWER NAME: SCAG

MOWER MODEL: FREEDOM Z

MOWER DECK SIZE: 48" DECK

VAC NAME: PRO 2 BAGGER

PTO DRIVEN

MANUAL #Q0412

A1789 UNIT ASSEMBLY

A1153 48" BAFFLE KIT



FOR YEAR: 2012-2010

Revision 1 4/4/2012

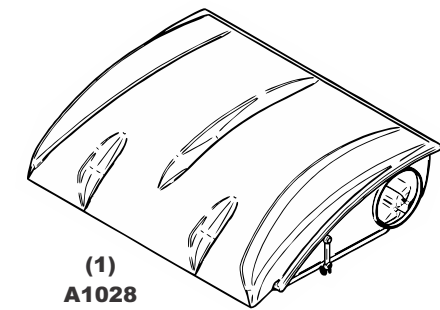

(1)
A1028
TOP ASSEMBLY



(1)
V0019
INLET



(4)
J1000
HOSE
CLAMPS

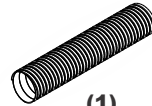

(1)
F0001
6" x 20"
UPPER HOSE

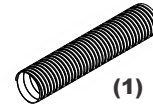

(1)
F0001
6" x 25"
LOWER HOSE



(1)
HB0429
UNIT
HARDWARE
BAG

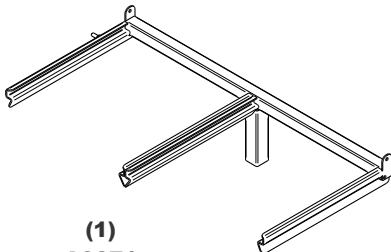

(1)
A0871
UPPER FRAME
ASSEMBLY

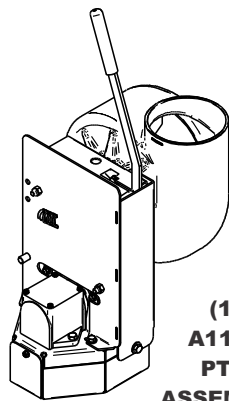

(1)
A1111
PTO
ASSEMBLY

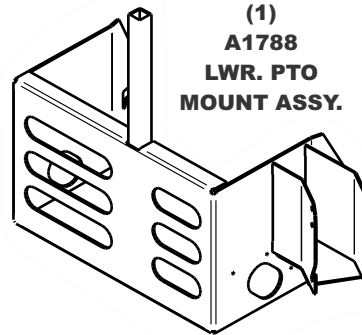

(1)
A1788
LWR. PTO
MOUNT ASSY.

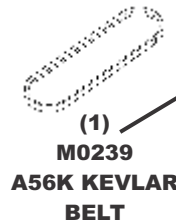

(1)
M0239
A56K KEVLAR
BELT



(1)
HB0430
ENGINE PULLEY
HARDWARE
BAG

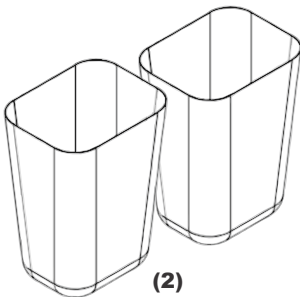

(2)
G0004
2.9 CU. FT.
COLLECTION
BAGS

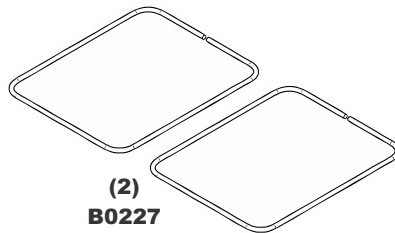

(2)
B0227
BAG RING



(1)
V0016
BLOWER
CONE 6"

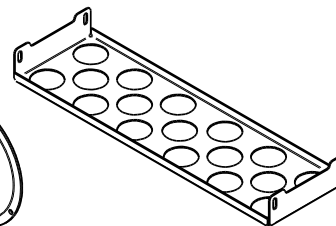

(1)
B0632
HEAT
SHIELD

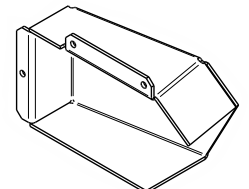

(1)
C0064
EXHAUST
DEFLECTOR

A1790 BOOT KIT



(1)
HB0432
HARDWARE
BAG

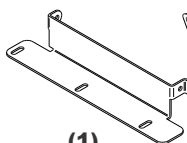

(1)
B0577
BOOT PLATE

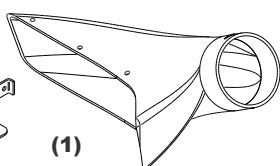

(1)
V0027
BOOT



(1)
B4331
BOOT ROD

A1791 WEIGHT KIT

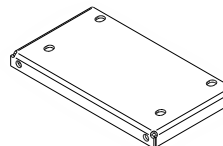

(1)
B0576
WEIGHT
BRACKET

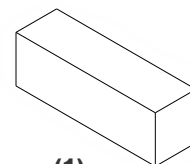

(1)
B0034
12" WEIGHT
BAR



(1)
HB0431
HARDWARE
BAG