

# MODEL#: 23020908

MOWER NAME: BOB-CAT

MOWER MODEL: FAST CAT F & G-SERIES

MOWER DECK SIZE: 42" AND 61" DECKS

VAC NAME: PRO 2 BAGGER

PTO DRIVEN

MANUAL #Q0387

A1090 UNIT ASSEMBLY



FOR YEAR: 2012 - 2008

REVISED: 10/10/2012

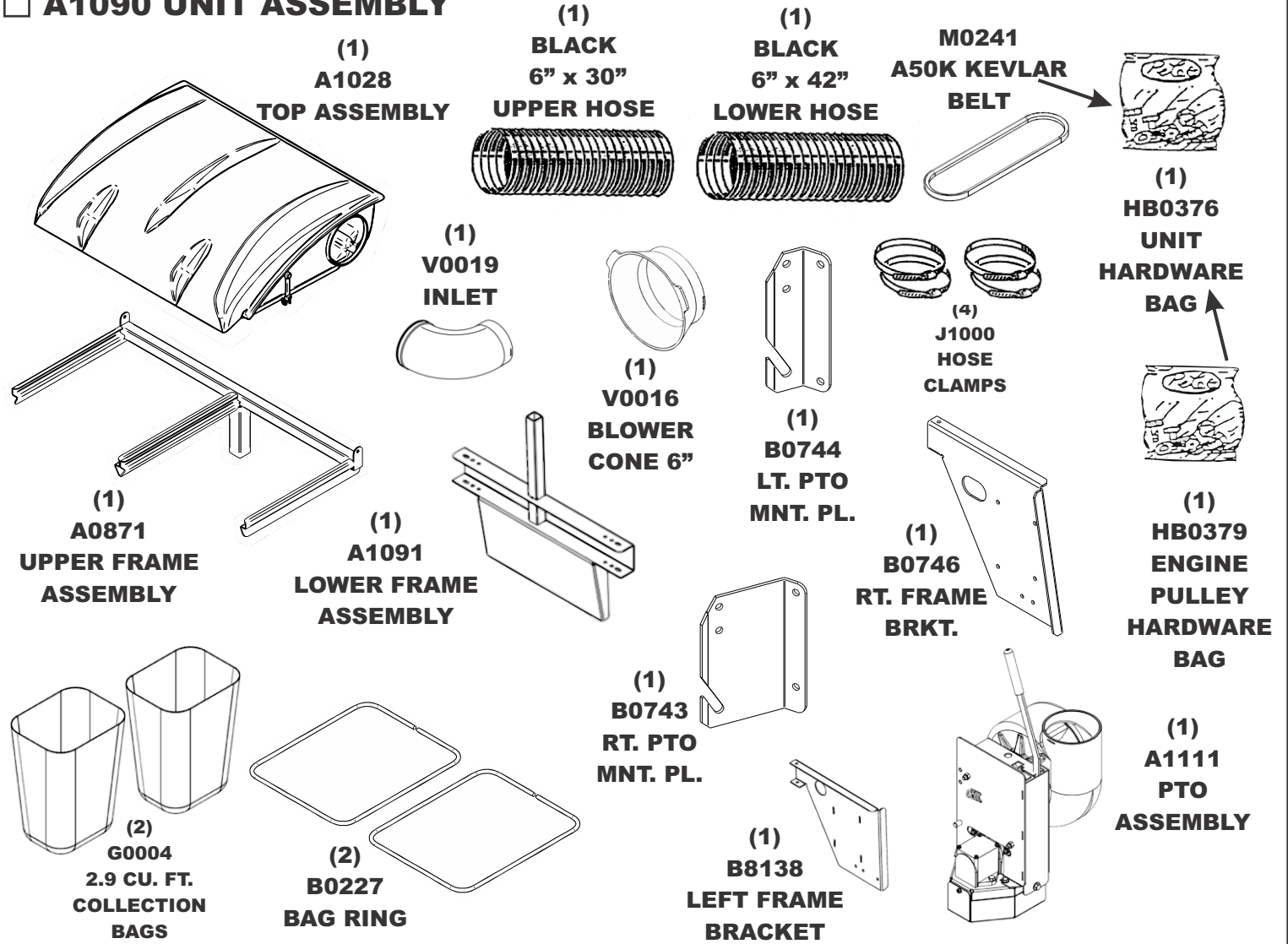

A1743 BOOT KIT

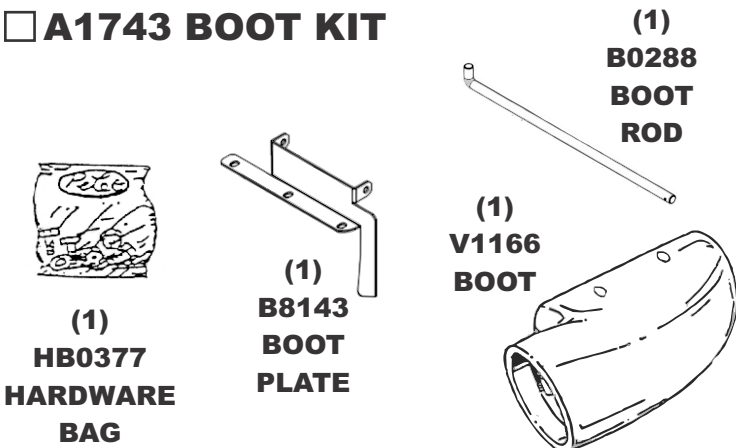

A1094 WEIGHT KIT

