

# MODEL#: 47020901 (GC250)

MOWER NAME: BUSH HOG

MOWER MODEL: HS SERIES

MOWER DECK SIZE: 36" & 42" DECK

VAC NAME: 9 CUBIC FOOT PRO BAGGER

DIRECT FLOW

BILL OF MATERIALS: BOM0329



FOR YEAR: 2008

REVISED:

## A1026 UNIT ASSEMBLY

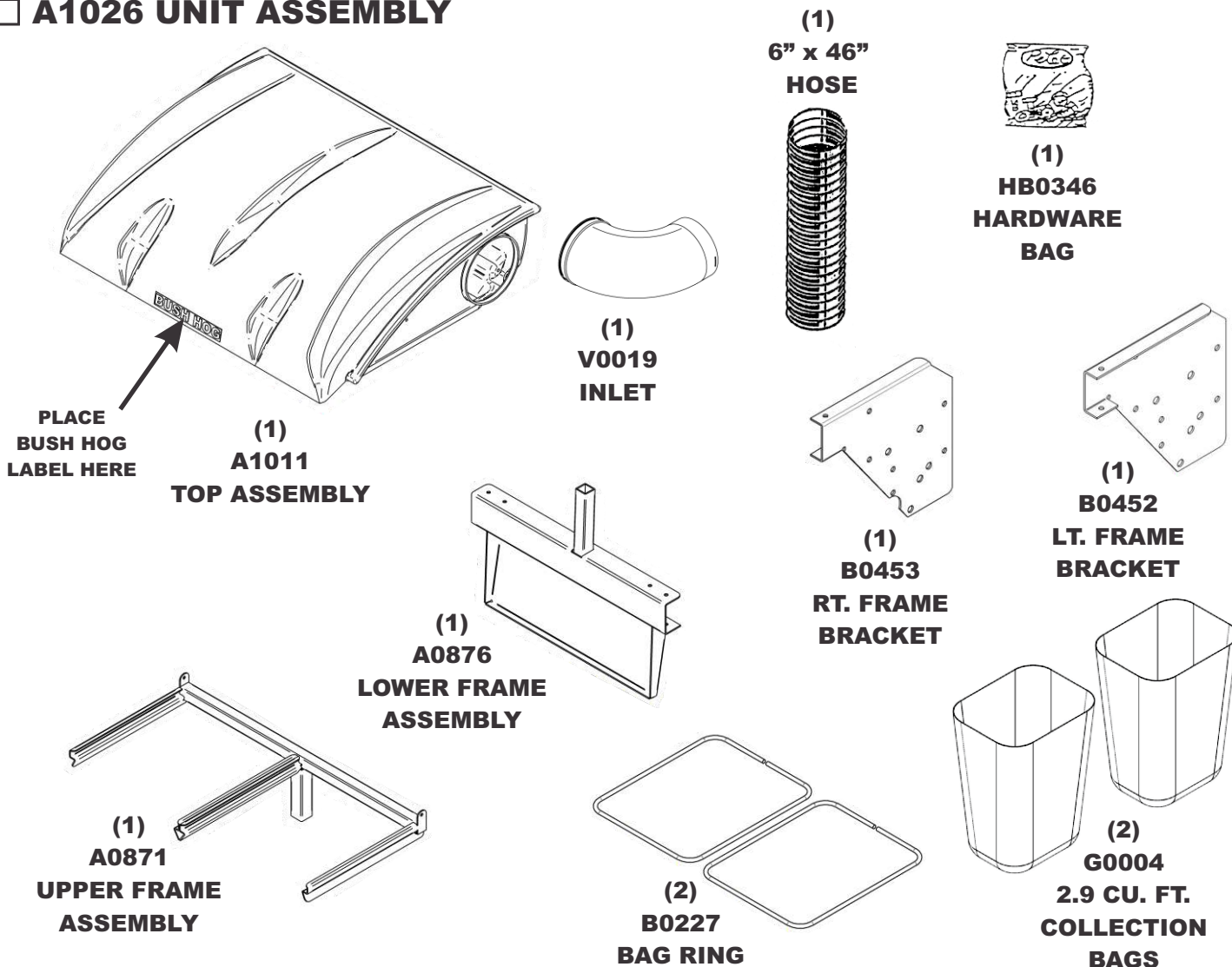

## A1027 BOOT AND WEIGHT KIT

