



PTO GRASS COLLECTION SYSTEM

2013 - 2015 MODEL YEAR

XSERIES

XDIABLO

BIG DOG
MOWERS

DIABLO

DIABLO MP

MODEL #: 52621201



OPERATOR'S MANUAL

ASSEMBLY • OPERATION • MAINTENANCE

PECO GRASS COLLECTION SYSTEM

TABLE OF CONTENTS

SECTION	PAGE	SECTION	PAGE
Safety	2	Exhaust Diverter Installation	17
Safety Alert Symbols	3	Boot Kit Installation	18
Warranty	4	Length of Hose Adjustment	19
I INTRODUCTION AND DESCRIPTION	5	Upper Hose Installation	19
Introduction	5	Lower Hose To Blower Cone Installation	19
Description	5	Lower Hose To Boot Installation	19
II INSTALLATION FOR USE	6	Impeller Blade Removal/Replacement	20
Preparation Of Mower	6	Weight Kit Installation	21
Left and Right Frame Bracket Installation	7	Exploded Drawing Views and Parts Lists	22-26
Rear Frame Bracket Installation	8	III OPERATING INSTRUCTIONS	27
Muffler Guard Installation	8	General Safety	27
Right and Left PTO Mount Plate Installation	9	Operation & Tips On Mowing	27
PTO Assembly Installation	10	Disengagement Of The Blower	27
Belt Installation and Adjustment	11	Unloading The Collection System	27
Cam Assembly Adjustment	12	IV MAINTENANCE	27
Blower Cone Installation	12	Maintenance Checklist	27-28
Main Frame Leg Installation	13	Lubrication	28
Main Frame Assembly Installation	13	V PARTS AND SERVICE	28
Lift Handle Installation	14	Parts And Service Information	28
Aluminum Grass Container Installation	15	Safety Decals	29
Dump Mechanism Adjustment	15	Torque Specifications	30
Aluminum Grass Container Exploded View	16		

Safety

1. Read the operator's manual carefully and familiarize yourself with the proper use of your attachment. Do not allow anyone who is not acquainted with the Safety Instructions to use your attachment.
2. Know the controls and how to stop quickly. **READ THE OPERATOR'S MANUAL!**
3. Do not allow children to operate the vehicle. Do not allow adults to operate it without proper instruction.
4. Be especially watchful of children and pets darting into the area while operating.
5. Keep your eyes and mind on your unit while mowing or operating your attachment. Don't let others distract you.
6. Do not attempt to operate your unit or mower when not in the driver's seat.
7. Always stop unit when emptying the container.
8. Stop unit, shut off deck attachment, set parking brake, shut off mower engine and remove spark plug wire before removing clogs, removing or replacing hose, boot, blower cone, or performing any maintenance.
9. Mow across the face of slopes (not steeper than 10 degrees); never up and down the face.
10. It is recommended that the container be kept only half full when negotiating any slopes. Start mowing on slopes when the container is empty.
11. Inspect your lawn and remove any foreign objects before mowing. Never deliberately run the mower across any foreign object.
12. Wear ear protection if the noise level is offensive.
13. Wear eye protection to prevent debris from damaging your eyes.

SAFETY

WARNING! NEVER operate the mower unless the discharge guard and either the deflector assembly or the vacuum collector adapter are fastened securely in place.

WARNING! Do not work around the mower deck boot or the blower area until you are certain that the mower blades and the blower impeller have stopped rotating.

WARNING! To avoid serious injury, perform maintenance on the vacuum collector; **ONLY AFTER STOPPING THE MOWER'S ENGINE AND WAITING FOR ALL MOVING PARTS TO COME TO A COMPLETE STOP.** Set the parking brake. Always remove the ignition key before beginning maintenance.

WARNING! For your own personal safety, **ALWAYS** mow **ACROSS** the face of slopes and **NEVER UP and DOWN** the face. **NEVER** attempt to mow excessively steep slopes, and use caution when turning on any slope.

Safety Alert Symbol



This Safety Alert Symbol means: **“ATTENTION! BECOME ALERT! YOUR SAFETY IS INVOLVED!”**

This symbol is used to call attention to safety precautions that should be followed by the operator to avoid accidents. When you see this symbol, carefully read the message that follows and heed its advice. Failure to comply with safety precautions could result in death or serious bodily injury.

Safety Signs

The signal words **DANGER**, **WARNING**, and **CAUTION** are used on the equipment safety signs. These words are intended to alert the viewer to the existence and the degree of hazard seriousness.



White letters on **RED**

This signal word indicates a potentially hazardous situation which, if not avoided, will result in death or serious injury.



Black letters on **ORANGE**

This signal word indicates a potentially hazardous situation which, if not avoided, could result in death or serious injury.

It may also be used to alert against unsafe practices.



Black letters on **YELLOW**

This signal word indicates a potentially hazardous situation exist which, if not avoided, will result in minor or moderate injury.

It may also be used to alert against unsafe practices.

PECO LIMITED WARRANTY FOR NEW PRODUCTS

A. WHAT IS UNDER WARRANTY?

PECO extends the following warranties to the original purchaser of each new PECO consumer product subject to the following limitations.

1. PRODUCT WARRANTY: Any part of any consumer product, which is defective in material or workmanship as delivered to the purchaser will be repaired or replaced, as PECO elects, without charge for parts or labor, if the defect appears within 12 months from the date of delivery of the product to the original purchaser.

ALL DEFECTIVE PARTS MUST BE RETURNED TO PECO FOR INSPECTION TO DETERMINE VALIDITY OF WARRANTY CLAIMS. Freight and mailing will be borne by the customer.

2. PARTS REPLACED DURING WARRANTY: Any new PECO part which is furnished in performance of this warranty and is defective in material or workmanship as delivered to the purchaser will be repaired or replaced, as PECO elects, without charge if the defect appears within 90 days from the date of installation of such part or before the expiration of the original warranty period, whichever is later.

B. SECURING WARRANTY ADJUSTMENTS.

Call PECO for Return Authorization. Damaged or broken parts other than engines or batteries, must be returned to New PECO, Inc. 100 Airport Road, Arden, NC 28704 before any warranty adjustment can be authorized. At the time of requesting warranty adjustment, the purchaser must present evidence of the date of delivery of the product. The purchaser shall pay any charge for the product to and from Arden, NC.

C. ITEMS NOT COVERED BY PECO WARRANTY.

Engines and batteries attached to PECO products are covered under a separate warranty by the respective manufacturer.

D. UNAPPROVED ALTERATION OR MODIFICATION.

All obligations of New PECO, Inc. under this warranty shall be terminated if products are altered or modified in ways not approved by New PECO, Inc.

E. ACCIDENTS AND NORMAL MAINTENANCE.

The warranty covers only defective material and workmanship. It does not cover depreciation or damage caused by normal wear, accident, improper use or abuse of products. The cost of normal maintenance and normal replacement of service items such as belts, cutting blades, hoses, etc., which are not defective shall be paid for by the purchaser.

F. NO REPRESENTATIONS ADDITIONAL WARRANTIES, DISCLAIMER.

Neither New PECO, Inc. nor any company affiliated with it makes any warranties, representations or promises as to the quality of performance of its products other than those set forth herein. Except as described above, New PECO, Inc. makes no other warranties **AND SPECIFICALLY DISCLAIMS ANY AND ALL IMPLIED WARRANTIES OF FITNESS AND MERCHANTABILITY.**

G. ANY MACHINE USED FOR RENTAL PURPOSES ARE GUARANTEED FOR 45 DAYS FROM DATE OF ORIGINAL SALE ONLY.

H. REMEDIED EXCLUSIVE.

The only remedies the purchaser has in connection with the breach or performance of any warranty on New PECO, Inc. consumer products are set forth above. In no event will PECO be liable for special incidental or consequential damages.

1. NO SERVICE CENTER WARRANTY.

The selling Service Center makes no warranty on his own on any item warranted by New PECO, Inc. unless he delivers to purchaser a separate written warranty certificate specifically warranting the item. The dealer has no authority to make any representation or promise on behalf of PECO or to modify the terms of this warranty in any way.

Section I - INTRODUCTION AND DESCRIPTION

Introduction

Your collection system has been designed to give you a low maintenance, simple, and effective way to collect the grass clippings from your mower. This manual is provided to give you the necessary instructions to properly mount and operate the collection system on your mower. Please read this manual thoroughly. Understand what each control is for and how to use it. Observe all safety decal precautions on the machine and noted throughout the manual.

NOTE: All references made to right, left, front, rear, top or bottom are as viewed from the normal operator's position on the mower.

Description

The grass collection system is designed for turf maintenance where there is a need to collect the grass clippings as the mower cuts the turf. It is also used for picking up leaves and in pre-season and post-season clean-up. The blower, mounted on the right side of the unit, uses a belt and gearbox system from the engine PTO shaft. Drive train protection comes through belt slippage. The blower draws grass clippings from the discharge area of the cutter deck back to the 12 cubic foot aluminum box at the rear portion of the mower frame. The operator can engage the blower with a push of the over-center linkage on the right side of the unit, or starting the external engine. Once the collection box is full with clippings, it can be released to make for easy dumping.

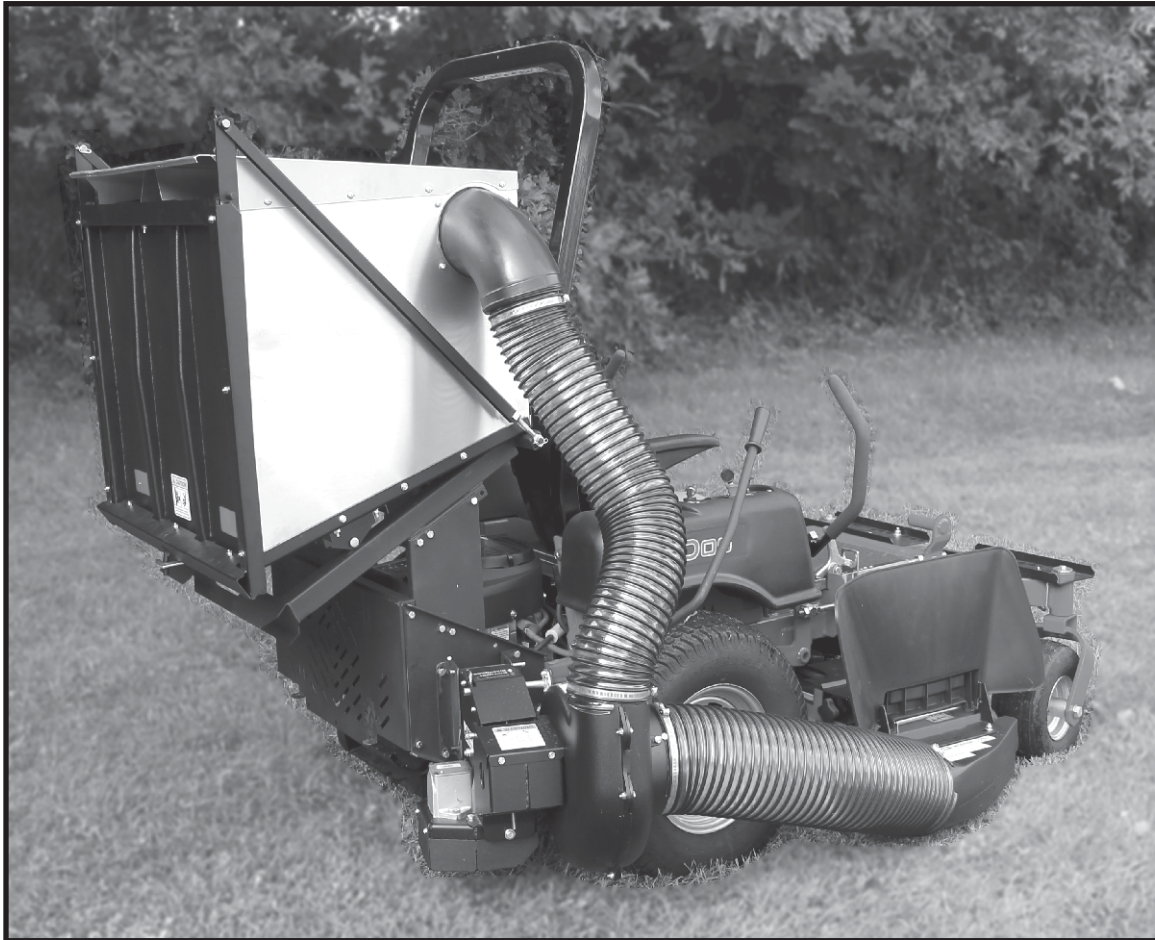

Section II - INSTALLATION FOR USE

Preparation Of Mower

NOTE: The mower deck PTO belt must be removed from the electric clutch before continuing with the installation. Refer to your mower owner's manual for instructions on PTO belt removal.

From the underside of the engine, disconnect the wiring harness attached to the electric clutch. Remove the bolt and electric clutch from the mower. Refer to Figure A.

Figure A

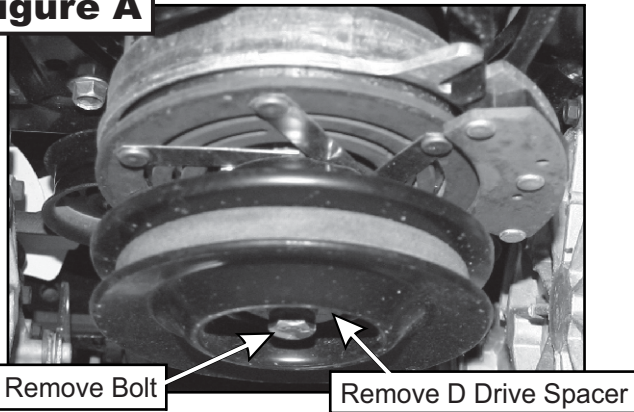

Remove the D-drive spacer using an arbor press or equivalent. On removal, adjacent bearing OUTER race must be supported or bearing damage may occur. Refer to Figure B.

Figure B

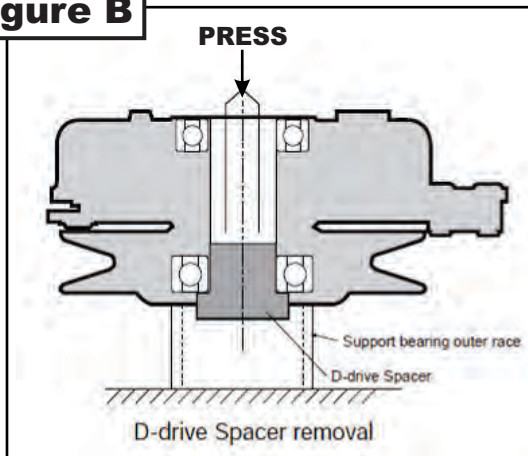
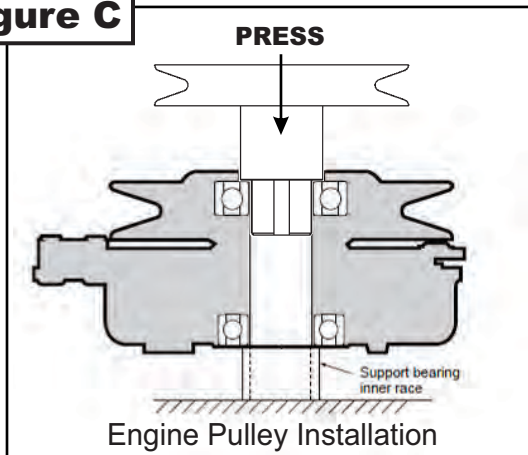

Figure C



The engine pulley assembly must be installed using an arbor press or equivalent. During installation, opposite bearing inner race must be supported or bearing damage may occur. Refer to Figure C.

Upon pressing the engine pulley to the clutch, replace the completed assembly to the mower's engine shaft to fasten.

Figure D

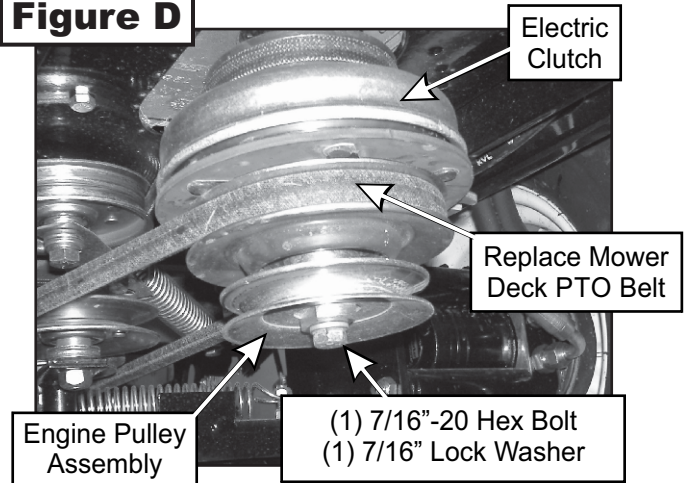

26 HP Briggs & Stratton

Fasten the engine pulley assembly stamped with number 23 P#(A1175) to the electric clutch using (1) 7/16"-20 x 3-1/4" HHCS P#(K0351) and (1) 7/16" helical spring lock washer P#(K0140). Torque the bolt to 55ft./lbs. Refer to Figure D for reference.

Kawasaki FX850

Fasten the engine pulley assembly stamped with number 20 P#(A1798) to the electric clutch using (1) 7/16"-20 x 4-1/2" HHCS P#(K0427) and (1) 7/16" helical spring lock washer P#(K0140). Torque the bolt to 55ft./lbs. Refer to Figure D for reference.

Kawasaki FX1000V

Fasten the engine pulley assembly stamped with number 20 P#(A1798) to the electric clutch using (1) 7/16"-20 x 4" HHCS P#(K0359) and (1) 7/16" helical spring lock washer P#(K0104). Torque the bolt to 55ft./lbs. Refer to Figure D for reference.

NOTE: Replace the mower deck PTO belt removed at the beginning of this section.

Figure A

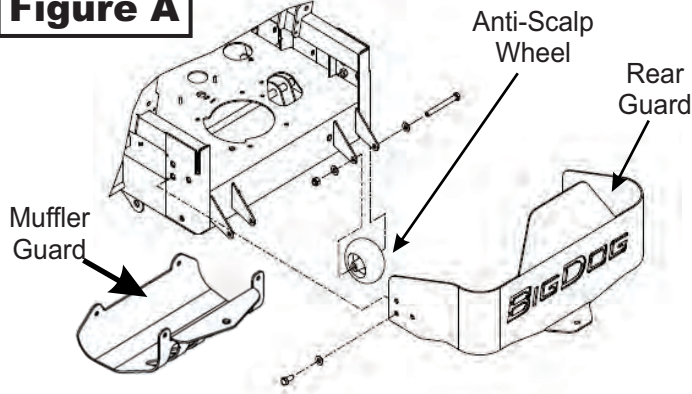

Remove the rear guard and hardware from the mower frame. Remove the rear right anti-scalp wheel and hardware. Refer to Figure A.

NOTE: X-Diablo, Diablo and DiabloMP series will need to have the muffler guard removed and replaced with muffler guard P#(B0831) in a later step.

Note: On Diablo and DiabloMP

Exhaust pipe must be cut off 1.5" from original length. 90 degree diverter must be attached and secured with clamp. See Figure B

Figure B

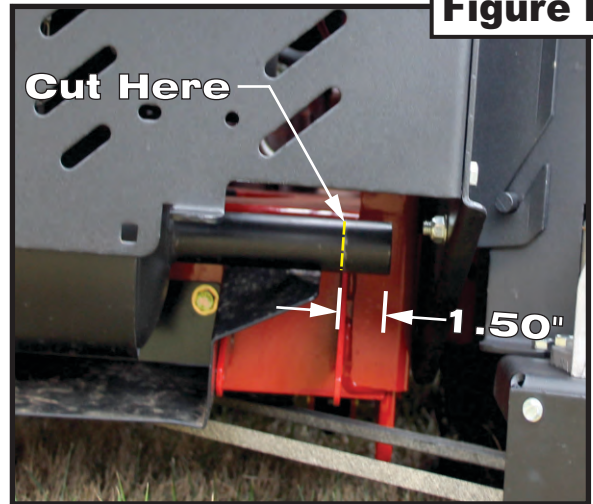

Left and Right Frame Bracket Installation

Secure the left frame bracket P#(B0826) and right frame bracket P#(B0825) to the rear frame of the mower using the mounting holes where the rear guard was removed.

X-Series

Secure the left and right frame brackets and (2) frame mount spacers P#(B0840) to the rear frame of the mower using (3) 1/2"-13 x 1-1/4" HHCS P#(K1232), (3) 1/2" flat washers P#(K0055) and (3) 1/2"-13 nylon flange locknuts P#(K2012) PER BRACKET. The frame mount spacers will mount to the inside, between the frame brackets and mower frame. Refer to Figure C and D.

Figure C

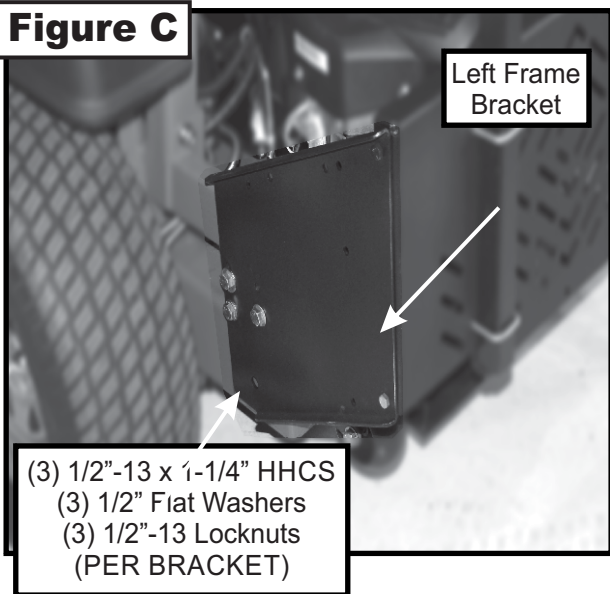
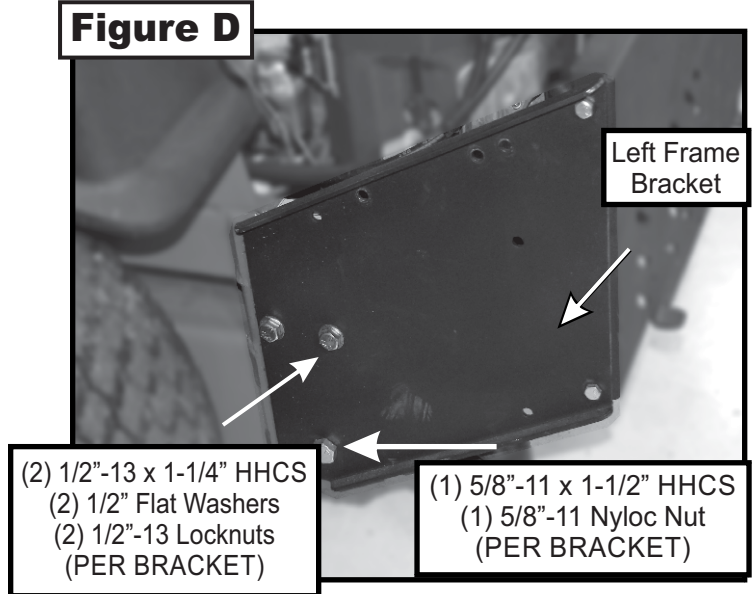

Figure D



X-Diablo, Diablo and DiabloMP Series

Secure the left and right frame brackets to the rear frame of the mower using (2) 1/2"-13 x 1-1/4" HHCS P#(K1232), (2) 1/2" flat washers P#(K0055) and (2) 1/2"-13 nylon flange locknuts P#(K2012) PER BRACKET. Secure the bottom mounting holes with (1) 5/8"-11 x 1-1/2" HHCS P#(K1251) and (1) 5/8"-11 nyloc nut P#(K1316). Refer to Figure D.

Rear Frame Bracket Installation

Secure the rear frame bracket P#(B0827) to the left and right frame bracket using (2) 3/8"-16 x 1" HHCS P#(K1191) and (2) 3/8"-16 nylon flange locknuts P#(K2038) PER BRACKET. Refer to Figure A.

Figure A

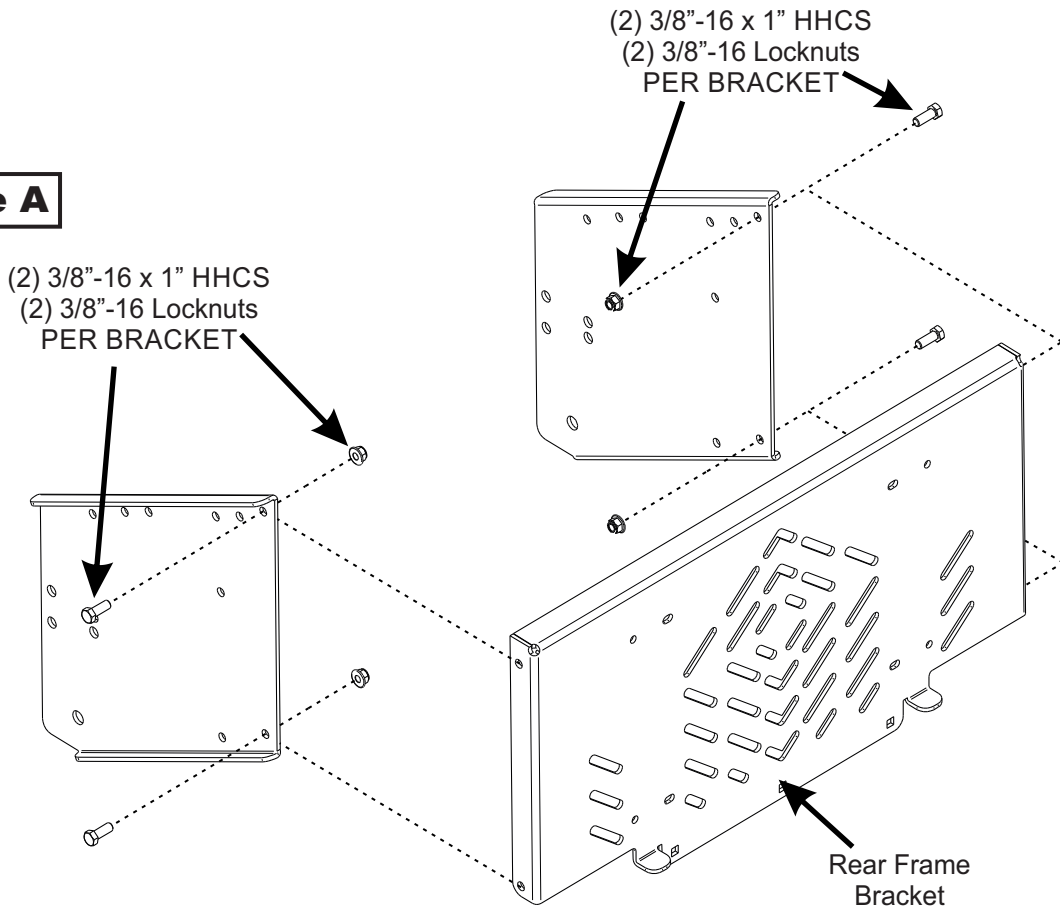

Muffler Guard Installation

X-Diablo, Diablo & DiabloMP Series

Secure the muffler guard P#(B0831) to the rear frame bracket and rear frame of the mower using (4) 3/8"-16 x 1" carriage bolts P#(K1182) and (4) 3/8"-16 nylon flange locknuts P#(K2038) as shown in Figure B.

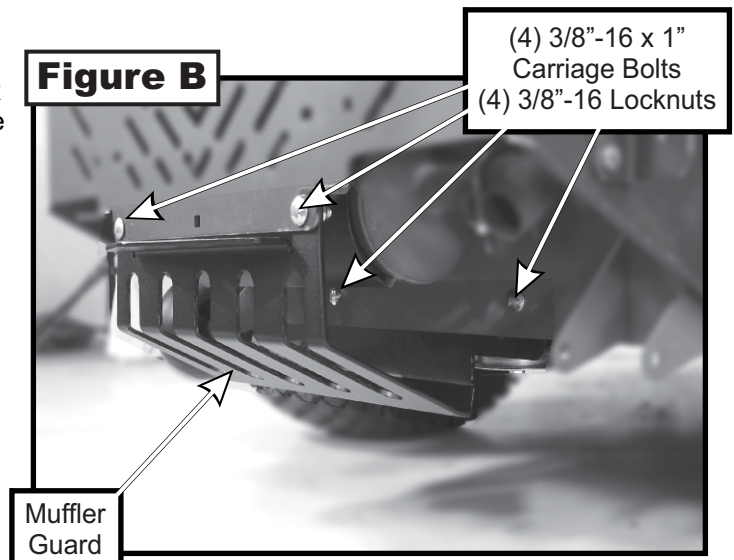

Right and Left PTO Mount Plate Installation

Secure the left PTO mount plate P#(B0829) to the right frame bracket using (2) 3/8"-16 x 1" HHCS P#(K1191) and (2) 3/8"-16 nylon flange locknuts P#(K2038). Refer to Figure A and B for reference.

Secure the right PTO mount plate P#(B0828) to the right frame bracket using (1) 3/8"-16 x 1" HHCS P#(K1191) and (1) 3/8"-16 nylon flange locknut P#(K2038). Secure the lower mounting hole with (1) 1/2"-13 x 1-1/4" HHCS P#K1232 and (1) 1/2"-13 nylon flange locknut P#(K2012). Refer to Figures A and B for mounting holes locations specific to your series.

Figure A

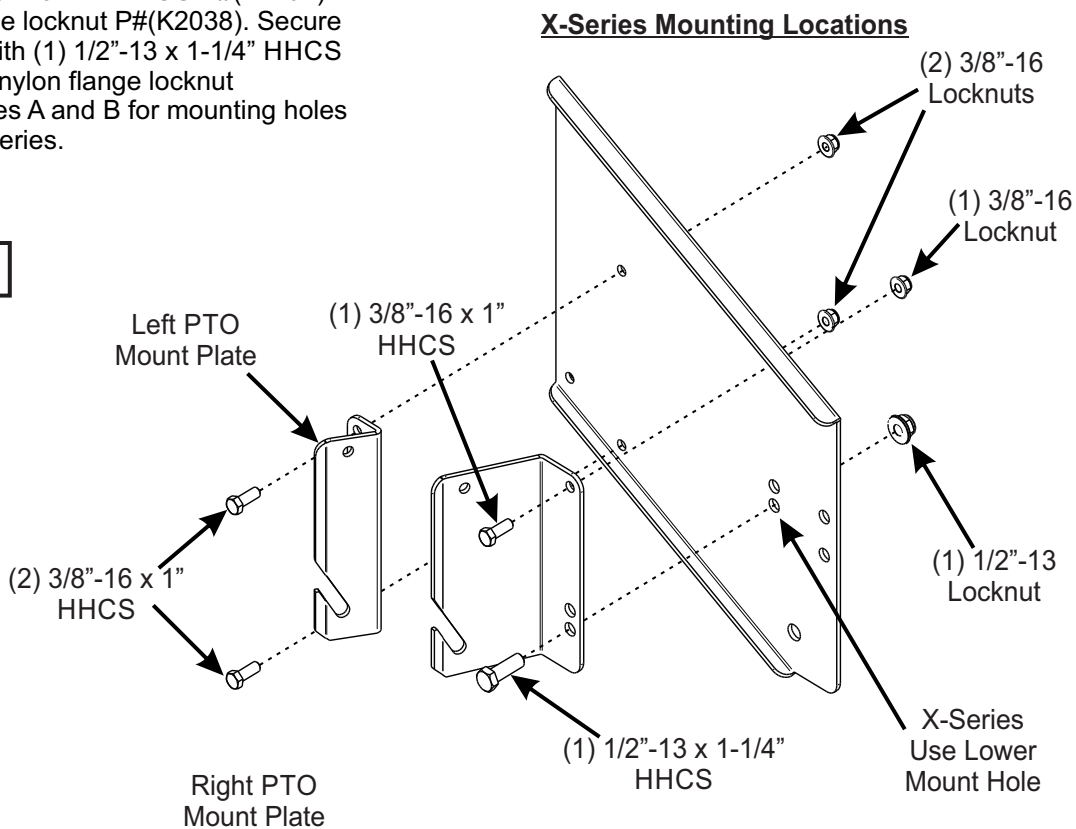
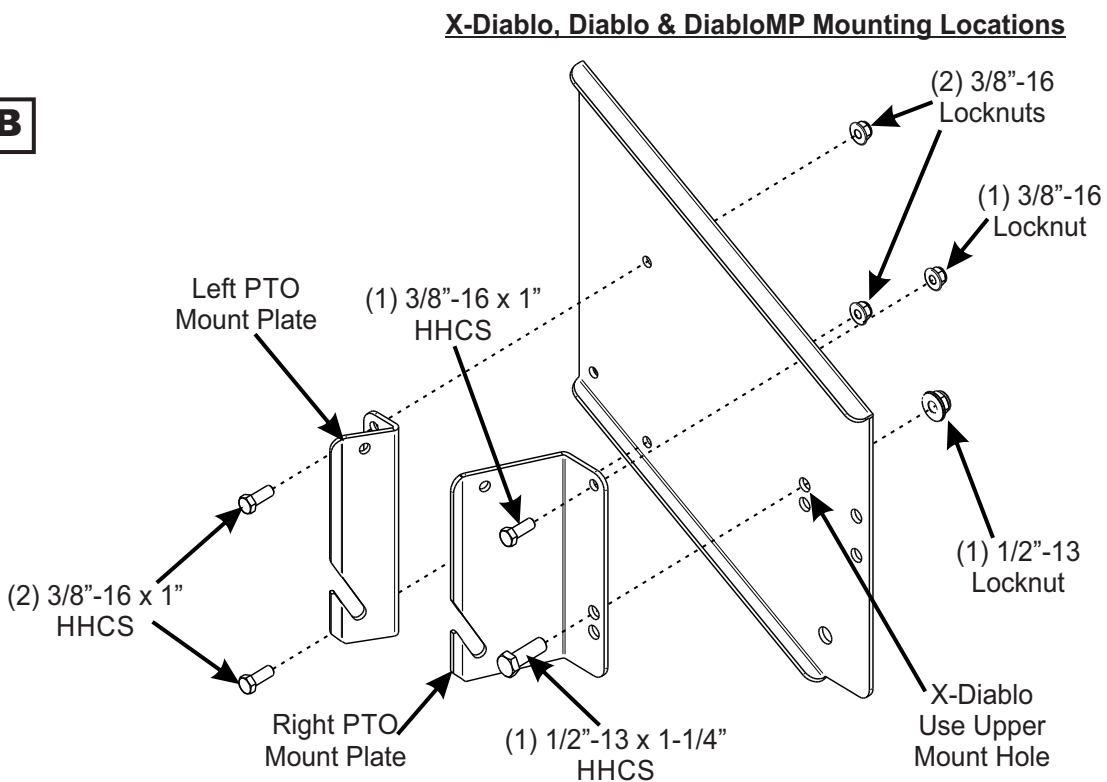

Figure B



PTO Assembly Installation

Insert the PTO assembly P#(A0623) into the slots on the PTO mount plate assembly. Secure the PTO assembly with (1) mount pin P#(B0274) and (1) hair pin clip P#(K0086).

Remove the engine pulley guard and hardware in preparation for the belt installation. Refer to Figure A.

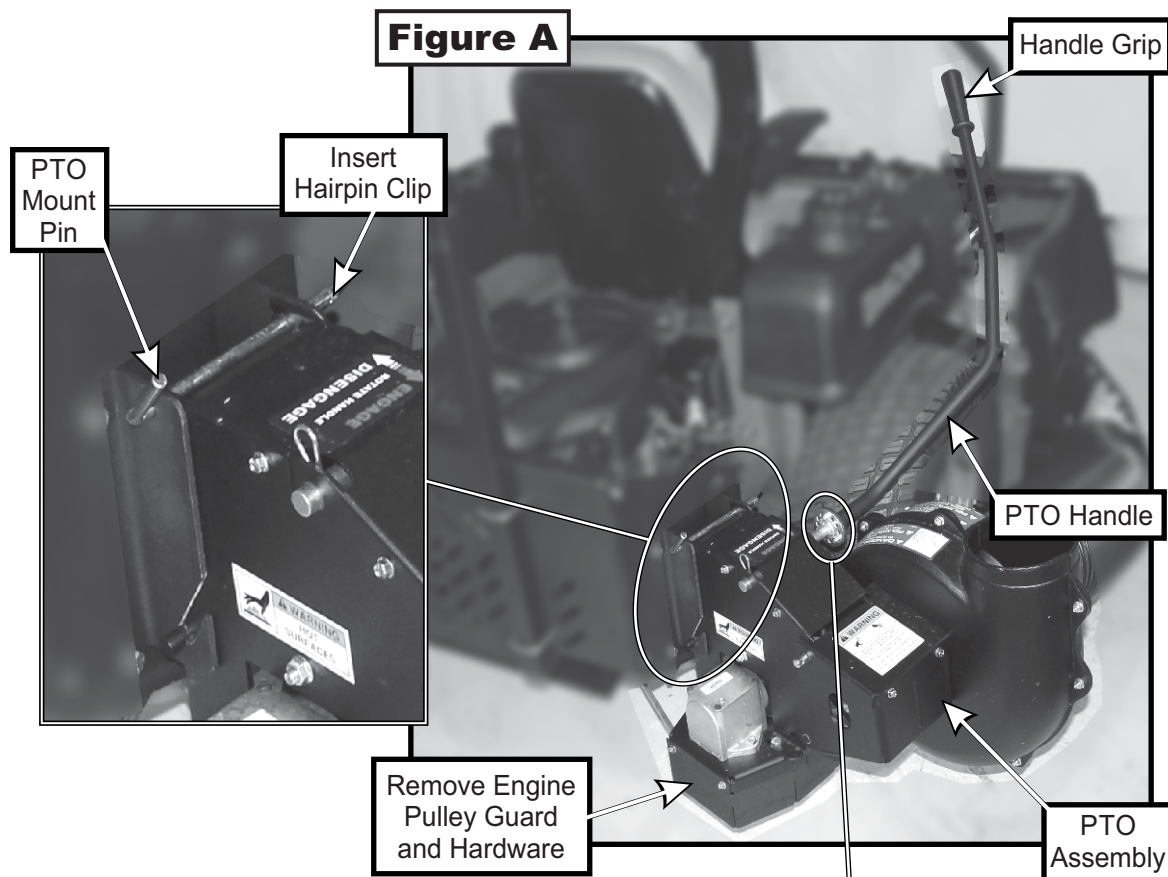

Attach the PTO handle P#(A0626) to the PTO assembly using (3) 1/4"-20 x 3/4" HHCS P#(K1222) and (3) 1/4"-20 nylon flange locknuts P#(K2014). Attach the handle grip P#(J0522) to the PTO handle. Refer to Figure A and B.

NOTE: The PTO Handle can be adjusted, after performing installation, to achieve proper belt adjustment. To adjust the handle, remove (3) 1/4"-20 x 3/4" HHCS P#(K1222) and (3) 1/4"-20 nylon flange locknuts P#(K2014), rotate handle until positioned in the desired location (while aligning holes) and reattach. The bolts should be kept approximately 120 degrees apart to ensure proper fastening.

Figure B

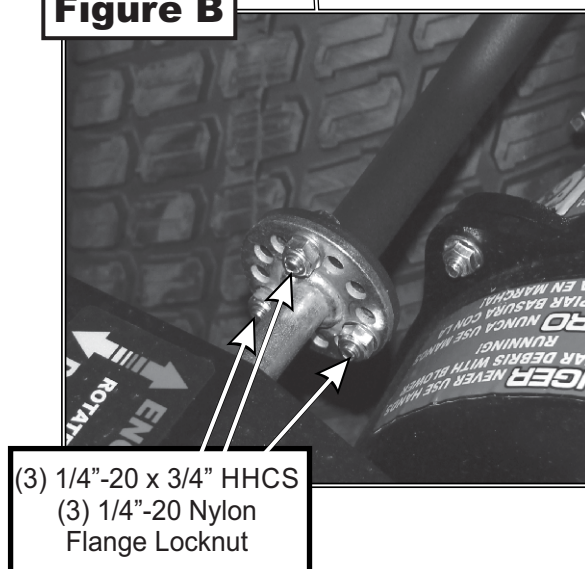

Belt Installation and Adjustment

Loosen the (4) bolts P#(K1191), (2) on each side, that secure the gear box assembly to the PTO assembly P#(A1803) (Figures A and B).

Figure A

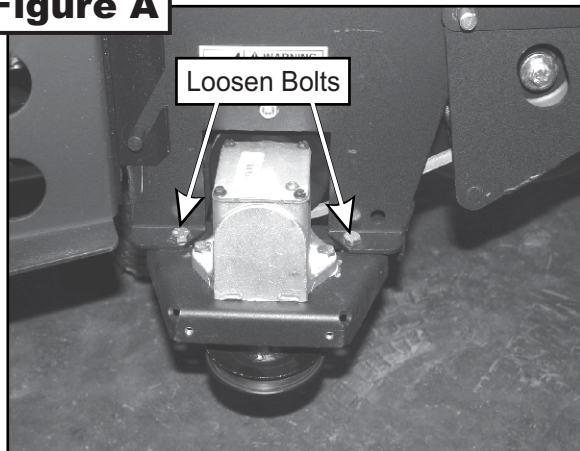
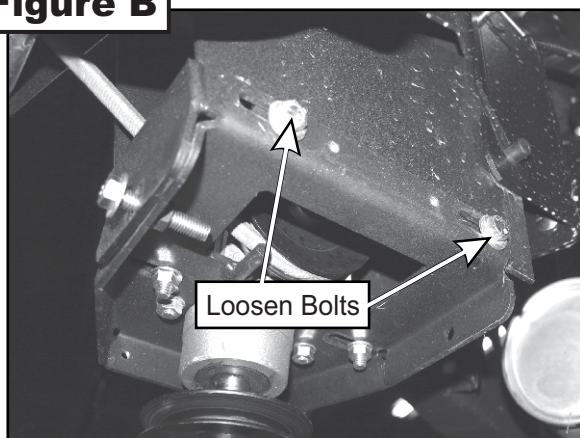
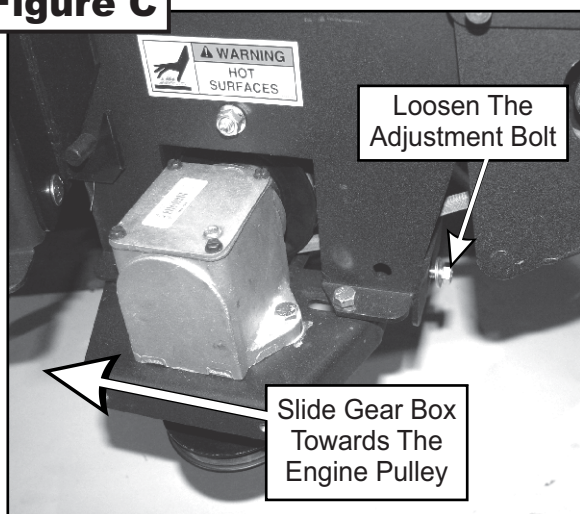

Figure B



Loosen the adjustment bolt P#(K0348) until the gear box assembly is at its far left adjustment (the gear box is moved toward the mower's engine pulley). Refer to Figure C.

Figure C



Connect the kevlar cord belt A59K P#(M0254) from the engine pulley to the lower gear box pulley (Figure D).

Figure D

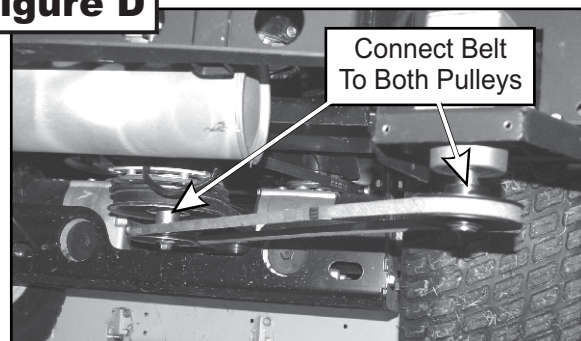

To tension the drive belt, turn the adjustment bolt clockwise (Figure E) until there is 1" of deflection, with 10-11 lbs. of pressure, at the center of the belt between the engine pulley and the gear box pulley.

Figure E

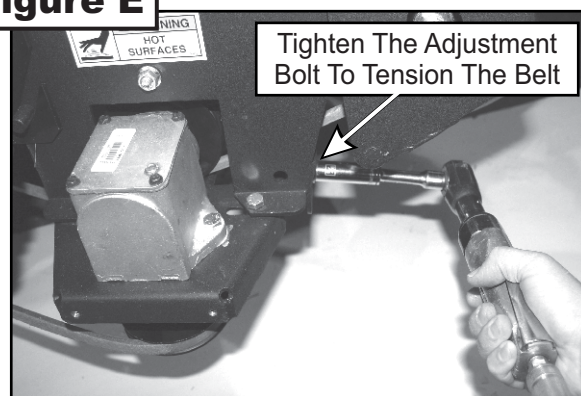

Once the correct tension of the belt is achieved, tighten the (4) bolts that secure the gear box assembly. Refer to Figures F and G. Replace the belt guard and hardware that was removed earlier.

Figure F

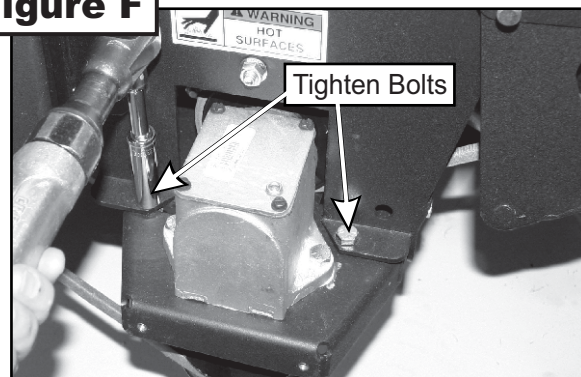
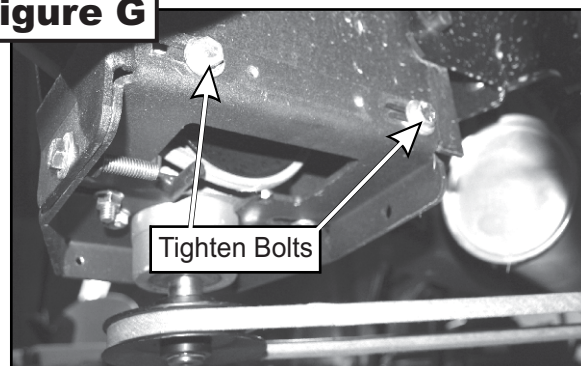

Figure G



Cam Assembly Adjustment

The cam assembly P#(A0422), which controls the blower belt tension, comes from the factory pre-adjusted. If the belt is too tight or becomes too loose, remove the hair pin clip P#(K0099) from the belt tension rod P#(K0326) and pull the "L" end of the rod out of its hole in the cam assembly. The tension rod may then be screwed out to tighten the belt or screwed in to loosen the belt. Replace the "L" end into the top hole in the cam and replace the hair pin clip. Adjust the cam stop bolt P#(K1159) to allow the cam to rotate slightly over center when the blower is disengaged (Figure A).

Figure A

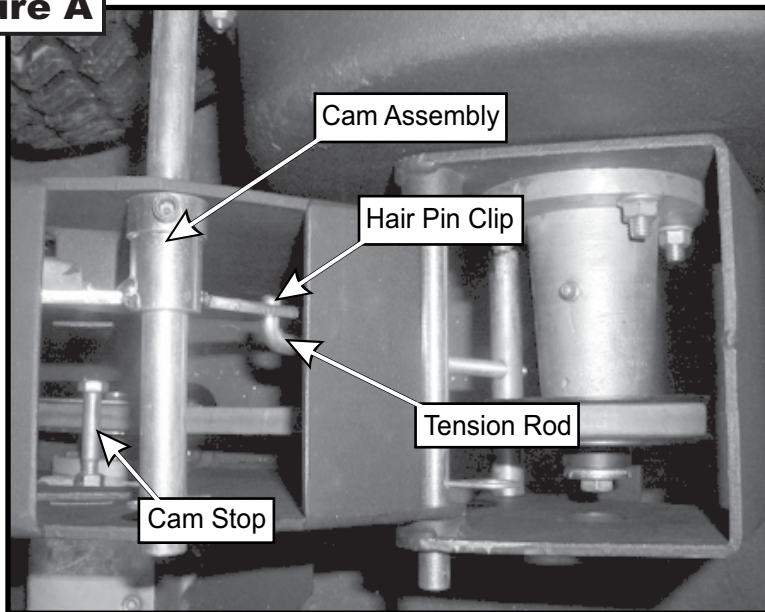

Blower Cone Installation

Thread (1) 5/16"-18 jam nut P#(K0120) onto each end of (2) 5/16"-18 x 2-1/2" HHCS P#(K0125). Now partially thread the bolts into each of the two tabs located on the blower housing. Place blower cone P#(E6009) so the two tabs line up with the bolts then tighten completely. See Figure B.

Figure B

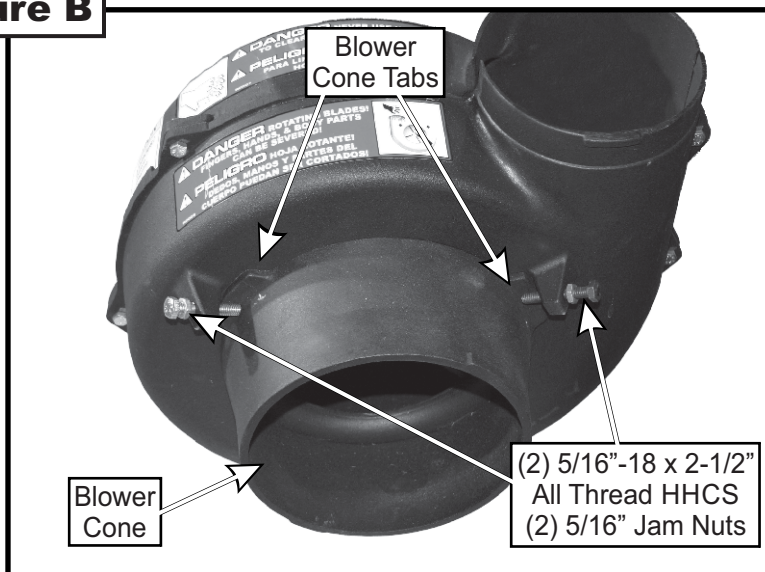

Main Frame Leg Installation

Secure (1) main frame leg P#(B0830) to the left frame bracket and (1) main frame leg P#(B0830) to the right frame bracket using (2) 3/8"-16 x 1" HHCS P#(K1191) and (2) 3/8"-16 nylon flange locknuts P#(K2038) PER FRAME LEG. Refer to Figure A for **X-Diablo, Diablo & Diablo-MP** Series mounting locations. Refer to Figure B for **X-Series** mounting locations.

Main Frame Assembly Installation

Lift the main frame assembly P#(A0995) into position as shown in Figure A. Secure the main frame assembly to the main frame legs using (4) 3/8"-16 x 1" HHCS P#(K1191) and (4) 3/8"-16 nylon flange locknuts P#(K2038).

Figure A

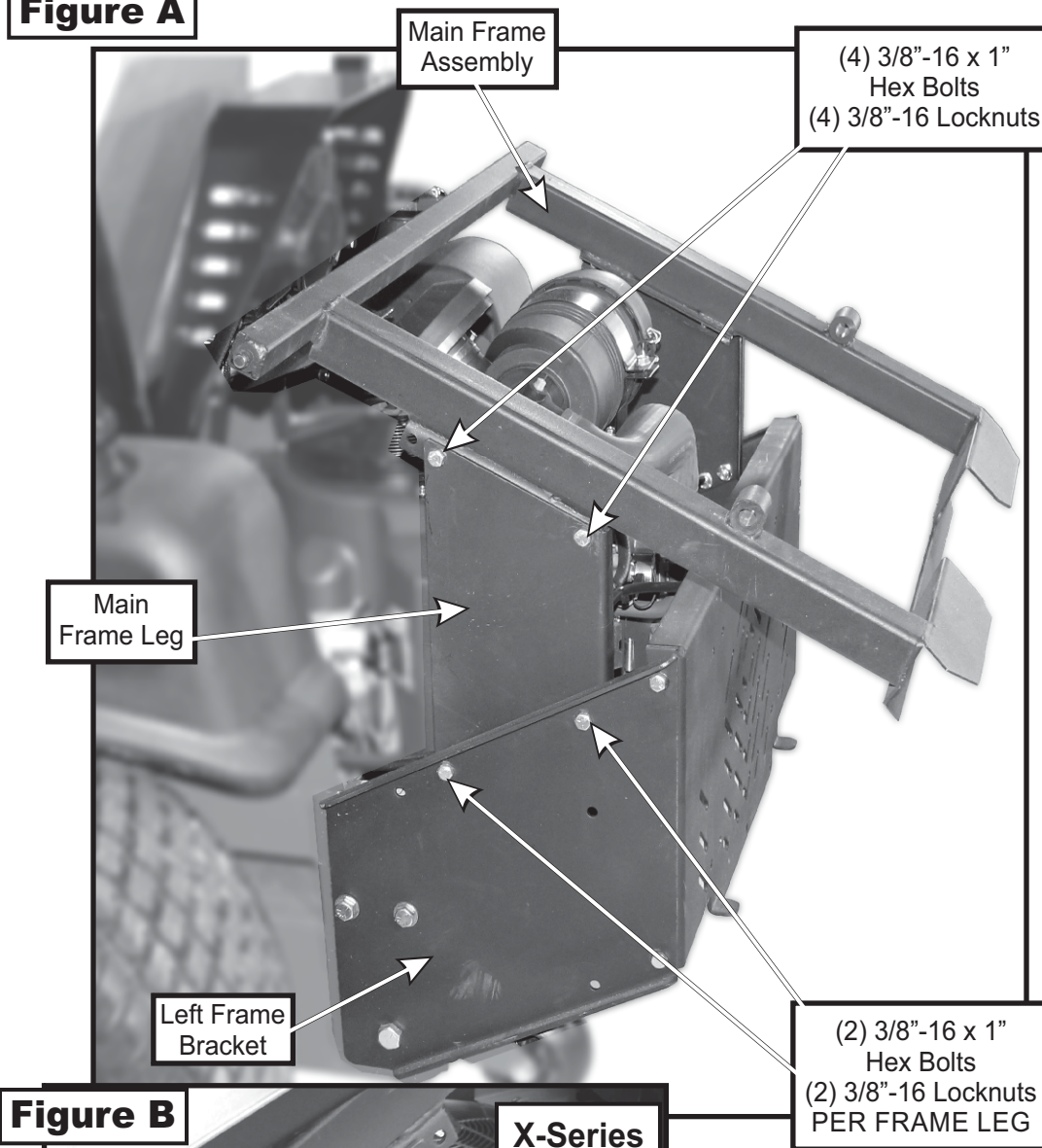
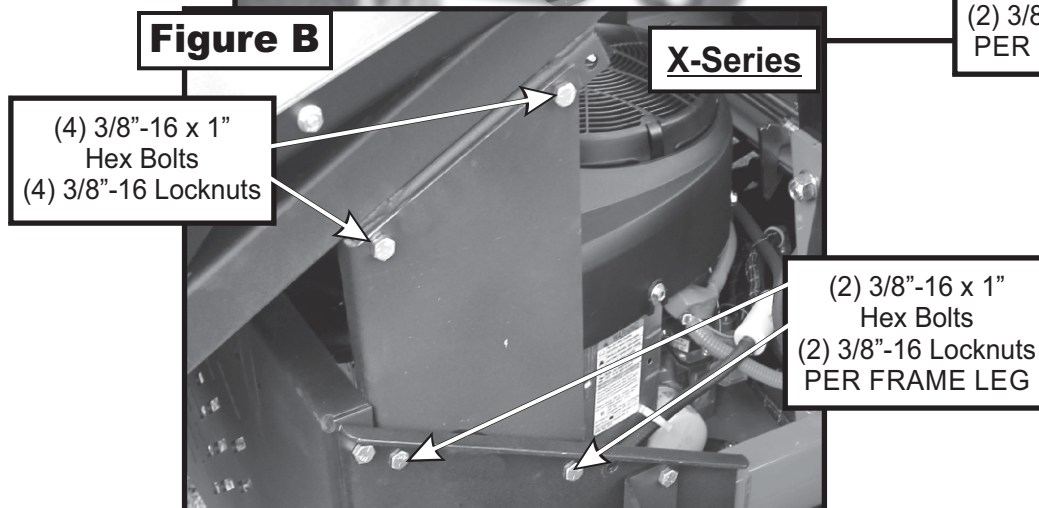
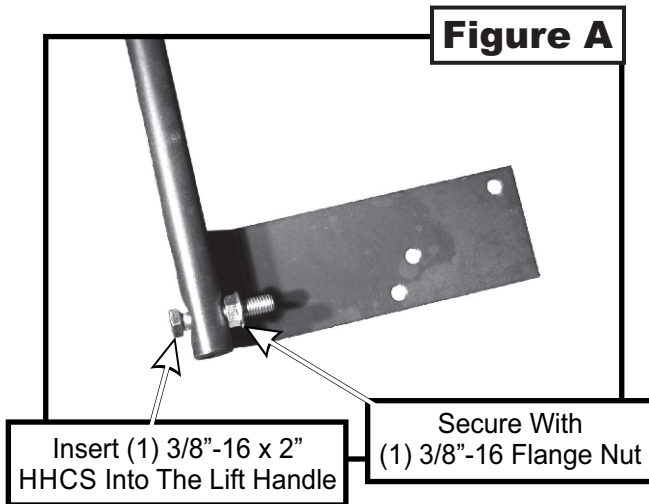

Figure B



Lift Handle Installation

NOTE: Before continuing the lift handle installation, have someone assist you in turning the grass container upside down. Insert (1) 3/8"-16 x 2" HHCS P#(K1208) into the lift handle P#(A0614), and secure with (1) 3/8"-16 flange nut P#(K1215). Thread the flange nut onto the bolt upside down, as shown in Figure A.



Slide the lift handle through the slot on the handle mount bracket. Insert the lift handle into the box frame as shown in Figure B, and secure using (1) 3/8"-16 flange nut P#(K1215) on the inside of the container as shown in Figure C.

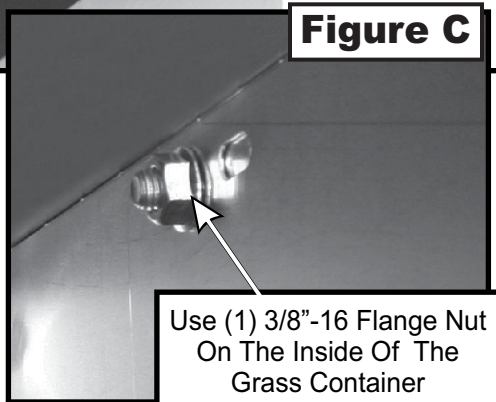
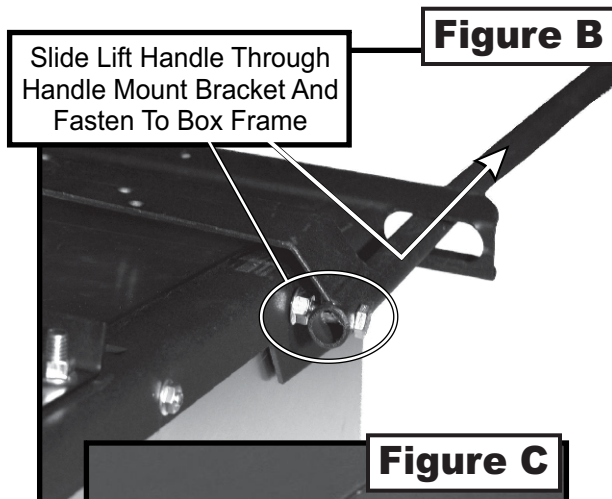

Fasten the ball joint P#(K1442) to the end of the latch rod P#(A0620). Tighten the ball joint to approximately half way down the threads on the latch rod. Attach the ball joint to the latch hook as shown in Figure D, using (1) 5/16"-24 hex nut P#(K1444) and (1) 5/16" lock washer P#(K0043).

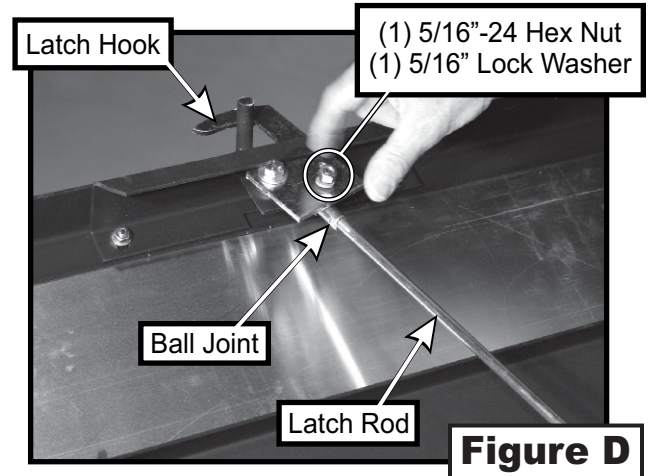

Attach the other end of the latch rod to the lift handle, as shown in Figure E. Attach on end of the spring P#(J0176) to the lift handle and the other end of the spring to the handle mount bracket as shown in Figure F. Adjust the ball joint up or down on the latch rod threads until the latch hook closes completely. After adjusting the latch hook, secure the latch rod to the lift handle using (1) cotter pin P#(K0094).

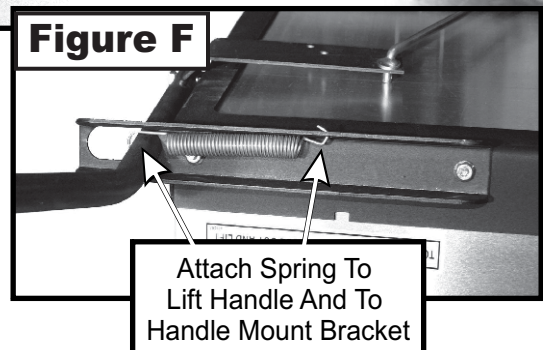
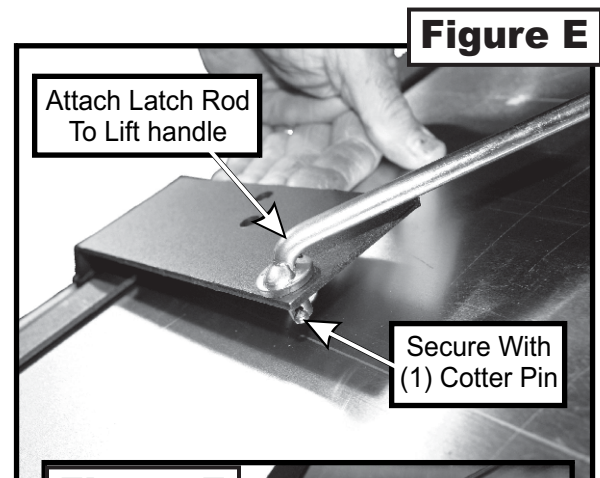

Aluminum Grass Container

Installation

NOTE: It is recommended that (3) people assist in mounting the container. With three people available, two can lower the container onto the frame while the third person inserts the pivot pins P#(K0172) through the holes. Insert the pins from the outside to the inside. Secure with (1) 5/8" washer P#(K0058) and (1) 5/32" x 2-5/8" hair pin clip P#(K0088) per pivot pin (Figure A). Reattach the bottom ends of the door opening linkages to the main frame by using (1) Rue-Ring cotter pin P#(K1437) per side. To test the functionality of the dump mechanism, pull the lift handle away from the unit, and lift upward. The door of the container should open and the box should pivot clockwise towards the ground.

Figure A

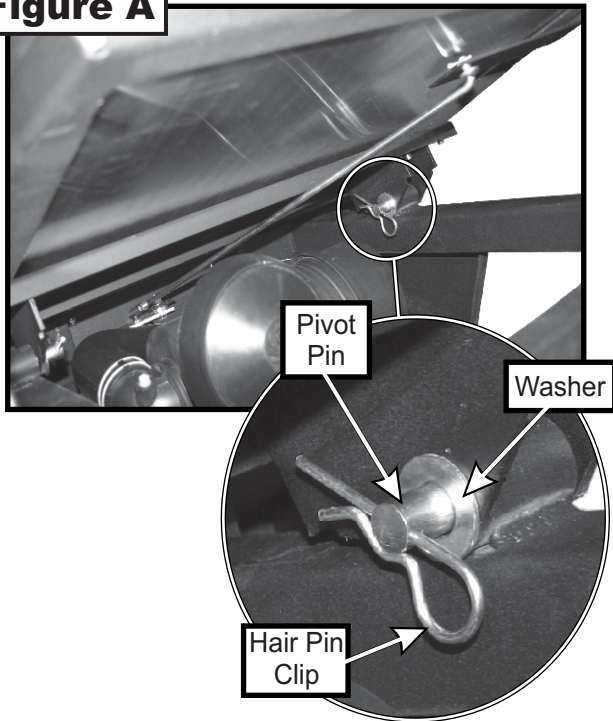

Dump Mechanism Adjustment

The linkage may be adjusted in two places, at the adjusting screw P#(K1435) and the latch assembly items. See page 16 for visual clarification. To change the door closure tightness, screw the adjusting screw (Figure B) in or out. To adjust the latch, change the length of the latch rod by screwing the latch adjusting ball joint in or out. The latch hook pivot should be in the middle of the slot in the latch hook pivot plate. Slide the pivot back or forth and then re-tighten.

Figure B

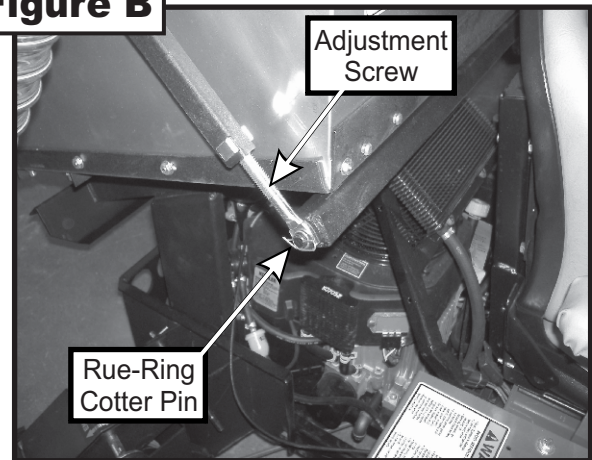

**ALUMINUM GRASS
CONTAINER
EXPLODED VIEW**

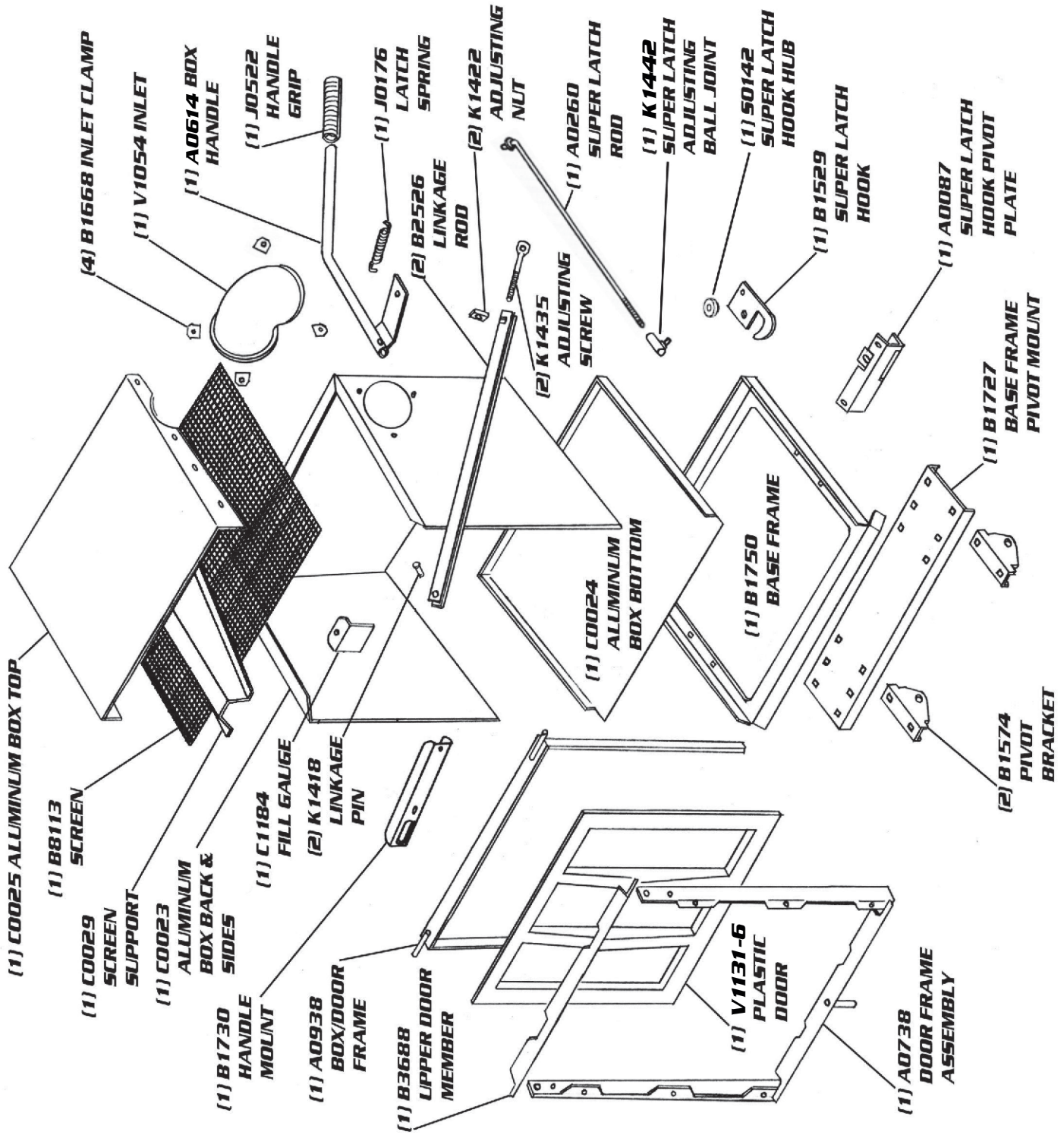

2-15 Exhaust Diverter Installation

NOTE: On certain engine models, it is necessary to install an exhaust diverter onto the muffler to prevent the engine exhaust from damaging the PTO assembly or the collection bags. Figure A shows an exhaust diverter P#(J0251) and exhaust clamp kit P#(X1046) installed on the Kawasaki FX850. **Any engine that exhaust to the right side or the rear, will require an exhaust diverter.** Slide the diverter onto the muffler exhaust tube and secure with (1) clamp kit. Position the diverter so that the heat is not directed towards the ground.

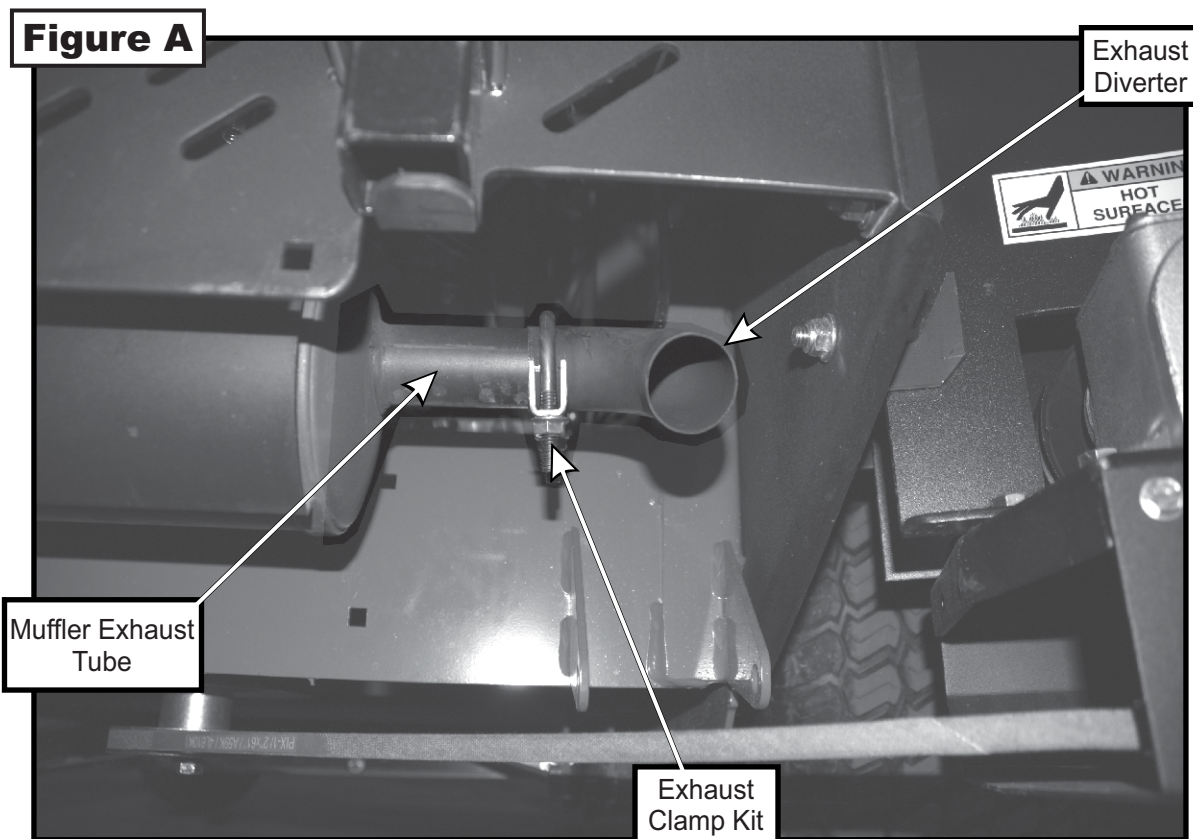

Boot Kit Installation

Position the boot plate P#(B0832) onto the top of the aluminum boot P#(E0025) as shown in Figure A. Secure the boot plate to the boot using (3) 3/8"-16 x 1" carriage bolts P#(K1182) and (3) 3/8"-16 nylon flange locknuts P#(K2038). Insert the bolts from the inside of the boot so that the lock nuts are on top of the boot plate. This will prevent grass clipping from collecting on the bolt threads. Leave the hardware slightly loose until the boot kit installation is complete.

The boot kit is designed to work on the 52" and 60" decks. After attaching the boot plate to the boot, lift the grass deflector and hang the boot plate on the discharge chute of the mower deck. The boot plate is slotted for positioning once attached to the mower deck. Slide the boot forwards or backwards until you eliminate any gaps between the discharge chute and boot. You want the boot to fit as closely as possible to the mower deck to prevent grass blow-out. Once the boot has been positioned properly, tighten the boot kit hardware. Refer to Figures A, B & C for reference.

Figure A

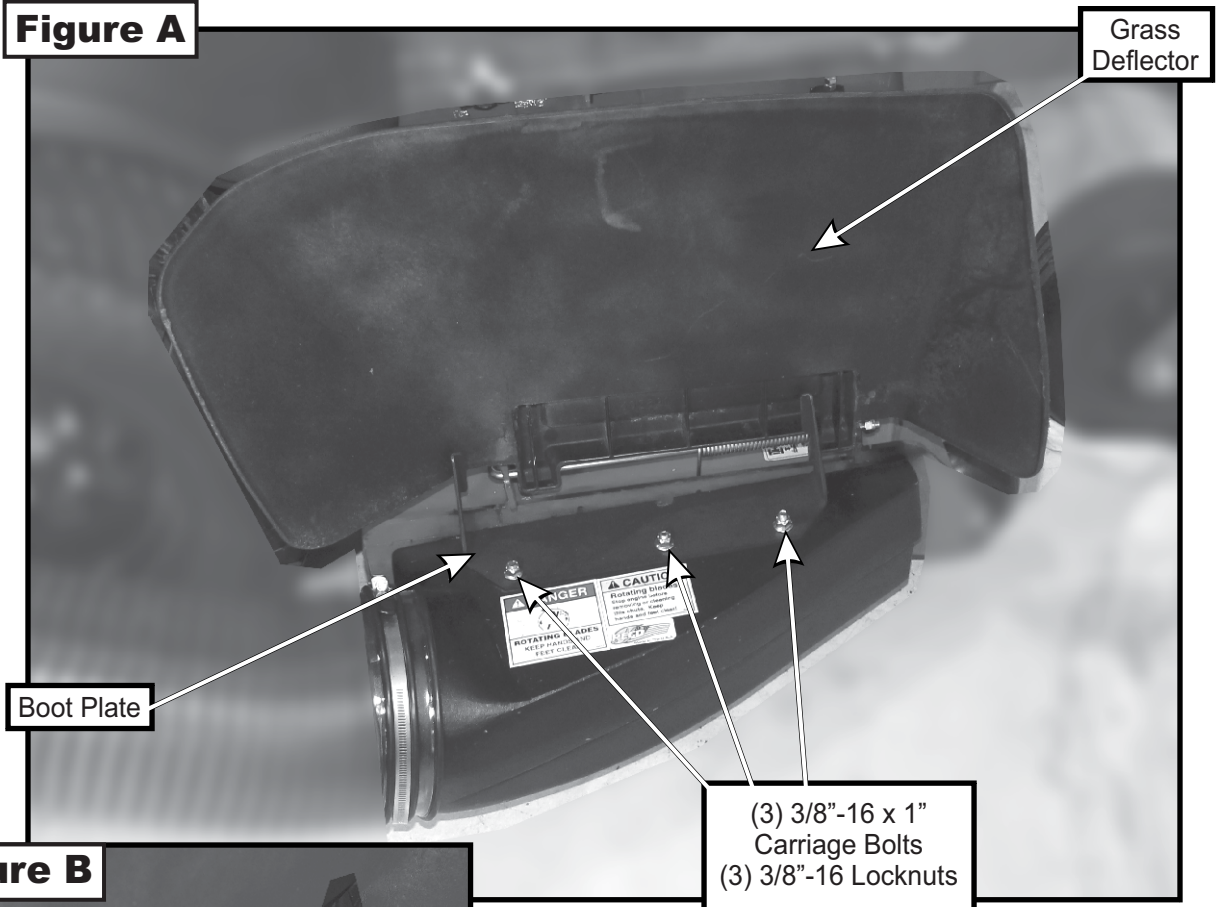

Figure B

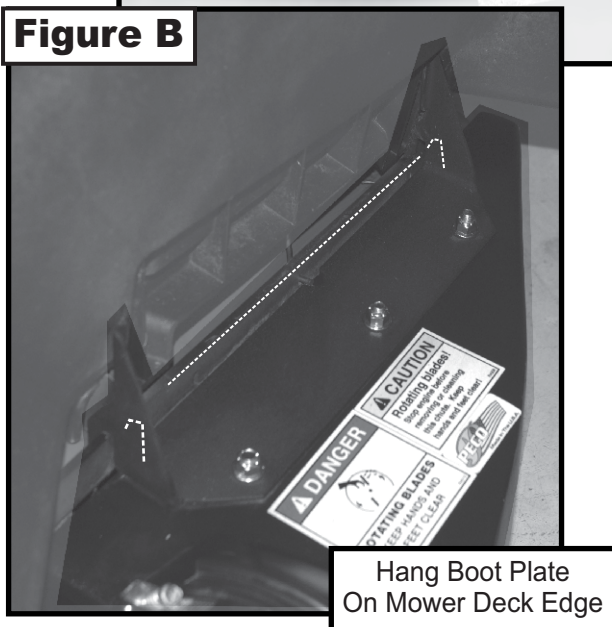
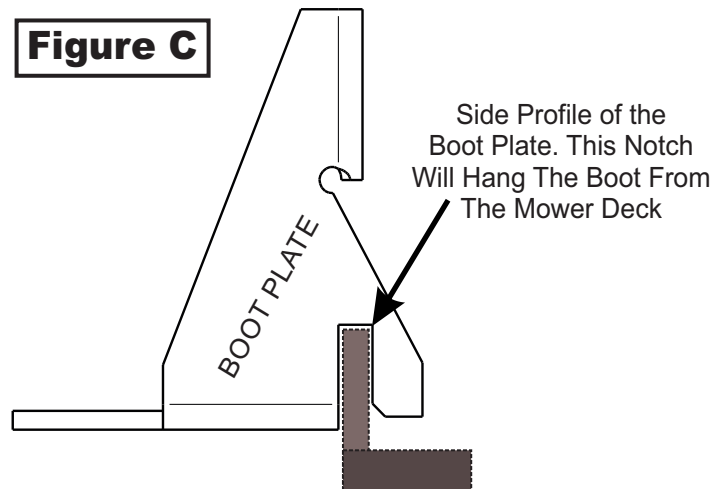

Figure C



Length Of Hose Adjustment

The hoses must be cut to fit your machine. Do not cut the hoses until you have tried to fit them on your machine. Remember that the hoses have to be long enough to adjust for the blower assembly's movement as well as allow for enough clamping surface between the inlet, blower assembly, and the deck boot.

Upper Hose Installation

Slide a pre-assembled hose clamp P#(J1000) onto both ends of the 6" upper hose (Figure A). Then slide one end of the 6" hose onto the plastic inlet P#(V1054) on the right side of the aluminum box assembly. Make sure there is about a two-inch overlap between the hose end and plastic inlet. Secure the hose ring with the locking pin. Proceed to slide the opposite end of the 6" hose onto the outlet of the blower assembly. See (Figure A) for details. Make sure both ends of the hose are clearly attached to the inlet and the blower assembly inlet. Tighten the hose clamps.

Lower Hose To Blower Cone Installation

Slide a pre-assembled hose clamp P#(J1000) over both ends of the lower hose. Then proceed to slide the lower hose onto the blower cone. Tighten the hose clamp. The assembly should look like Figure A.

Lower Hose To Boot Installation

Take the unattached end of the lower hose and slide it over the circular end of the boot. Use the lower hose clamp to secure the hose to the boot (Figure A). Tip: Before securing clamp rotate hose counter-clockwise (away from yourself) approximately 1" to aid in retaining boot to mower deck.

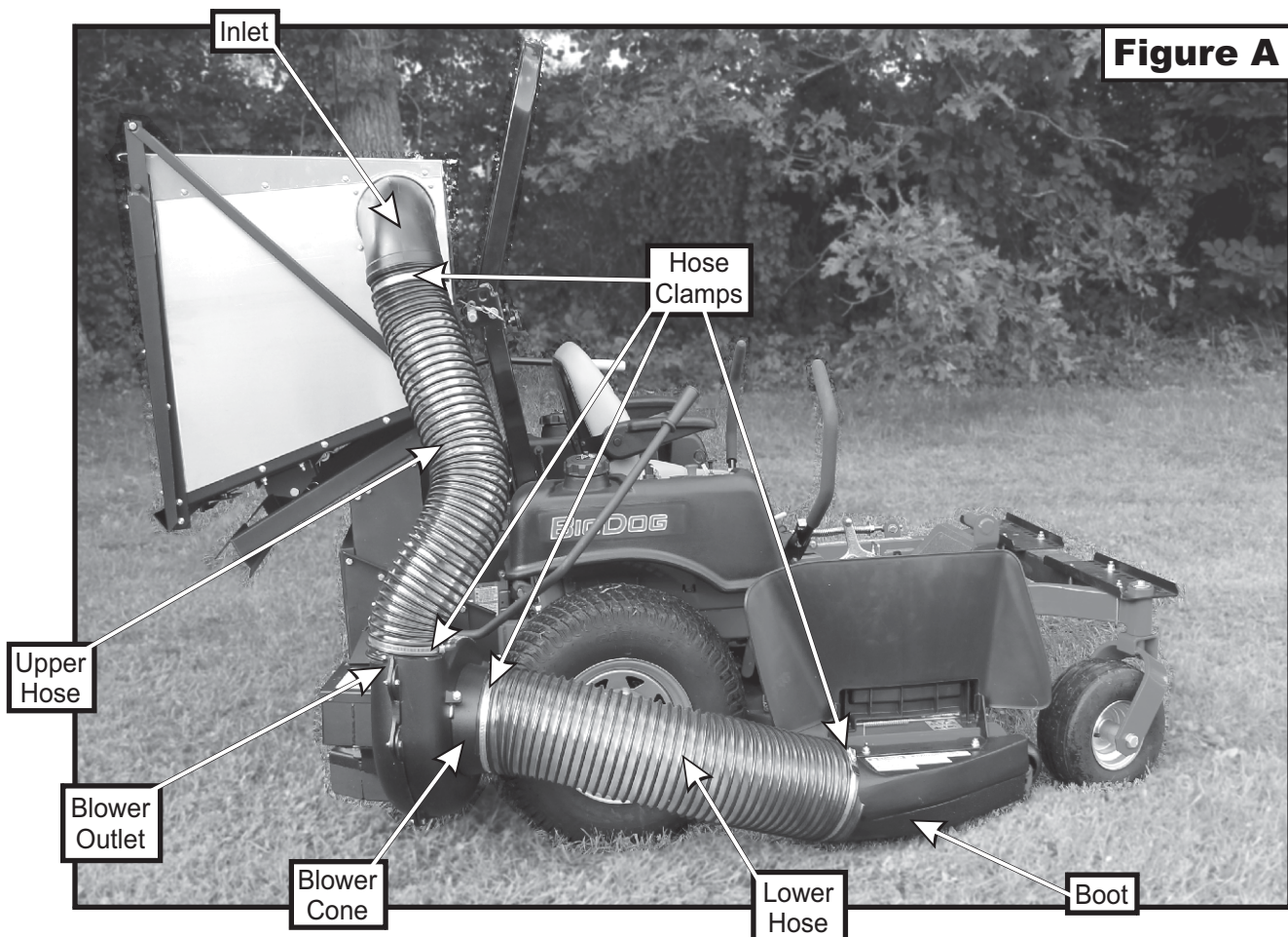

Impeller Blade Removal/Replacement

To gain impeller blade (#1) access, first remove the blower cone (#2) from the blower housing, located on the PTO assembly P#(A0623), by removing two blower cone bolts and nuts (#3). Next, remove the blower housing front (#4) by removing seven bolts and nuts (#5) around the outer housing edge. Refer to Figure A.

To Remove: First, remove one 3/8"-16 x 1-1/2" HHCS P#(K1211) (#6), one taper-lock bushing washer P#(K0278) (#7) and one spacer bushing P#(S3242) (#8) from the taper-lock bushing (#9). See Figure A. Next, remove two 1/4"-20 x 1" HHCS (#10) and place them into the threaded holes (#11) of the taper-lock bushing P#(S4302). Last, gradually thread each bolt evenly into the taper-lock bushing, forcing the blade to break-away from the taper-lock bushing.

Tips on removing impeller blade;

- 1 - Try carefully hitting the base of the impeller blade (#1), between each vein (#12), with a rubber mallet to loosen the taper-lock bushing hold.
- 2 - Spray break-free lubricant into the surrounding areas of the taper-lock bushing (#9) and repeat Tip 1.

To Replace: First, place the impeller blade (#1) over the drive shaft (#13). Next, slide the taper-lock bushing (#9) on to the drive shaft and into the impeller blade, aligning the **non-threaded** holes (#14) of the taper-lock bushing to the threaded holes of the impeller blade. Then, fasten by using two 1/4"-20 x 1" HHCS (#10), one spacer bushing (#8) one taper lock bushing washer (#7), and one 3/8"-16 x 1-1/2" HHCS (#6). Torque all bolts to the specifications located in the chart towards the back of this manual. Last, rotate the impeller blade to ensure that the blade is clear of contact on all sides of the blower housing.

Figure A

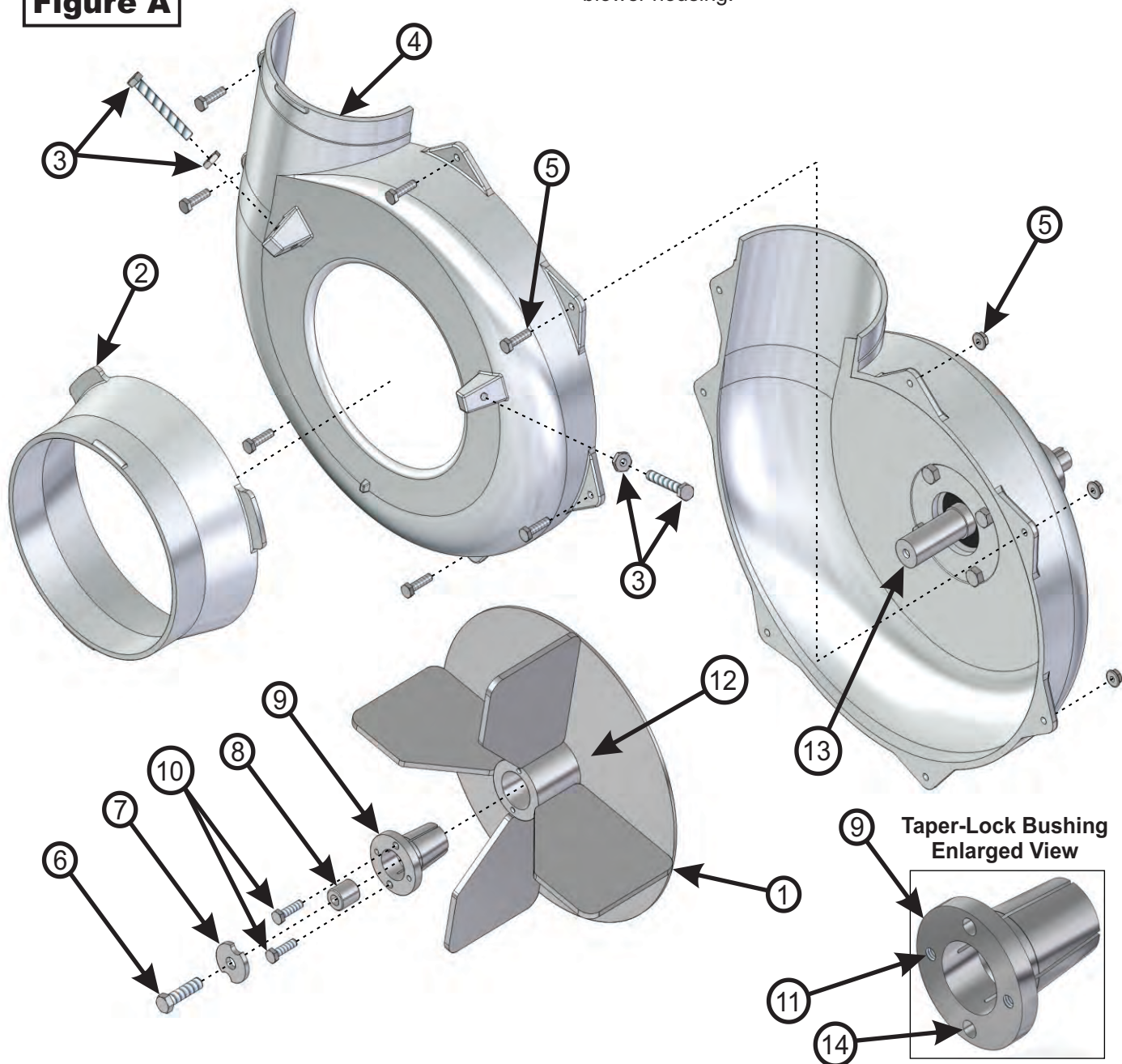

Weight Kit Installation

A weight kit must be installed to your unit as a counterweight for the collection system. This universal weight kit is designed to fit all series of Big Dog mowers. Depending on your mower series, the positioning of the weight brackets may need to be adjusted.

Secure the (2) weight brackets P#(B0039) to the front casters of the mower using (1) 3/8"-16 u-bolt P#(K1419) and (2) 3/8"-16 nylon flange lock nuts P#(K2012) PER Bracket. Insert the u-bolts from the bottom so that the locknuts are on top of the weight bracket.

NOTE: It is recommended that a support such as a floor Jack be used during the weight bar installation.

Lift the weight bar P(B0034) into position underneath the weight bracket. Secure the weight bar using (2) 12"-13 U-bolts P#(K0331) and (4) 1/2"-13 nylon flange locknuts P#(K2012). Refer to Figure A for reference.

TIP: Leave the hardware slightly loose until the weight brackets and weight bar have been positioned correctly. Once positioned, tighten the hardware.

Figure A



A1841_01 PTO Arm Assembly

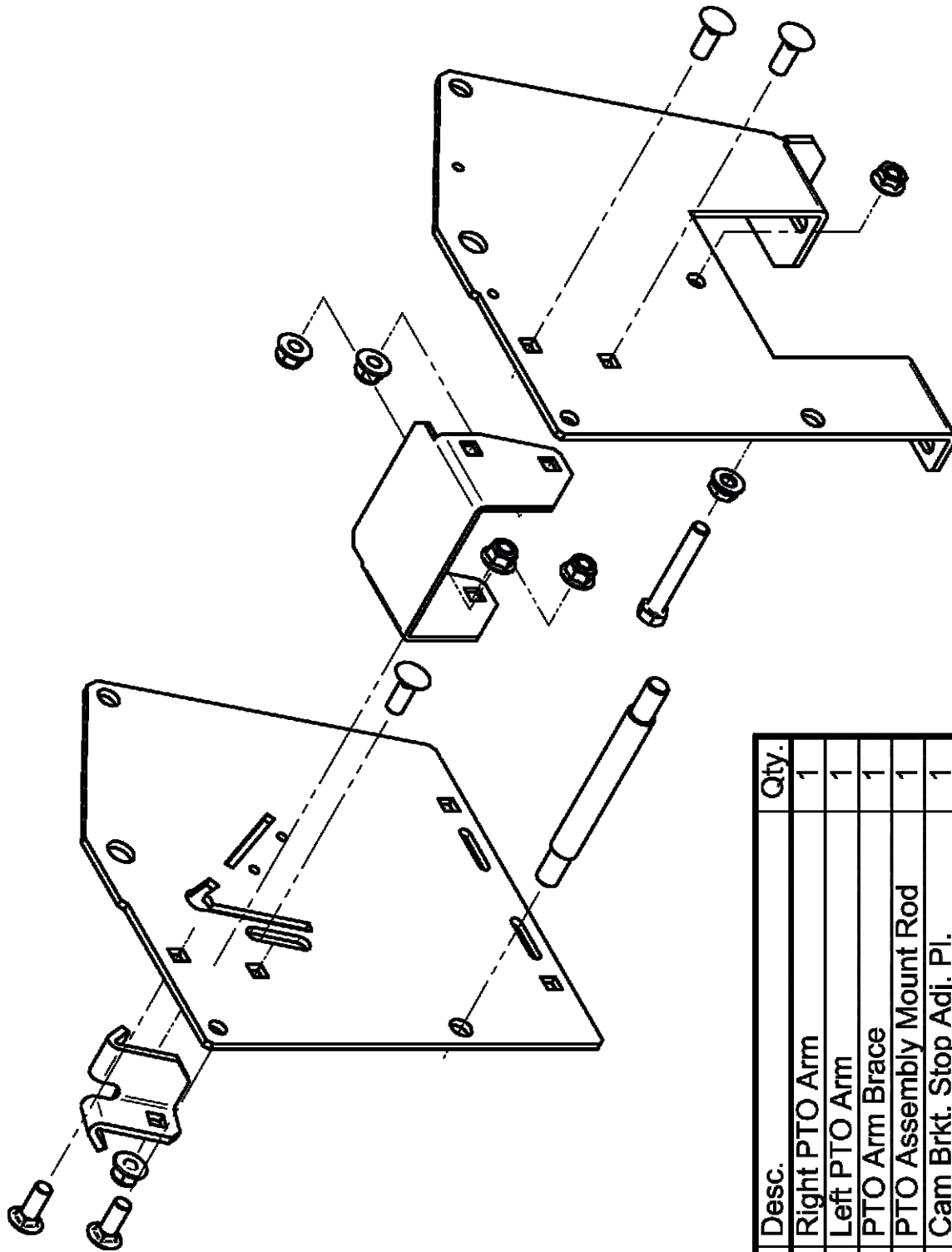

Item#	Part#	Desc.	Qty.
1	B0265 01	Right PTO Arm	1
2	B0266 01	Left PTO Arm	1
3	B0268 01	PTO Arm Brace	1
4	B0271 01	PTO Assembly Mount Rod	1
5	B0024 01	Cam Brkt. Stop Adj. Pl.	1
6	K1215	Flange Nut 3/8"-16	2
7	K1197	3/8"-16X2 1/2" HHCS	1
8	K1182	Carriage Bolt 3/8"-16x1"	5
9	K2038	Ny-Flange Lock Nut 3/8"-16	5

A1941_01 PTO Base Assembly Exploded Parts View

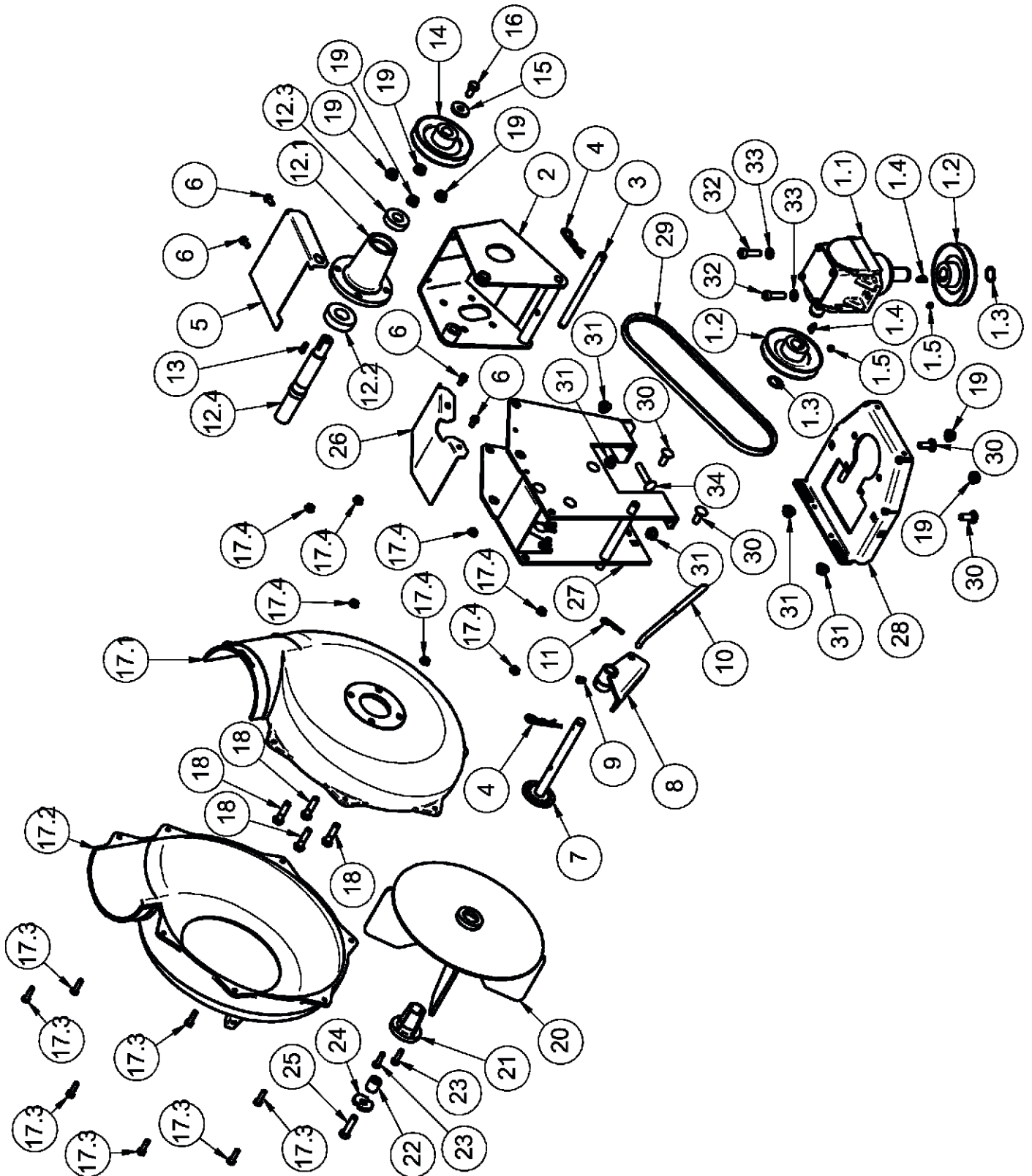

A1941_01 PTO Base Assembly Exploded Parts List

Item#	Part#	Desc.	Qty.
1	A0429	Gear Box Assy.	1
1.1	A0431	Gearbox	1
1.2	A0498	Pulley Assy. / GearBox	2
1.3	K0360	Snap Ring / 7/8"Shaft	2
1.4	J0272	Woodruff Key #9	2
1.5	K0035	Set Screw 5/16" -18x1/4" CupPoint	2
2	A0144	Blower Mnt. Brkt. Assy.	1
3	B1755	BLOWER PIVOT ROD	1
4	K0086	Hair Pin Clip.125ODx2.50	2
5	B0121	Blower Belt Guard	1
6	K0353	HWHTCS 1/4" -20x1/2"	4
7	A0604	PTO HANDLE MOUNT ASSY	1
8	A0422	CAM BRACKET ASSEMBLY	1
9	K0356	3/8"-16 TAPERED SET SCREW	1
10	K0326	BELT TENSION ROD 3/8"-16	1
11	K0130	.091ODx1.625L HAIR PIN CLIP	1
12	A0306	PTO Shaft Assy.	1
12.1	E0121	PTO Shaft Housing	1
12.2	N0147	Bearing (2.0472OD,0.9843ID,0.5906W)	1
12.3	N0148	Bearing (1.625OD,0.750ID,0.4375W)	1
12.4	B1758	PTO Shaft	1
13	J0254	Key / 3/16" x3/16" x3/4"	1
14	M0228	Pulley / Impeller Shaft	1
15	K1446	PTO Housing Washer	1
16	K1190	HHCS / 3/8"-16x3/4"	1
17	E4004A	BLOWER HSG. ASSY.	1
17.1	E4004B	BLOWER HSG. BACK	1
17.2	E4004F	BLOWER HSG. FRONT	1
17.3	K1125	HHCS 1/4" -20X1" GR2	7
17.4	K1126	Flange Nut 1/4" -20	7
18	K1193	HHCS 3/8" -16X1-1/2"GR5	4
19	K1215	Flange Nut 3/8"-16	6
20	A0645	4-Blade Impeller Assy	1
21	S4302	TAPER - LOCK BUSHING	1
22	S3242	Spacer Bushing / .750IDx.380IDx.830L	1
23	K1225	HHCS 1/4" -20X1" GR8	2
24	K0278	Double Indented Washer 7/16"1.375ODx.440IDx.179T	1
25	K1211	3/8"-16x1-1/2"HHCS GR8	1
26	B0270	PTO Arm Guard	1
27	A1804_01	PTO Arm Assembly	1
28	A0624_01	Base Plate Assembly	1
29	M0250	A30K KEVLAR BELT	1
30	K1182	Carriage Bolt 3/8"-16x1"	4
31	K2038	Ny-Flange Lock Nut 3/8"-16	5
32	K0309	3/8"-16x1-1/4"SHCS	2
33	K0048	Lock Washer 3/8"	2
34	K1184	Carriage Bolt 3/8"-16x2"	1

A0623 PTO Assembly w/ Small Pulley Guard Exploded Parts View

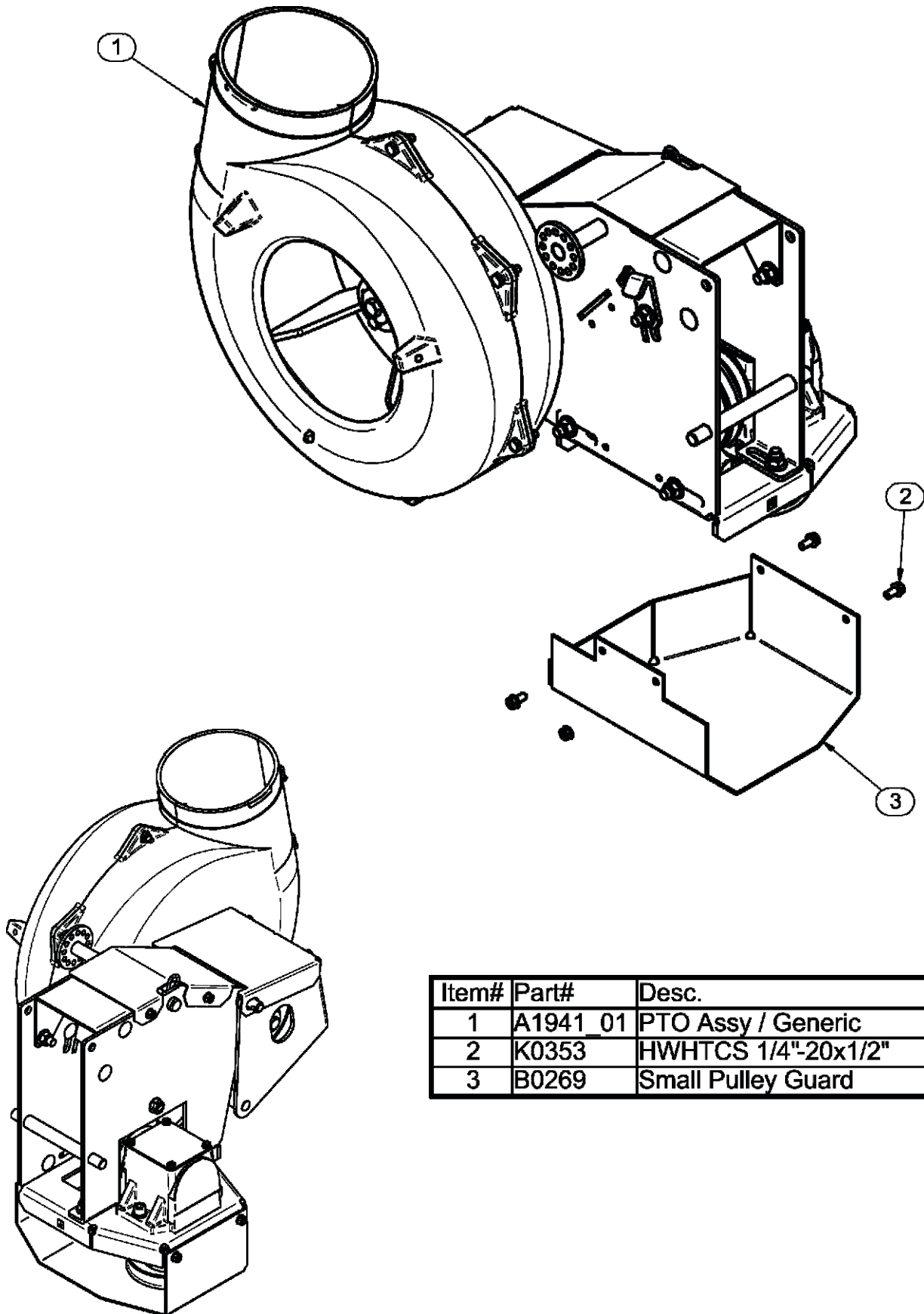

Item#	Part#	Desc.	Qty.
1	A1941 01	PTO Assy / Generic	1
2	K0353	HWHTCS 1/4"-20x1/2"	4
3	B0269	Small Pulley Guard	1

Unit Model #: 52621201

Mower Type: Big Dog X Series, X-Diablo, Diablo & DiabloMP

Owner's Manual: Q0471

Engine Type: Kawasaki Fx850, Fx1000v & Briggs 26

Deck Size: 52" & 60"

Vac Type: 12 Cu. Ft. Pro 12 DFS

Deck Type:

Drive Type: PTO Drive

Revision #: Rev. 1 - Updated For New Model Years / DD Feb 2015
Fits Year(s): 2013-2015



A1944 Boot Kit

(1) E0025 BOOT

(1) HB0578 HARDWARE BAG

(1) B0832 BOOT PLATE

A2021 Weight Kit

(1) HB0644 HARDWARE BAG

(2) B0034 12" LONG WEIGHTS

(2) B0039 WEIGHT BRACKETS

A1943 Mount Kit

(1) M0254 A59K KEV. CORD BELT

(1) HB0577 ENGINE PULLEY HARDWARE BAG

(1) HB0576 HARDWARE BAG

(1) E6009 8" BLOWER CONE

(2) J0080 8" HOSE CLAMPS

(1) B0826 LT. FRAME BRACKET

(1) B0825 RT. FRAME BRACKET

(1) A0626 PTO HANDLE

(1) A0623 PTO ASSEMBLY

(1) F0080 8" x 38" LOWER HOSE

(2) B0840 FRAME MNT. SPACER

(1) B0828 RT. PTO MNT. PL.

(1) B0831 MUFFLER GUARD

(1) B0829 LT. PTO MNT. PL.

(1) B0827 REAR FRAME BRACKET

A1947 Vac Kit

(1) V1054 PLASTIC INLET

(1) F0060 6" x 36" UPPER HOSE

(1) HB0580 HARDWARE BAG

(2) J0060 6" HOSE CLAMPS

(1) A0794 BOX ASSEMBLY

(1) A0614 BOX HANDLE ASSY.

(1) B0830 MAIN FRAME LEGS

(1) A0995 MAIN FRAME ASSEMBLY

(2) B2526 DOOR LINKAGE

SECTION III OPERATING INSTRUCTIONS

General Safety

Only qualified people familiar with this operator's manual and the mower's operator's manual should operate this machine.

Operation And Tips On Mowing

- A. Perform BEFORE EACH USE the maintenance list referenced in Section IV.
- B. Start mower.
- C. With the mower at high idle speed, engage the mower deck.
- D. While seated in the operator's seat, pull the engagement handle of the PTO assembly towards the operator's seat until the handle slides into position in the retaining slot. With the PTO assembly engaged, you can proceed to operate the control levers of the mower.

NOTE: If the collection system does not appear to be collecting the grass clippings, disengage the deck and PTO assembly, then, engage the parking brake and turn the mower off. Check upper and lower hoses for any clogs.

To obtain the maximum effectiveness from your collection system, the tips listed below should be followed:

- * Watch your speed- Normal conditions will allow a speed of up to approximately 4 mph, but thick, heavy damp conditions will require reduced ground speed.
- * Mow with sharp blades- A sharp blade cuts cleaner.
- * Wet grass and leaves will decrease effectiveness and will increase horsepower requirements.
- * Mow at higher cutting heights- Remove and mulch no more than 2" of grass length with each mowing. (Experts recommend not cutting off more than 1/3 of the grass blade length at any given time.)
- * Mow twice, at different height settings, (high, then low), if grass is extra tall.
- * Remember that horsepower requirements will vary with the mowing conditions such as type and height of turf grass, moisture content, amount of leaves, whether the terrain is flat or hilly, etc.

Disengagement Of The PTO Assembly

A. To disengage the PTO assembly, slide the engagement handle out of the retaining slot and push the engagement handle away from the operator's seat.

WARNING: The PTO assembly blades will continue to spin. DO NOT TOUCH the PTO assembly, pulleys, or the belt until the tractor is turned off. DO NOT adjust the belt tension until the mower is turned off. Refer to the Belt Installation section of the manual.

Unloading The Collection System

- A. Stop the forward movement of the mower, engage the parking brake.
- B. Disengage the mower deck.
- C. Disengage the blower.
- D. Verify that the dump area is clear.
- E. Push the dump handle, on the left of the operator, away from the unit. While holding the handle pushed away, move the handle upward. The container door will swing upward and the container will rotate downward. The container will release its contents.
- F. Once the contents of the container have fallen out, the container is ready to move back into its normal operating position. Pull the handle downward until positive latching is achieved.

NOTE: Do not allow collection system to become over-filled as potential damage may occur to your equipment. Also, be sure to clean the screen as needed.

SECTION IV MAINTENANCE

Maintenance Checklist

Before each use:

1. Check blades and spindles to be sure that no foreign objects, such as wire or steel strapping bands, are wrapped around them.
2. Inspect blades for wear. Replace if necessary. If it is necessary to sharpen the blades, remove the blades from the spindles before sharpening. DO NOT sharpen blades while still attached to the mower.

3. Make sure all shields are in place and in good condition. Repair or replace any missing or damaged shields.
4. Perform lubrication.
5. Listen for abnormal sounds, which might indicate loose parts, damaged bearings, or other damage. Correct any deficiency before continuing operation.
6. With the engine off, engage the blower assembly. Check the belt tension and inspect the pulley belt for cracks or tears.
7. Check for wear or deterioration of the upper or lower hoses. If there are any portions of the hose that have been torn or worn through, replace with genuine PECO parts.

After Each Use:

1. Clean all debris from machine especially from the container, underneath the belt shields, and safety decals. Replace any missing or illegible decals.
2. Inspect the unit for worn or damaged components. Repair or replace before the next use. Any replacement component installed during repair shall include the component's current safety decal specified by the manufacturers to be affixed to the component.
3. Check belt for proper tension.

4-2 Lubrication

Gearbox:

NOTE: The gearbox is filled with 6.0 oz. of Mobilube HD Plus 80W-90 oil and permanently sealed. There is no need for scheduled lubrication. The oil level should only be checked if a leak is observed or if a change in gearbox noise is noticed.

Operators are recommended to check for leaks weekly. If a leak is observed, both the gasket and the seals are recommended to be replaced.

Replace the oil using 5.5 oz. of the recommended Mobilube HD Plus 80W-90 oil. Be sure to not overfill.

Blower Assembly:

NOTE: The following is for older PTO models that contain a greaseable zirc fitting. Newer models contain maintenance-free bearings and are without a greasable fitting.

1. On initial use: Grease the fitting on the blower shaft.
2. Every 25 hours of use: Re-grease the grease fitting.

NOTE: Use only white lithium based grease for lubrication of the shaft on the blower assembly.

SECTION V - PARTS & SERVICE

5-1 Parts And Service Information

Collection system owners should record the name and telephone number of their Service Center. Your Service Center will be happy to supply replacement parts, accessories, and do any service or repairs to your collection system. If for any reason your Service Center is unable to service your collection system or supply replacement parts, contact New PECO, Inc. and include the following information on the chart below.

DOCUMENT THE FOLLOWING INFORMATION FOR FUTURE REFERENCE

Unit Model Number: _____

Unit Engine Size: _____

Unit Serial Number: _____

Date of purchase: ____ / ____ / ____

Dealer/Distributor Name: _____

Address: _____ **State:** _____ **Zip:** _____

Phone Number: _____

100 AIRPORT ROAD

ARDEN, NORTH CAROLINA 28704

(800) 438-5823 OR (828) 684-1234 FAX: (828) 684-0858

EMAIL: peco@lawnvac.com

WEBSITE: www.lawnvac.com

SAFETY DECALS

To promote safe operation, PECO supplies safety decals on all products manufactured. Damage can occur to safety decals either through shipment, use or reconditioning. Contact your local Service Center for replacement decals.



R2008



R2007



Part #: R1049
Operation



Part #: R1069
Warning - Turn Off Blower



Part #: R1053
Caution - Keep Hands And Body Clear



Part #: R1055
Dump Grass

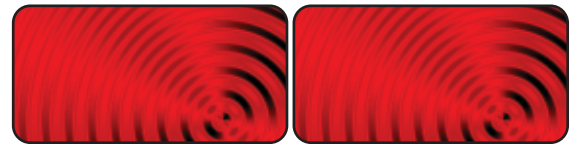

Part #: R1057
Red Reflector Label

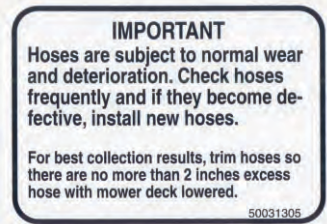

Part #: R1054
Important - Hose Wear



Part # R0024
Danger - Keep Hands Clear



Part# R0022
Designed & Built In The USA



Part #:R4008
Caution - Rotating Blades!



Part # R0025
Danger - Rotating Blades



Part #: R1051
Warning - Hearing Protection



Part #:R1083
Engage/Disengage



Part #: R1070
PECO Logo

TORQUE SPECIFICATIONS

Proper torque for American fasteners used on Peco equipment.
Recommended Torque in Foot Pounds (Newton Meters).*

AMERICAN

Bolt Head Markings

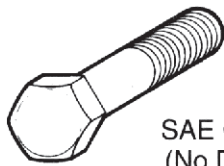

SAE Grade 2
(No Dashes)

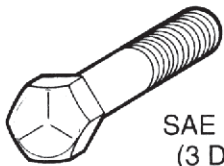

SAE Grade 5
(3 Dashes)

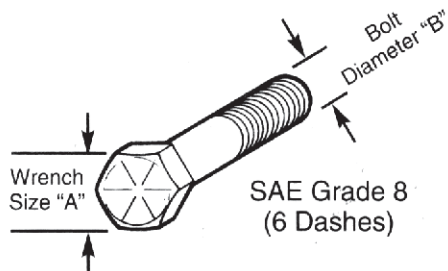

SAE Grade 8
(6 Dashes)

WRENCH SIZE (IN.) "A"	BOLT DIAMETER (IN.) "B" AND THREAD SIZE	SAE GRADE 2	SAE GRADE 5	SAE GRADE 8
7/16	1/4 - 20 UNC	6 (7)	8 (11)	12 (16)
7/16	1/4 - 28 UNF	6 (8)	10 (13)	14 (18)
1/2	5/16 - 18 UNC	11 (15)	17 (23)	25 (33)
1/2	5/16 - 24 UNF	13 (17)	19 (26)	27 (37)
9/16	3/8 - 16 UNC	20 (27)	31 (42)	44 (60)
9/16	3/8 - 24 UNF	23 (31)	35 (47)	49 (66)
5/8	7/16 - 14 UNC	32 (43)	49 (66)	70 (95)
5/8	7/16 - 20 UNF	36 (49)	55 (75)	78 (106)
3/4	1/2 - 13 UNC	49 (66)	76 (103)	106 (144)
3/4	1/2 - 20 UNF	55 (75)	85 (115)	120 (163)
7/8	9/16 - 12 UNC	70 (95)	109 (148)	153 (207)
7/8	9/16 - 18 UNF	79 (107)	122 (165)	172 (233)
15/16	5/8 - 11 UNC	97 (131)	150 (203)	212 (287)
15/16	5/8 - 18 UNF	110 (149)	170 (230)	240 (325)
1-1/8	3/4 - 10 UNC	144 (195)	266 (360)	376 (509)
1-1/8	3/4 - 16 UNF	192 (260)	297 (402)	420 (569)
1-5/16	7/8 - 9 UNC	166 (225)	430 (583)	606 (821)
1-5/16	7/8 - 14 UNF	184 (249)	474 (642)	668 (905)
1-1/2	1 - 8 UNC	250 (339)	644 (873)	909 (1232)
1-1/2	1 - 12 UNF	274 (371)	705 (955)	995 (1348)
1-1/2	1 - 14 UNF	280 (379)	721 (977)	1019 (1381)
1-11/16	1-1/8 - 7 UNC	354 (480)	795 (1077)	1288(1745)
1-11/16	1-1/8 - 12 UNF	397 (538)	890 (1206)	1444 (1957)
1-7/8	1-1/4 - 7 UNC	500 (678)	1120 (1518)	1817 (2462)
1-7/8	1-1/4 - 12 UNF	553 (749)	1241 (1682)	2013 (2728)
2-1/16	1-3/8 - 6 UNC	655 (887)	1470 (1992)	2382 (3228)
2-1/16	1-3/8 - 12 UNF	746 (1011)	1672 (2266)	2712 (3675)
2-1/4	1-1/2 - 6 UNC	870 (1179)	1950 (2642)	3161 (4283)
2-1/4	1-1/2 - 12 UNF	979 (1327)	2194 (2973)	3557 (4820)

METRIC

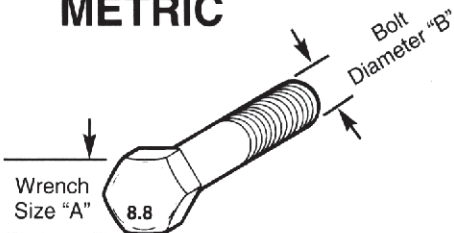

Numbers appearing on bolt heads indicate ASTM class.

Proper torque for metric fasteners used on Peco equipment.
Recommended torque in foot pounds (newton Meters).*

WRENCH SIZE (mm) "A"	BOLT DIA. (mm) "B"	ASTM 4.6	ASTM 8.8	ASTM 9.8	ASTM 10.9
8	5	1.8 (2.4)		5.1 (6.9)	6.5 (8.8)
10	6	3 (4)		8.7 (12)	11.1 (15)
13	8	7.3 (10)		21.1 (29)	27 (37)
16	10	14.5 (20)		42 (57)	53 (72)
18	12	25 (34)	74 (100)	73 (99)	93 (126)
21	14	40 (54)	118 (160)	116 (157)	148 (201)
24	16	62 (84)	167 (226)	181 (245)	230 (312)
30	20	122 (165)	325 (440)		449 (608)
33	22		443 (600)		611 (828)
36	24	211 (286)	563 (763)		778 (1054)
41	27		821 (1112)		1138 (1542)
46	30	418 (566)	1119 (1516)		1547 (2096)

*Use 75% of the specified torque value for plated fasteners. Use 85% of the specified torque values for lubricated fasteners.

NOTES



**10 WALDEN DRIVE
ARDEN, NORTH CAROLINA 28704
(800) 438-5823 OR (828) 684-1234 FAX: (828) 684-0858
EMAIL: peco@lawnvac.com
WEBSITE: www.lawnvac.com**