



**PTO
GRASS COLLECTION
SYSTEM**

DESIGNED FOR:

**MODEL# 23621209 & 23621212 (BOB-CAT)
43621206 & 43621209 (BUNTON)**



OPERATOR'S MANUAL

ASSEMBLY ● OPERATION ● MAINTENANCE

PECO GRASS COLLECTION SYSTEM

TABLE OF CONTENTS

| SECTION | PAGE | SECTION | PAGE |
|--|------|--|------|
| Safety ----- | 2 | 2-11 Boot Installation----- | 14 |
| Safety Alert Symbols----- | 3 | 2-12 Blower Cone Installation----- | 14 |
| Warranty ----- | 4 | 2-13 Impeller Blade Removal/Replacement----- | 15 |
| I INTRODUCTION AND DESCRIPTION----- | 5 | 2-14 Length Of Hose Adjustment----- | 16 |
| 1-1 Introduction----- | 5 | 2-15 Upper Hose Installation----- | 16 |
| 1-2 Description----- | 5 | 2-16 Lower Hose To Blower Cone installation----- | 16 |
| II INSTALLATION FOR USE----- | 5 | 2-17 Lower Hose To Boot Installation----- | 16 |
| 2-1 Preparation Of Mower----- | 5-6 | 2-18 Front Weight Installation----- | 16 |
| 2-2 PTO Assembly Installation----- | 6 | III OPERATING INSTRUCTIONS----- | 17 |
| 2-3 Main Frame Leg Installation----- | 7 | 3-1 General Safety----- | 17 |
| 2-4 Top Main Frame Assembly Installation----- | 7 | 3-2 Operation & Tips On Mowing----- | 17 |
| 2-5 Lift Handle Installation----- | 7 | 3-3 Unloading The Collection System----- | 17 |
| 2-6 Aluminum Grass Container Installation----- | 8 | IV MAINTENANCE----- | 17 |
| 2-7 PTO Handle Installation----- | 8 | 4-1 Maintenance Checklist----- | 17 |
| 2-8 Belt Installation----- | 8 | V PARTS AND SERVICE----- | 18 |
| Exploded Parts Views And Drawings----- | 9-13 | 5-1 Parts And Service Information----- | 18 |
| 2-9 Dump Mechanism Adjustment----- | 14 | Safety Decals----- | 19 |
| 2-10 Cam Assembly Adjustment----- | 14 | Torque Specifications----- | 20 |

Safety

- 1.** Read the operator's manual carefully and familiarize yourself with the proper use of your attachment. Do not allow anyone who is not acquainted with the Safety Instructions to use your attachment.
- 2.** Know the controls and how to stop quickly. **READ THE OPERATOR'S MANUAL!**
- 3.** Do not allow children to operate the vehicle. Do not allow adults to operate it without proper instruction.
- 4.** Be especially watchful of children and pets darting into the area while operating.
- 5.** Keep your eyes and mind on your unit while mowing or operating your attachment. Don't let others distract you.
- 6.** Do not attempt to operate your unit or mower when not in the driver's seat.
- 7.** Always stop unit when emptying the container.
- 8.** Stop unit, shut off deck attachment, set parking brake, shut off mower engine and remove spark plug wire before removing clogs, removing or replacing hose, boot, blower cone, or performing any maintenance.
- 9.** Mow up and down the face of slopes (not steeper than 10 degrees); never across the face of the slope.
- 10.** It is recommended that the container be kept only half full when negotiating any slopes. Start mowing on slopes when the container is empty.
- 11.** Inspect your lawn and remove any foreign objects before mowing. Never deliberately run the mower across any foreign object.
- 12.** Wear ear protection if the noise level is offensive.
- 13.** Wear eye protection to prevent debris from damaging your eyes.

SAFETY

WARNING! NEVER operate the mower unless the discharge guard and either the deflector assembly or the vacuum collector adapter are fastened securely in place.

WARNING! Do not work around the mower deck boot or the blower area until you are certain that the mower blades and the blower impeller have stopped rotating.

WARNING! To avoid serious injury, perform maintenance on the vacuum collector; **ONLY AFTER STOPPING THE MOWER'S ENGINE AND WAITING FOR ALL MOVING PARTS TO COME TO A COMPLETE STOP.** Set the parking brake. Always remove the ignition key before beginning maintenance.

WARNING! For your own personal safety, **ALWAYS** mow **UP** and **DOWN** the face of slopes and **NEVER** across the face. **NEVER** attempt to mow excessively steep slopes, and use caution when turning on any slope.

Safety Alert Symbol



This Safety Alert Symbol means: **“ATTENTION! BECOME ALERT! YOUR SAFETY IS INVOLVED!”**

This symbol is used to call attention to safety precautions that should be followed by the operator to avoid accidents. When you see this symbol, carefully read the message that follows and heed its advice. Failure to comply with safety precautions could result in death or serious bodily injury.

Safety Signs

The signal words **DANGER**, **WARNING**, and **CAUTION** are used on the equipment safety signs. These words are intended to alert the viewer to the existence and the degree of hazard seriousness.



White letters on **RED**

This signal word indicates a potentially hazardous situation which, if not avoided, will result in death or serious injury.



Black letters on **ORANGE**

This signal word indicates a potentially hazardous situation which, if not avoided, could result in death or serious injury.

It may also be used to alert against unsafe practices.



Black letters on **YELLOW**

This signal word indicates a potentially hazardous situation exist which, if not avoided, will result in minor or moderate injury.

It may also be used to alert against unsafe practices.

PECO LIMITED WARRANTY FOR NEW PRODUCTS

A. WHAT IS WARRANTED?

PECO extends the following warranties to the original purchaser of each new PECO consumer product subject to the following limitations:

- 1. PRODUCT WARRANTY:** Any part of any consumer product, which is defective in material or workmanship as delivered to the purchaser will be repaired or replaced, as PECO elects, without charge for parts or labor, if the defect appears within 12 months from the date of delivery of the product to the original purchaser. **ALL DEFECTIVE PARTS MUST BE RETURNED TO PECO FOR INSPECTION TO DETERMINE VALIDITY OF WARRANTY CLAIMS.** Freight and mailing will be borne by the customer.
- 2. PARTS REPLACED DURING WARRANTY:** Any new PECO part which is furnished in performance of this warranty and is defective in material or workmanship as delivered to the purchaser will be repaired or replaced, as PECO elects, without charge if the defect appears within 90 days from the date of installation of such part or before the expiration of the original warranty period, whichever is later.

B. SECURING WARRANTY ADJUSTMENTS.

Call PECO for Return Authorization. Damaged or broken parts, other than engines or batteries, must be returned to PECO Inc., 100 Airport Road, Arden, NC 28704 before any warranty adjustment can be authorized. At the time of requesting warranty adjustment, the purchaser must present evidence for date of delivery of the product. The purchaser shall pay any charge for the product to and from Arden, NC.

C. ITEMS NOT COVERED BY PECO WARRANTY.

Engines and batteries attached to PECO products are covered under a separate warranty by the respective manufacturer.

D. UNAPPROVED ALTERATION OR MODIFICATION.

All obligations of PECO Inc., under this warranty, shall be terminated if products are altered or modified in ways not approved by PECO Inc..

E. ACCIDENTS AND NORMAL MAINTENANCE.

The warranty covers only defective material and workmanship. It does not cover depreciation or damage caused by normal wear, accident, improper use or abuse of products. The cost of normal maintenance and normal replacement of service items such as belts, cutting blades, hoses, etc., which are not defective shall be paid for by the purchaser.

F. NO REPRESENTATIONS ADDITIONAL WARRANTIES, DISCLAIMER.

Neither PECO Inc. nor any company affiliated with it makes any warranties, representations or promises as to the quality of performance of its products other than those set forth herein. Except as described above, PECO Inc. makes no other warranties **AND SPECIFICALLY DISCLAIMS ANY AND ALL IMPLIED WARRANTIES OF FITNESS AND MERCHANTABILITY.**

G. ANY MACHINE USED FOR RENTAL PURPOSES ARE GUARANTEED FOR 45 DAYS FROM DATE OF ORIGINAL SALE ONLY.

H. REMEDIED EXCLUSIVE.

The only remedies the purchaser has in connection with the breach or performance of any warranty on PECO Inc. consumer products are set forth above. In no event will PECO be liable for special incidental or consequential damages.

1. NO SERVICE CENTER WARRANTY.

The selling Service Center makes no warranty on his own on any item warranted by PECO Inc. unless he delivers to purchaser a separate written warranty certificate specifically warranting the item. The dealer has no authority to make any representation or promise on behalf of PECO or to modify the terms of this warranty in any way.

SECTION I

INTRODUCTION AND DESCRIPTION

1-1 Introduction

We are pleased to have you as a PECO customer. Your collection system has been designed to give you a low maintenance, simple, and effective way to collect the grass clippings from your mower. This manual is provided to give you the necessary instructions to properly mount and operate the collection system on your mower. Please read this manual thoroughly. Understand what each control is for and how to use it. Observe all safety decal precautions on the machine and noted throughout the manual.

NOTE: all references made to right, left, front, rear, top or bottom are as viewed from the normal operator's position on the mower.

1-2 Description

The collection system is designed for turf maintenance where there is a need to collect the grass clippings as the mower cuts the turf. It is also good for picking up leaves and twigs in pre-season and post-season clean-up. The blower, mounted on the right side of the unit, uses a belt and gearbox system from the engine PTO shaft. Drive train protection comes through belt slippage. The blower draws grass clippings from the discharge area of the cutter deck up to the aluminum container mounted over the rear portion of the frame. The operator can engage the blower with a push of the over-center linkage on the right side of the unit. Once the container is full of clippings, the operator can easily push and raise the lift handle, releasing the container's rear door and the container will pivot towards the ground.

Section II

INSTALLATION FOR USE

2-1 Preparation Of Mower

Carefully dismantle wooden shipping crate from around the components. Cut retaining straps and separate the parts. The collection system will have various parts located inside. Remove and sort all parts for easy identification.

NOTE: before each step of assembly it will help to study the exploded drawings on pages 8 - 12.

From the underside of the engine remove the bolt and bushing from the electric clutch assembly. Replace these parts with the engine pulley assembly P#(A0419), 7/16" lock washer P#(K0053), and 7/16"-20 x 4" HHCS P#(K0359). The added pulley will power the collection system. Note that the center of the hub that is extended should be upward toward the engine (Figure 2-1a). Torque the bolt to 55 ft./lbs.

Figure 2-1a

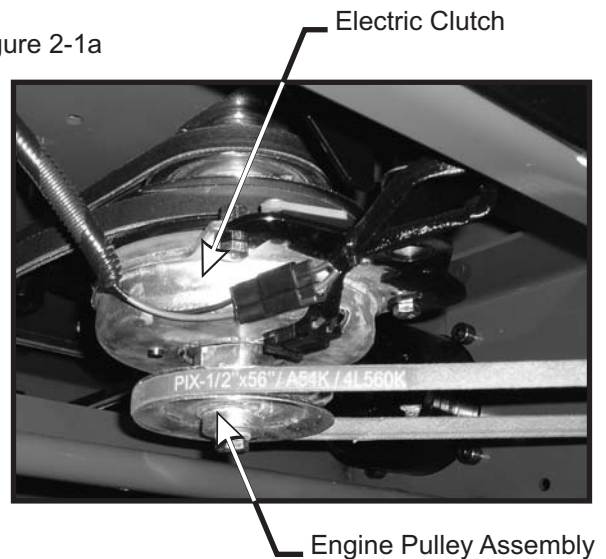

On the rear chassis of the mower drill four 13/32" holes (2 per side). There are several ways of doing this, the best is to remove the bolt that connects the lower rear bumper to the mower's chassis (Figure 2-1b) and loosely fasten the main frame legs P#(A0679) and P#(A0681) with the existing bolt and nut to use as a template. Use a center punch to mark the holes, then remove the main frame leg to drill the holes. See Figure 2-1b for reference.

Another way to mark the holes is to use the full scale drill template to center-punch the holes (Page 19), or by using the dimensions provided on the drill template for laying out the holes. We recommend when laying out the holes to use a square and a metal scribe.

Figure 2-1b

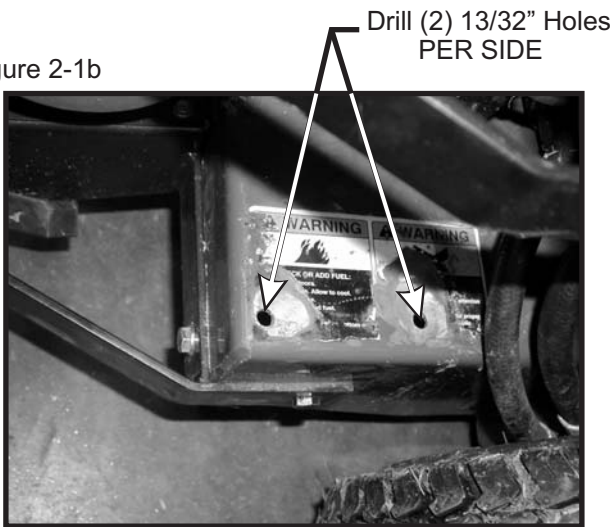

USE TEMPLATE ON PAGE 21

NOTE: The mower's exhaust radiates heat from the muffler which can be potentially drawn through the air intake. Provided is a heat guard to reduce the heat drawn into the air intake.

Remove the (2) bolts shown (Figure 2-1c) from the rear of the mower. Place the heat guard P#(C0011) over top of the muffler with the flap pointing downward so that the heat will travel to the rear of the mower. Align the holes in the heat guard to the holes of the bolts that were removed previously from the mower. Using the previously removed bolts, fasten the guard to the rear of the mower. See Figure 2-1c for more details on how to position heat guard.

Figure 2-1c

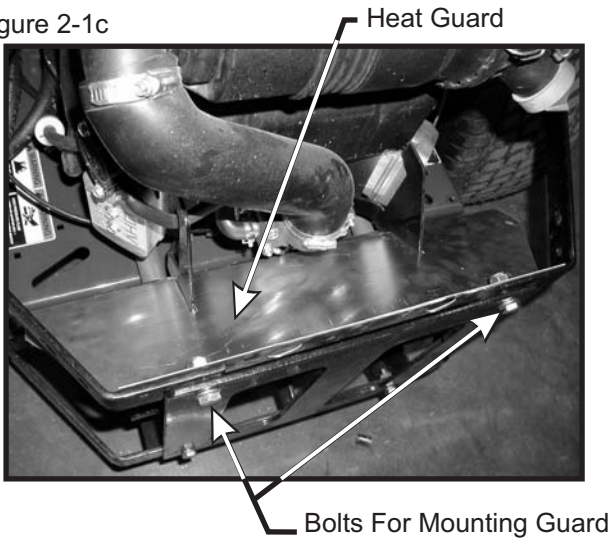

Note: If equipped with a Donaldson air cleaner, rotate unit for clearance of the top main frame assembly. To rotate Donaldson air cleaner, loosen spring tension bolt on air cleaner bracket, rotate air cleaner as needed for clearance as shown in Figure 2-1d, and tighten.

Figure 2-1d

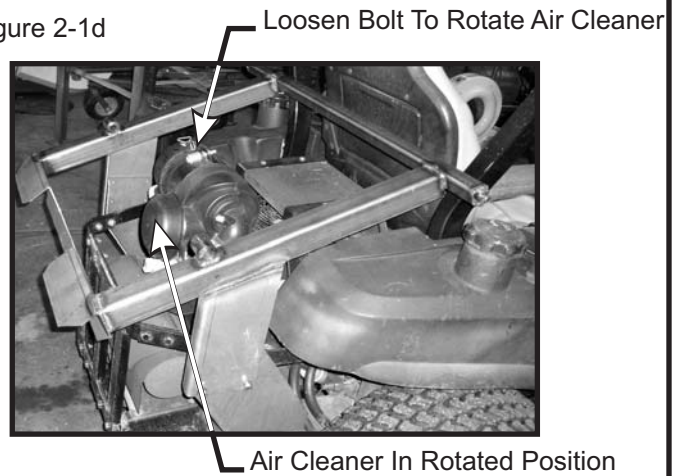

NOTE: If air cleaner still touches after installing box assembly P#(A0794), there is adjustability designed into the frame legs. Raise the main frame assembly P#(A0680) up one set of holes as needed for clearance. Always keep the lowest height to ground clearance possible for the collection system, which will improve overall stability.

NOTE: PREDATOR PRO MODELS SEE PAGE 13

2-2 PTO Assembly Installation

Position the PTO assembly over the holes that were drilled in the right rear mower chassis. Fasten the assembly using (2) 3/8"-16 x 1" HHCS P#(K1191) and (2) 3/8"-16 flange nuts P#(K1215). See Figure 2-2 for reference.

Figure 2-2

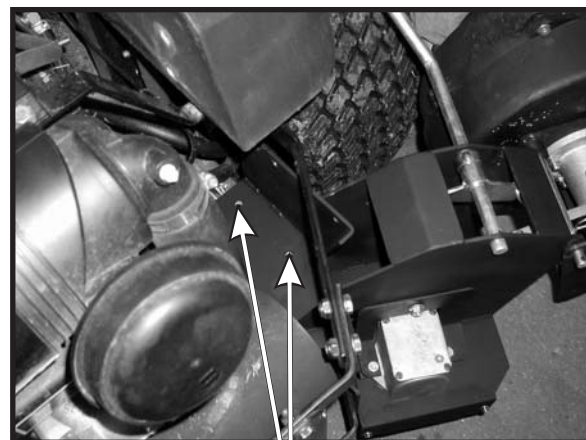

2-3 Main Frame Leg Installation

Install the left lower frame leg assembly P#(A0681) to the rear left side of the chassis by using (2) 3/8"-16 x 1" HHCS P#(K1191), (2) 3/8"-16 flange nuts P#(K1215), and (1) nut and bolt previously removed from the mower. Refer to the figures below.

Figure 2-3a

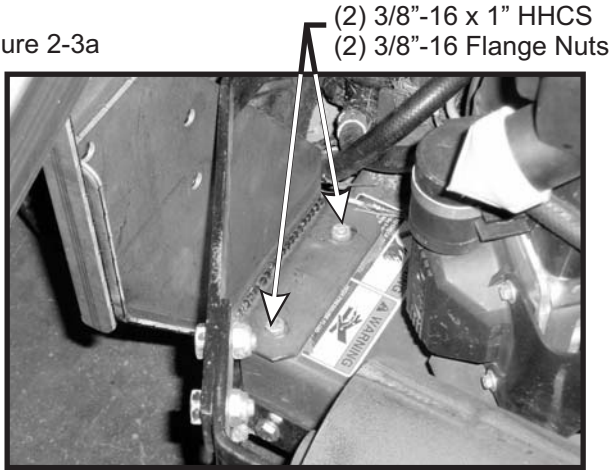
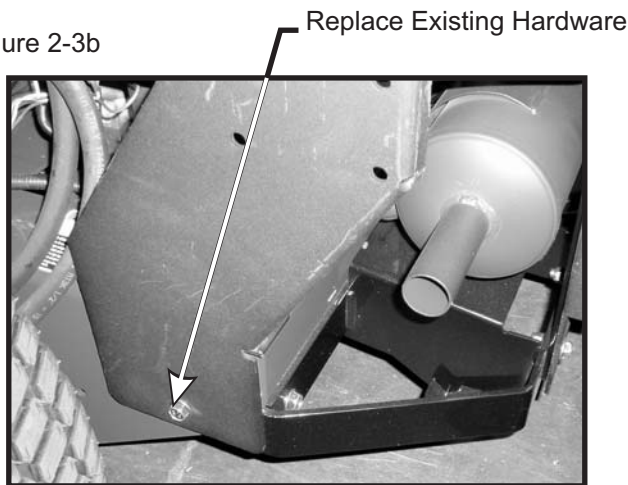

Figure 2-3b



2-4 Top Main Frame Assembly Installation

Place the top main frame assembly P#(A0680) (Figure 2-3) onto the main frame legs in the lowest hole possible for clearance, and fasten by using (4) 3/8"-16 x 1" HHCS P#(K1191) and (4) 3/8"-16 flange nuts P#(K1215), (2) bolts and nuts per side.

NOTE: This mower comes with different engine options. Diesel and water-cooled engines may cause the main frame assembly to be mounted in a higher hole location for clearance. The main frame legs are designed with multiple mounting holes for adjustability. Always mount the main frame assembly in the lowest set of holes possible for clearance. Doing this will provide the lowest height-to-ground clearance for the collection system, which will improve overall stability. See Figure 2-4.

Figure 2-4

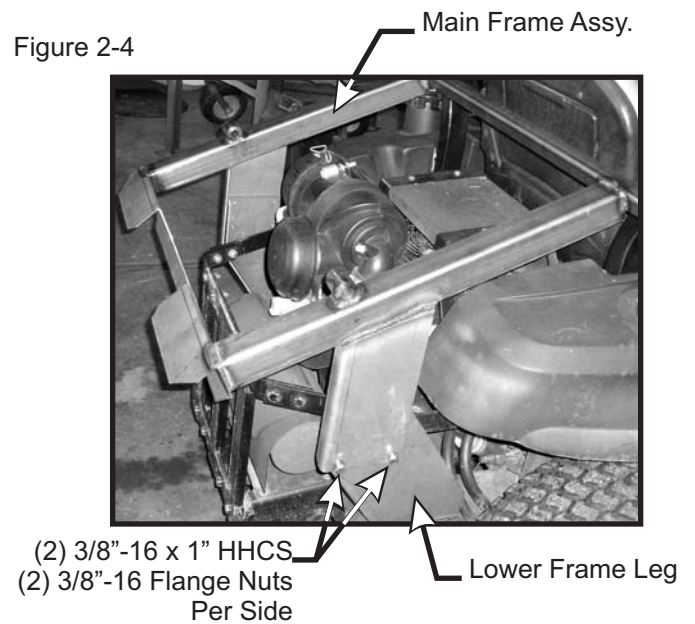

2-5 Lift Handle Installation

The various parts of the handle assembly P#(A0273) must be attached to the container frame. Page 9 shows the orientation and location of the components. Slide the lift handle into the slot in the handle mount bracket P#(B1730) on the grass container. It may be necessary to remove the handle grip P#(J0522) to allow the handle to fit through the slot.

Before attaching the handle, hook one end of the spring P#(J0176) into the hole on the underside of the handle. Hook the other end of the spring into the open hole in the handle mount bracket. Fasten the handle to the grass container frame by using (1) 3/8"-16 x 2" HHCS P#(K1208) and (2) 3/8"-16 flange nuts P#(K1215). At this point the handle can pivot back and forth in the slot of the handle mount bracket. With the handle in place, fasten the ball joint P#(K1442) to the end of the latch rod P#(A0260) (Page 8). Tighten to approximately half way down the threads of the latch rod. Slide the ball joint into the hole on the latch hook P#(B1529). Use (1) 5/16"-24 hex nut P#(K1444) and (1) 5/16" lock washer P#(K0043) to fasten the ball joint to the latch hook. Attach the opposite end of the latch rod into the handle. Fasten the rod to the handle by using (1) 3/32" x 3/4" cotter pin P#(K0094). Adjust the rod to allow the hook to close the box door completely.

Refer to pages 9-12 for exploded parts drawings and photographs of the complete assembly.

2-6 Aluminum Grass Container Installation

NOTE: It is recommended that (3) people assist in mounting the container.

With three people available, two can lower the container onto the frame while the third person inserts the pivot pins P#(K0172) through the holes. Insert the pins from the outside to the inside. Secure with (1) 5/8" washer P#(K0058) and (1) 5/32" x 2-5/8" hair pin clip P#(K0088) per pivot pin (Figure 2-6).

Reattach the bottom ends of the door opening linkages to the main frame by using (1) Rue-Ring cotter pin P#(K1437) per side.

To test the functionality of the dump mechanism, pull the lift handle away from the unit, and lift upward (Page 9). The door of the container should open and the box should pivot clockwise towards the ground.

Figure 2-6

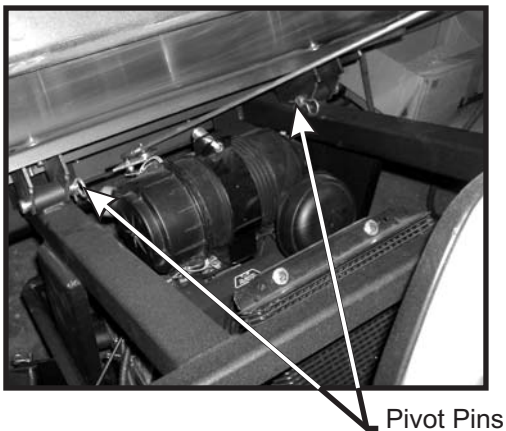

2-7 PTO Handle Installation

NOTE: 2007 And Later Models Only
Fasten the PTO handle P#(A0623) to the PTO assembly using (3) 1/4"-20 x 3/4" HHCS P#(K1222) and (3) 1/4"-20 nyloc nuts P#(K1128) See Figure 2-7 for reference.

Figure 2-7

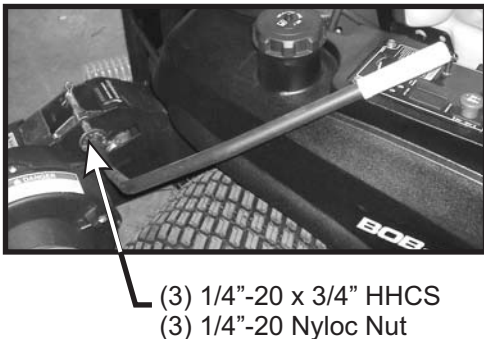

2-8 Belt Installation

Loosen the (2) bolts that secure the gear box assembly P#(A0429) to the pto mount plate (Figure 2-8a). Loosen the adjustment bolt P#(K0348) until the gear box assembly is at it's far left adjustment, (the gear box is moved towards the mower's engine pulley). Connect the A52K kevlar chord belt P#(M0238) from the engine pulley to the lower gear box pulley (Figure 2-8b).

To tension the drive belt, turn the adjustment bolt clockwise until there is 1" of deflection, with 10-11 lbs. Of pressure between the engine pulley and the gear box pulley.

Once the correct tension of the belt is achieved, tighten the (2) bolts that secure the gear box assembly.

Figure 2-8a

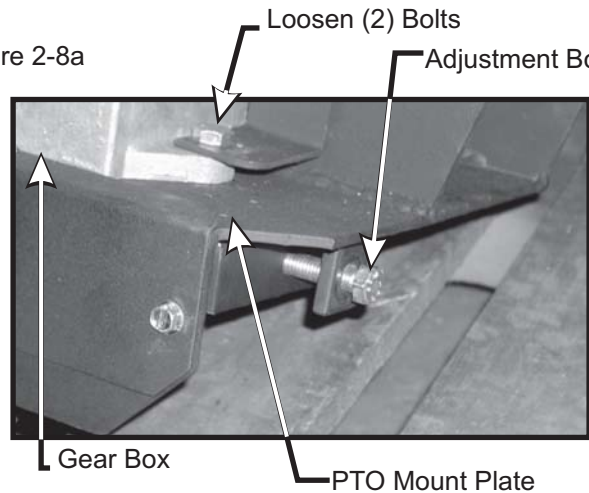
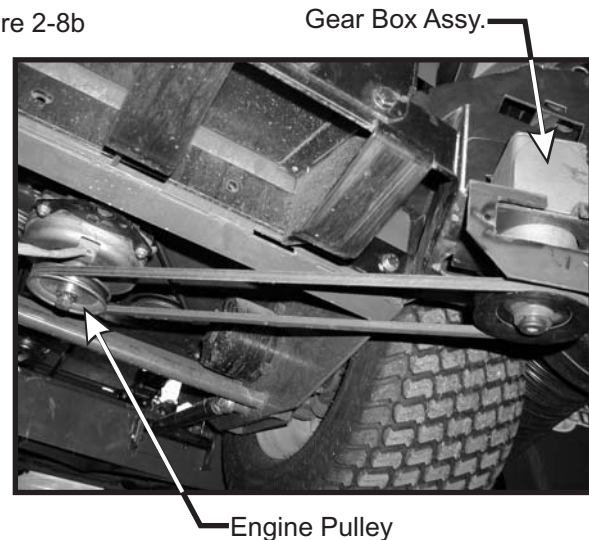
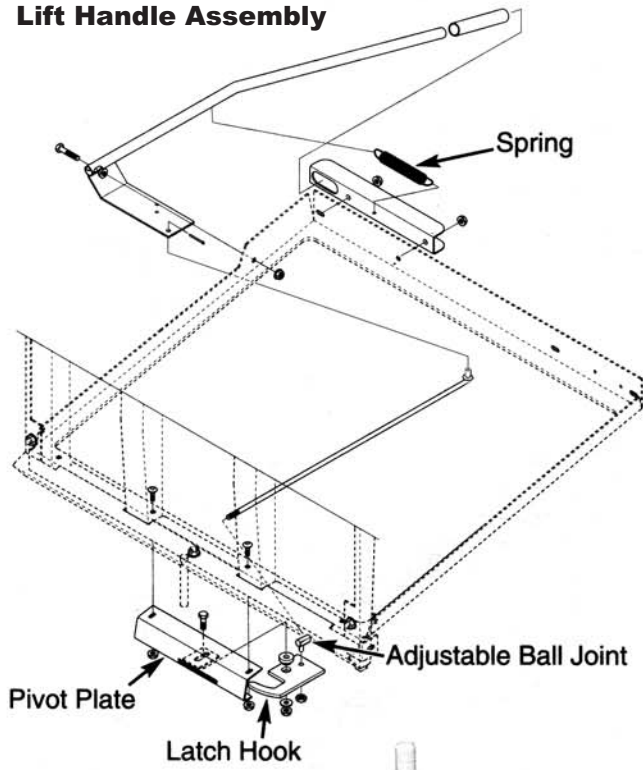

Figure 2-8b



Lift Handle Assembly



Aluminum Grass Container Assembly

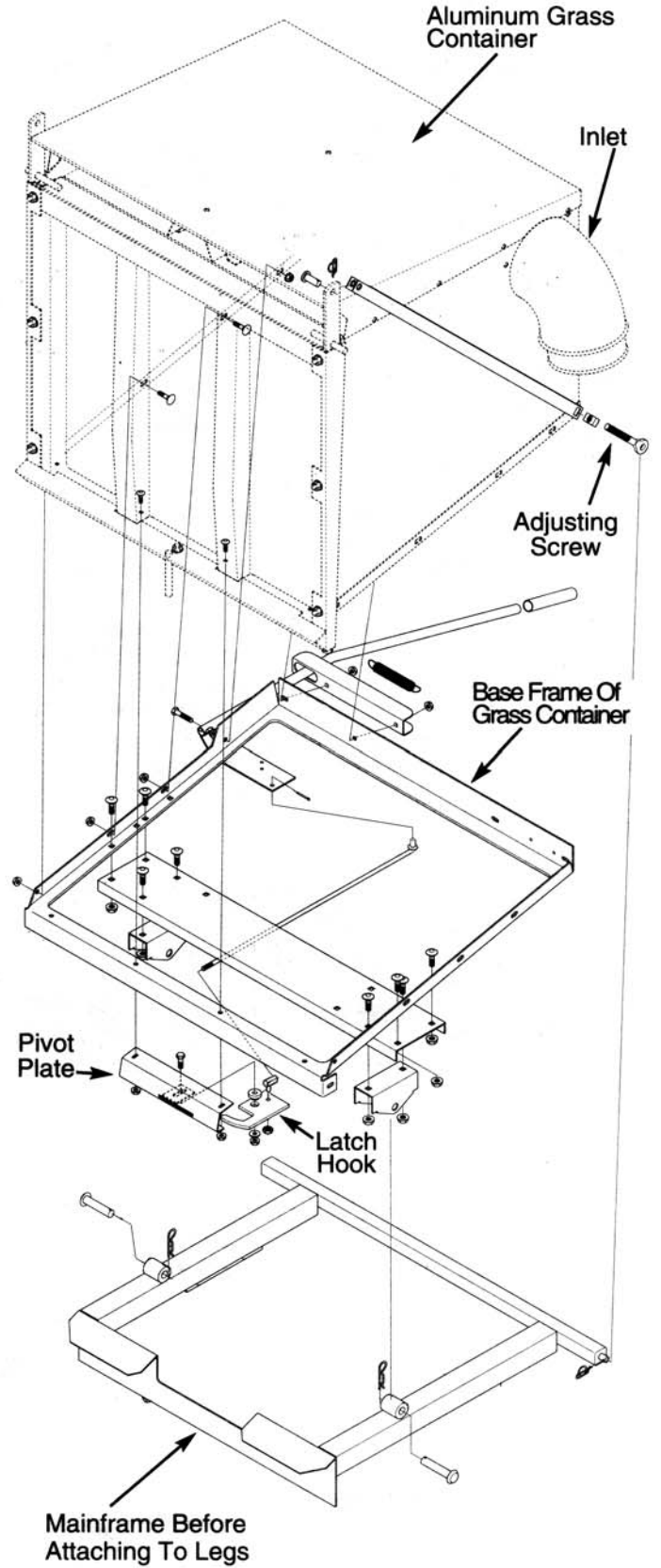

Aluminum Grass Container With Handle Attached



Latch Hook Mechanism Assembly

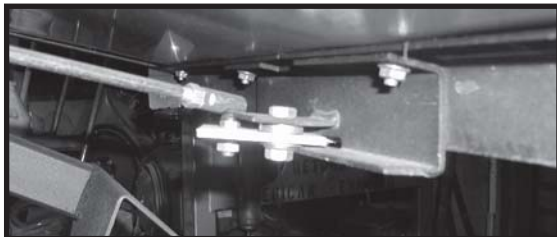

**Aluminum Grass
Container
Exploded View**

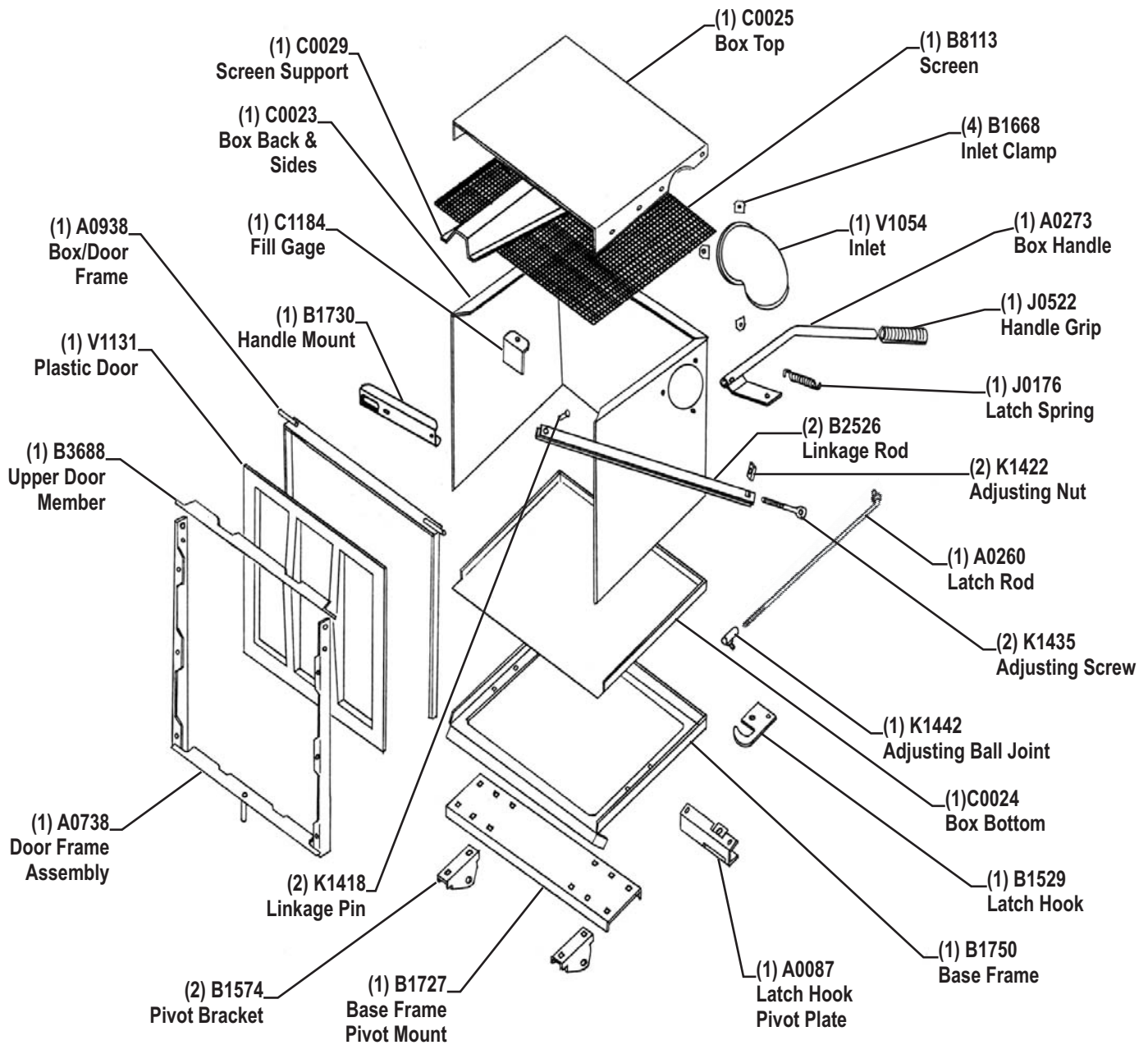

□ A0685 UNIT ASSY.

2006 AND BELOW

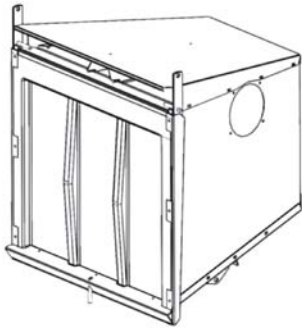

**A0794
12 CU. FT.
BOX ASSY.**



**(1)
V1054
6\"/>**



**(2)
J6006
7\"/>**



**(1)
HB0254
HARDWARE
BAG**

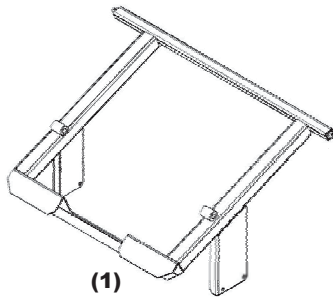

**(1)
A0680
MAIN FRAME
ASSY.**

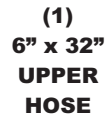

**(1)
6\"/>**

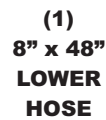

**(1)
8\"/>**

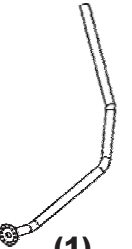

**(1)
A0273
BOX HANDLE**

**(1)
A0626
PTO
HANDLE**

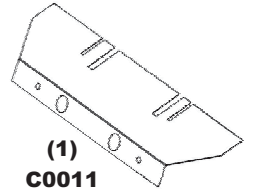

**(1)
C0011
HEAT GUARD**

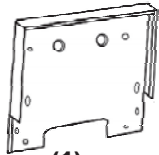

**(1)
B0047
REAR MOUNT
PLATE**



**(1)
E6009
8\"/>**

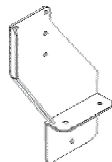

**(1)
A0681
LT. LOWER
FRAME LEG
ASSY.**

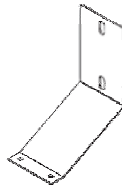

**(1)
B0276
AIR CLEANER
MOUNT BRACE**



**(1)
B0275
AIR CLEANER
MOUNT PLATE**

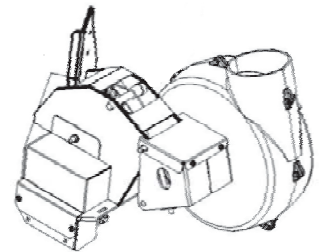

**(1)
A0739
PTO
ASSEMBLY**

□ A0683 WEIGHT KIT



**(1)
HB0120
HARDWARE
BAG**

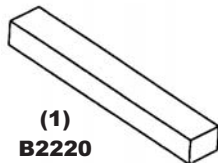

**(1)
B2220
WEIGHT**

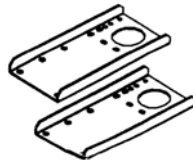

**(2)
B0026
WEIGHT
BRACKET**

□ A0684 BOOT KIT



**(1)
HB0078
HARDWARE
BAG**

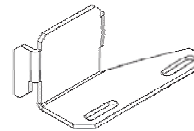

**(1)
B0079
BOOT
PLATE**



**(1)
E1030
BOOT**

A0988 UNIT ASSY.

2007 MODELS

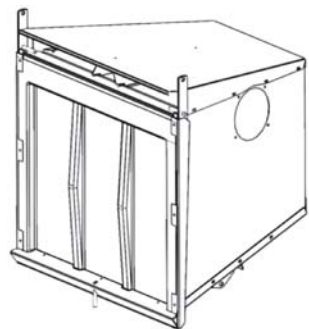

(1)
A0794
12 CU. FT.
BOX ASSY.



(1)
V1054
6" PLASTIC
INLET



(2)
J6006
7" - 8"
HOSE CLAMPS



(1)
HB0329
HARDWARE
BAG

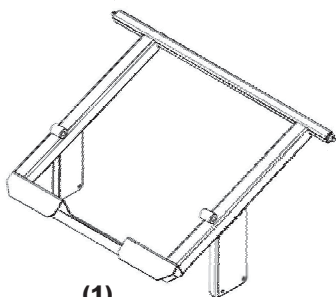

(1)
A0680
MAIN FRAME
ASSY.

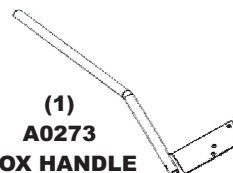

(1)
A0273
BOX HANDLE

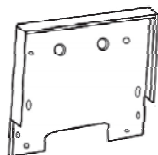

(1)
B0047
REAR MOUNT
PLATE

(1)
6" x 32"
UPPER
HOSE



(1)
7" x 48"
LOWER
HOSE



(1)
B0275
AIR CLEANER
MOUNT PLATE

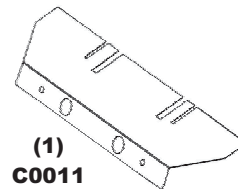

(1)
C0011
HEAT GUARD

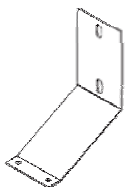

(1)
B0276
AIR CLEANER
MOUNT BRACE



(1)
E6004
7" BLOWER
CONE

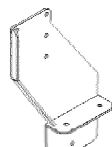

(1)
A0681
LT. LOWER
FRAME LEG
ASSY.



(1)
A0626
PTO
HANDLE

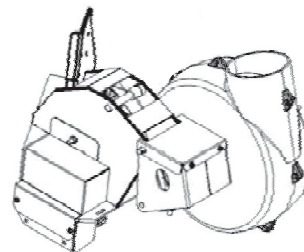

(1)
A0739
PTO
ASSEMBLY

A0683 WEIGHT KIT



(1)
HB0120
HARDWARE
BAG

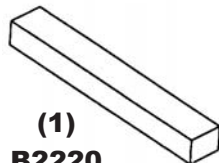

(1)
B2220
WEIGHT

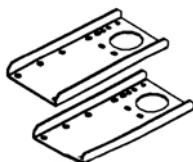

(2)
B0026
WEIGHT
BRACKET

A0908 BOOT KIT



(1)
HB0078
HARDWARE
BAG

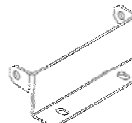

(1)
B0435
BOOT
PLATE

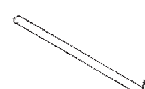

(1)
B0288
BOOT
ROD

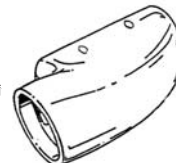

(1)
E1031
BOOT

AIR CLEANER RELOCATION FOR BOB-CAT PREDATOR PRO

Step 1: Remove air cleaner end cap and remove filter (#1).

Step 2: Remove hoses from air cleaner and intake (#2). Remove air cleaner.

Step 3: Remove (4) bolts from intake (#3). Remove intake and all existing mounting bracket hardware.

Step 4: Mount air cleaner mount plate P#(B0275) to intake using (4) original bolts (#4).

Step 5: Remount intake and air cleaner mount bracket P#(B0275) to carburetor using (4) original bolts (#5).

Step 6: Mount air cleaner mount brace P#(B0276) to manifold using (2) original bolts (#6). **Do not tighten.**

Step 7: Align holes in back of air cleaner w/ slots in air cleaner mount brace P#(B0276) and insert (2) original bolts thru back of air cleaner mount plate P#(B0275) and tighten (#7).

Step 8: Adjust air cleaner relocation assembly as needed to fit. Tighten (2) bolts located on manifold and replace hoses, filter and air filter end cap as shown in Figure 3.

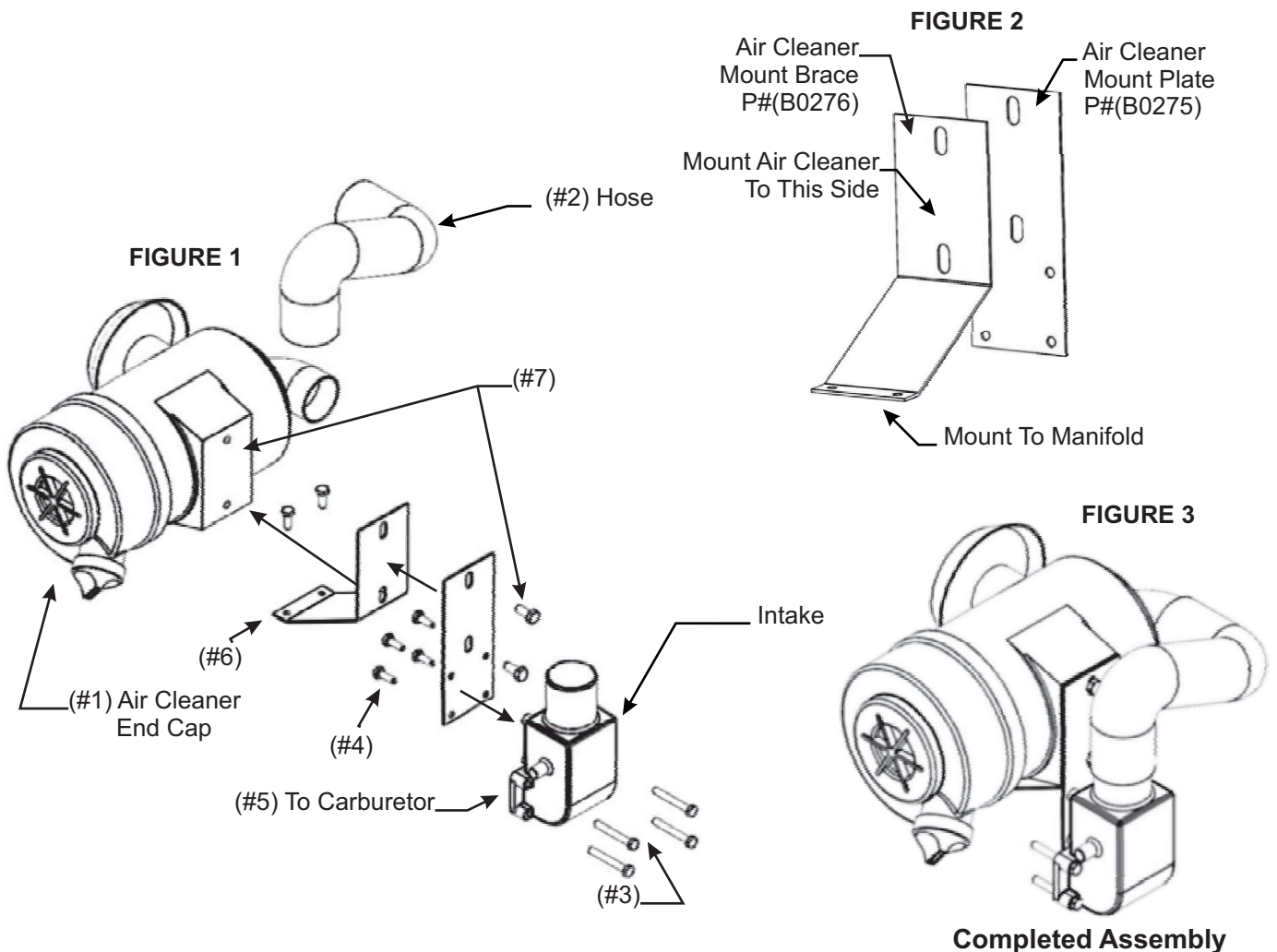

2-9 Dump Mechanism Adjustment

The linkage may be adjusted in two places, at the adjusting screw P#(K1435) and the latch assembly items. See page 9 for visual clarification. To change the door closure tightness, screw the adjusting screw in or out. To adjust the latch, change the length of the latch rod by screwing the latch adjusting ball joint in or out. The latch hook pivot should be in the middle of the slot in the latch hook pivot plate. Slide the pivot back or forth and then re-tighten.

2-10 Cam Assembly Adjustment

The cam assembly P#(A0422), which controls the blower belt tension, comes from the factory pre-adjusted. If the belt is too tight or becomes too loose, remove the hair pin clip P#(K0099) from the belt tension rod P#(K0326) and pull the "L" end of the rod out of its hole in the cam assembly. The tension rod may then be screwed out to tighten the belt or screwed in to loosen the belt. Replace the "L" end into the top hole in the cam and replace the hair pin clip. Adjust the cam stop bolt P#(K1159) to allow the cam to rotate slightly over center when the blower is engaged (Figure 2-10).

Figure 2-10

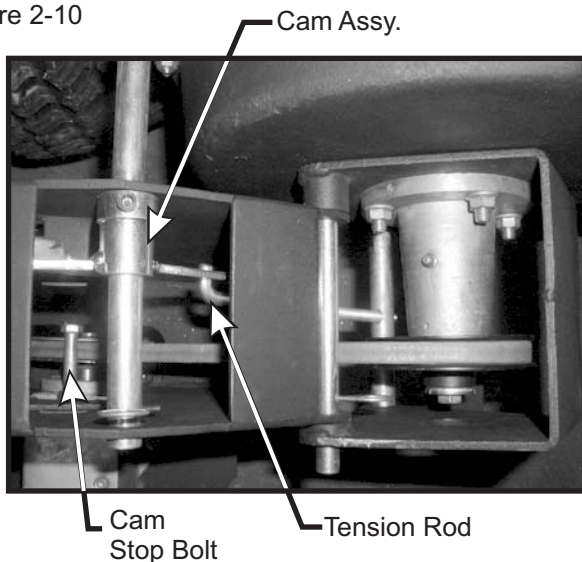

2-11 Boot Installation

To mount the boot plate P#(B0079) to the boot P#(E1030), use (2) 3/8"-16 x 1" carriage bolts P#(K1182) and (2) 3/8"-16 flange nuts P#(K1215). Make certain that when bolting the boot and boot plate together, that the head of the bolt is placed from the inside of the boot. This will prevent grass from collecting on the bolts. Hang the boot onto the mower deck, use (Figure 2-11a) for details. There are slots in the boot plate that will allow for adjustment left or right to achieve the proper fit for different size cutting decks. Once the boot is in place tighten the bolts on the mower deck's deflector shield, and rotate the deflector against the boot. The deflector will help keep the boot from moving.

Figure 2-11a

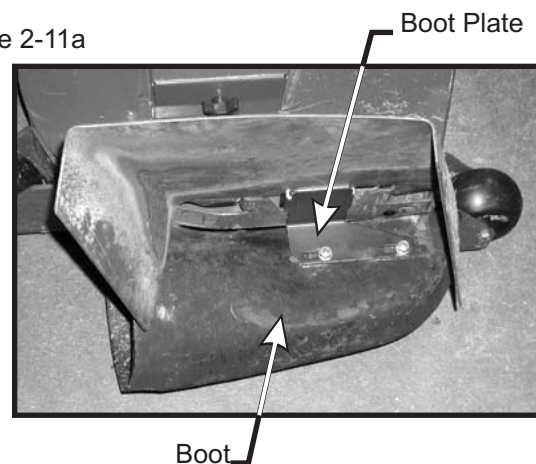

NOTE: FOR 2007 MODELS

Fasten the boot plate P#(B0435) to the boot P#(E1031) as described above. Attach the boot plate to the mower deck using the boot rod P#(B0288). Fasten the boot rod using (1) hair pin clip P#(K0099). See Figure 2-11b for reference.

Figure 2-11b

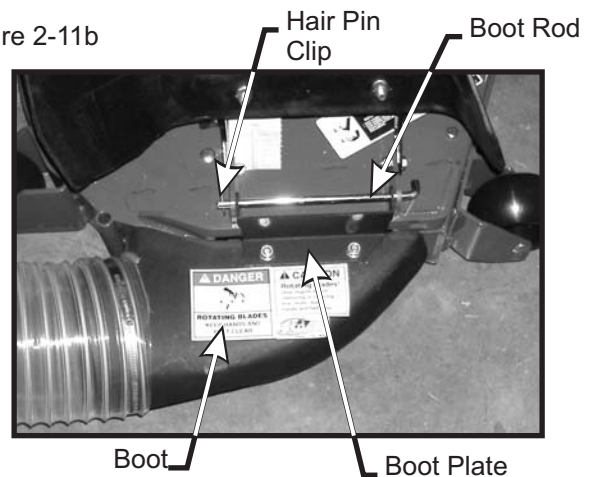

2-12 Blower Cone Installation

Thread (1) 5/16"-18 jam nut P#(K0120) onto each end of (2) 5/16"-18 x 2-1/2" HHCS P#(K0125). Now partially thread the bolts into each of the two tabs located on the blower housing. Place blower cone so the two tabs line up with the bolts then tighten completely. See Figure 2-12.

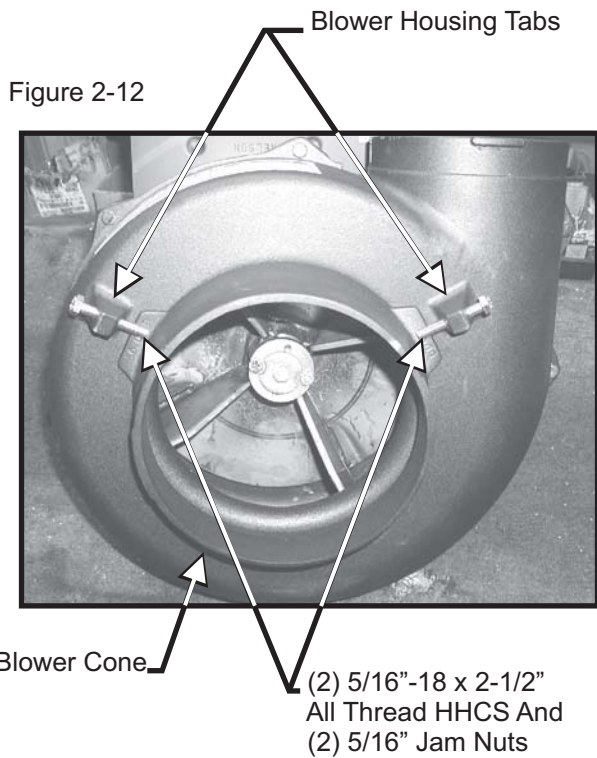

2-13 Impeller Blade Removal/Replacement

To Remove: First remove the center bolt (#1), washer (#2) and spacer (#3) from the taper-lock bushing (#5). See Figure 2-13. Next remove the (2) 1/4"-20 bolts (#4) and place them into the threaded holes of the taper-lock bushing (next to the holes they were removed from). Gradually thread each bolt evenly into the taper-lock bushing, forcing the blade to break-away from the taper-lock bushing. If the impeller will not move, hit the base of the impeller, between each vein, with a hammer, then try again.

To Replace: Place impeller blade over the engine shaft. Slide the taper-lock bushing on to the engine shaft and into the impeller blade, aligning the **non-threaded** holes of the taper-lock bushing to the threaded holes of the impeller blade. Fasten by using (2) 1/4"-20 HHCS grade #8 bolts, (1) spacer washer and (1) HHCS bolt w/ washer. Torque to the proper specifications in the torque chart on the back of this manual. Next, rotate the impeller blade to insure that the blade is clear of contact on all sides of the blower housing.

Figure 2-13

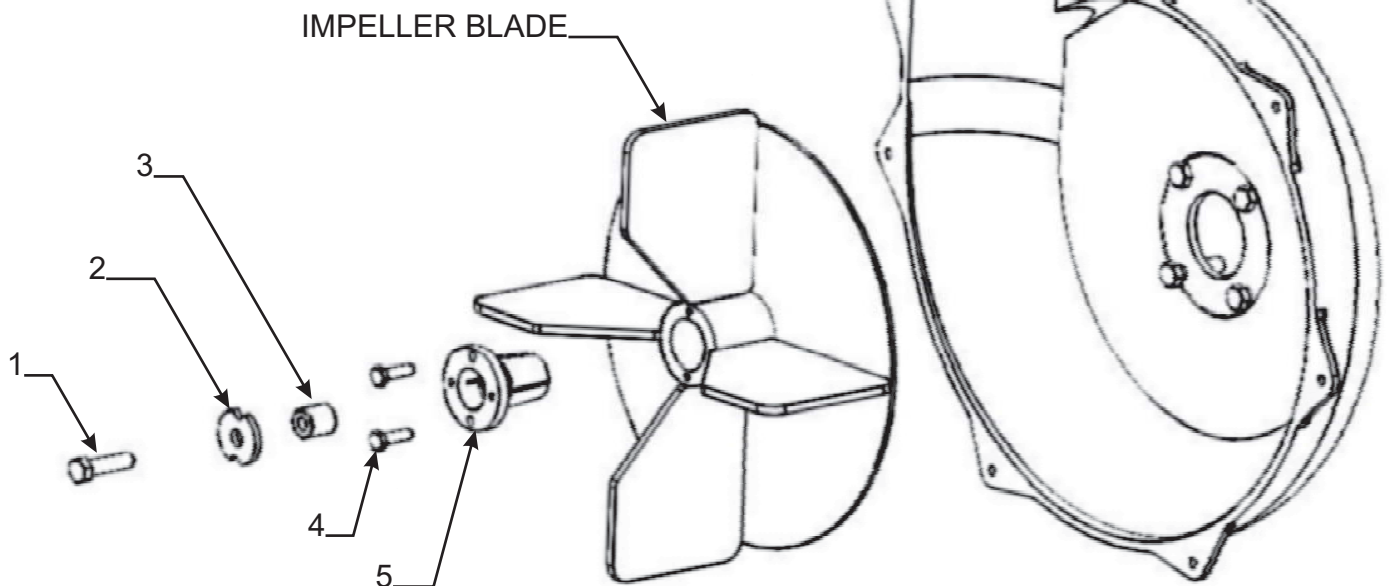

2-14 Length Of Hose Adjustment

The hoses in steps 2-15 and 2-16 must be cut to fit your machine. Follow steps 2-15 and 2-16. do not cut the hoses until you have tried to fit them on your machine. Remember that the hoses have to be long enough to adjust for the blower assembly's movement as well as allow for enough clamping surface between the inlet, blower assembly, and the deck boot.

2-15 Upper Hose Installation

Slide a 5"-6" upper hose clamp P#(J6011) onto both ends of the 6" upper hose (Figure 2-16). Then slide one end of the 6" hose onto the inlet. Make sure there is about a two-inch overlap between the hose end and the container inlet. Proceed to slide the opposite end of the 6" hose onto the outlet of the blower assembly. See (Figure 2-16) for details. Make sure both ends of the hose are clearly attached to the inlet and the blower assembly inlet. Tighten the hose clamps.

2-16 Lower Hose To Blower Cone Installation

Slide a 7"-8" hose clamp P#(J6006) over both ends of the lower hose. Then proceed to slide the lower hose onto the blower cone. Tighten the hose clamp. The assembly should look like (Figure 2-16).

Figure 2-16



2-17 Lower Hose To Boot Installation

Take the unattached end of the lower hose and slide it over the circular end of the boot. Use the lower hose clamp to secure the hose to the boot (Figure 2-17). Tip: Before securing clamp rotate hose counter-clockwise (away from yourself) approximately 1" to add in retaining boot to mower deck.

Figure 2-17

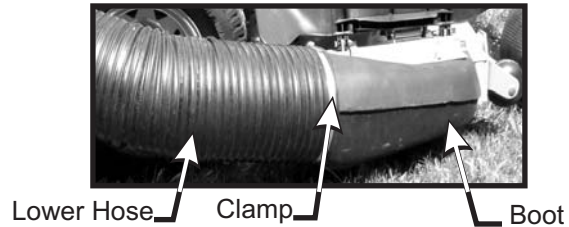

2-18 Front Weight Installation

NOTE: There is a difference between the Bobcat and Bunton front casters, use the proper bolt hole pattern picture for your mower.

Secure the weight brackets P#(B0026) to the mower by using (2) 3/8"-16 u-bolts P#(K1119) and (4) 3/8"-16 flange nuts P#(K1215). Next, secure the weight to the weight brackets by using (2) 1/2"-13 u-bolts P#(K0331) and (4) 1/2" flange nuts-13 P#(K1246). When installing the weight you should have another person help position the weight onto a floor jack. Using the floor jack will make installing the weight much easier. Tighten all nuts and bolts. Use (Figure 2-18a or 2-18b) for more detail.

Figure 2-18a Bobcat Weight Kit Bolt Pattern

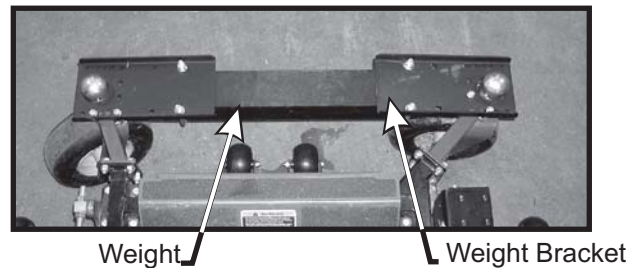
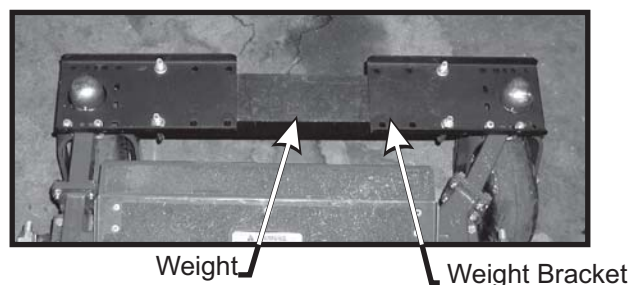

Figure 2-18b Bunton Weight Kit Bolt Pattern



SECTION III

OPERATING INSTRUCTIONS

3-1 General Safety

Only qualified people familiar with this operator's manual and the mower's operator's manual should operate this machine.

3-2 Operation And Tips On Mowing

- A. Perform BEFORE EACH USE the maintenance list in paragraph 4-1.
- B. Start mower.
- C. With the mower at high idle speed, engage the mower deck.
- D. While seated in the operator's seat, rotate the engagement handle of the collection system away from the mower. Continue to rotate the handle until it stops in an over center position. With the blower engaged, you can proceed to operate the control levers of the mower.

NOTE: If the collection system does not appear to be collecting the grass clippings; disengage the deck, and blower, engage the parking brake and turn the mower off. Proceed to section 3-3, and review the section 2-4 and 2-5, in this manual.

To obtain the maximum effectiveness from your collection system the tips listed below should be followed:

- * Watch your speed- Normal conditions will allow a speed of up to approximately 5 mph, but thick, heavy damp conditions will require reduced ground speed.
- * Mow with sharp blades- A sharp blade cuts cleaner.
- * Wet grass and leaves will decrease effectiveness and will increase horsepower requirements.
- * Mow at higher cutting heights- Remove and mulch no more than 2" of grass length with each mowing. (Experts recommend not cutting off more than 1/3 of the grass blade length at any given time.)
- * Mow twice, at different height settings, (high, then low), if grass is extra tall.
- * Remember that horsepower requirements will vary with the mowing conditions such as type and height of turf grass, moisture content, amount of leaves, whether the terrain is flat or hilly, etc.

3-3 Disengagement Of The Blower

- A. To disengage the blower, rotate the engagement handle towards the mower.

WARNING: The blower will continue to spin. DO NOT TOUCH the blower, pulleys, or the belt until the tractor is turned off. DO NOT adjust the belt tension until the mower is turned off. Refer to section 2-4 and 2-5 of the manual

3-4 Unloading The Collection System

NOTE: Press the tab, located behind the operator's left side, downward to feel if the collection system is full. If the container is full there will be resistance when depressing the tab.

- A. Stop the forward movement of the mower.
- B. Disengage the mower deck.
- C. Disengage the blower.
- D. Verify that the dump area is clear.
- E. Push the dump handle, on the left of the operator, away from the unit. While holding the handle pushed away, move the handle upward. The container door will swing upward and the container will rotate downward. The container will release its contents.
- F. Once the contents of the container have fallen out, the container is ready to move back into its normal operating position. With the handle in the 'away' position, pull the handle downward until it stops. Move the handle towards the center of the mower. This motion will allow the latch to lock back into collection position.

NOTE: If you do not hold the handle away from the mower as you pull the handle downward, the latch will not lock and the container can unexpectedly release the contents collected.

SECTION IV MAINTENANCE

4-1 Maintenance Checklist

Before each use:

1. Check blades and spindles to be sure that no foreign objects, such as wire or steel strapping bands, are wrapped around them.
2. Inspect blades for wear. Replace if necessary. If it is necessary to sharpen the blades, remove the blades from the spindles before sharpening. DO NOT sharpen blades while still attached to the mower.
3. Make sure all shields are in place and in good condition. Repair or replace any missing or damaged shields.
4. Perform lubrication per paragraph 4-2.
5. Listen for abnormal sounds, which might indicate loose parts, damaged bearings, or other damage. Correct any deficiency before continuing operation.
6. With the engine off, engage the blower assembly. Check the belt tension and inspect the pulley belt for cracks or tears.
7. Check for wear or deterioration of the upper or lower hoses. If there are any portions of the hose that have been torn or worn through, replace with genuine PECO parts.

After Each Use:

1. Clean all debris from machine especially from the container, underneath the belt shields, and

- safety decals. Replace any missing or illegible decals.
2. Inspect the unit for worn or damaged components. Repair or replace before the next use. Any replacement component installed during repair shall include the component's current safety decal specified by the manufacturers to be affixed to the component.
 3. Check belt for proper tension.

4-2 Lubrication

NOTE: Use only white lithium based grease for lubrication of the shaft on the blower assembly.

1. On initial use: Grease the fitting on the blower shaft.
2. Every 25 hours of use: Re-grease the grease fitting.
3. Every 200 hours of use: Check oil levels in gear box. Oil in gear box should cover the gears. If not, fill using an EP90 weight oil. 6oz. will fill the gear box from empty.

SECTION V PARTS AND SERVICE

5-1 Parts And Service Information

PECO collection system owners should record the name and telephone number of their Service Center. Your Service Center will be happy to supply replacement parts, accessories, and do any service or repairs to your collection system. If for any reason your Service Center is unable to service your collection system or supply replacement parts, contact PECO and include the following information on the chart below.

THE SERIAL NUMBER PLATE IS LOCATED ON THE ALUMINUM BOX NEAR THE DUMP HANDLE

| | |
|------------------------------------|--|
| PECO | |
| OUTDOOR POWER EQUIPMENT | |
| Model Number | <input style="width: 95%;" type="text"/> |
| Serial Number | <input style="width: 95%;" type="text"/> |
| Arden, North Carolina 28704 | |

WRITE THE MODEL AND SERIAL NUMBER IN THE BOX ABOVE FOR FUTURE REFERENCE.

Unit Model Number: _____

Unit Engine Size: _____

Unit Serial Number: _____

Date of purchase: ____/____/____

Dealer/Distributor Name: _____

Address: _____ **State:** _____ **Zip:** _____

Phone Number: _____

Address: PECO Inc.
P.O. Box 1197
Arden, NC 28704
Phone #: (828) 684-1234 or Toll Free: (800) 438-5823
Email: peco@lawnvac.com

SAFETY DECALS

To promote safe operation, PECO supplies safety decals on all products manufactured. Damage can occur to safety decals either through shipment, use or reconditioning. Contact your local Service Center for replacement decals.



Part #: R4027

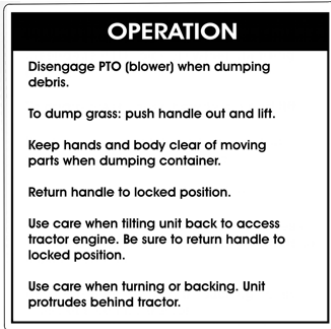

Part #: R1049



Part #: R1054



Part #: R1052



Part #:R4008



Part #: R1069

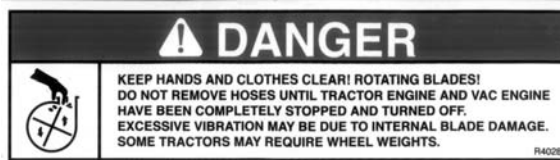

Part #: R4028



Part #: R1053



Part #: R1057



Part #: R1055



Part #:R4015



Part #: R4037



Part #:R1083



Part #: R1065



Part #:R1051



Part #: R1070

TORQUE SPECIFICATIONS

Proper torque for American fasteners used on **Peco** equipment.
Recommended Torque in Foot Pounds (Newton Meters).*

AMERICAN Bolt Head Markings

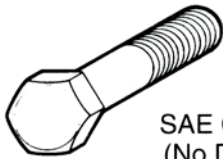

SAE Grade 2
(No Dashes)

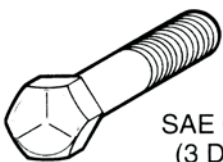

SAE Grade 5
(3 Dashes)

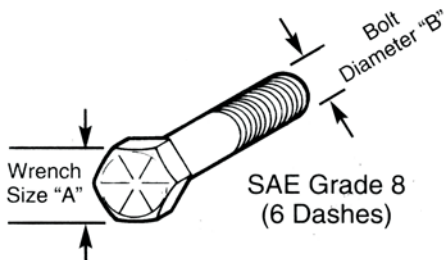

SAE Grade 8
(6 Dashes)

| WRENCH SIZE (IN.) "A" | BOLT DIAMETER (IN.) "B" AND THREAD SIZE | SAE GRADE 2 | SAE GRADE 5 | SAE GRADE 8 |
|-----------------------|---|-------------|-------------|-------------|
| 7/16 | 1/4 - 20 UNC | 6 (7) | 8 (11) | 12 (16) |
| 7/16 | 1/4 - 28 UNF | 6 (8) | 10 (13) | 14 (18) |
| 1/2 | 5/16 - 18 UNC | 11 (15) | 17 (23) | 25 (33) |
| 1/2 | 5/16 - 24 UNF | 13 (17) | 19 (26) | 27 (37) |
| 9/16 | 3/8 - 16 UNC | 20 (27) | 31 (42) | 44 (60) |
| 9/16 | 3/8 - 24 UNF | 23 (31) | 35 (47) | 49 (66) |
| 5/8 | 7/16 - 14 UNC | 32 (43) | 49 (66) | 70 (95) |
| 5/8 | 7/16 - 20 UNF | 36 (49) | 55 (75) | 78 (106) |
| 3/4 | 1/2 - 13 UNC | 49 (66) | 76 (103) | 106 (144) |
| 3/4 | 1/2 - 20 UNF | 55 (75) | 85 (115) | 120 (163) |
| 7/8 | 9/16 - 12 UNC | 70 (95) | 109 (148) | 153 (207) |
| 7/8 | 9/16 - 18 UNF | 79 (107) | 122 (165) | 172 (233) |
| 15/16 | 5/8 - 11 UNC | 97 (131) | 150 (203) | 212 (287) |
| 15/16 | 5/8 - 18 UNF | 110 (149) | 170 (230) | 240 (325) |
| 1-1/8 | 3/4 - 10 UNC | 144 (195) | 266 (360) | 376 (509) |
| 1-1/8 | 3/4 - 16 UNF | 192 (260) | 297 (402) | 420 (569) |
| 1-5/16 | 7/8 - 9 UNC | 166 (225) | 430 (583) | 606 (821) |
| 1-5/16 | 7/8 - 14 UNF | 184 (249) | 474 (642) | 668 (905) |
| 1-1/2 | 1 - 8 UNC | 250 (339) | 644 (873) | 909 (1232) |
| 1-1/2 | 1 - 12 UNF | 274 (371) | 705 (955) | 995 (1348) |
| 1-1/2 | 1 - 14 UNF | 280 (379) | 721 (977) | 1019 (1381) |
| 1-11/16 | 1-1/8 - 7 UNC | 354 (480) | 795 (1077) | 1288(1745) |
| 1-11/16 | 1-1/8 - 12 UNF | 397 (538) | 890 (1206) | 1444 (1957) |
| 1-7/8 | 1-1/4 - 7 UNC | 500 (678) | 1120 (1518) | 1817 (2462) |
| 1-7/8 | 1-1/4 - 12 UNF | 553 (749) | 1241 (1682) | 2013 (2728) |
| 2-1/16 | 1-3/8 - 6 UNC | 655 (887) | 1470 (1992) | 2382 (3228) |
| 2-1/16 | 1-3/8 - 12 UNF | 746 (1011) | 1672 (2266) | 2712 (3675) |
| 2-1/4 | 1-1/2 - 6 UNC | 870 (1179) | 1950 (2642) | 3161 (4283) |
| 2-1/4 | 1-1/2 - 12 UNF | 979 (1327) | 2194 (2973) | 3557 (4820) |

METRIC

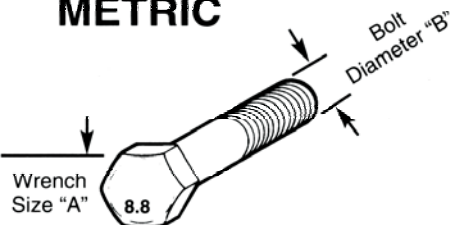

Numbers appearing on bolt heads indicate ASTM class.

Proper torque for metric fasteners used on **Peco** equipment.
Recommended torque in foot pounds (newton Meters).*

| WRENCH SIZE (mm) "A" | BOLT DIA. (mm) "B" | ASTM 4.6 | ASTM 8.8 | ASTM 9.8 | ASTM 10.9 |
|----------------------|--------------------|-----------|-------------|-----------|-------------|
| 8 | 5 | 1.8 (2.4) | | 5.1 (6.9) | 6.5 (8.8) |
| 10 | 6 | 3 (4) | | 8.7 (12) | 11.1 (15) |
| 13 | 8 | 7.3 (10) | | 21.1 (29) | 27 (37) |
| 16 | 10 | 14.5 (20) | | 42 (57) | 53 (72) |
| 18 | 12 | 25 (34) | 74 (100) | 73 (99) | 93 (126) |
| 21 | 14 | 40 (54) | 118 (160) | 116 (157) | 148 (201) |
| 24 | 16 | 62 (84) | 167 (226) | 181 (245) | 230 (312) |
| 30 | 20 | 122 (165) | 325 (440) | | 449 (608) |
| 33 | 22 | | 443 (600) | | 611 (828) |
| 36 | 24 | 211 (286) | 563 (763) | | 778 (1054) |
| 41 | 27 | | 821 (1112) | | 1138 (1542) |
| 46 | 30 | 418 (566) | 1119 (1516) | | 1547 (2096) |

*Use 75% of the specified torque value for plated fasteners. Use 85% of the specified torque values for lubricated fasteners.

DRAWING IS FULL SCALE.
MAY BE USED AS A TEMPLATE.

CUT ALONG THIS LINE

DRILL TEMPLATE
FOR THE TEXTRON
REAR CHASSIS

$\varnothing 0.406$
USE A
13/32" DRILL

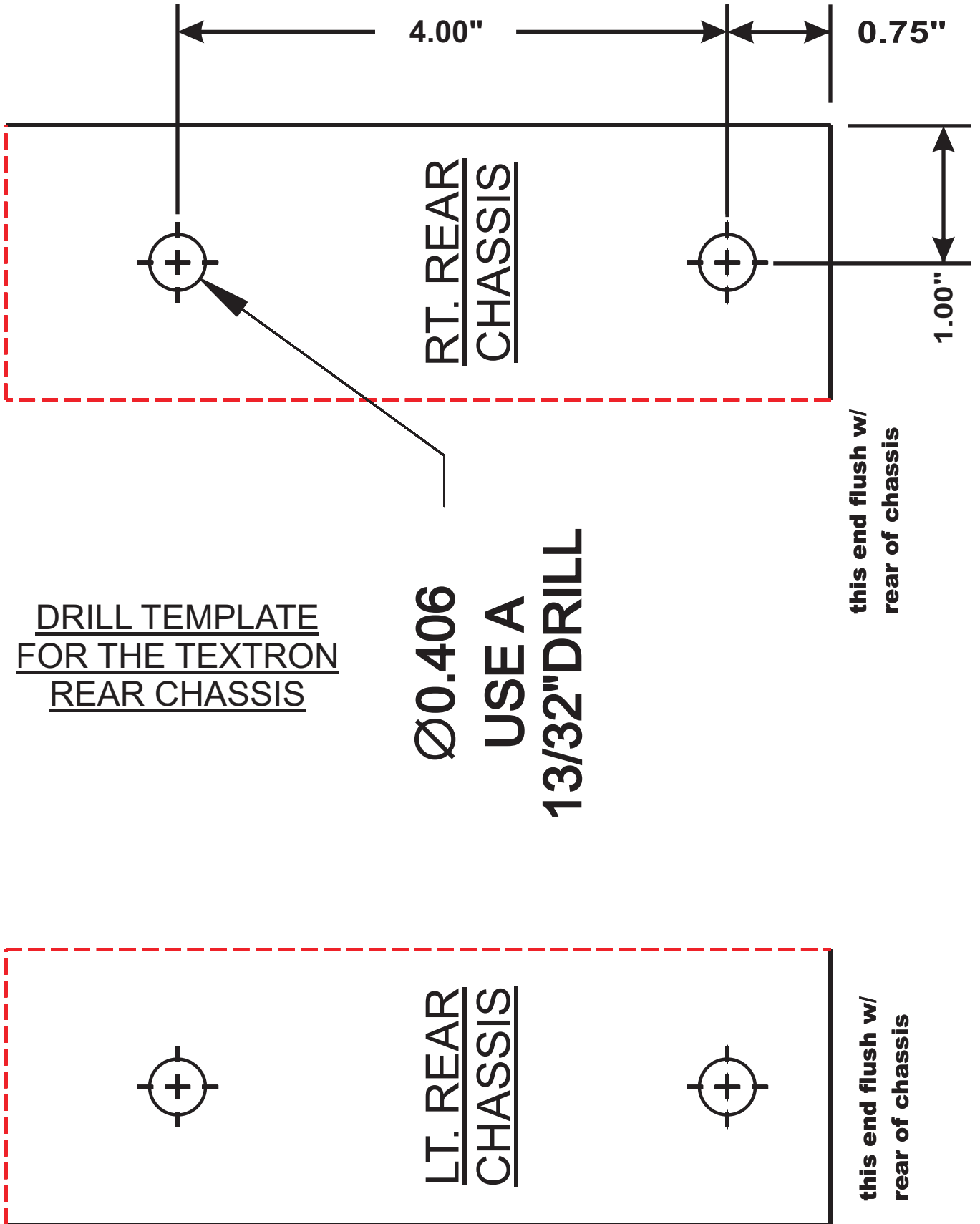

this end flush w/
rear of chassis

this end flush w/
rear of chassis



**P.O. BOX 1197
ARDEN, NORTH CAROLINA 28704
(800) 438-5823 OR (828) 684-1234 FAX: (828) 684-0858
EMAIL: peco@lawnvac.com
WEBSITE: www.lawnvac.com**