

MODEL#: 06031505

MOWER NAME: JOHN DEERE

MOWER MODEL: Z900 SERIES

MOWER DECK SIZE: 54" 7-IRON

VAC NAME: 15 CUBIC FOOT PRO BAGGER

ENG: 900 SER. BR (9.00 GROSS TORQUE / 205 cc)

MANUAL: Q0404



FOR YEAR: 2009 - 2011

REVISED: 5/10/2012

A1774 UNIT ASSEMBLY

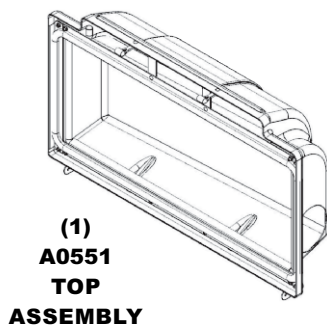

(1)
A0551
TOP
ASSEMBLY

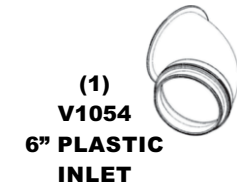

(1)
V1054
6" PLASTIC
INLET



(1)
F0004
7" x 38"
LOWER
HOSE



(1)
F0001
6" x 30"
UPPER
HOSE



(2)
J0060
6" HOSE
CLAMPS



(2)
J0070
7" HOSE
CLAMPS



(1)
E6004
7" BLOWER
CONE

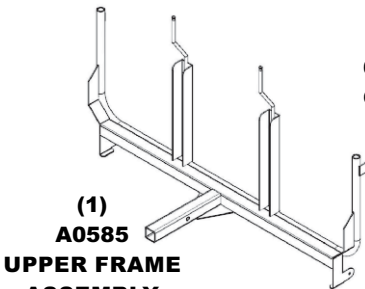

(1)
A0585
UPPER FRAME
ASSEMBLY

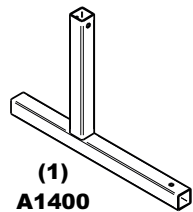

(1)
A1400
LWR. MNT.
TUBE ASSY.

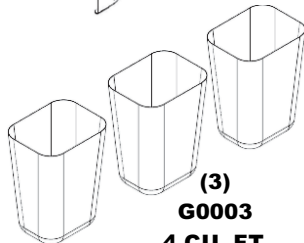

(3)
G0003
4 CU. FT.
COLLECTION
BAGS

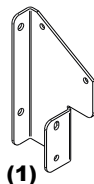

(1)
B0597
LT. LWR.
MAIN FRAME
LEG

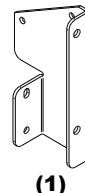

(1)
B0598
RT. LWR.
MAIN FRAME
LEG

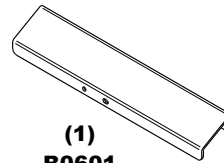

(1)
B0601
MNT. TUBE
SUPPORT BRKT.

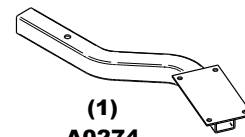

(1)
A0274
ENGINE MNT.
ARM ASSY.



(1)
HB0414
HARDWARE
BAG

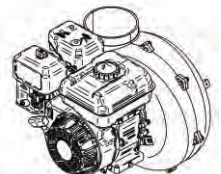

(1)
ENGINE/
BLOWER/
BLADE ASSY.

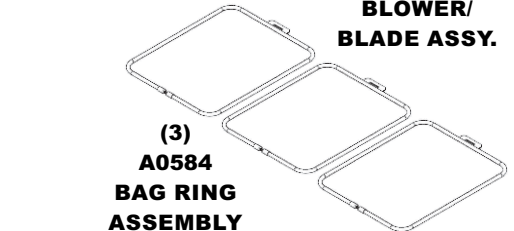

(3)
A0584
BAG RING
ASSEMBLY

A1768 - WEIGHT KIT



(1)
HB0413
HARDWARE
BAG

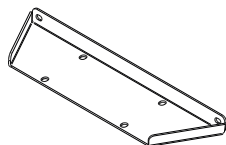

(1)
B0600
WEIGHT
BRACKET

(1)
B0035
WEIGHT

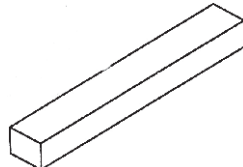

A1771 - 54" BOOT KIT



(1)
HB0412
HARDWARE
BAG

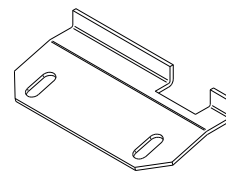

(1)
B0001
BOOT
PLATE

(1)
E1103
BOOT

