

# MODEL#: 06031503

MOWER NAME: JOHN DEERE

MOWER MODEL: Z900 SERIES

MOWER DECK SIZE: 60" 7-IRON

VAC NAME: 15 CUBIC FOOT PRO BAGGER

ENG: 900 SER. BR (9.00 GROSS TORQUE / 205 cc)

MANUAL: Q0404



FOR YEAR: 2009 - 2011

REVISED: 5/10/2012

## A1776 UNIT ASSEMBLY

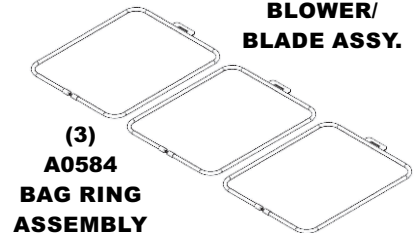
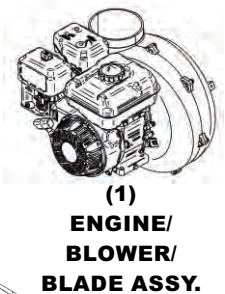
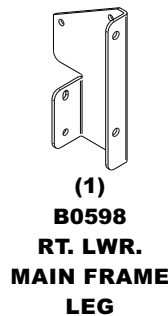
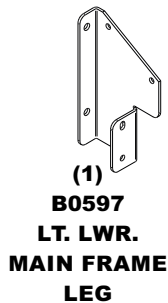
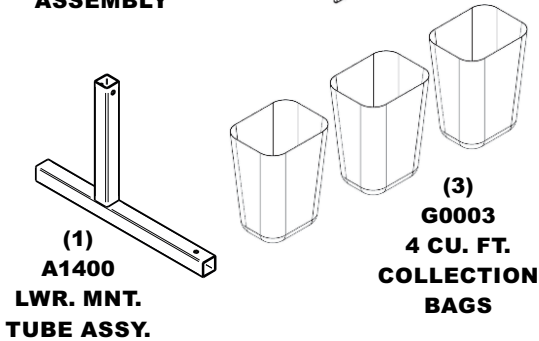
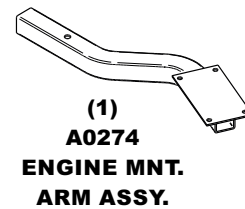
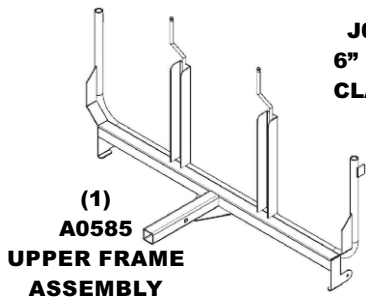
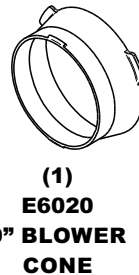
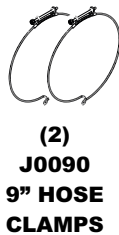
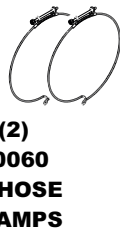
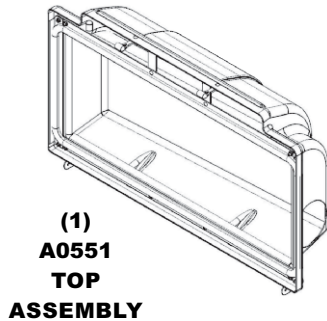

## A1768 - WEIGHT KIT

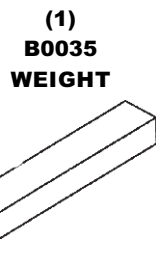
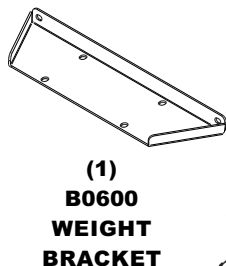
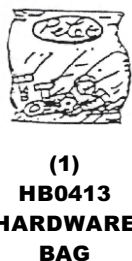

## A1767 - 60" BOOT KIT

