

MODEL#: 35031501

MOWER NAME: EXMARK 2009

MOWER MODEL: NEXT GENERATION LAZER Z

MOWER DECK SIZE: 48" 52" 60" & 72"

VAC NAME: 15 CUBIC FOOT PRO BAGGER

ENG: 900 SER. BR (9.00 GROSS TORQUE / 205 cc)

MANUAL: Q0386



FOR YEAR: 2009 - 2010

REVISED: 5/10/2012

A1707 UNIT ASSEMBLY

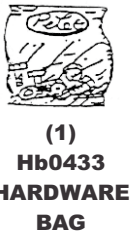
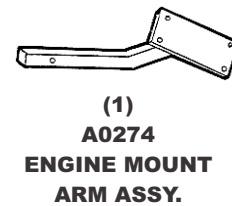
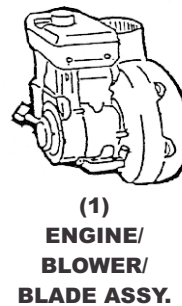
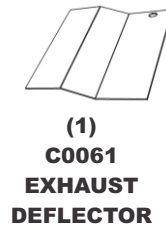
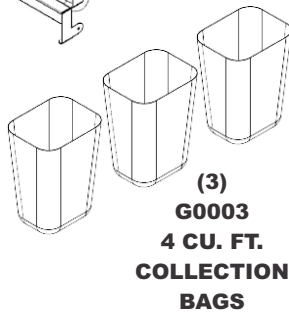
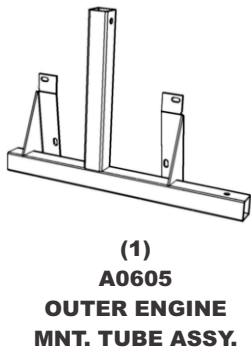
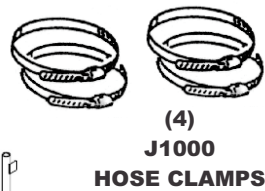
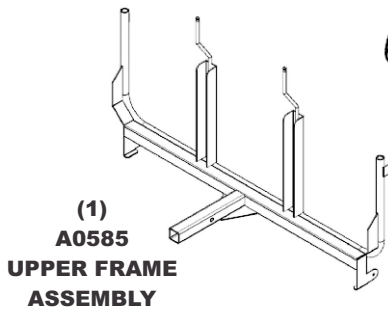
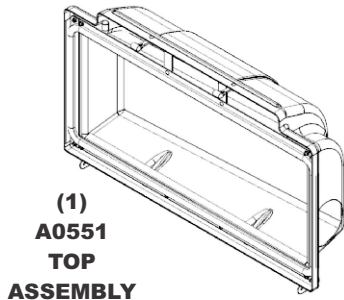

(1) B0529 LEFT &
(1) B0528 RIGHT
LOWER MAIN
FRAME LEGS

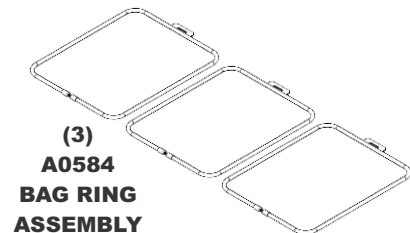
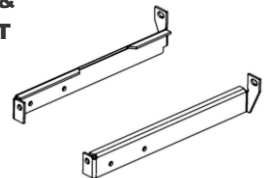

A0665 - WEIGHT KIT

(2)
B0026
WEIGHT
BRACKETS

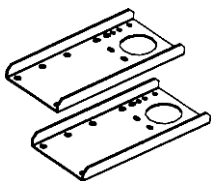

(1)
HB0370
HARDWARE
BAG



(1)
B2220
WEIGHT

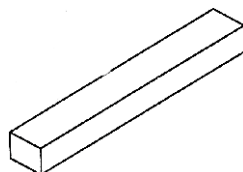

A0641 - 60" BOOT KIT

(1)
HB0207
HARDWARE
BAG



(2)
B0538
BOOT PLATE

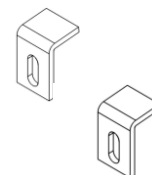

(1)
E1039
BOOT

