

MODEL#: 35031505

MOWER NAME: EXMARK 2009

MOWER MODEL: NEXT GENERATION LAZER Z

MOWER DECK SIZE: 48" 52" 60" & 72"

VAC NAME: 15 CUBIC FOOT PRO BAGGER

6.5 BRIGGS AND STRATTON VANGUARD

MANUAL: #Q0386



FOR YEAR: 2009 - 2010

REVISED: 12/20/11

A1708 UNIT ASSEMBLY

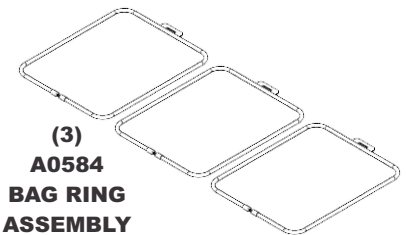
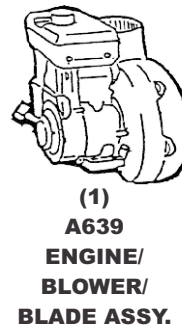
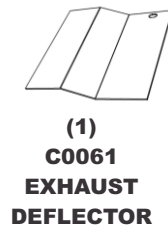
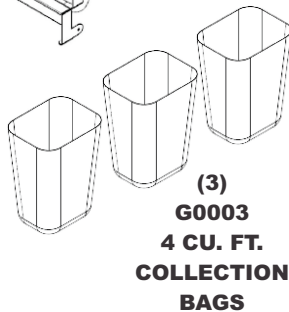
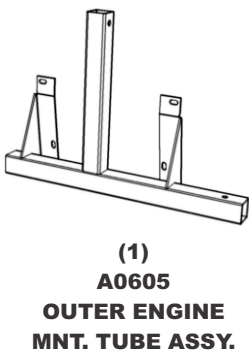
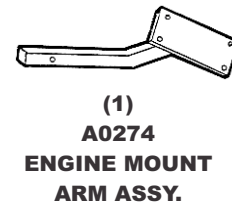
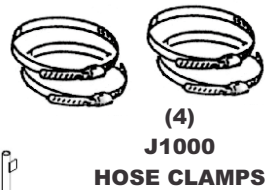
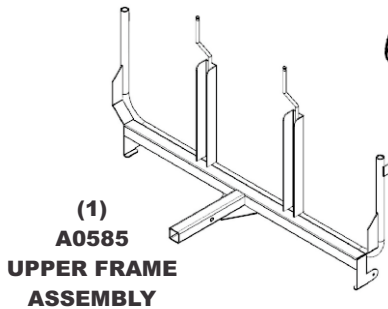
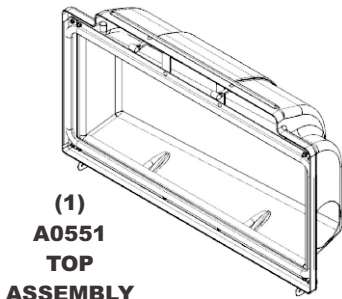

A0665 - WEIGHT KIT

(2)
B0026
WEIGHT
BRACKETS

(1)
HB0370
HARDWARE
BAG

(1)
B2220
WEIGHT

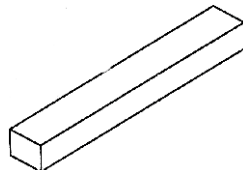
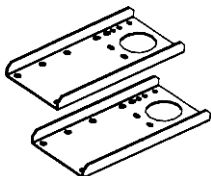

A0641 - 60" BOOT KIT

(1)
HB0207
HARDWARE
BAG

(1)
B0538
BOOT PLATE

(1)
E1039
BOOT

