

# MODEL#: 21031207

MOWER NAME: CUB CADET

MOWER MODEL: TANK

MOWER DECK SIZE: 48" 54" & 60"

VAC NAME: 12 CUBIC FOOT PRO BAGGER

6.5 BRIGGS AND STRATTON VANGUARD

BOM0326



FOR YEAR: 2006 - 2008

REVISED: 12/20/11

## A0926 UNIT ASSEMBLY

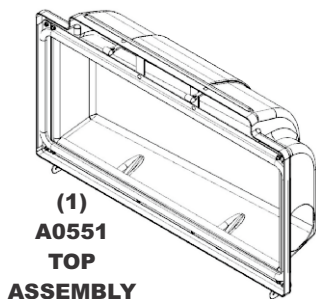

(1)  
A0551  
TOP  
ASSEMBLY



(1)  
V1054  
6" PLASTIC  
INLET



(1)  
7" x 35"  
LOWER  
HOSE



(1)  
6" x 21"  
UPPER  
HOSE



(4)  
J1000  
HOSE  
CLAMPS

## A0619 THROTTLE KIT

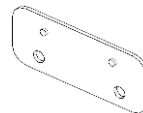

(1)  
A0666  
THROTTLE  
MNT. PL.  
ASSY.



(1)  
A0060  
70" THROTTLE  
KIT  
FOR (5.5 & 6.5HP)



(1)  
HB0249  
HARDWARE  
BAG

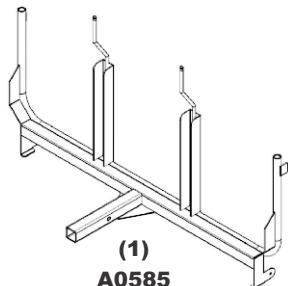

(1)  
A0585  
UPPER FRAME  
ASSEMBLY

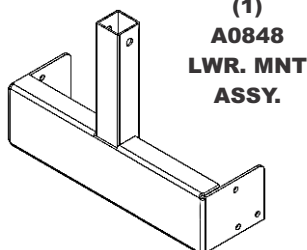

(1)  
A0848  
LWR. MNT.  
ASSY.

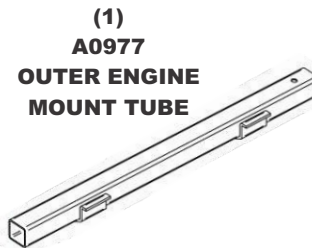

(1)  
A0977  
OUTER ENGINE  
MOUNT TUBE



(1)  
HB0343  
HARDWARE  
BAG

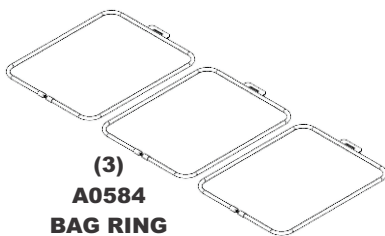

(3)  
A0584  
BAG RING  
ASSEMBLY

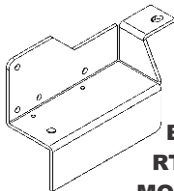

(1)  
B0396  
RT. LWR.  
MOUNT PL.

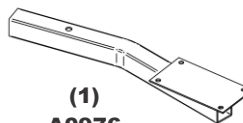

(1)  
A0976  
ENGINE MNT.  
ARM ASSY.

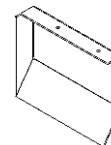

(1)  
C0058  
EXHAUST  
DEFLECTOR

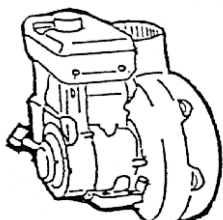

(1)  
A639  
ENGINE/  
BLOWER/  
BLADE ASSY.

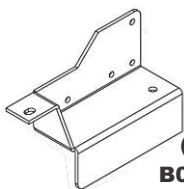

(1)  
B0395  
LT. LWR.  
MOUNT PL.



(1)  
E6004  
7" BLOWER  
CONE

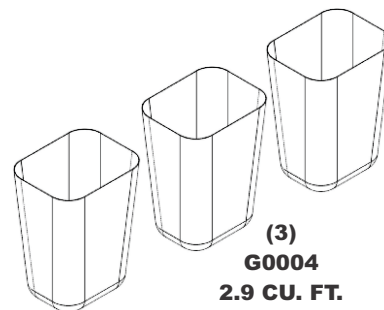

(3)  
G0004  
2.9 CU. FT.  
COLLECTION  
BAGS

## A0689 - WEIGHT KIT

(2)  
B0026  
WEIGHT  
BRACKETS

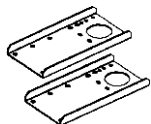

(1)  
HB0314  
HARDWARE  
BAG



(1)  
B2220  
WEIGHT

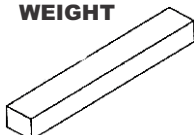

## A0690 - BOOT KIT



(1)  
HB0078  
HARDWARE  
BAG

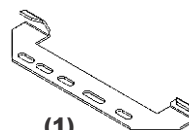

(1)  
B2555  
BOOT  
PLATE

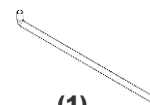

(1)  
B4331  
BOOT ROD

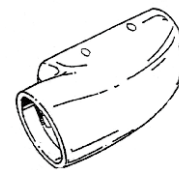

(1)  
E1031  
BOOT