

# MODEL#: 37621209

MOWER NAME: SCAG TIGER CUB

MOWER MODEL: STC48-19KA, STC48A-19KA, STC48-20CV, STC48-21KA, & STC48A-21KA

MOWER DECK SIZE: 48" REG. & ADVANTAGE DECKS

VAC NAME: 12 CUBIC FOOT BOX

ENG: 900 SER. BR (9.00 GROSS TORQUE / 205 cc)

NOTE:



FOR YEAR: 2001

REVISED: 5/9/2012

WAS  
376212-TC-01

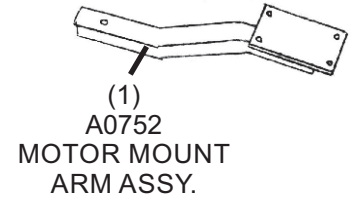
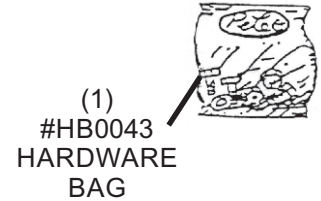
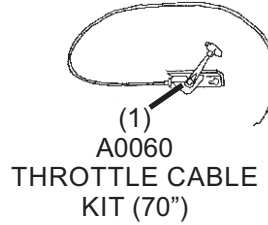
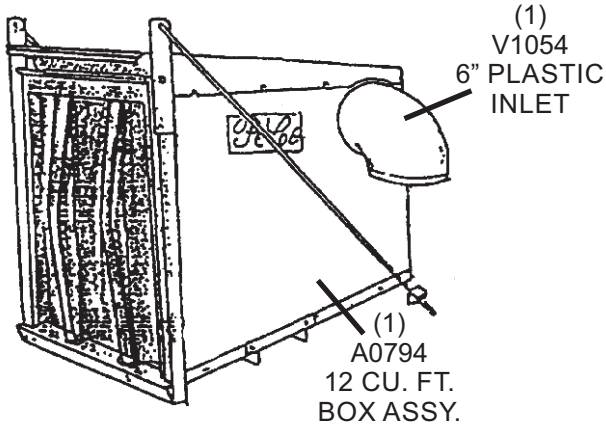

(1)  
6" x 29"  
UPPER  
HOSE

(1)  
7" x 42"  
LOWER  
HOSE

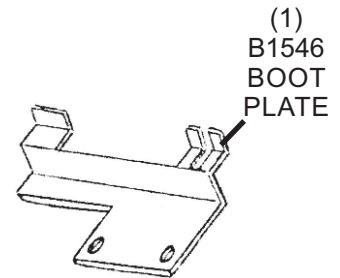
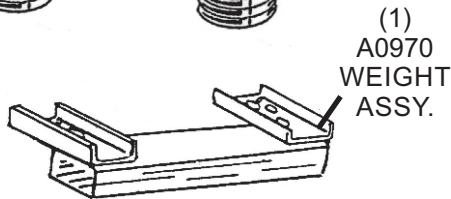
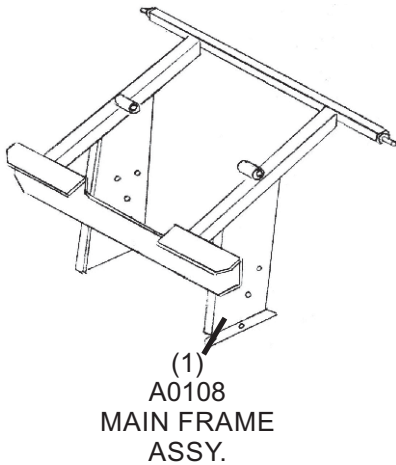
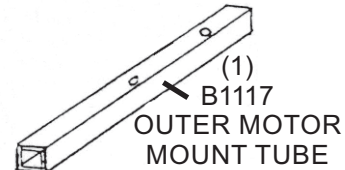
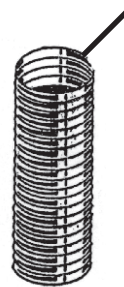
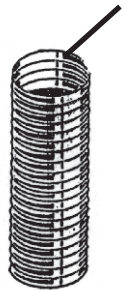

(1)  
ENGINE/  
BLOWER/  
BLADE ASSY.

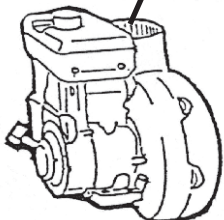

(1)  
E6004  
7" BLOWER  
CONE

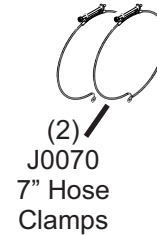
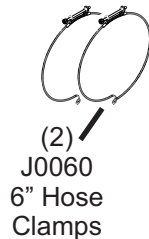
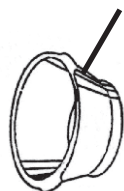

(1)  
E1117  
BOOT

