

MODEL#: 38621228

MOWER NAME: DIXIE CHOPPER

MOWER MODEL: XF2500

MOWER DECK SIZE: 60"

VAC NAME: 12 CUBIC FOOT BOX

6.5HP BRIGGS AND STRATTON VANGUARD

NOTE:



FOR YEAR: 2001 & BELOW

REVISED: 12/19/11

WAS

386212XF2500-01

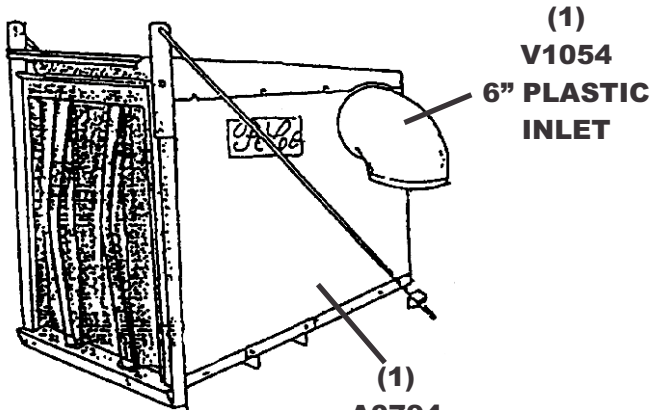

(1)

V1054

6" PLASTIC
INLET

(1)

A0794
12 CU. FT.
BOX ASSY.

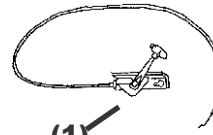

(1)

A0060
70" LONG
THROTTLE KIT FOR
(5.5 & 6.5HP)



(1)

#HB0061
HARDWARE
BAG

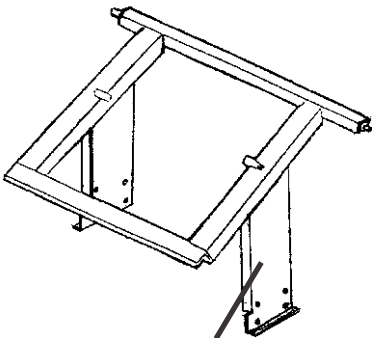

(1)

A0101
MAIN FRAME
ASSY.

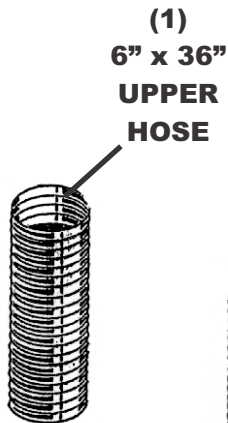

(1)

6" x 36"
UPPER
HOSE

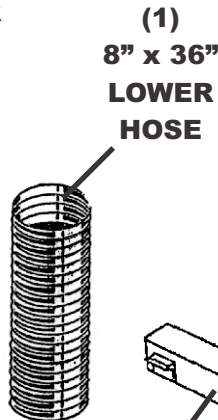

(1)

8" x 36"
LOWER
HOSE

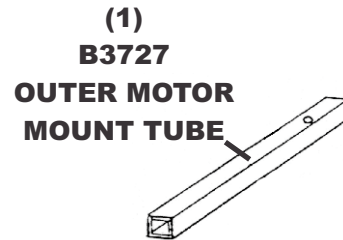

(1)

B3727
OUTER MOTOR
MOUNT TUBE

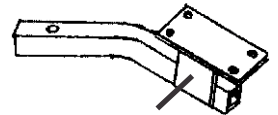

(1)

A0100
MOTOR MOUNT
ARM ASSY.

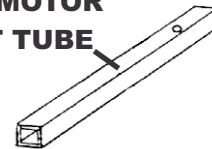

(1)

B3576
BOOT PLATE

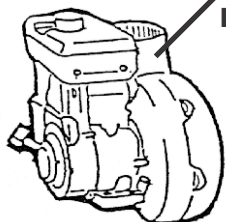

(1)

A639
ENGINE/
BLOWER/
BLADE ASSY.



(1)

E6009
8" BLOWER
CONE

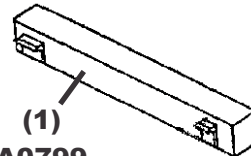

(1)

A0799
WEIGHT ASSY.

(2)

J6006
7" - 8"



HOSE CLAMPS

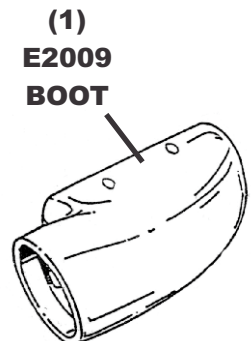

(1)

E2009
BOOT