

# MODEL#: 37621225

**MOWER NAME: SCAG TIGER CUB**

**MOWER MODEL:** STC48-19KA, STC48A-19KA, STC48-20CV, STC48-21KA, & STC48A-21KA

**MOWER DECK SIZE: 48" REG. & ADVANTAGE DECKS**

**VAC NAME: 12 CUBIC FOOT BOX**

**6.5 BRIGGS AND STRATTON VANGUARD**

**NOTE:**



**FOR YEAR: 2001**

**REVISED: 12/20/11**

**WAS  
376212-TC-01**

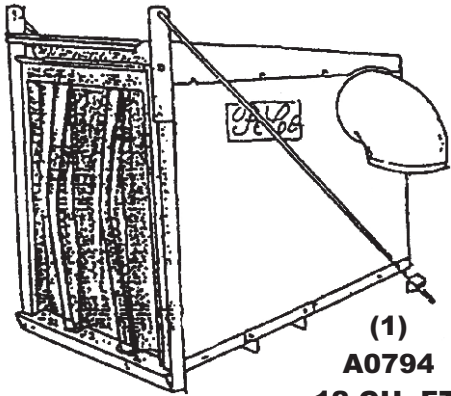

(1)  
**A0794  
12 CU. FT.  
BOX ASSY.**

(1)  
**V1054  
6"  
PLASTIC  
INLET**

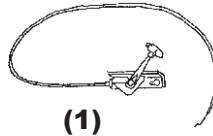

(1)  
**A0060  
70" THROTTLE  
CABLE KIT  
FOR(5.5 & 6.5HP)**



(1)  
**#HB0043  
HARDWARE  
BAG**

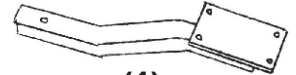

(1)  
**A0752  
MOTOR MOUNT  
ARM ASSY.**

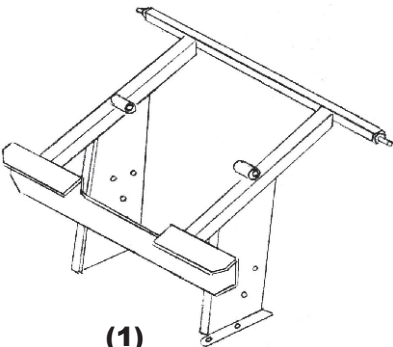

(1)  
**A0108  
MAIN FRAME  
ASSY.**

(1)  
**6" x 29"  
UPPER  
HOSE**



(1)  
**7" x 42"  
LOWER  
HOSE**

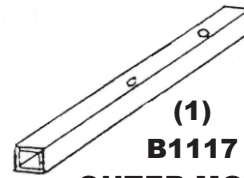

(1)  
**B1117  
OUTER MOTOR  
MOUNT TUBE**

(1)  
**A0970  
WEIGHT  
ASSY.**

(1)  
**B1546  
BOOT  
PLATE**

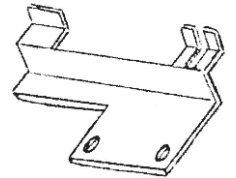
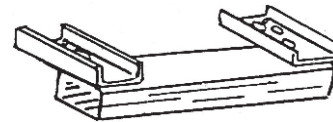

(1)  
**A639  
ENGINE/  
BLOWER/  
BLADE ASSY.**

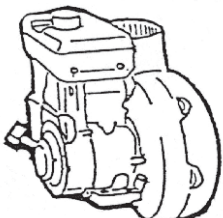

(1)  
**E6004  
7" BLOWER  
CONE**



(2)  
**J0060  
6" Hose  
Clamps**



(2)  
**J0070  
7" Hose  
Clamps**

(1)  
**E1117  
BOOT**

