

MODEL#: 37621222

MOWER NAME: SCAG TURF TIGER

MOWER MODEL: STT52A-22KA, STT52A-23CH, STT52A-25CH

MOWER DECK SIZE: 52" ADVANTAGE DECK

VAC NAME: 12 CUBIC FOOT BOX



6.5 BRIGGS AND STRATTON VANGUARD

NOTE:



FOR YEAR:2001 & BELOW

REVISED: 12/20/11

WAS

376212-01

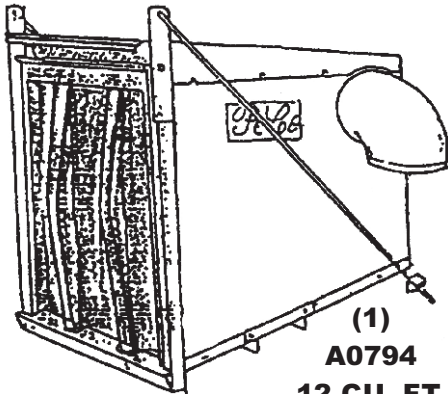

(1)
A0794
12 CU. FT.
BOX ASSY.

(1)
V1054
6"
PLASTIC
INLET

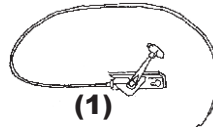

(1)
A0060
70" THROTTLE KIT
FOR (5.5 & 6.5HP)



(1)
#A08217
HARDWARE
BAG

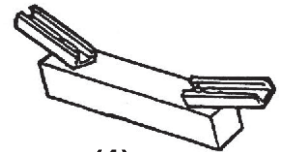

(1)
A0931
WEIGHT
ASSY.

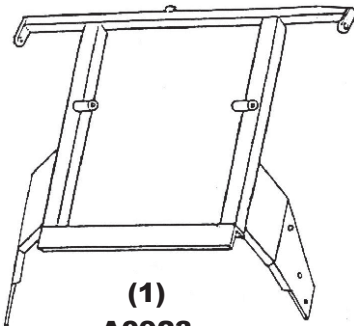

(1)
A0923
MAIN FRAME
ASSY.

(1)
6" x 39"
UPPER
HOSE



(1)
7" x 42"
LOWER
HOSE

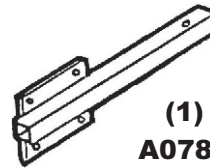

(1)
A0785
OUTER MOTOR
MOUNT ASSY.

(1)
B1546
BOOT
PLATE

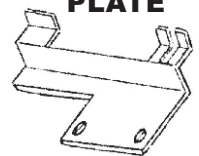

(1)
A639
ENGINE/
BLOWER/
BLADE ASSY.

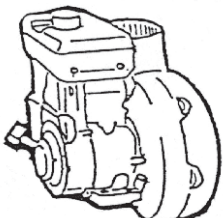

(1)
E6004
7" BLOWER
CONE



(2)
J0060
6" Hose
Clamps



(2)
J0070
7" Hose
Clamps

(1)
E1031
BOOT

