

MODEL#: 35621223

MOWER NAME: EXMARK LAZER Z HP

MOWER MODEL: LZHP48 & LZHP52

MOWER DECK SIZE: (48" & 52" DECKS)

VAC NAME: 12 CUBIC FOOT BOX

6.5HP BRIGGS AND STRATTON VANGUARD

NOTE:



FOR YEAR: 2001-1999

REVISED: 12/19/11

**WAS
356212-HP-01**

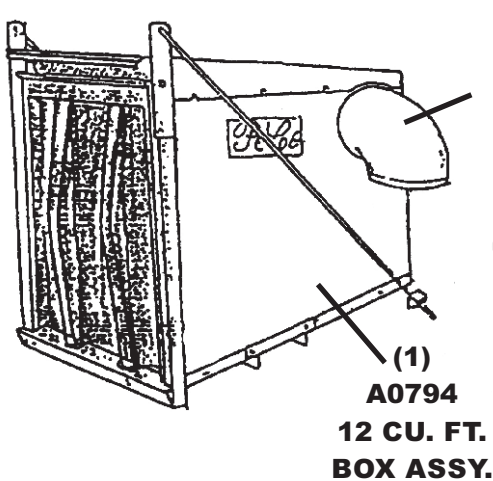

(1)
**A0794
12 CU. FT.
BOX ASSY.**

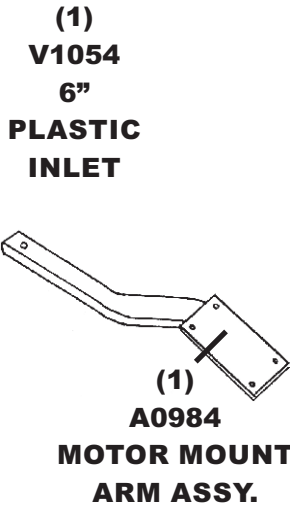

(1)
**A0984
MOTOR MOUNT
ARM ASSY.**



(1)
**A0060
70" THROTTLE
CABLE
KIT FOR (5.5 &
6.5HP)**



(1)
**#HB0018
HARDWARE
BAG**

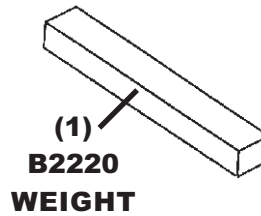

(1)
**B2220
WEIGHT**

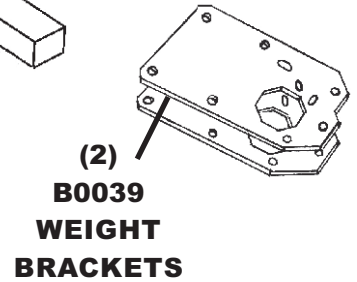

(2)
**B0039
WEIGHT
BRACKETS**

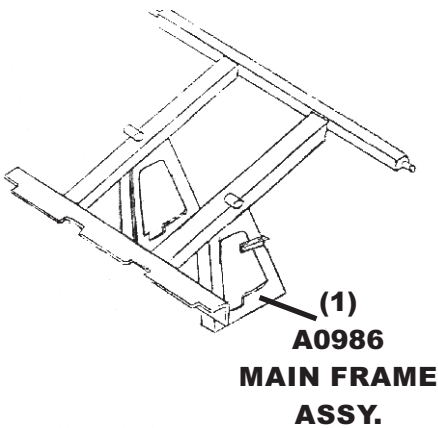

(1)
**A0986
MAIN FRAME
ASSY.**

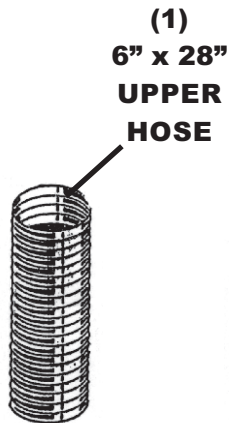

(1)
**6" x 28"
UPPER
HOSE**

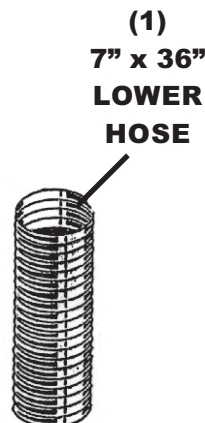

(1)
**7" x 36"
LOWER
HOSE**

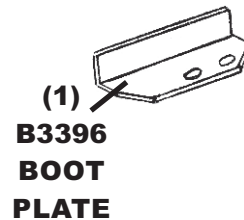

(1)
**B3396
BOOT
PLATE**

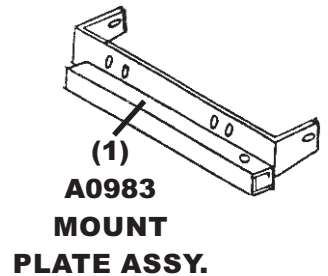

(1)
**A0983
MOUNT
PLATE ASSY.**

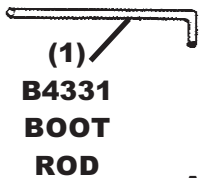

(1)
**B4331
BOOT
ROD**

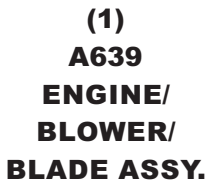

(1)
**A639
ENGINE/
BLOWER/
BLADE ASSY.**

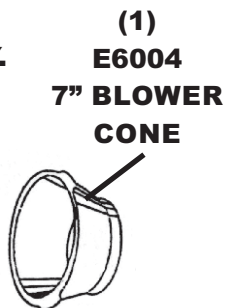

(1)
**E6004
7" BLOWER
CONE**

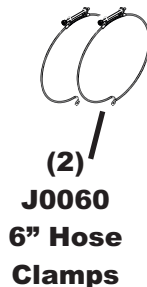

(2)
**J0060
6" Hose
Clamps**



(2)
**J0070
7" Hose
Clamps**



(1)
**E2406
BOOT**