



GRASS COLLECTION SYSTEM

DESIGNED FOR:

**MODEL# 22031531 & 22031539
TORO 500 SERIES PRO BAGGER**



OPERATOR'S MANUAL

ASSEMBLY ● OPERATION ● MAINTENANCE

PECO GRASS COLLECTION SYSTEM

TABLE OF CONTENTS

SECTION	PAGE	SECTION	PAGE
Safety	2	2-11 Length Of Hose Adjustment.....	12
Safety Alert Symbols.....	3	2-12 Upper Hose Installation	12
Warranty	4	2-13 Lower Hose To Blower Cone Installation.....	12
I INTRODUCTION AND DESCRIPTION.....	5	2-14 Lower Hose To Boot Installation.....	12
1-1 Introduction.....	5	2-15 Front Weight Installation.....	12
1-2 Description	5	2-16 Throttle Cable Installation	13
II INSTALLATION FOR USE.....	5	III OPERATING INSTRUCTIONS	14
2-1 Preparation Of Mower	5	3-1 General Safety.....	14
2-2 Lower Mount Assembly Installation.....	5	3-2 Operation & Tips On Mowing.....	14
2-3 Outer Mount Tube Assembly Installation	6	3-3 Unloading The Collection System.....	14
2-4 Engine mount Arm Assembly Installation	6	IV MAINTENANCE.....	14
2-5 Engine/Blower/Blade Assembly Installation.....	6	4-1 Maintenance Checklist.....	14
Exploded Parts Views And Assemblies.....	7-9	V PARTS AND SERVICE.....	15
2-6 Upper Frame Assembly Installation.....	10	5-1 Parts And Service Information.....	15
2-7 Top Assy. To Upper Frame Assy. Installation.....	10	Safety Decals	16
2-8 Boot Installation	10	Torque Specifications	17
2-9 Blower Cone Installation.....	11		
2-10 Impeller Blade Removal/Replacement.....	11		

Safety

1. Read the operator's manual carefully and familiarize yourself with the proper use of your attachment. Do not allow anyone who is not acquainted with the Safety Instructions to use your attachment.
2. Know the controls and how to stop quickly. **READ THE OPERATOR'S MANUAL!**
3. Do not allow children to operate the vehicle. Do not allow adults to operate it without proper instruction.
4. Be especially watchful of children and pets darting into the area while operating.
5. Keep your eyes and mind on your unit while mowing or operating your attachment. Don't let others distract you.
6. Do not attempt to operate your unit or mower when not in the driver's seat.
7. Always stop unit when emptying the container.
8. Stop unit, shut off deck attachment, set parking brake, shut off mower engine and remove spark plug wire before removing clogs, removing or replacing hose, boot, blower cone, or performing any maintenance.
9. Mow across the face of slopes (not steeper than 10 degrees); never up and down the face of the slope.
10. It is recommended that the container be kept only half full when negotiating any slopes. Start mowing on slopes when the container is empty.
11. Inspect your lawn and remove any foreign objects before mowing. Never deliberately run the mower across any foreign object.
12. Wear ear protection if the noise level is offensive.
13. Wear eye protection to prevent debris from damaging your eyes.

SAFETY

WARNING! **NEVER** operate the unit unless the discharge guard and either the deflector assembly or the vacuum collector adapter are fastened securely in place.

WARNING! Do not work around the mower deck boot or the blower area until you are certain that the mower blades and the blower impeller have stopped rotating.

WARNING! To avoid serious injury, perform maintenance on the vacuum collector; **ONLY AFTER STOPPING THE MOWER'S ENGINE AND WAITING FOR ALL MOVING PARTS TO COME TO A COMPLETE STOP.** Set the parking brake. Always remove the ignition key before beginning maintenance.

WARNING! For your own personal safety, **ALWAYS** mow **ACROSS** the face of slopes and **NEVER UP and DOWN** the face. **NEVER** attempt to mow excessively steep slopes, and use caution when turning on any slope.

Safety Alert Symbol



This Safety Alert Symbol means: **“ATTENTION! BECOME ALERT! YOUR SAFETY IS INVOLVED!”**

This symbol is used to call attention to safety precautions that should be followed by the operator to avoid accidents. When you see this symbol, carefully read the message that follows and heed its advice. Failure to comply with safety precautions could result in death or serious bodily injury.

Safety Signs

The signal words **DANGER**, **WARNING**, and **CAUTION** are used on the equipment safety signs. These words are intended to alert the viewer to the existence and the degree of hazard seriousness.



White letters on **RED**

This signal word indicates a potentially hazardous situation which, if not avoided, will result in death or serious injury.



Black letters on **ORANGE**

This signal word indicates a potentially hazardous situation which, if not avoided, could result in death or serious injury.

It may also be used to alert against unsafe practices.



Black letters on **YELLOW**

This signal word indicates a potentially hazardous situation exist which, if not avoided, will result in minor or moderate injury.

It may also be used to alert against unsafe practices.

PECO LIMITED WARRANTY FOR NEW PRODUCTS

A. WHAT IS WARRANTED?

PECO extends the following warranties to the original purchaser of each new PECO consumer product subject to the following limitations:

- 1. PRODUCT WARRANTY:** Any part of any consumer product, which is defective in material or workmanship as delivered to the purchaser will be repaired or replaced, as PECO elects, without charge for parts or labor, if the defect appears within 12 months from the date of delivery of the product to the original purchaser. **ALL DEFECTIVE PARTS MUST BE RETURNED TO PECO FOR INSPECTION TO DETERMINE VALIDITY OF WARRANTY CLAIMS.** Freight and mailing will be borne by the customer.
- 2. PARTS REPLACED DURING WARRANTY:** Any new PECO part which is furnished in performance of this warranty and is defective in material or workmanship as delivered to the purchaser will be repaired or replaced, as PECO elects, without charge if the defect appears within 90 days from the date of installation of such part or before the expiration of the original warranty period, whichever is later.

B. SECURING WARRANTY ADJUSTMENTS.

Call PECO for Return Authorization. Damaged or broken parts, other than engines or batteries, must be returned to PECO Inc., 100 Airport Road, Arden, NC 28704 before any warranty adjustment can be authorized. At the time of requesting warranty adjustment, the purchaser must present evidence for date of delivery of the product. The purchaser shall pay any charge for the product to and from Arden, NC.

C. ITEMS NOT COVERED BY PECO WARRANTY.

Engines and batteries attached to PECO products are covered under a separate warranty by the respective manufacturer.

D. UNAPPROVED ALTERATION OR MODIFICATION.

All obligations of PECO Inc., under this warranty, shall be terminated if products are altered or modified in ways not approved by PECO Inc..

E. ACCIDENTS AND NORMAL MAINTENANCE.

The warranty covers only defective material and workmanship. It does not cover depreciation or damage caused by normal wear, accident, improper use or abuse of products. The cost of normal maintenance and normal replacement of service items such as belts, cutting blades, hoses, etc., which are not defective shall be paid for by the purchaser.

F. NO REPRESENTATIONS ADDITIONAL WARRANTIES, DISCLAIMER.

Neither PECO Inc. nor any company affiliated with it makes any warranties, representations or promises as to the quality of performance of its products other than those set forth herein. Except as described above, PECO Inc. makes no other warranties **AND SPECIFICALLY DISCLAIMS ANY AND ALL IMPLIED WARRANTIES OF FITNESS AND MERCHANTABILITY.**

G. ANY MACHINE USED FOR RENTAL PURPOSES ARE GUARANTEED FOR 45 DAYS FROM DATE OF ORIGINAL SALE ONLY.

H. REMEDIED EXCLUSIVE.

The only remedies the purchaser has in connection with the breach or performance of any warranty on PECO Inc. consumer products are set forth above. In no event will PECO be liable for special incidental or consequential damages.

1. NO SERVICE CENTER WARRANTY.

The selling Service Center makes no warranty on his own on any item warranted by PECO Inc. unless he delivers to purchaser a separate written warranty certificate specifically warranting the item. The dealer has no authority to make any representation or promise on behalf of PECO or to modify the terms of this warranty in any way.

SECTION I

INTRODUCTION AND DESCRIPTION

1-1 Introduction

We are pleased to have you as a PECO customer. Your collection system has been designed to give you a low maintenance, simple, and effective way to collect the grass clippings from your mower. This manual is provided to give you the necessary instructions to properly mount and operate the collection system on your mower. Please read this manual thoroughly. Understand what each control is for and how to use it. Observe all safety decal precautions on the machine and noted throughout the manual.

NOTE: all references made to right, left, front, rear, top or bottom are as viewed from the normal operator's position on the mower.

1-2 Description

The collection system is designed for turf maintenance where there is a need to collect the grass clippings as the mower cuts the turf. It is also good for picking up leaves and twigs in pre-season and post-season clean-up.

The engine/blower/blade assembly, is mounted on the right side of the unit. The blower draws grass clippings from the discharge area of the cutter deck back to the (3) 4 cubic foot collection bags P#(G0003) at the rear portion of the mower frame. The operator can engage the engine/blower/blade assembly by starting the engine. Once the bags are full with clippings, they can be released to make for easy dumping.

Section II

INSTALLATION FOR USE

2-1 Preparation Of Mower

Carefully dismantle wooden shipping crate from around the components. Cut retaining straps and separate the parts. The collection system will have various parts located inside. Remove and sort all parts for easy identification.

NOTE: Before each step of assembly it will help to study the exploded drawings on pages 7-9.

Remove the hardware that attaches the rear bumper plate to the mower, and remove the rear bumper plate. See Figure 2-1a.

Figure 2-1a.

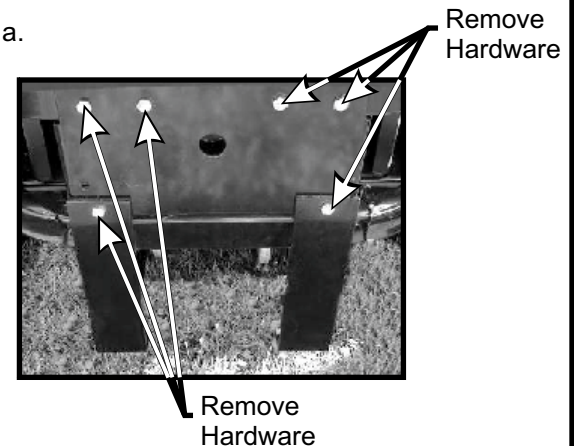

2-2 Attaching The Lower Mount Assembly

With the rear bumper plate removed, locate the (4) 1/4" spacers P#(B3287) over the mounting holes as shown in Figure 2-2a.

Figure 2-2a.

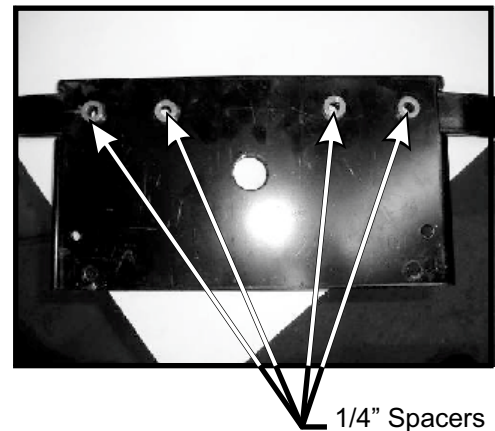

With the spacers in place, attach the lower mount assembly P#(A0617) to the rear bumper plate and then fasten the bumper plate to the mower frame using the existing hardware as shown in Figure 2-2b.

Figure 2-2b.

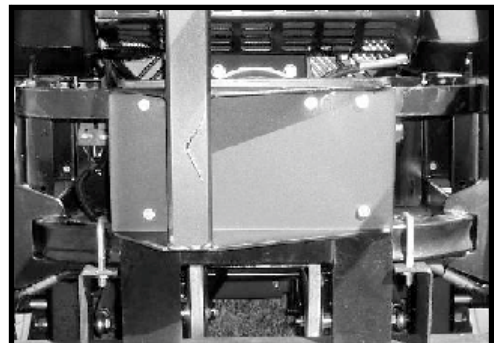

2-3 Outer Motor Mount Tube Installation

Attach the outer motor mount tube to the rear frame of the mower using (2) 3/8"-16 X 3" u-bolts P#(K1432) and (4) 3/8"-16 flange nuts P#(K1215). See Figure 2-3.

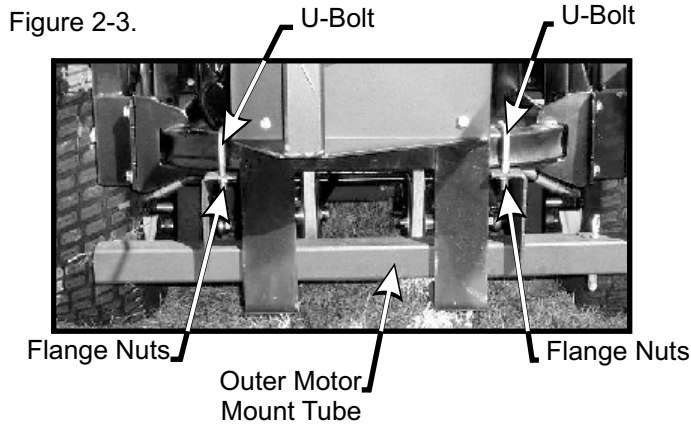

2-5 Engine/Blower/Blade Assembly

Place the engine/blower/blade assembly onto the engine mount arm assembly and align the mounting holes. Fasten by using (4) 5/16"-18 x 1-1/2" HHCS P#(K1157) and (4) 5/16"-18 flange nuts P#(K1178). See the figures below for detail.

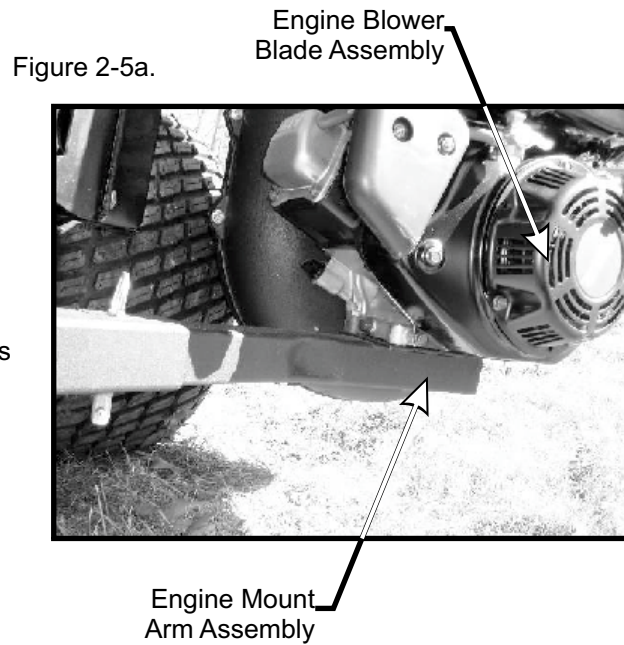

2-4 Engine Mount Arm Assembly Installation

Insert the engine mount arm assembly P#(A0903) into the outer motor mount tube and fasten with (1) detent pin P#(J0248). See Figure 2-4.

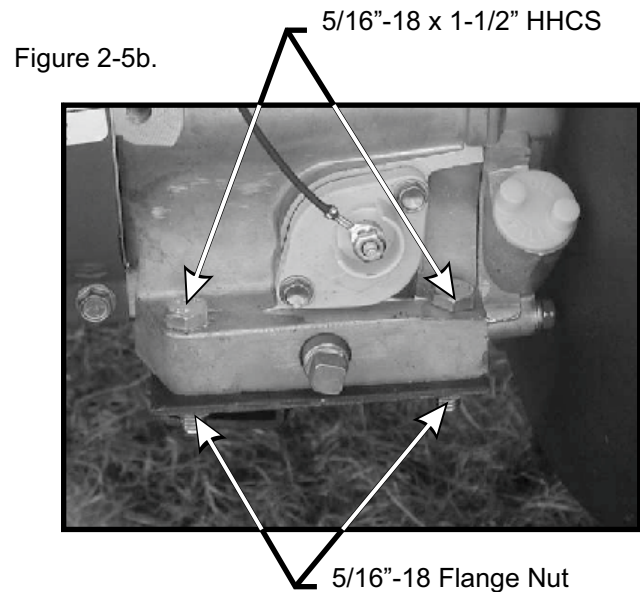
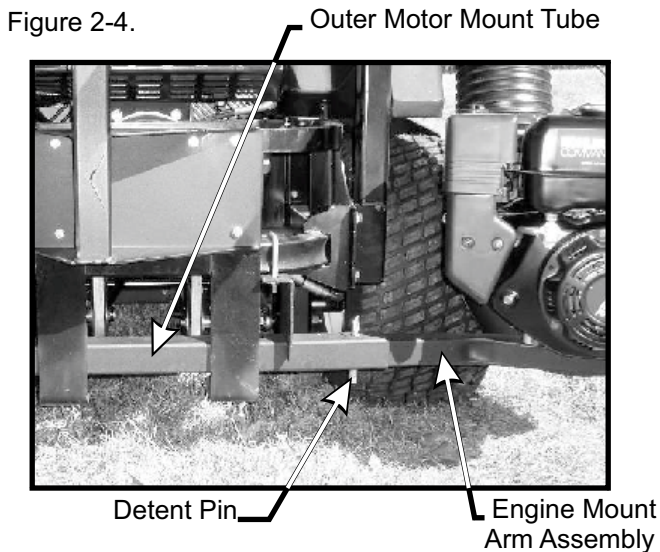

MODEL#: 22031531

MOWER NAME: TORO

MOWER MODEL: 400 & 500 SERIES

MOWER DECK SIZE: 48", 52" & 60"

VAC NAME: 15 CUBIC FOOT PRO BAGGER

ENG: 900 SER. BR (9.00 GROSS TORQUE / 205 CC)

BOM0302



FOR YEAR: 2007 - 2005

REVISED: 5/9/2012

A0742 UNIT ASSEMBLY

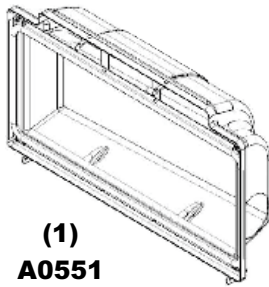

(1)
**A0551
TOP
ASSEMBLY**



(1)
**V1054
6" PLASTIC
INLET**



(1)
**8" x 41"
LOWER
HOSE**



(1)
**6" x 27"
UPPER
HOSE**

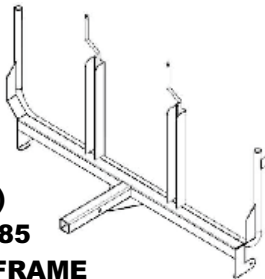

(1)
**A0585
UPPER FRAME
ASSEMBLY**



(2)
**J6006
7" - 8"
HOSE
CLAMPS**

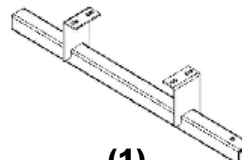

(1)
**A0110
OUTER MOTOR
MOUNT TUBE**



(1)
**A0617
LWR. MNT.
ASSEMBLY**



(1)
**#HB0307
HARDWARE
BAG**



(3)
**A0584
BAG RING
ASSEMBLY**

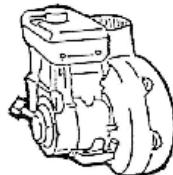

(1)
**ENGINE/
BLOWER/
BLADE ASSY.**



(1)
**E6009
8"
BLOWER**



(1)
**A0903
ENGINE MOUNT
ARM ASSY.**

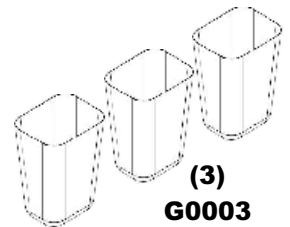

(3)
**G0003
4 CU. FT.
COLLECTION
BAGS**

A0563 - WEIGHT KIT

(2)
**B0026
WEIGHT
BRACKET**

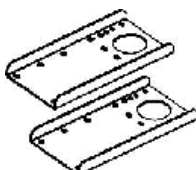

(1)
**#HB0206
HARDWARE
BAG**



(1)
**B2220
WEIGHT**

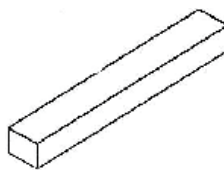

A0562 - 60" BOOT KIT

(1)
**#HB0207
HARDWARE
BAG**



(1)
**B0201
BOOT
PLATE**



(1)
**E1039
BOOT**

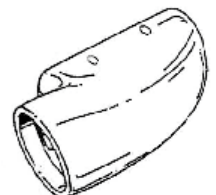

MODEL#: 22031539

MOWER NAME: TORO

MOWER MODEL: 500 SERIES

MOWER DECK SIZE: 48", 52" & 60"

VAC NAME: 15 CUBIC FOOT PRO BAGGER

6.5 BRIGGS AND STRATTON VANGUARD

BOM0303



FOR YEAR: 2008 - 2005

REVISED: 12/20/11

A0743 UNIT ASSEMBLY

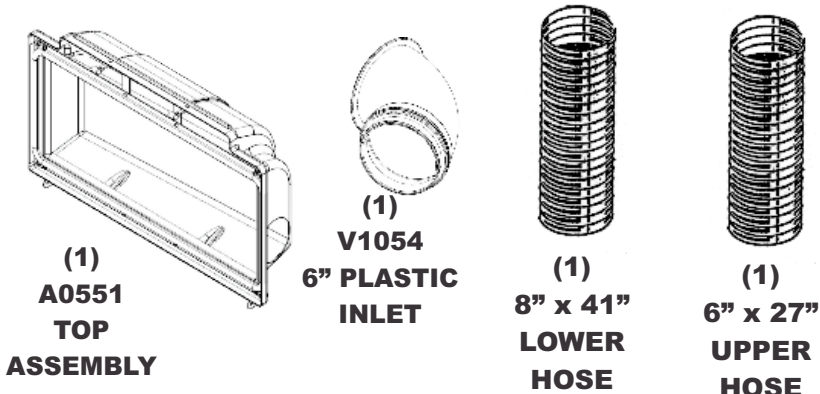

(1)
A0551
TOP
ASSEMBLY

(1)
V1054
6" PLASTIC
INLET

(1)
8" x 41"
LOWER
HOSE

(1)
6" x 27"
UPPER
HOSE

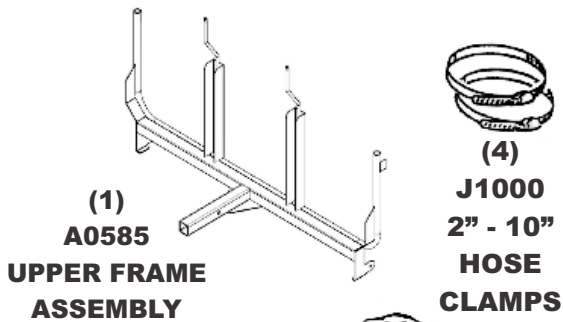

(1)
A0585
UPPER FRAME
ASSEMBLY

(4)
J1000
2" - 10"
HOSE
CLAMPS

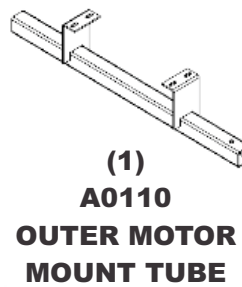

(1)
A0110
OUTER MOTOR
MOUNT TUBE



(1)
A0617
LWR. MNT.
ASSEMBLY



(1)
#HB0307
HARDWARE
BAG

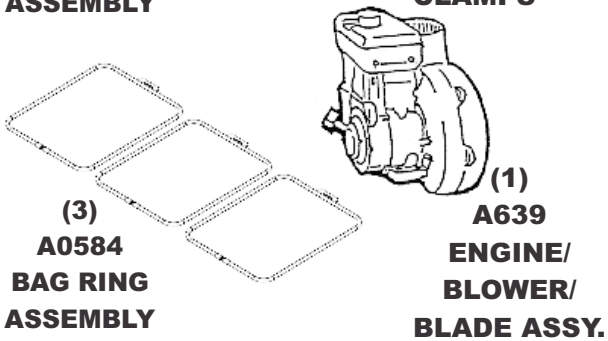

(3)
A0584
BAG RING
ASSEMBLY

(1)
A639
ENGINE/
BLOWER/
BLADE ASSY.



(1)
E6009
8" BLOWER
CONE

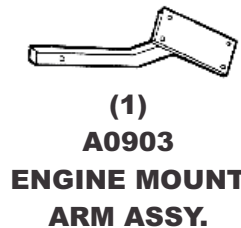

(1)
A0903
ENGINE MOUNT
ARM ASSY.

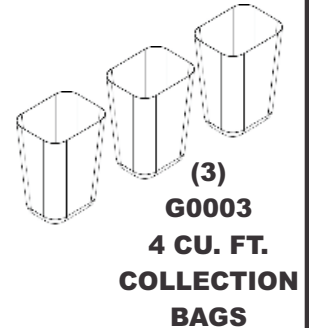

(3)
G0003
4 CU. FT.
COLLECTION
BAGS

A0563 - WEIGHT KIT



(2)
B0026
WEIGHT
BRACKETS

(1)
#HB0206
HARDWARE
BAG

(1)
B2220
WEIGHT

A0562 - 60" BOOT KIT

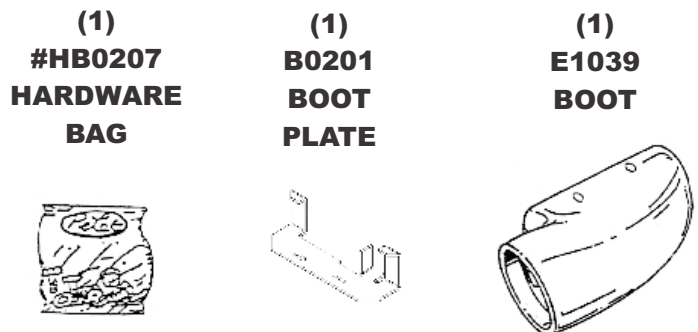

(1)
#HB0207
HARDWARE
BAG

(1)
B0201
BOOT
PLATE

(1)
E1039
BOOT

Figure 9.
Exploded View Of The
A0551 - Bagger Assembly

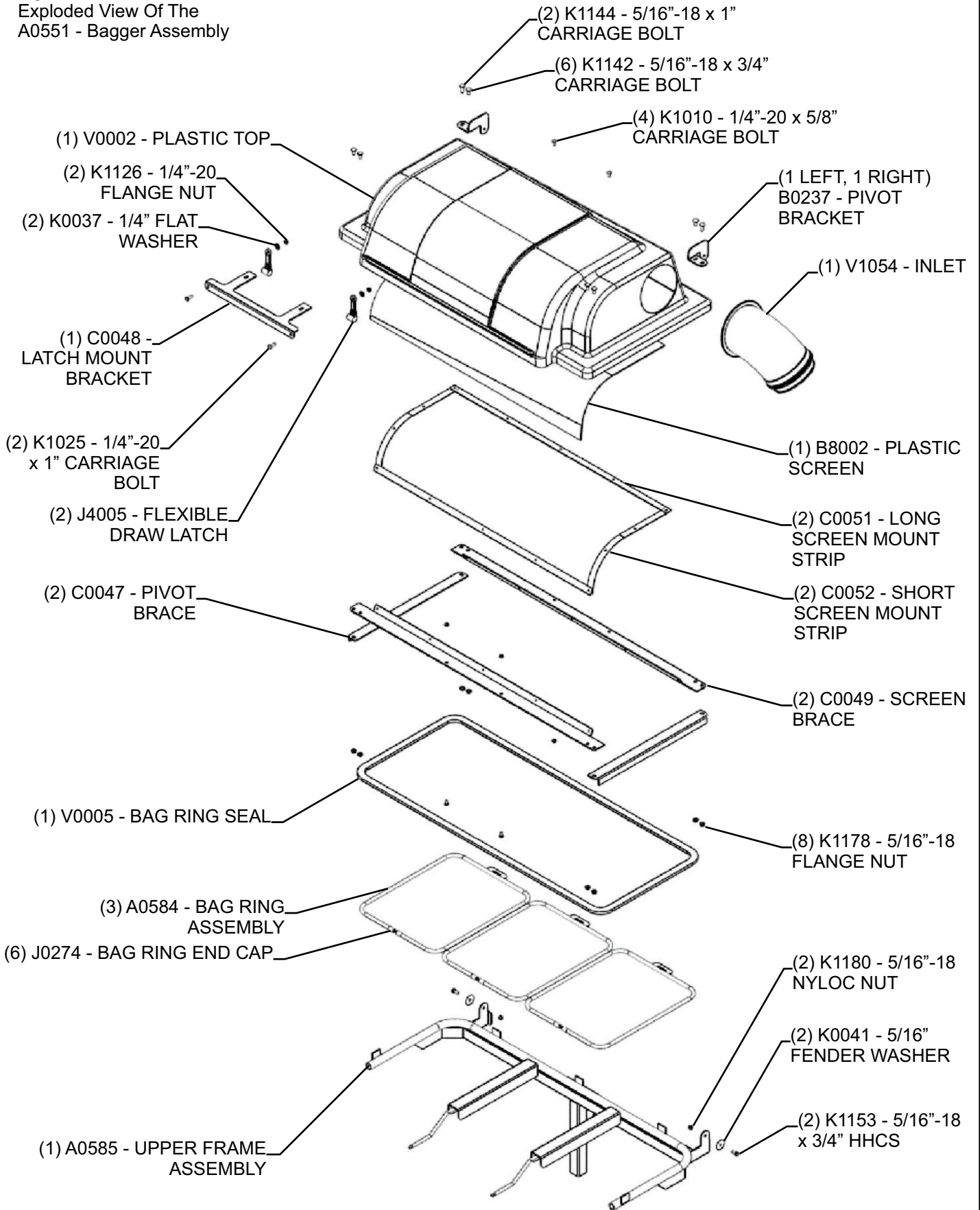

2-6 Upper Frame Assembly Installation

NOTE: During this step, it is suggested that two people install the upper frame to the lower mount tube.

Using (2) people to lift the upper frame, lift the upper frame above the lower mount assembly P#(A0617) making sure the frame is pointing away from the mower (Figure 2-6). Slide the upper frame tube into the lower mount assembly aligning the mounting hole. Insert (1) 1/2" x 2-1/2" clevis pin P#(K0133) through the hole and fasten with (1) 5/32" x 2-5/8" hair pin clip P#(K0088).

Figure 2-6.

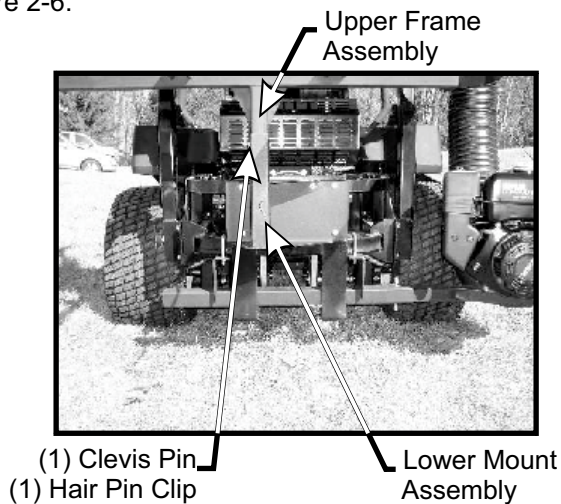

2-7 Top Assembly To Upper Frame Assembly Installation

Align the pivot brackets of the top assembly P#(A0551) to the pivot point on either side of the upper frame assembly. Place (1) P#(K0041) fender washer between each pivot point (Figure 2-7) and fasten each side by using (1) P#(K1153) 5/16"-18 x 3/4" HHCS and (1) P#(K1180) 5/16"-18 nyloc nut. When fastening leave nut slightly loose so that the top can pivot freely.

Figure 2-7.

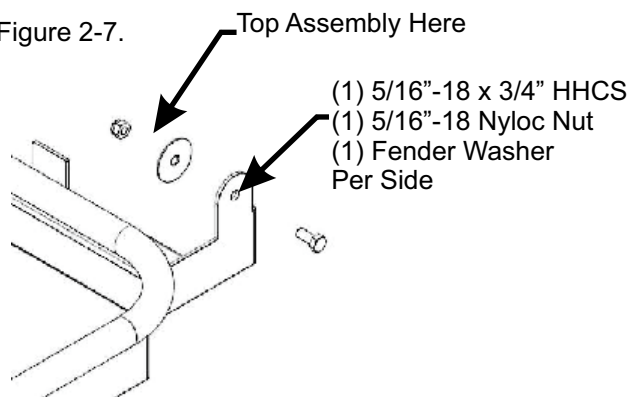

2-8 Boot Installation

Mounting The Boot Plate

To mount the boot plate P#(B0201) to the boot P#(E1039) use (2) 3/8"-16 x 1" carriage bolts P#(K1182) and (2) 3/8"-16 flange nuts P#(K1215).

NOTE: Make certain when bolting the boot and boot plate together, that the head of the bolt is placed from the inside of the boot. This will prevent grass from collecting on the bolts.

To install the boot plate and boot to the deck, lift boot plate assembly to a 45 degree angle and slide bent tabs under the deflector shield as shown in Figure 2-8. Adjust boot as needed to insure proper fit.

The boot plate will allow you to switch from collection to discharge in seconds.

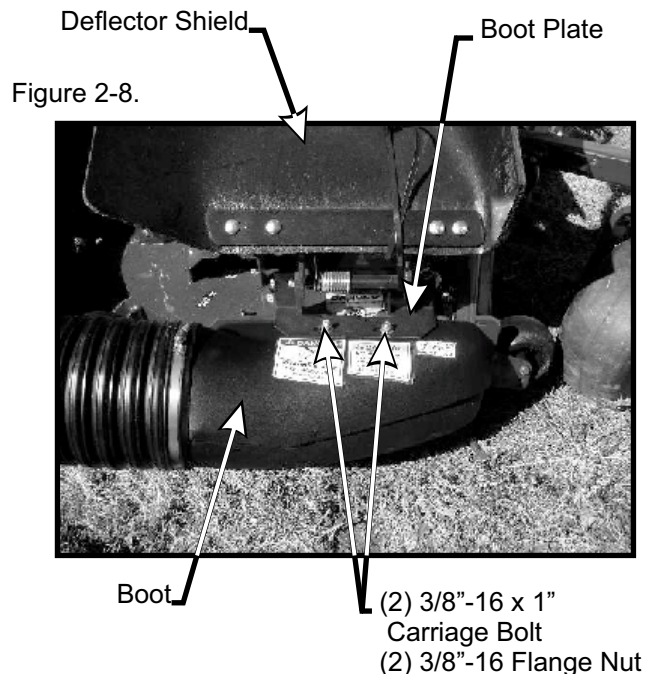
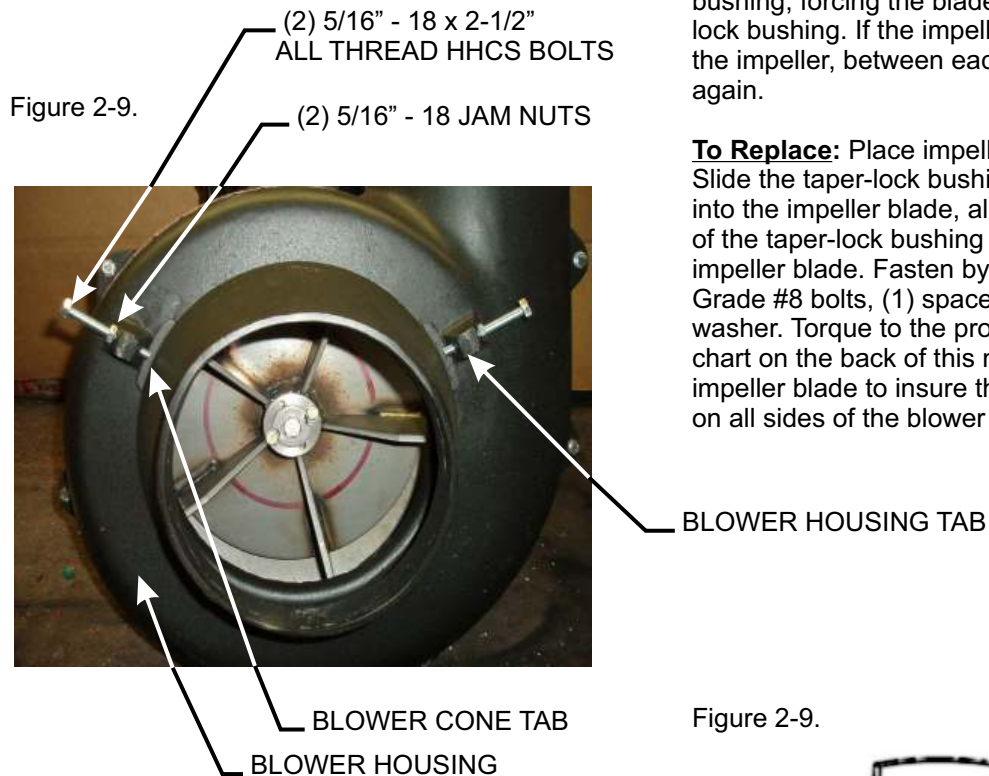

Figure 2-8.

2-9 Blower Cone Installation

Thread (1) 5/16"-18 jam nut P#(K0120) onto each end of (2) 5/16"-18 x 2-1/2" HHCS P#(K0125). Now partially thread the bolts into each of the two tabs located on the blower housing. Place blower cone so the two tabs line up with the bolts then tighten completely. See Figure 2-9.



2-10 Impeller Blade Removal/Replacement

To Remove: First remove the center bolt (#1), washer (#2) and spacer (#3) from the taper-lock bushing (#5). See Figure 2-10. Next remove the (2) 1/4"-20 bolts (#4) and place them into the threaded holes of the taper-lock bushing (next to the holes they were removed from). Gradually thread each bolt evenly into the taper-lock bushing, forcing the blade to break-away from the taper-lock bushing. If the impeller will not move, hit the base of the impeller, between each vein, with a hammer, then try again.

To Replace: Place impeller blade over the engine shaft. Slide the taper-lock bushing on to the engine shaft and into the impeller blade, aligning the **non-threaded** holes of the taper-lock bushing to the threaded holes of the impeller blade. Fasten by using (2) 1/4"-20 HHCS Grade #8 bolts, (1) spacer washer and (1) HHCS bolt w/ washer. Torque to the proper specifications in the torque chart on the back of this manual. Next, rotate the impeller blade to insure that the blade is clear of contact on all sides of the blower housing.

Figure 2-9.

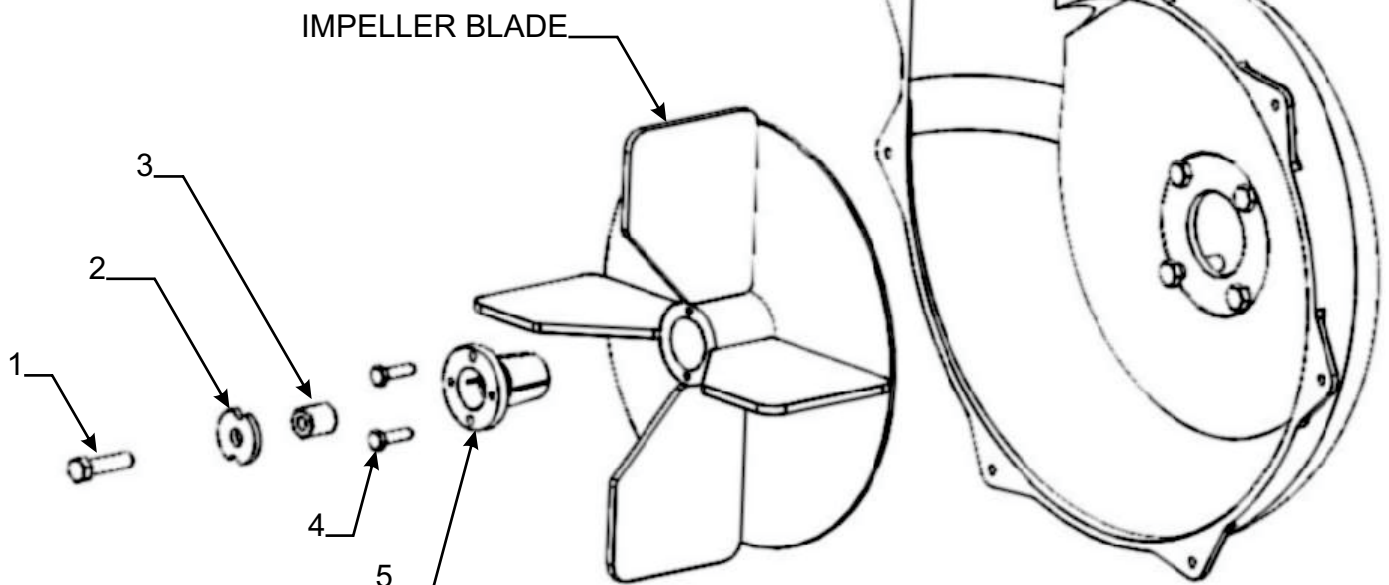

2-11 Length Of Hose Adjustment

The hoses in steps 2-12 and 2-13 must be cut to fit your machine. Follow steps 2-12 and 2-13. Do not cut the hoses until you have tried to fit them on your machine. Remember that the hoses have to be long enough to allow for enough clamping surface between the inlet, blower assembly, and the deck boot, but have to remain short enough to prevent hose "kinks".

2-12 Upper Hose Installation

Slide a 5"-6" upper hose clamp P#(J6011) onto both ends of the 6" upper hose (Figure 2-13). Then slide one end of the 6" hose onto the inlet. Make sure there is about a two-inch overlap between the hose end and the container inlet. Proceed to slide the opposite end of the 6" hose onto the outlet of the blower assembly. See Figure 2-13 for details. Make sure both ends of the hose are clearly attached to the inlet and the blower assembly inlet. Tighten the hose clamps.

2-13 Lower Hose To Blower Cone Installation

Slide a 7"-8" hose clamp P#(J6006) over both ends of the lower hose. Then proceed to slide the lower hose onto the blower cone. Tighten the hose clamp. The assembly should look like Figure 2-13.

Figure 2-13.

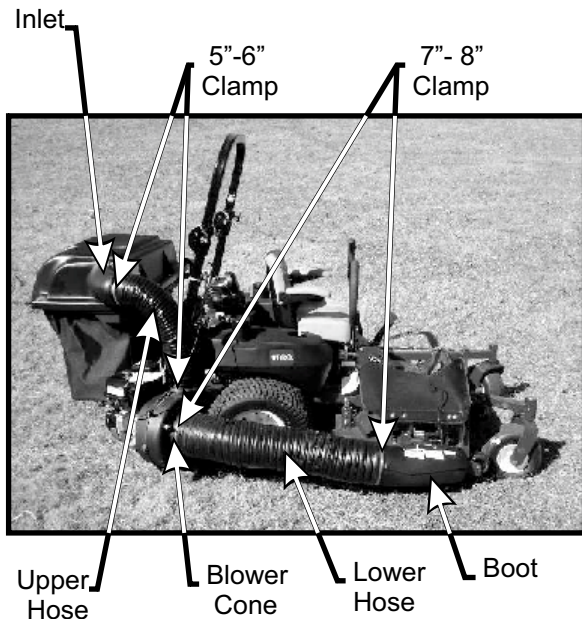

2-14 Lower Hose To Boot Installation

Take the unattached end of the lower hose and slide it over the circular end of the boot. Use the lower hose clamp to secure the hose to the boot (Figure 2-14). Tip: Before securing clamp rotate hose counter-clockwise (away from yourself) approximately 1" to add in retaining boot to mower deck.

Figure 2-14.

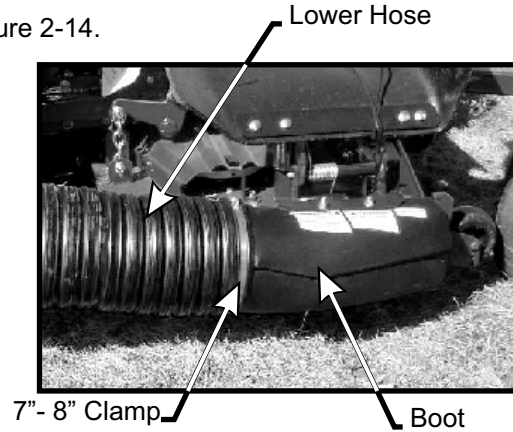

2-15 Front Weight Installation

Fasten the weight to the weight brackets using (2) 1/2"-13 U-Bolts P#(K1419) and (4) 1/2"-13 Flange Nuts P#(K1246). See Figure 2-15a.

Figure 2-15a.

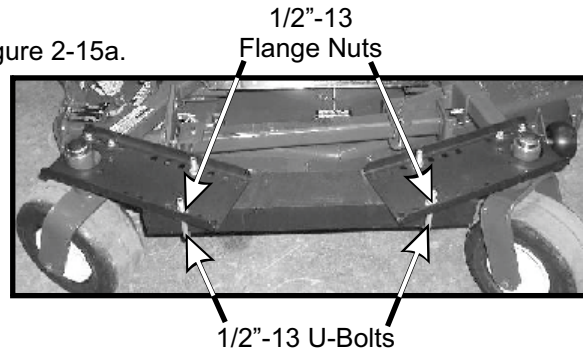

Attach the weight kit to the mower using the mounting holes on the weight brackets. Fasten with (2) 3/8"-16 U-Bolts P#(K0331) and (4) 3/8"-16 Flange Nuts P#(K1215). See Figure 2-15b.

Figure 2-15b.

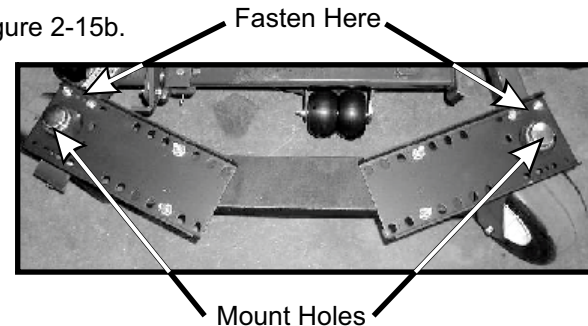

2-16 Throttle Cable Installation

To install the throttle cable kit to the ROPS (roll over protection system), place the 3/8" U-Bolt P#(K0136) onto the ROPS with the threads facing the front of the mower. Next slide on the throttle mount plate assembly P#(A0666) with the rivets also facing toward the front of the mower. Tighten the throttle mount plate assembly securely to the ROPS using (2) 3/8"16 flange nuts P#(K1215) (Figure 2-16a). With the throttle cable facing toward the engine/blower/blade assembly, place the throttle base plate over the rivets. Slide the throttle cable kit to the right, moving the smaller end of the slot over the rivets. When positioned correctly, the throttle spring plate will snap into place (Figure 2-16b).

NOTE: If mower is not equipped with a ROPS Install the throttle cable kit to the upper frame assembly P#(A0585) using the same steps as above. Make sure to locate the throttle cable kit where it can be easily accessed from the operator's seat.

To remove the throttle cable kit, lift the throttle spring plate and slide the throttle kit to the left.

Route cable over upper hose as shown in Figure 2-16c.

Figure 2-16a.

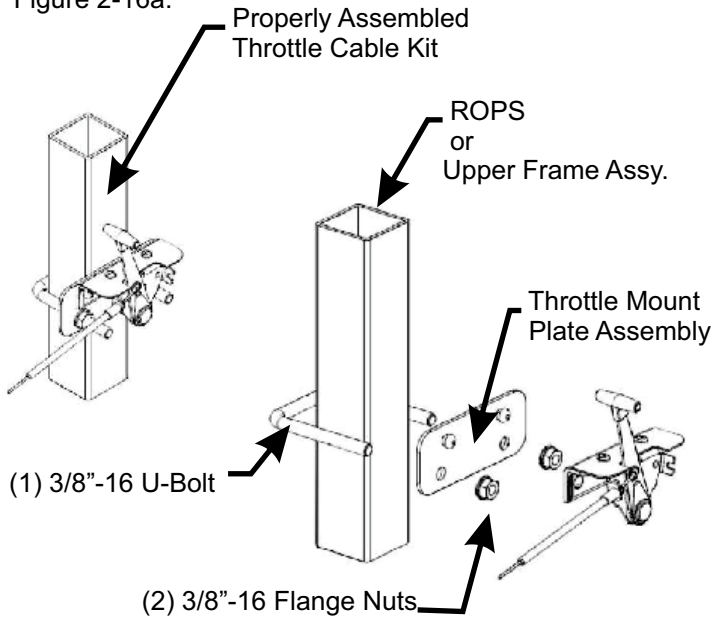

Figure 2-16b.

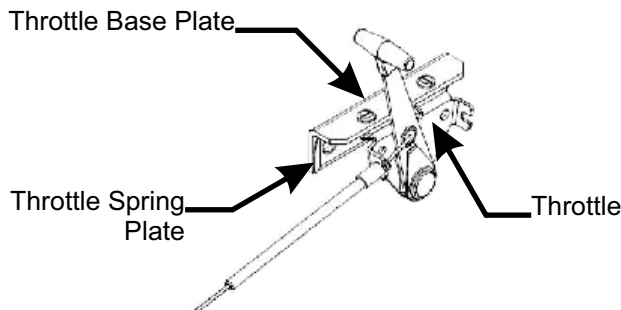
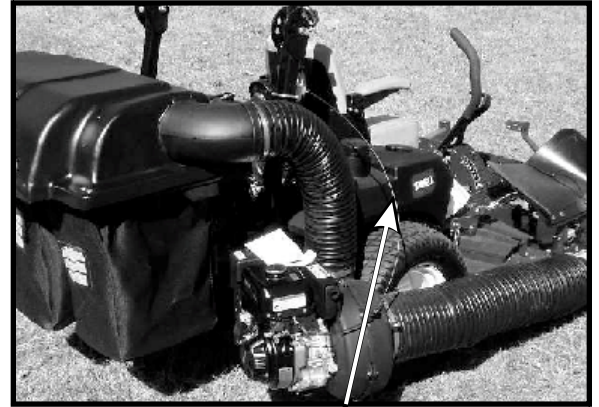

Figure 2-16c.



Route Throttle Cable
Over Upper Hose

To fasten the throttle cable end to the engine, place the throttle control lever into the "stop" position. Rotate the engine throttle lever to the "stop" position. Thread the wire end of the throttle cable into the engine throttle lever eyelet and tighten the screw. Fasten the throttle cable sleeve to the clamp on the engine throttle (Figure 2-16d). Rotate the throttle control lever into the "fast" position to check for proper installation.

NOTE: Cable sleeve may need to be cut, depending on the engine type. Once throttle cable is attached, pull the box handle to dump the box and be sure the cable does not alter the movement of the box.

Figure 2-16d.

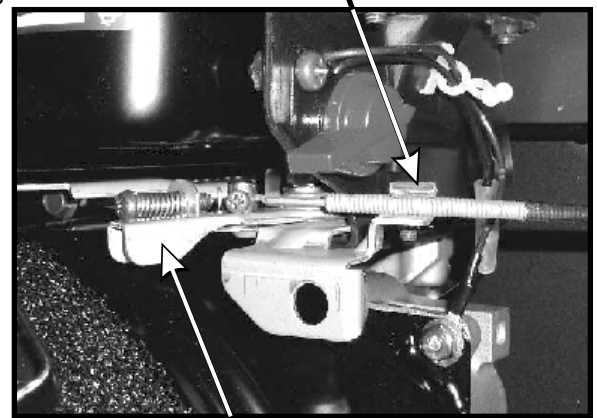

Engine Throttle Lever

SECTION III

OPERATING INSTRUCTIONS

3-1 General Safety

Only qualified people familiar with this operator's manual and the mower's operator's manual should operate this machine.

3-2 Operation & Tips On Mowing

- A. Perform BEFORE EACH USE maintenance list in paragraph 4-1.
- B. Start the engine/blower/blade assembly.
- B. Start mower.
- C. With the mower at high idle speed, engage the mower deck.
- D. Proceed to operate the control levers of the mower.

NOTE: If the collection system does not appear to be collecting the grass clippings; disengage the deck, and blower, engage the parking brake and turn the mower off. Check the upper hose, lower hose, top screen and boot for clogs.

To obtain the maximum effectiveness from your collection system the tips listed below should be followed:

- * Watch your speed- Normal conditions will allow a speed of up to approximately 5 mph, but thick, heavy damp conditions will require reduced ground speed.
- * Mow with sharp blades- A sharp blade cuts cleaner.
- * Wet grass and leaves will decrease effectiveness and will increase horsepower requirements.
- * Mow at higher cutting heights- Remove and mulch no more than 2" of grass length with each mowing. (Experts recommend not cutting off more than 1/3 of the grass blade length at any given time.)
- * Mow twice, at different height settings, (high, then low), if grass is extra tall.
- * Remember that horsepower requirements will vary with the mowing conditions such as type and height of turf grass, moisture content, amount of leaves, whether the terrain is flat or sloped, etc.

3-3 Unloading The Collection System

- A. Stop the forward movement of the mower.
- B. Disengage the mower deck.
- C. Using the throttle cable slow the engine down to idle.
- D. Engage the parking brake.

- E. Once the parking brake has been engaged, then and only then, walk behind the mower and check the collection bags by lifting the plastic hood. Load in bags should not exceed the height of the installed bag.
- F. To release bags from frame, lift bag ring from tab on bagger frame, slide bag out and turn bags over to deposit clippings.
- G. Follow steps on page 14 to re-attach bags back to the bagger.

NOTE: Do not allow collection bags to become over-filled as potential damage may occur to your equipment. Also, be sure to clean the hood screen as needed.

SECTION IV

MAINTENANCE

4-1 Maintenance Checklist

Before each use:

1. Check blades and spindles to be sure that no foreign objects, such as wire or steel strapping bands, are wrapped around them.
2. Inspect blades for wear. Replace if necessary. If it is necessary to sharpen the blades, remove the blades from the spindles before sharpening. DO NOT sharpen blades while still attached to the mower.
3. Make sure all shields are in place and in good condition. Repair or replace any missing or damaged shields.
4. Listen for abnormal sounds, which might indicate loose parts, damaged bearings, or other damage. Correct any deficiency before continuing operation.
5. Check for wear or deterioration of the upper or lower hoses. If there are any portions of the hose that have been torn or worn through, replace with genuine PECO parts.

After Each Use:

1. Clean all debris from machine especially from the container, and off of safety decals. Replace any missing or illegible decals.
2. Clean all debris from the box screen.
3. Inspect unit for worn or damaged components. Repair or replace before the next use. Any replacement component installed during repair shall include the components current safety decal specified by the manufacturers to be affixed to the component.

SECTION V PARTS AND SERVICE

5-1 Parts And Service Information

PECO collection system owners should record the name and telephone number of their Service Center. Your Service Center will be happy to supply replacement parts, accessories, and do any service or repairs to your collection system. If for any reason your Service Center is unable to service your collection system or supply replacement parts, contact PECO and include the following information on the chart below.

THE SERIAL NUMBER PLATE
IS LOCATED ON THE TOP
ASSEMBLY P#(A0551)

PECO	
OUTDOOR POWER EQUIPMENT	
Model Number	<input type="text"/>
Serial Number	<input type="text"/>
Arden, North Carolina 28704	

WRITE THE MODEL AND SERIAL NUMBER IN
THE BOX ABOVE FOR FUTURE REFERENCE.

Turn any PECO Lawn Vac into a total lawn grooming tool with the PECO Wand Kit!

With your PECO Wand Attachment you will double the ability of your PECO Lawn Vac. Using the same powerful vacuum/blower that makes your Lawn Vac work so well, you will be able to get to all those hard-to-reach places where you needed a rake or broom before.

Contact PECO Today!



Unit Model Number: _____

Unit Engine Size: _____

Unit Serial Number: _____

Date of purchase: ____/____/____

Dealer/Distributor Name: _____

Address: _____ **State:** _____ **Zip:** _____

Phone Number: _____

Address: PECO Inc.
100 AIRPORT ROAD
Arden, NC 28704

Phone #: (828) 684-1234 or Toll Free: (800) 438-5823

Email: peco@lawnvac.com

SAFETY DECALS

To promote safe operation, PECO supplies safety decals on all products manufactured. Damage can occur to safety decals either through shipment, use or reconditioning. Contact your local Service Center for replacement decals.



Part #: R1054



Part #: R1069



Part #: R1057



Part #:R4015



Part #:R4054



Part #: R1065

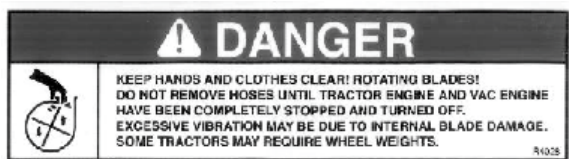

Part #: R4028



Part #:R4008



Part #:R1051



Part #: R1090

TORQUE SPECIFICATIONS

Proper torque for American fasteners used on Peco equipment.
Recommended Torque in Foot Pounds (Newton Meters).*

AMERICAN Bolt Head Markings



SAE Grade 2
(No Dashes)

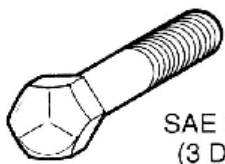

SAE Grade 5
(3 Dashes)

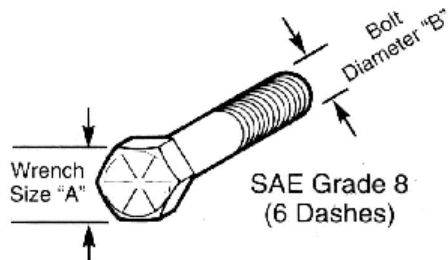

SAE Grade 8
(6 Dashes)

WRENCH SIZE (IN.) "A"	BOLT DIAMETER (IN.) "B" AND THREAD SIZE	SAE GRADE 2	SAE GRADE 5	SAE GRADE 8
7/16	1/4 - 20 UNC	6 (7)	8 (11)	12 (16)
7/16	1/4 - 28 UNF	6 (8)	10 (13)	14 (18)
1/2	5/16 - 18 UNC	11 (15)	17 (23)	25 (33)
1/2	5/16 - 24 UNF	13 (17)	19 (26)	27 (37)
9/16	3/8 - 16 UNC	20 (27)	31 (42)	44 (60)
9/16	3/8 - 24 UNF	23 (31)	35 (47)	49 (66)
5/8	7/16 - 14 UNC	32 (43)	49 (66)	70 (95)
5/8	7/16 - 20 UNF	36 (49)	55 (75)	78 (106)
3/4	1/2 - 13 UNC	49 (66)	76 (103)	106 (144)
3/4	1/2 - 20 UNF	55 (75)	85 (115)	120 (163)
7/8	9/16 - 12 UNC	70 (95)	109 (148)	153 (207)
7/8	9/16 - 18 UNF	79 (107)	122 (165)	172 (233)
15/16	5/8 - 11 UNC	97 (131)	150 (203)	212 (287)
15/16	5/8 - 18 UNF	110 (149)	170 (230)	240 (325)
1-1/8	3/4 - 10 UNC	144 (195)	266 (360)	376 (509)
1-1/8	3/4 - 16 UNF	192 (260)	297 (402)	420 (569)
1-5/16	7/8 - 9 UNC	166 (225)	430 (583)	606 (821)
1-5/16	7/8 - 14 UNF	184 (249)	474 (642)	668 (905)
1-1/2	1 - 8 UNC	250 (339)	644 (873)	909 (1232)
1-1/2	1 - 12 UNF	274 (371)	705 (955)	995 (1348)
1-1/2	1 - 14 UNF	280 (379)	721 (977)	1019 (1381)
1-11/16	1-1/8 - 7 UNC	354 (480)	795 (1077)	1288 (1745)
1-11/16	1-1/8 - 12 UNF	397 (538)	890 (1206)	1444 (1957)
1-7/8	1-1/4 - 7 UNC	500 (678)	1120 (1518)	1817 (2462)
1-7/8	1-1/4 - 12 UNF	553 (749)	1241 (1682)	2013 (2728)
2-1/16	1-3/8 - 6 UNC	655 (887)	1470 (1992)	2382 (3228)
2-1/16	1-3/8 - 12 UNF	746 (1011)	1672 (2266)	2712 (3675)
2-1/4	1-1/2 - 6 UNC	870 (1179)	1950 (2642)	3161 (4283)
2-1/4	1-1/2 - 12 UNF	979 (1327)	2194 (2973)	3557 (4820)

METRIC

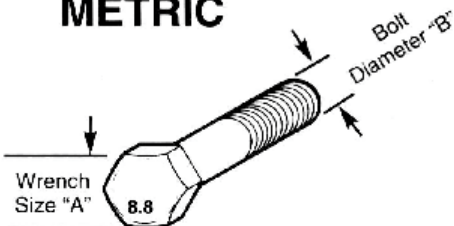

Numbers appearing on bolt heads indicate ASTM class.

Proper torque for metric fasteners used on Peco equipment.
Recommended torque in foot pounds (newton Meters).*

WRENCH SIZE (mm) "A"	BOLT DIA. (mm) "B"	ASTM 4.6	ASTM 8.8	ASTM 9.8	ASTM 10.9
8	5	1.8 (2.4)		5.1 (6.9)	6.5 (8.8)
10	6	3 (4)		8.7 (12)	11.1 (15)
13	8	7.3 (10)		21.1 (29)	27 (37)
16	10	14.5 (20)		42 (57)	53 (72)
18	12	25 (34)	74 (100)	73 (99)	93 (126)
21	14	40 (54)	118 (160)	116 (157)	148 (201)
24	16	62 (84)	167 (226)	181 (245)	230 (312)
30	20	122 (165)	325 (440)		449 (608)
33	22		443 (600)		611 (828)
36	24	211 (286)	563 (763)		778 (1054)
41	27		821 (1112)		1138 (1542)
46	30	418 (566)	1119 (1516)		1547 (2096)

*Use 75% of the specified torque value for plated fasteners. Use 85% of the specified torque values for lubricated fasteners.



**100 AIRPORT ROAD
ARDEN, NORTH CAROLINA 28704
(800) 438-5823 OR (828) 684-1234 FAX: (828) 684-0858
EMAIL: peco@lawnvac.com
WEBSITE: www.lawnvac.com**