



PRO 3 BAGGER
DECK DRIVE
GRASS COLLECTION
SYSTEM

DESIGNED FOR
EXMARK LAZER Z
48" AND 52" DECKS



MODEL: 35031503 - 48" DECK
MODEL: 35031504 - 52" DECK

OPERATOR'S MANUAL

ASSEMBLY ● OPERATION ● MAINTENANCE

PECO GRASS COLLECTION SYSTEM

TABLE OF CONTENTS

SECTION	PAGE	SECTION	PAGE
Safety	2	2-12 Pulley Guard Installation	11,12
Safety Alert Symbols	3	2-13 Inlet and Hose Installation	12
Warranty	4	2-14 Installation / Removal of Collection Bags	13
I INTRODUCTION AND DESCRIPTION	5	2-15 Front Weight Assembly Installation	14
1-1 Introduction	5	Exploded Parts Views And Assemblies	15-22
1-2 Description	5	III OPERATING INSTRUCTIONS	23
II PREPARATION FOR USE	5	3-1 General Safety	23
2-1 Preparation Of Mower	5	3-2 Operation & Tips On Mowing	23
2-2 Lower Main Frame Leg Installation	5,6	3-3 Unloading The Collection System	23
2-3 Outer Engine Mount Tube Assembly Installation	6	IV MAINTENANCE	23
2-4 Lower Clamp Bracket	6,7	4-1 Maintenance Checklist	23
2-5 Exhaust Diverter Installation	7	V PARTS AND SERVICE	24
2-6 Exhaust Deflector Plate	7	5-1 Parts And Service Information	24
2-7 Upper Frame Assembly Installation	7,8	Safety Decals	25
2-8 Top Assy To Upper Frame Assy Installation	8	Torque Specifications	26
2-9 Deck Pulley Installation	8,9	Notes	27
2-10 Deck Drive Assembly Installation	9		
2-11 Belt Installation	10,11		

Safety

- 1.** Read the operator's manual carefully and familiarize yourself with the proper use of your attachment. Do not allow anyone who is not acquainted with the Safety Instructions to use your attachment.
- 2.** Know the controls and how to stop quickly. **READ THE OPERATOR'S MANUAL!**
- 3.** Do not allow children to operate the vehicle. Do not allow adults to operate it without proper instruction.
- 4.** Be especially watchful of children and pets darting into the area while operating.
- 5.** Keep your eyes and mind on your unit while mowing or operating your attachment. Don't let others distract you.
- 6.** Do not attempt to operate your unit or mower when not in the driver's seat.
- 7.** Always stop unit when emptying the container.
- 8.** Stop unit, shut off deck attachment, set parking brake, shut off mower engine and remove spark plug wire before removing clogs, removing or replacing hose, boot, blower cone, or performing any maintenance.
- 9.** Mow across the face of slopes (not steeper than 10 degrees); never up and down the face of the slope.
- 10.** It is recommended that the container be kept only half full when negotiating any slopes. Start mowing on slopes when the container is empty.
- 11.** Inspect your lawn and remove any foreign objects before mowing. Never deliberately run the mower across any foreign object.
- 12.** Wear ear protection if the noise level is offensive.
- 13.** Wear eye protection to prevent debris from damaging your eyes.

SAFETY

WARNING! NEVER operate the unit unless the discharge guard and either the deflector assembly or the vacuum collector adapter are fastened securely in place.

WARNING! Do not work around the mower deck boot or the blower area until you are certain that the mower blades and the blower impeller have stopped rotating.

WARNING! To avoid serious injury, perform maintenance on the vacuum collector; **ONLY AFTER STOPPING THE MOWER'S ENGINE AND WAITING FOR ALL MOVING PARTS TO COME TO A COMPLETE STOP.** Set the parking brake. Always remove the ignition key before beginning maintenance.

WARNING! For your own personal safety, **ALWAYS** mow **ACROSS** the face of slopes and **NEVER UP and DOWN** the face. **NEVER** attempt to mow excessively steep slopes, and use caution when turning on any slope.

Safety Alert Symbol



This Safety Alert Symbol means: **“ATTENTION! BECOME ALERT! YOUR SAFETY IS INVOLVED!”**

This symbol is used to call attention to safety precautions that should be followed by the operator to avoid accidents. When you see this symbol, carefully read the message that follows and heed its advice. Failure to comply with safety precautions could result in death or serious bodily injury.

Safety Signs

The signal words **DANGER**, **WARNING**, and **CAUTION** are used on the equipment safety signs. These words are intended to alert the viewer to the existence and the degree of hazard seriousness.



White letters on **RED**

This signal word indicates a potentially hazardous situation which, if not avoided, will result in death or serious injury.



Black letters on **ORANGE**

This signal word indicates a potentially hazardous situation which, if not avoided, could result in death or serious injury.

It may also be used to alert against unsafe practices.



Black letters on **YELLOW**

This signal word indicates a potentially hazardous situation exist which, if not avoided, will result in minor or moderate injury.

It may also be used to alert against unsafe practices.

PECO LIMITED WARRANTY FOR NEW PRODUCTS

A. WHAT IS WARRANTED?

PECO extends the following warranties to the original purchaser of each new PECO consumer product subject to the following limitations:

- 1. PRODUCT WARRANTY:** Any part of any consumer product, which is defective in material or workmanship as delivered to the purchaser will be repaired or replaced, as PECO elects, without charge for parts or labor, if the defect appears within 12 months from the date of delivery of the product to the original purchaser. **ALL DEFECTIVE PARTS MUST BE RETURNED TO PECO FOR INSPECTION TO DETERMINE VALIDITY OF WARRANTY CLAIMS.** Freight and mailing will be borne by the customer.
- 2. PARTS REPLACED DURING WARRANTY:** Any new PECO part which is furnished in performance of this warranty and is defective in material or workmanship as delivered to the purchaser will be repaired or replaced, as PECO elects, without charge if the defect appears within 90 days from the date of installation of such part or before the expiration of the original warranty period, whichever is later.

B. SECURING WARRANTY ADJUSTMENTS.

Call PECO for Return Authorization. Damaged or broken parts, other than engines or batteries, must be returned to PECO Inc., 100 Airport Road, Arden, NC 28704 before any warranty adjustment can be authorized. At the time of requesting warranty adjustment, the purchaser must present evidence for date of delivery of the product. The purchaser shall pay any charge for the product to and from Arden, NC.

C. ITEMS NOT COVERED BY PECO WARRANTY.

Engines and batteries attached to PECO products are covered under a separate warranty by the respective manufacturer.

D. UNAPPROVED ALTERATION OR MODIFICATION.

All obligations of PECO Inc., under this warranty, shall be terminated if products are altered or modified in ways not approved by PECO Inc..

E. ACCIDENTS AND NORMAL MAINTENANCE.

The warranty covers only defective material and workmanship. It does not cover depreciation or damage caused by normal wear, accident, improper use or abuse of products. The cost of normal maintenance and normal replacement of service items such as belts, cutting blades, hoses, etc., which are not defective shall be paid for by the purchaser.

F. NO REPRESENTATIONS ADDITIONAL WARRANTIES, DISCLAIMER.

Neither PECO Inc. nor any company affiliated with it makes any warranties, representations or promises as to the quality of performance of its products other than those set forth herein. Except as described above, PECO Inc. makes no other warranties **AND SPECIFICALLY DISCLAIMS ANY AND ALL IMPLIED WARRANTIES OF FITNESS AND MERCHANTABILITY.**

G. ANY MACHINE USED FOR RENTAL PURPOSES ARE GUARANTEED FOR 45 DAYS FROM DATE OF ORIGINAL SALE ONLY.

H. REMEDIED EXCLUSIVE.

The only remedies the purchaser has in connection with the breach or performance of any warranty on PECO Inc. consumer products are set forth above. In no event will PECO be liable for special incidental or consequential damages.

1. NO SERVICE CENTER WARRANTY.

The selling Service Center makes no warranty on his own on any item warranted by PECO Inc. unless he delivers to purchaser a separate written warranty certificate specifically warranting the item. The dealer has no authority to make any representation or promise on behalf of PECO or to modify the terms of this warranty in any way.

SECTION I

INTRODUCTION AND DESCRIPTION

1-1 Introduction

We are pleased to have you as a PECO customer. Your collection system has been designed to give you a low maintenance, simple and effective way to collect the grass clippings from your mower. This manual is provided to give you the necessary instructions to properly mount and operate the collection system on your mower. Please read this manual thoroughly. Understand what each control is for and how to use it. Observe all safety decal precautions on the machine and noted throughout the manual.

Note: All references made to right, left, front, rear, top or bottom are as viewed from the normal operator's position on the mower.

1-2 Description

The collection system is designed for turf maintenance where there is a need to collect the grass clippings as the mower cuts the turf. It is also good for picking up leaves and twigs in pre-season and post-season clean-up.

The engine/blower/blade assembly, is mounted on the right side of the unit. The blower draws grass clippings from the discharge area of the cutter deck up to the aluminum container mounted over the rear portion of the frame. The operator can engage the engine/blower/blade assembly by starting the engine.

Once the container is full of clippings, the operator can easily push and raise the lift handle, releasing the container's rear door and the container will pivot towards the ground.

Section II

PREPARATION FOR USE

2-1 Preparation Of Mower

Carefully dismantle wooden shipping crate from around the components. Cut retaining straps and separate the parts. The collection system will have various parts located inside. Remove and sort all parts for easy identification.

Note: Before each step of assembly it will help to study the exploded drawings on pages 13 thru 15.

Rotating The Donaldson Air Cleaner

Note: If equipped with a Donaldson air cleaner, unit must be rotated to make clearance for top main frame assembly. To rotate Donaldson air cleaner, loosen bolt on air cleaner bracket, rotate air cleaner forward as needed for clearance as shown in Figure 2-1a and tighten.

Figure 2-1a

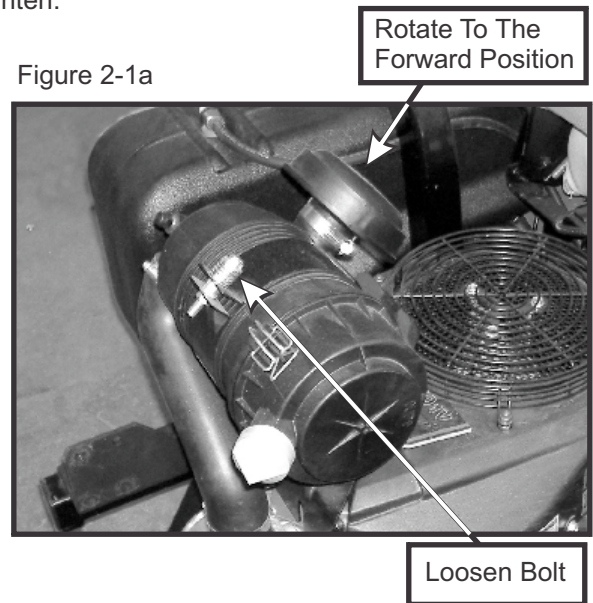

2-2 Lower Main Frame Leg Installation

Looking from the rear of mower, locate the ROPS mounting bolts and remove the lower hex bolt and washer from each side of the ROPS. On the mowers rear bumper, locate the slotted hole on each side. See Figure 2-2a.

Figure 2-2a

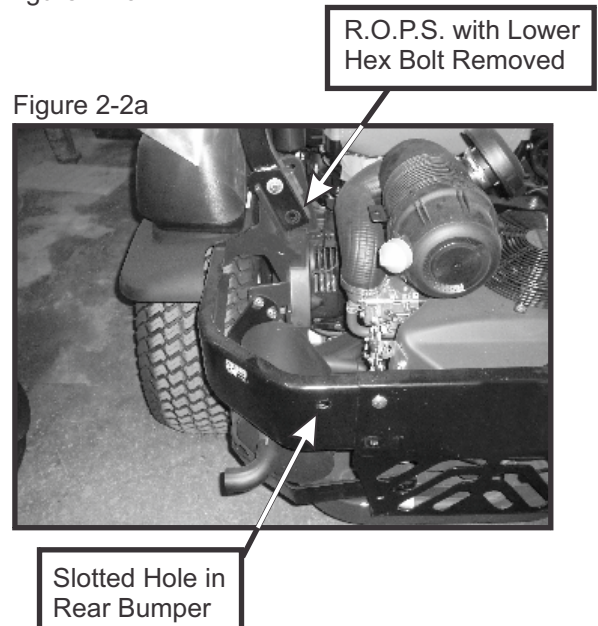

2-2 Lower Main Frame Leg Installation Cont...

From the rear of the mower, align each lower main frame leg, P#(B0528 Right) and P#(B0529 Left), to the lower ROPS mounting holes and to the rear bumper slot holes. Fasten to the lower ROPS mounting hole with existing hex bolt and washer removed in section 2-3a. Fasten to the rear bumper slotted hole by using (1) 1/2"-13 x 1" HHCS P#(K1231), (1) 1/2" flat washers P#(K0055) and (1) 1/2"-13 nyloc nut P#(K1247) per side. Refer to Figure 2-2b and 2-2c.

Figure 2-2b

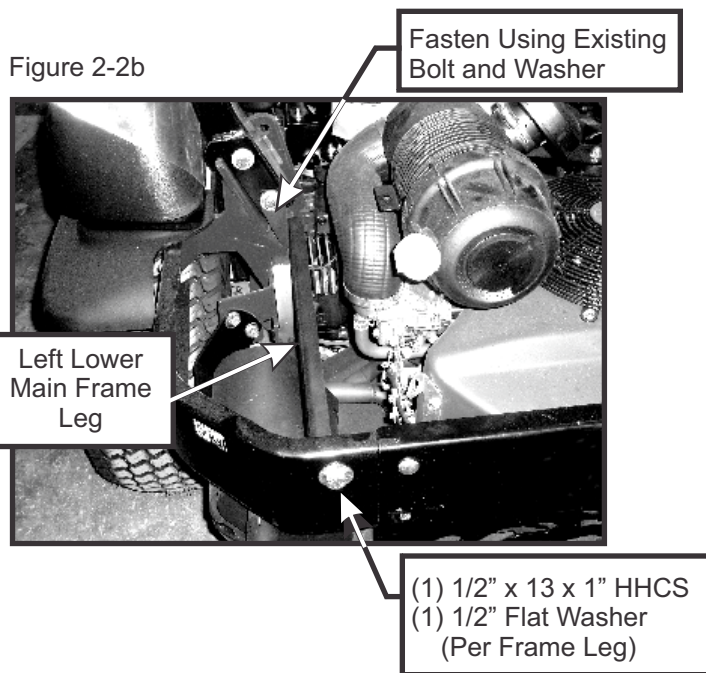
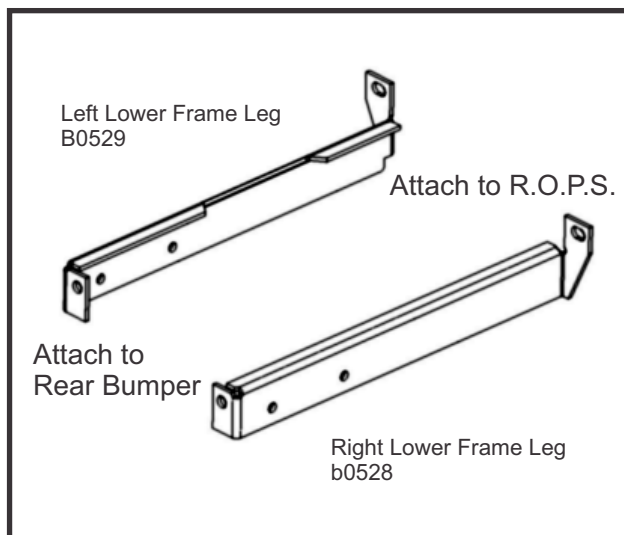

Figure 2-2c



2-3 Outer Engine Mount Tube Assembly Installation

Remove the lower 4 existing bolts from the rear heat guard as shown in Figure 2-3a. Align the holes of the outer engine mount tube assembly P#(A0605) to the holes on the heat guard and fasten by using (4) 3/8"-16 x 1" Carriage bolts P#(K1182) and (4) 3/8"-16 Nyloc Nuts P#(K1216). See Figure 2-3b.

Figure 2-3a

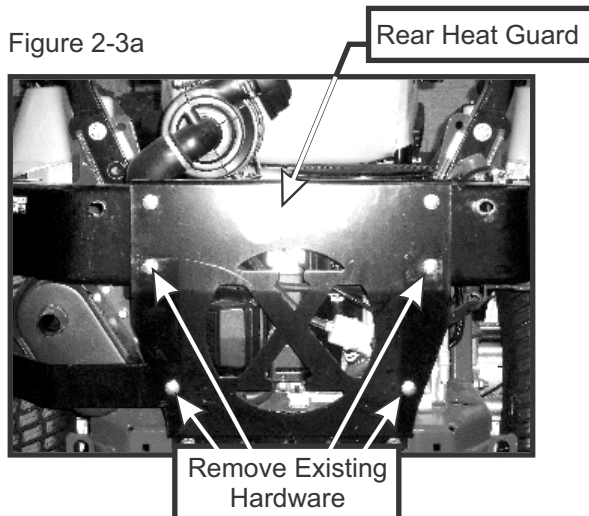
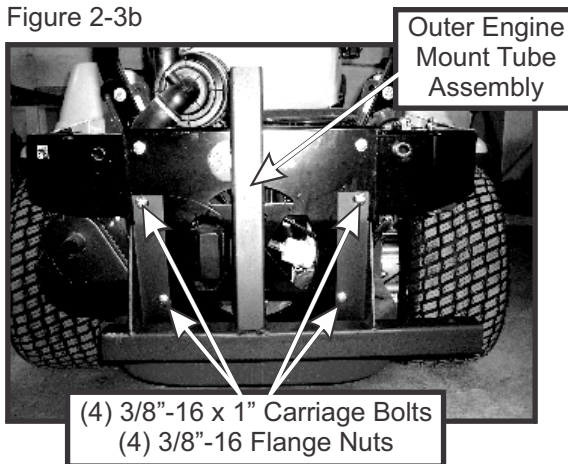

Figure 2-3b



2-4 Lower Mount Clamp Bracket Installation

Mount the lower mount clamp bracket P#(B0302) to the outer engine mounting tube using (1) 3/8" - 16 x 3.5" U-bolt P#(K0136) and (2) 3/8" - 16 nyloc nuts P#(K1216). Place U-bolt on the outside of the outer engine mount tube and place the mount clamp bracket to the inside of the rear bumper of mower. Align holes in bracket with U-bolt threaded ends and fasten with (2) 3/8"-16 nyloc nuts. See Figure 2-4a and 2-4b for reference.

2-4 Lower Mount Clamp Bracket Installation Cont...

Figure 2-4a Inside View

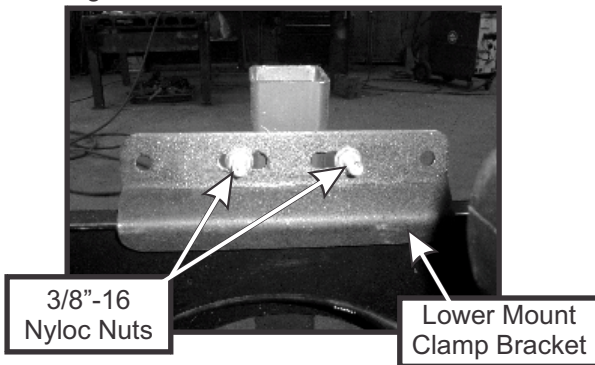
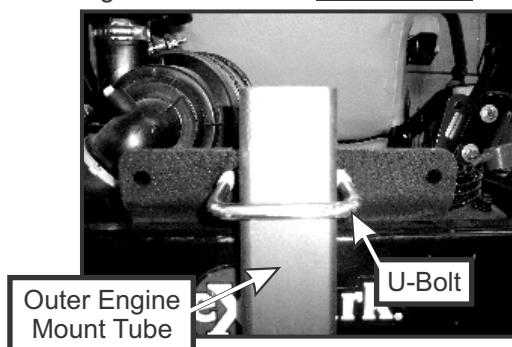

Figure 2-4b Outside View



2-5 Exhaust Diverter Installation

An exhaust diverter is required to prevent exhaust from blowing on the collection bags. Fasten the exhaust diverter P#(J0251) to the existing exhaust muffler on left rear side of the mower using (1) exhaust clamp P#(X1046). Refer to Figure 2-5a and 2-5b.

Figure 2-5a

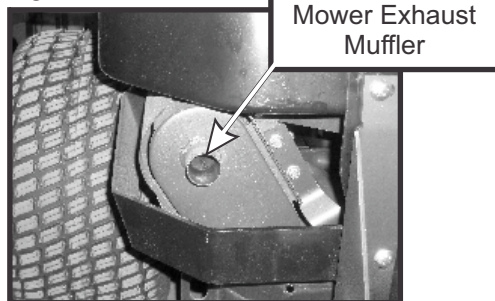
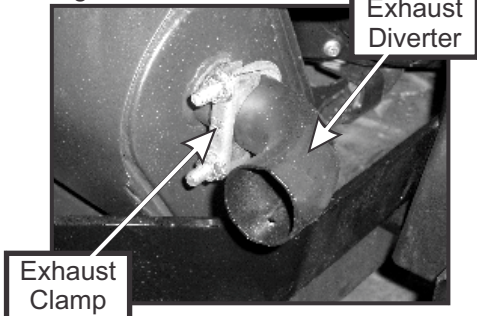

Figure 2-5b



2-6 Exhaust Deflector Plate Installation

An exhaust deflector plate is required to prevent exhaust diverter from touching the collection bags. Fasten the exhaust deflector plate P#(C0061) to the bumper on the left rear side of the mower using the existing hex bolt (step 2-2a, page 5) used to mount lower main frame leg. Refer to Figure 2-6a.

Figure 2-6a

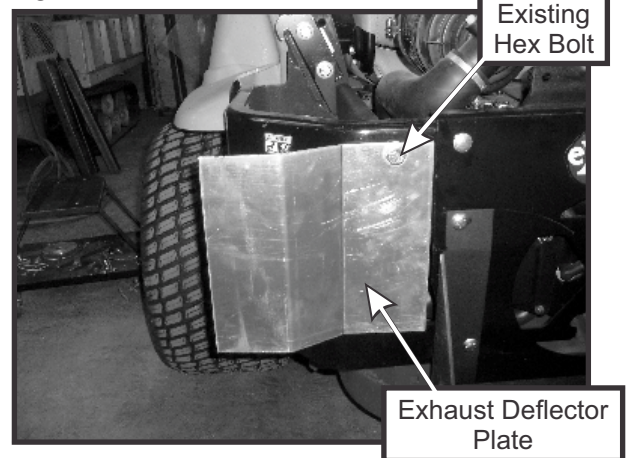

2-7 Upper Frame Assembly Installation

NOTE: During this step, it is suggested that two people install the upper frame to the lower mount tube.

Using (2) people to lift the upper frame, lift the upper frame assembly P#(A0585) above the outer engine mount tube assembly P#(A0605) making sure the frame is pointing away from the mower. Slide the upper frame tube into the outer engine mount tube assembly aligning the mounting hole. Insert (1) 1/2" x 2-1/2" clevis pin P#(K0133) through the hole and fasten with (1) 5/32" x 2-5/8" hair pin clip P#(K0088). Refer to Figure 2-7a thru Figure 2-7c.

Figure 2-7a

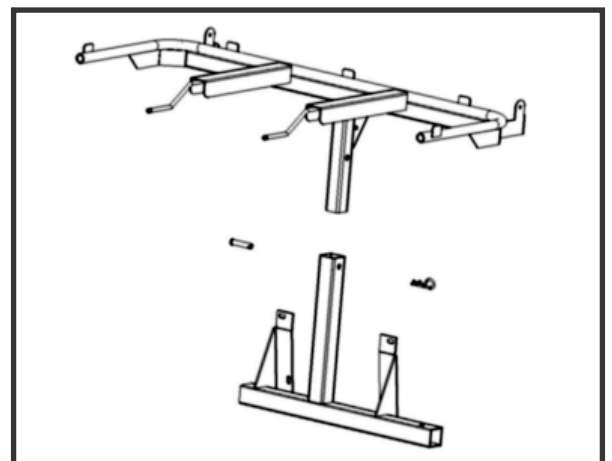

2-7 Exhaust Deflector Plate Installation Cont...

Figure 2-7b

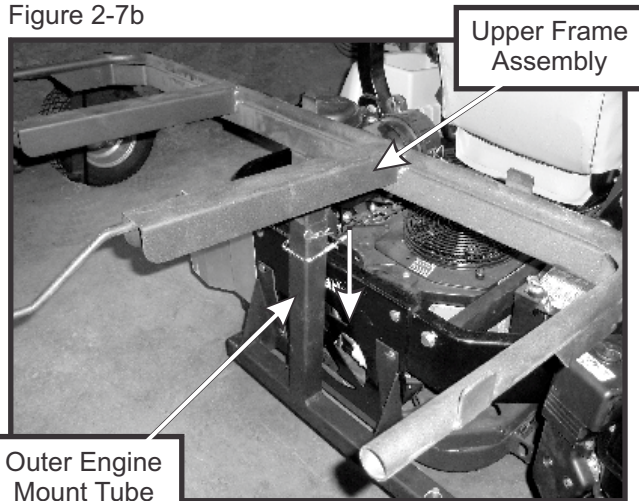

Outer Engine Mount Tube Assembly

Figure 2-7c

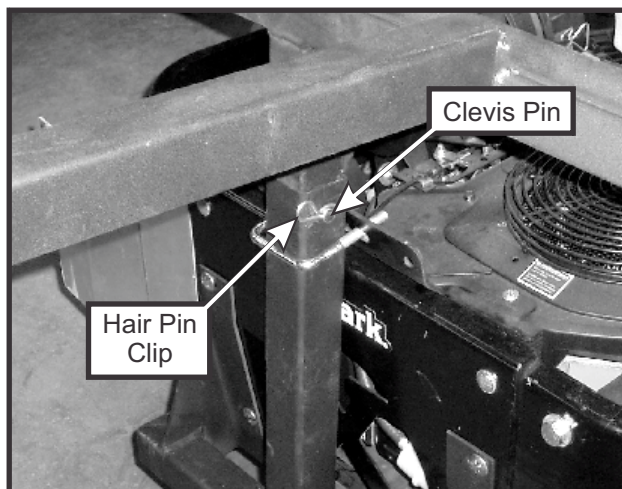

2-8 Top Assembly To Upper Frame Assembly Installation

Align the pivot brackets of the top assembly P#(A0551) to the pivot point on either side of the upper frame assembly. Place (1) fender washer P#(K0041) between pivot point (Figure 2-8a) and fasten by using (1) P#(K1153) 5/16"-18 x 3/4" HHCS and (1) 5/16"-18 nyloc nut P#(K1180). Repeat steps for other side. When fastening leave nut slightly loose so that the top can pivot freely. Refer to Figures 2-8a and 2-8b.

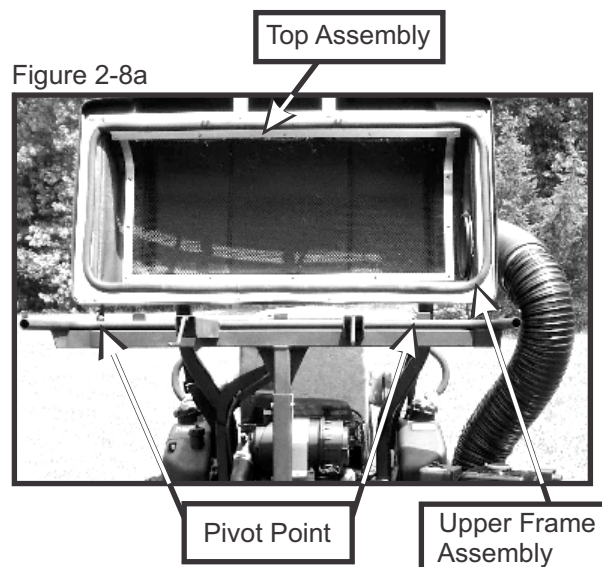
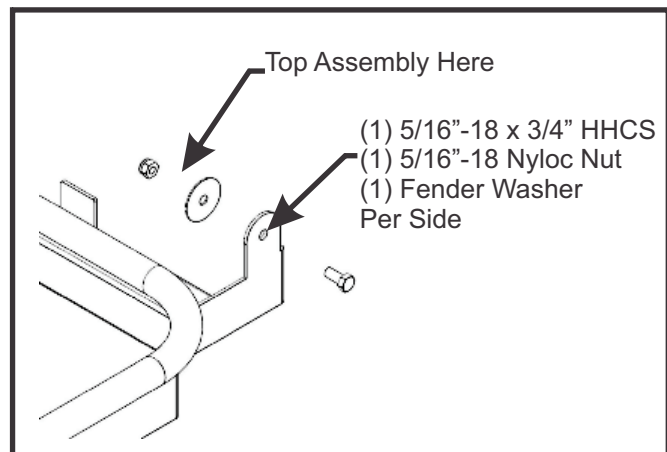

Figure 2-8a

Figure 2-8b.



2-9 Deck Pulley Installation

Remove the grass deflector shield from the grass discharge on the mowers deck. Remove the existing spindle cover and hardware from the deck pulley. Figure 2-9a.



Stop unit, shut off deck attachment, set parking brake, shut off mower engine and remove spark plug wire before installing parts to the mower.

Do not work around the mower deck, PTO deck drive or the blower area until you are certain that the mower blades and the blower impeller have stopped rotating.

2-9 Deck Pulley Installation Cont...

Figure 2-9a

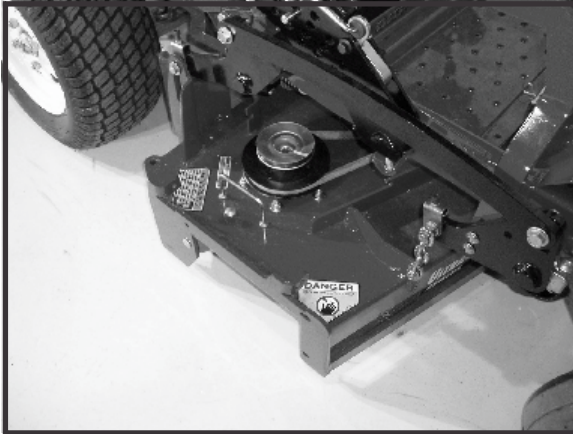

Remove the bolt and hardware from the existing pulley and place the pulley assembly P#(A1057) on top of the existing deck pulley. Fasten both pulleys to the deck using the existing hardware removed from the original deck pulley. Figure 2-9b.

Figure 2-9b

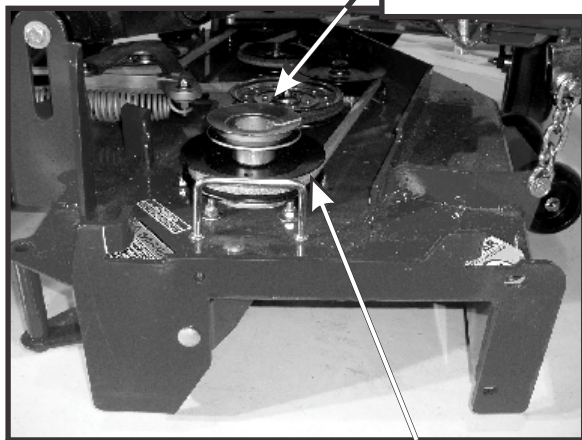

Existing Pulley Assembly

2-10 Deck Drive Assembly Installation



Stop unit, shut off deck attachment, set parking brake, shut off mower engine and remove spark plug wire before installing PTO Deck Drive Assembly.

Do not work around the mower deck, PTO deck drive or the blower area until you are certain that the mower blades and the blower impeller have stopped rotating.

The deck drive assembly P#(A1055) will mount to the flanges on the discharge side of the mower deck where the grass deflector was removed in Section 2-9. The mounting brackets on the deck drive assembly slide down onto the existing brackets that held the grass deflector on the mower deck. The deck drive assembly is secured with (1) mount rod P#(B8168) which is placed through the holes in the deck brackets and the holes in the deck drive assembly bracket. Secure rod with (2) hair pin clips P#(K0099). There is a hole in each end of the mount rod. Place one hair pin clip in each hole. This holds the deck drive assembly in place. Figures 2-10a thru 2-10c.

Grass Deflector Brackets

Figure 2-10a

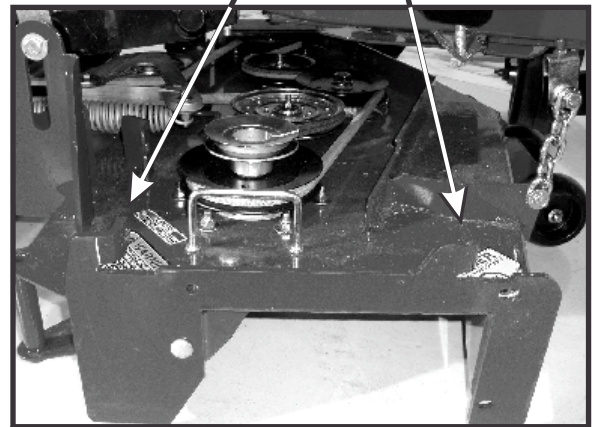

Deck Drive Assembly

Figure 2-10b

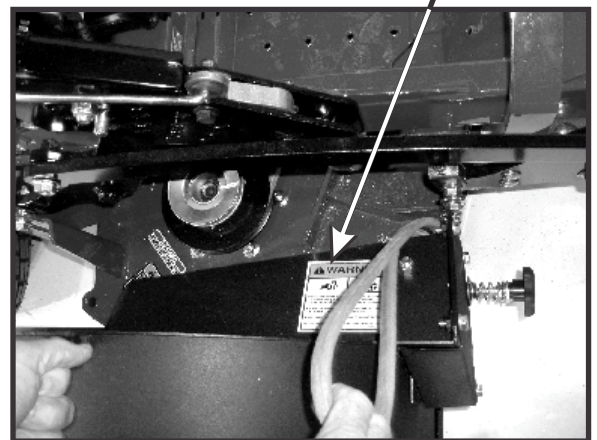

2-10 Deck Drive Assembly Installation Cont...

PTO Deck Drive Bracket

Figure 2-10c

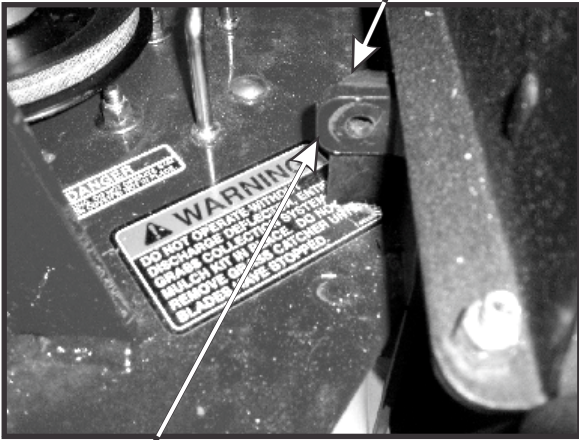

Deck Bracket

Hair Pin Clip

Figure 2-10d

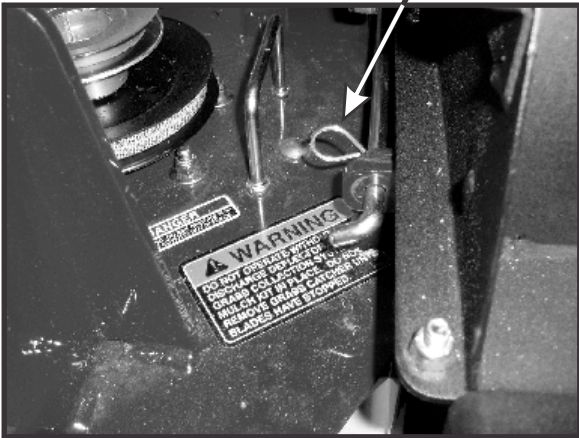
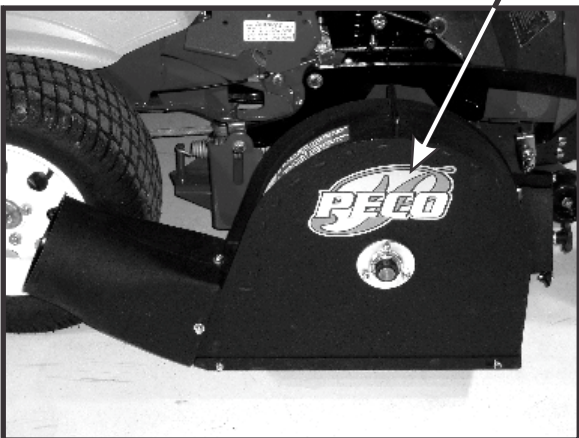

Figure 2-10e

Deck Drive Assembly



2-11 Belt Installation

NOTE: 48" DECK USES BELT P#(M0251)

NOTE: 52" DECK USES BELT P#(M0306)

Wrap the belt around the top deck pulley (A1057) previously installed in Section 2-10. Wrap the other end of the belt around the deck drive pulley P#(A1055) installed in Section 2-9. Refer to Figures 2-11a and 2-11b.

Figure 2-11a

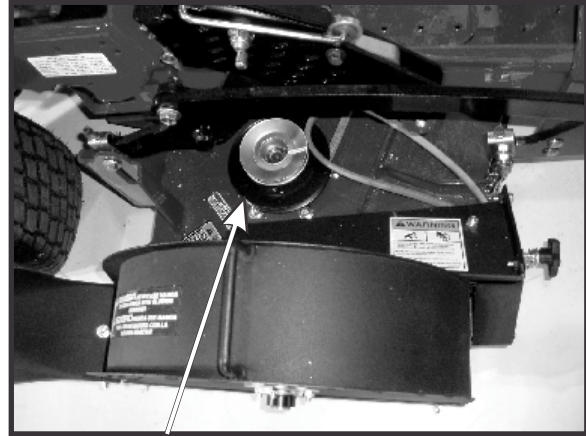

Blade Drive Pulley

Figure 2-11b

Engine Pulley (Inside)

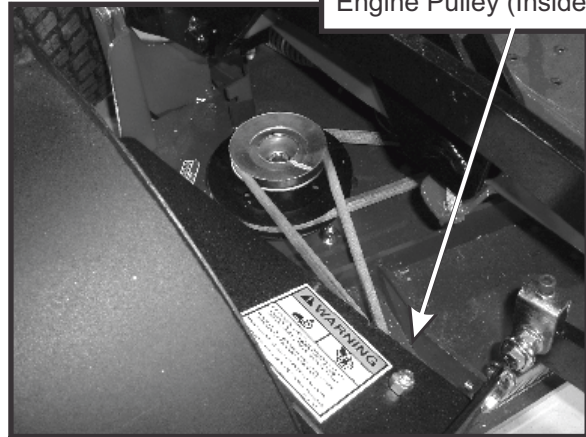

Note: The belt tension may need to be adjusted to properly install the belt to both pulleys. To tension the drive belt, turn the tension adjustment knob clockwise until there is 1" of deflection with 10-11lbs of pressure between the deck pulley assembly and the deck drive idler pulley. Refer to Figure 2-11c and 2-11d.

2-11 Belt Installation Cont...

Proper Tension:
1" Of Deflection for 10-10lbs of Pressure Applied
To Center of belt

Figure 2-11c

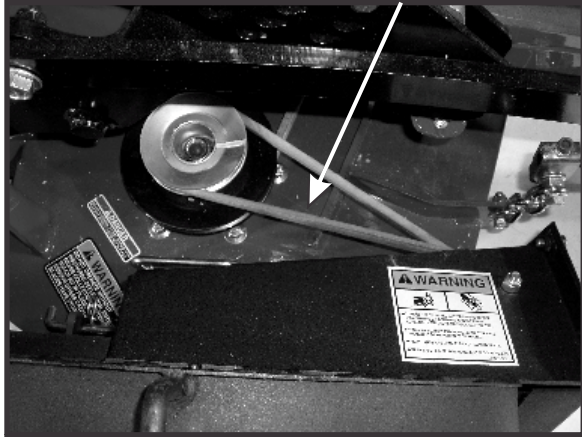
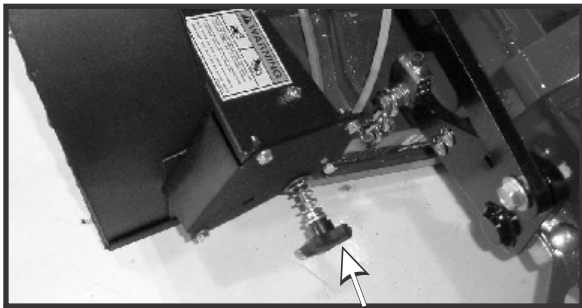

Figure 2-11d



Tension Adjustment Knob

2-12 Pulley Guard Installation

Place the PTO pulley guard P#(A1751) over the deck pulley while inserting the tab into the slot on the deck drive assembly. Figure 2-12a and 2-12b.

Mount the Pulley Guard Clamp. It is used to hold the pulley guard in place. Align the hole in the pulley guard clamp P#(B0586) with the bolt on the engine pulley guard. Pulley guard clamp should be placed to the outside of the mower deck U-bolt. Figure 2-12c thru 2-12e.

Figure 2-12a

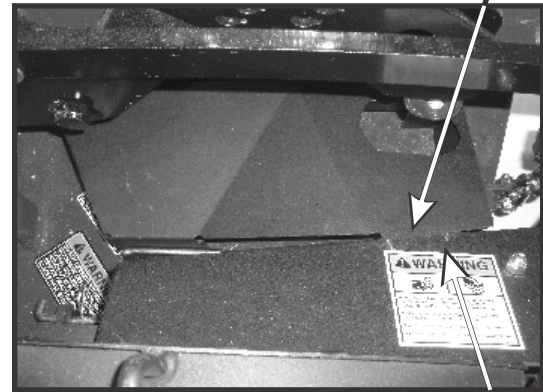

Pulley Guard Tab

Deck Drive Assembly Slot

Figure 2-12b

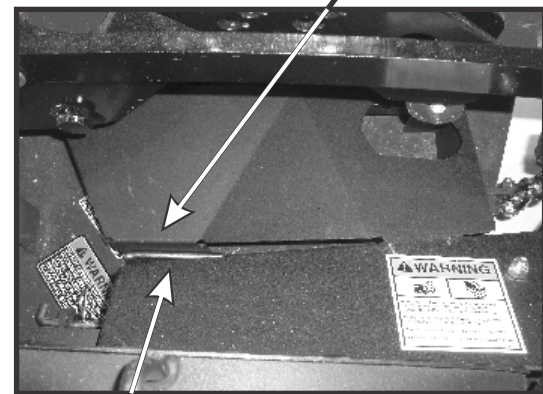

Pulley Guard Flange

Mower Deck U-bolt

Figure 2-12c

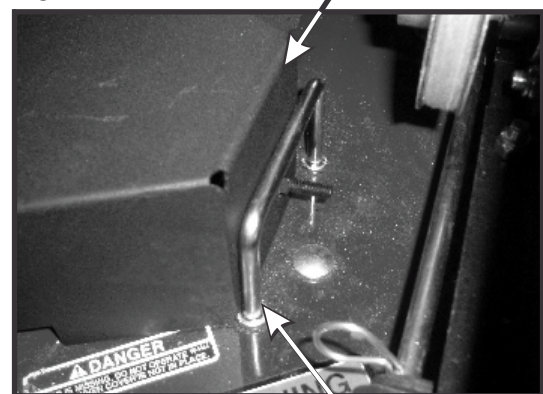

Engine Pulley Guard

Mower Deck U-bolt

2-12 Pulley Guard Installation Cont...

Figure 2-12d

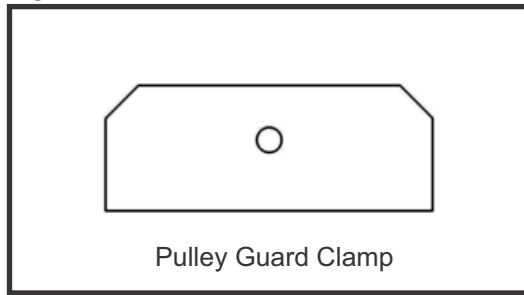

Pulley Guard Clamp

Figure 2-12e

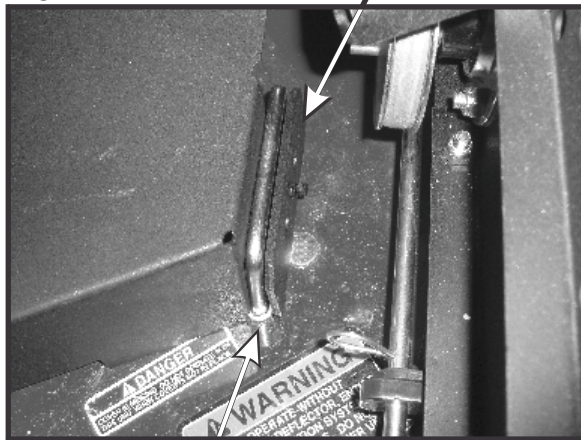

Secure pulley guard clamp with (1) 5/16"-18 star knob P#(J0256). Figure 2-12f and 2-12g.

5/16"-18 Star Knob

Figure 2-12f

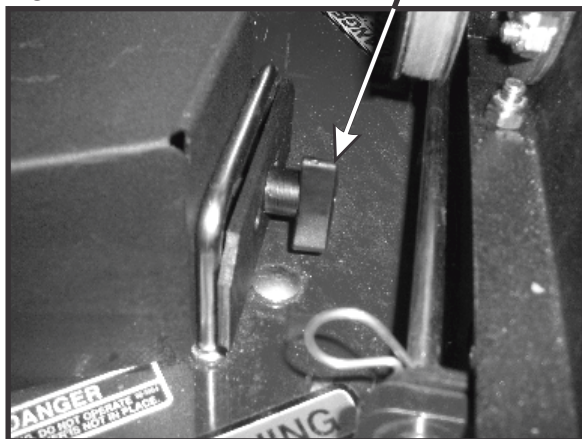
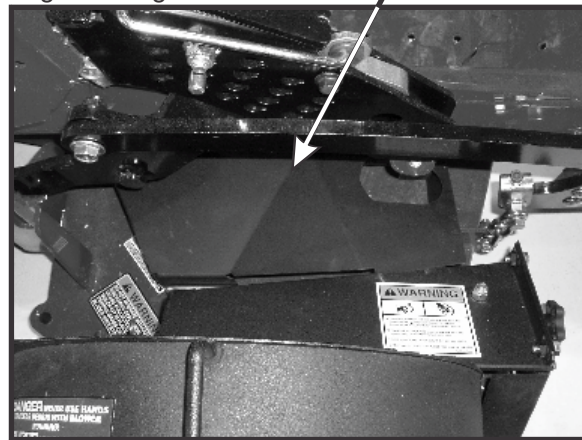

Figure 2-11g



2-13 Inlet and Hose Installation

With the top assembly P#(A0551) in the upright position, insert the inlet P#(V1054) into the right hand hole in the top assembly as shown in Figure 2-13a. Continue to insert the inlet until it snap locks into place. The inlet should now pivot freely about the hole.

Slide (1) upper hose clamp P#(J1000) onto both ends of the 7" hose. Slide one end of the 7" hose onto the inlet. Make sure there is about a two-inch overlap between the hose end and the container inlet. Proceed to slide the opposite end of the 7" hose onto the outlet of the PTO deck drive assembly and tighten hose clamp. See Figure 2-13a and 2-13b for details. Make sure both ends of the hose are clearly attached to the inlet and the outlet of the deck drive assembly. Tighten the hose clamps.

Figure 2-13a

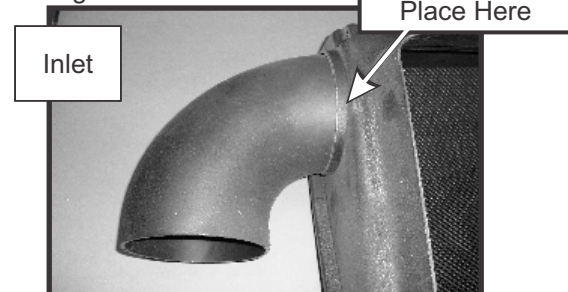
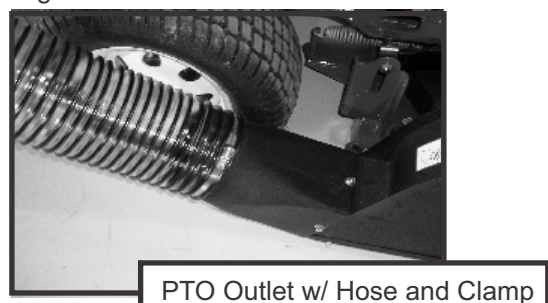

Figure 2-13b



2-14 Installation/Removal Of Collection Bags

To install the bag onto the bag ring, first make sure the bag ring end caps are fastened to the bag ring. Place the seam openings of the bag onto the bag ring openings and turn the bag until the slot bracket in the bag ring is protruding from the opening in the bag (Figure 2-14a). Do this for each of three bags.

Install the completed assemblies onto the support frame and close the plastic top. Fasten both draw latches to hold the plastic top closed (Figure 2-14b).

To empty the bag, remove the bag and bag ring by lifting and sliding rearward. Grasp the loop on the bottom of the bag, turn it upside down and empty the collected debris (Figure 2-14c). Repeat for the other bags. Reinstall all bags, line with plastic bags if desired, close the plastic top and reattach the draw latches.

Plastic lawn and leaf bags, 33 gallon size, may be used inside the cloth bags. Be sure to leave enough plastic bag hanging over the frame so the plastic bags can be twist tied before emptying (Figure 2-14d).

Figure 2-14a

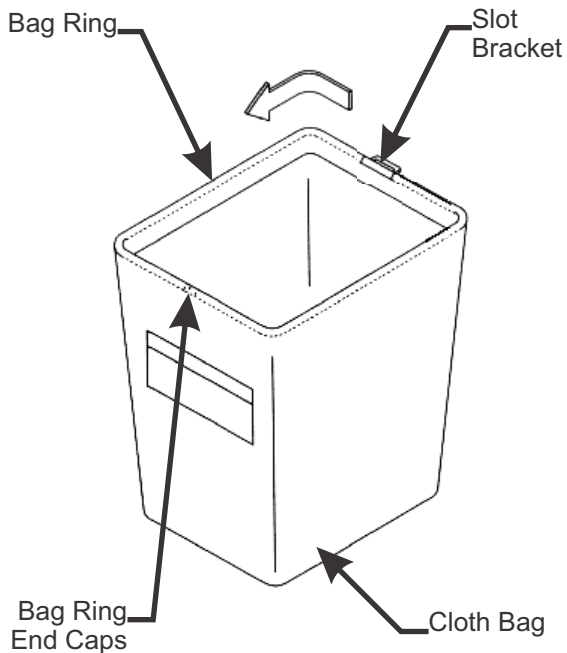

Figure 2-14b

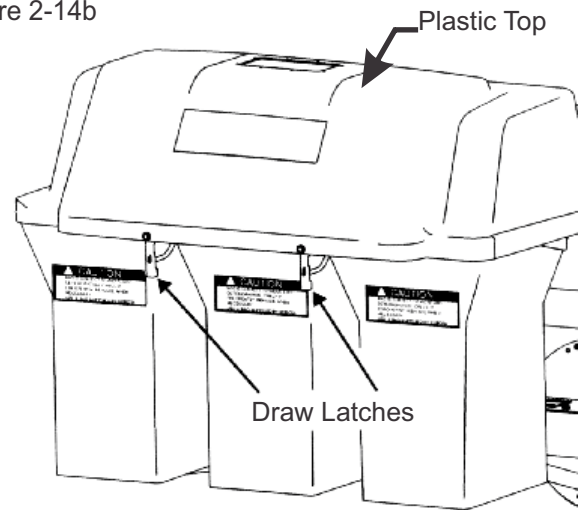
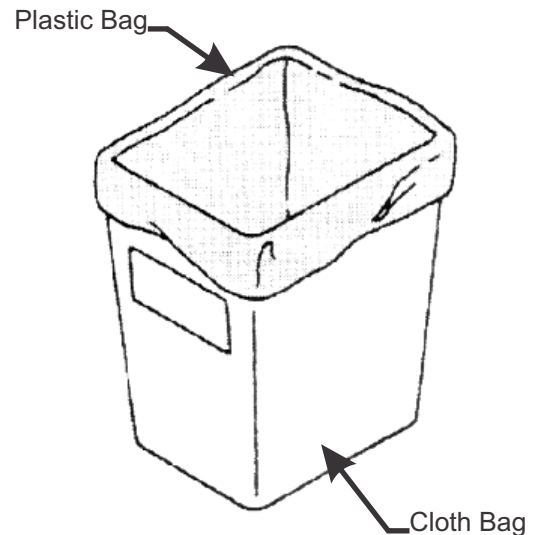

Figure 2-14c



Figure 2-14e



2-15 Front Weight Assembly Installation

Place (1) weight bracket P#(B0026) over each front caster. Fasten each weight bracket to the front caster loosely, by using (1) 3/8"-16 x 4" U-bolt P#(K1419) and (2) 3/8"-16 nyloc nuts P#(K1216) per bracket. When installing the weight you should have another person help position the weight. Lift the weight and place on top of the weight brackets. Fasten the weight to the weight brackets by using (1) 1/2"-13 U-bolt X 4 - 1/4" P#(K0331) and (2) 1/2"-13 nyloc nuts P#(K1247) per bracket. Once the weight is secure tighten all nuts. See Figure 2-15a for more detail.

Figure 2-15a

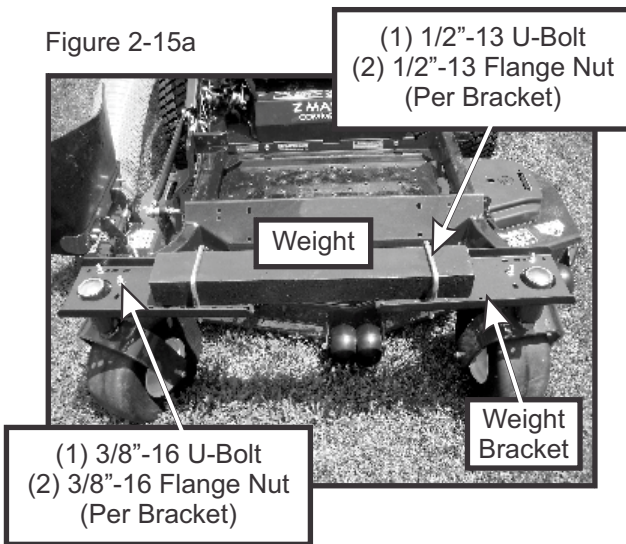

Exploded View Of The
A0551 - Bagger Assembly

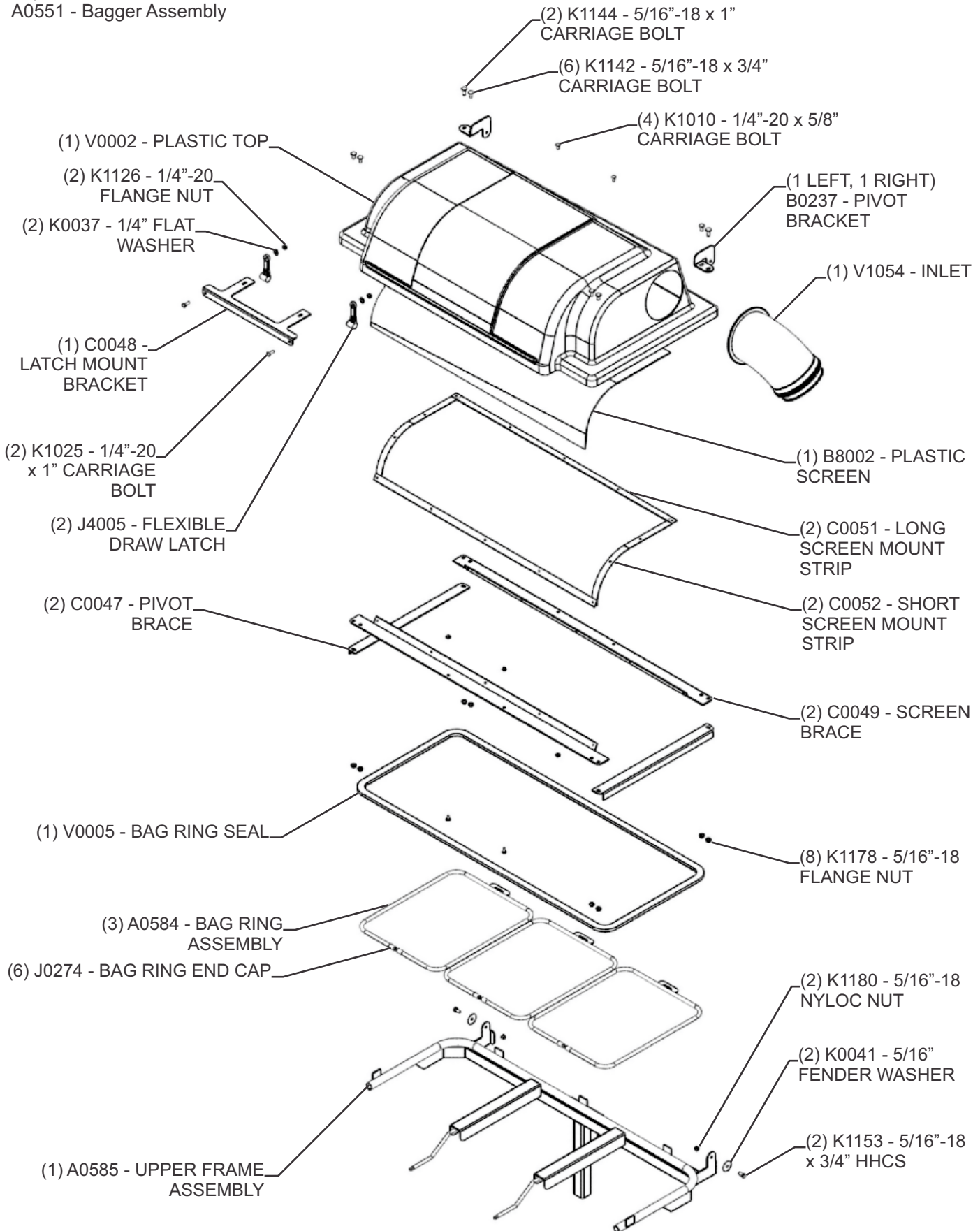

VIEW 1
A1055

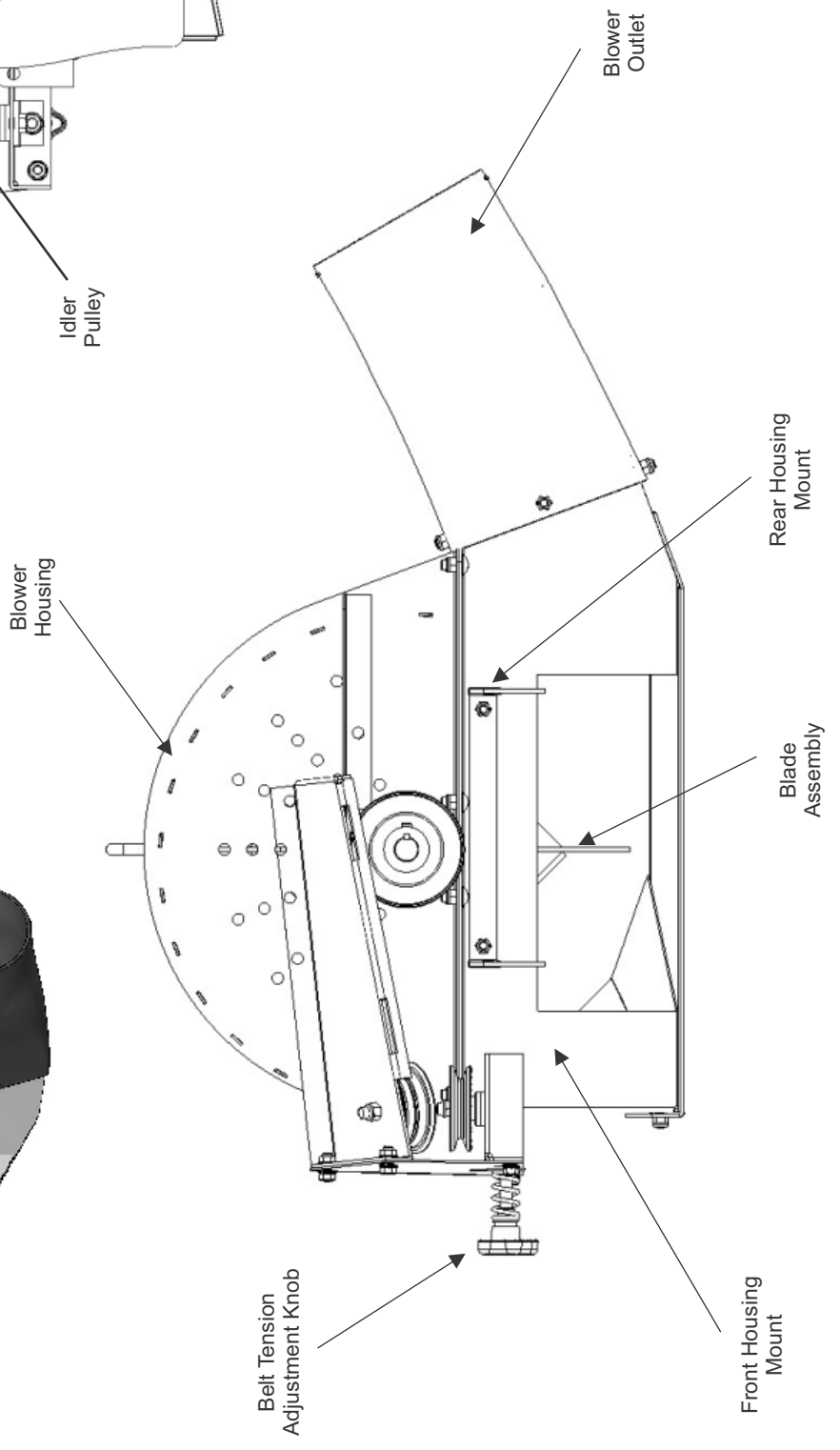
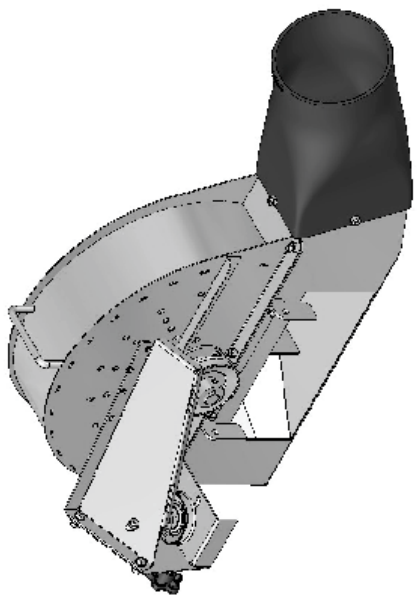
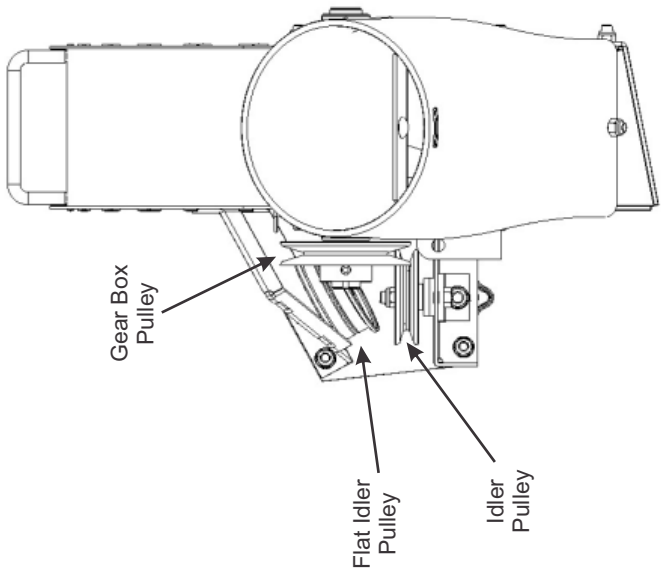

Belt Tension
Adjustment Knob

VIEW 2

A1055

Item Number	Document Number	Title	Quantity
1	V1164	7" BLOWER OUTLET	1
2	M0302	IDLER PULLEY	1
3	K1216	3/8"-16 NYLOC NUT	1
4	K1191	3/8"-16 x 1" HHCS	1
5	K1180	5/16"-18 NYLOC NUT	4
6	K1142	5/16"-18 x 3/4" CARRIAGE BOLT	4

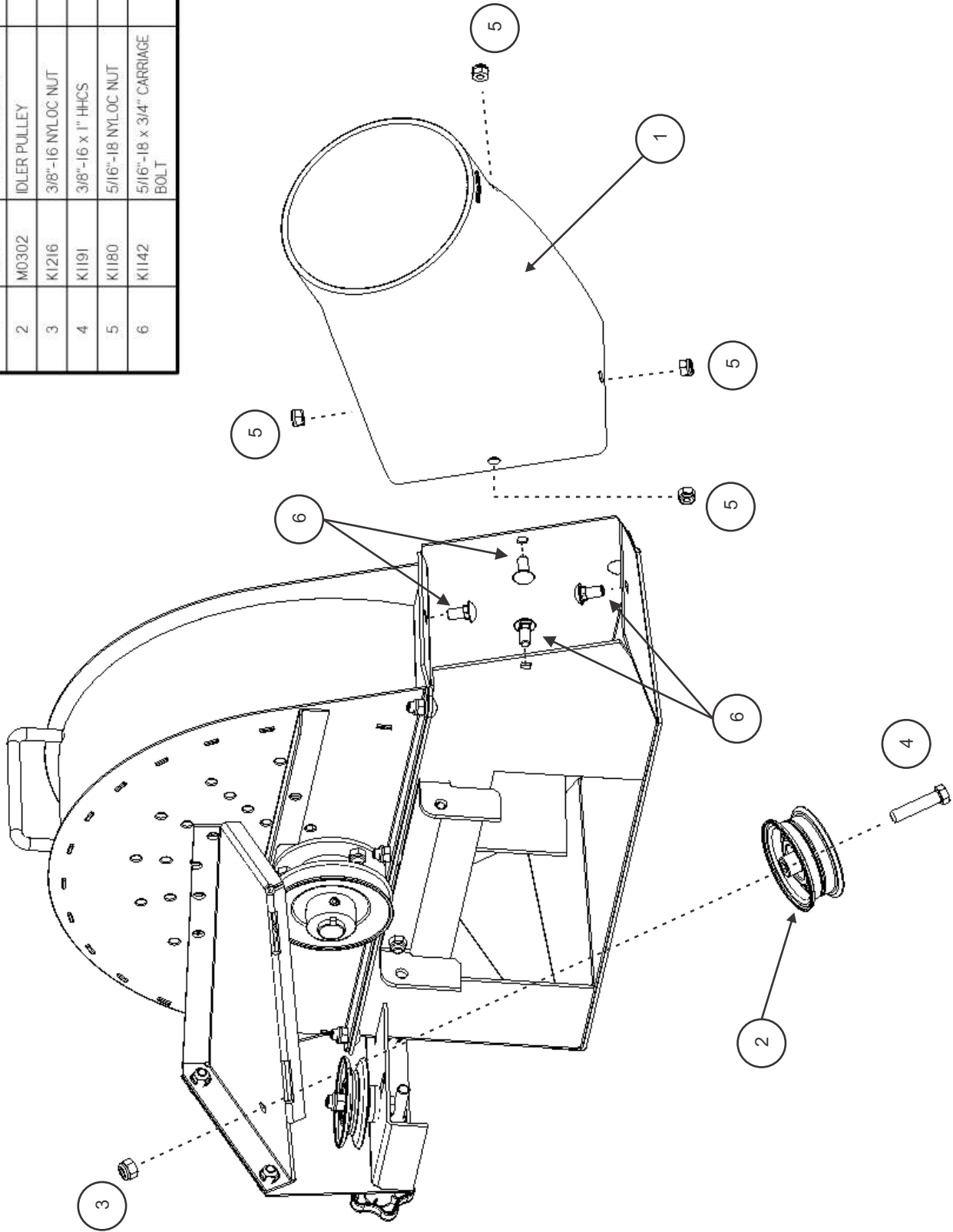

VIEW 3

A1096 / A1055 / A1733

Item Number	Document Number	Title	Quantity
1	M0303	IDLER PULLEY	1
2	B0554	IDLER PULLEY STIFFENER BRKT.	1
3	K1446	1.187 OD x .380 ID x .187 WASHER	2
4	K0058	5/8" FLAT WASHER	1
5	J4007	3/8"-16 STAR KNOB	1
6	K1216	3/8"-16 NYLOC NUT	2
7	K0042	5/16" FLAT WASHER .875 OD x .380 ID x .075 T	1
8	J0303	SPRING	1
9	K0406	IDLER PULLEY TENSION ROD	1
10	K1208	3/8"-16 x 2" HHCS	1
11	K0043	5/16" LOCK WASHER	4
12	K1153	5/16"-18 x 3/4" HHCS	4
13	B0553	IDLER PULLEY MNT. BRKT.	1
14	B0559	TENSION BUSHING	1
15	B0560	TENSION BRKT.	1

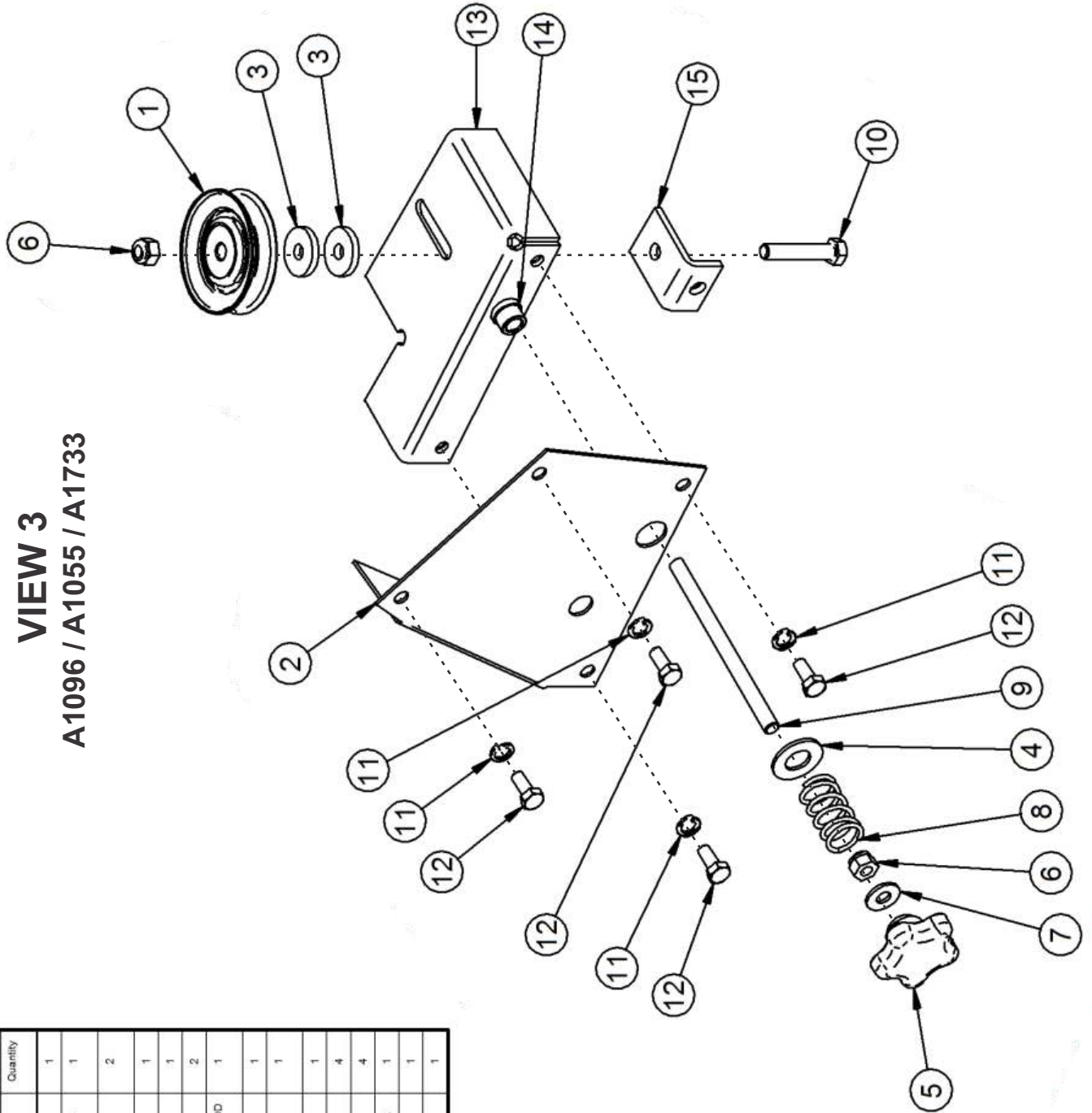

VIEW 4
A1055

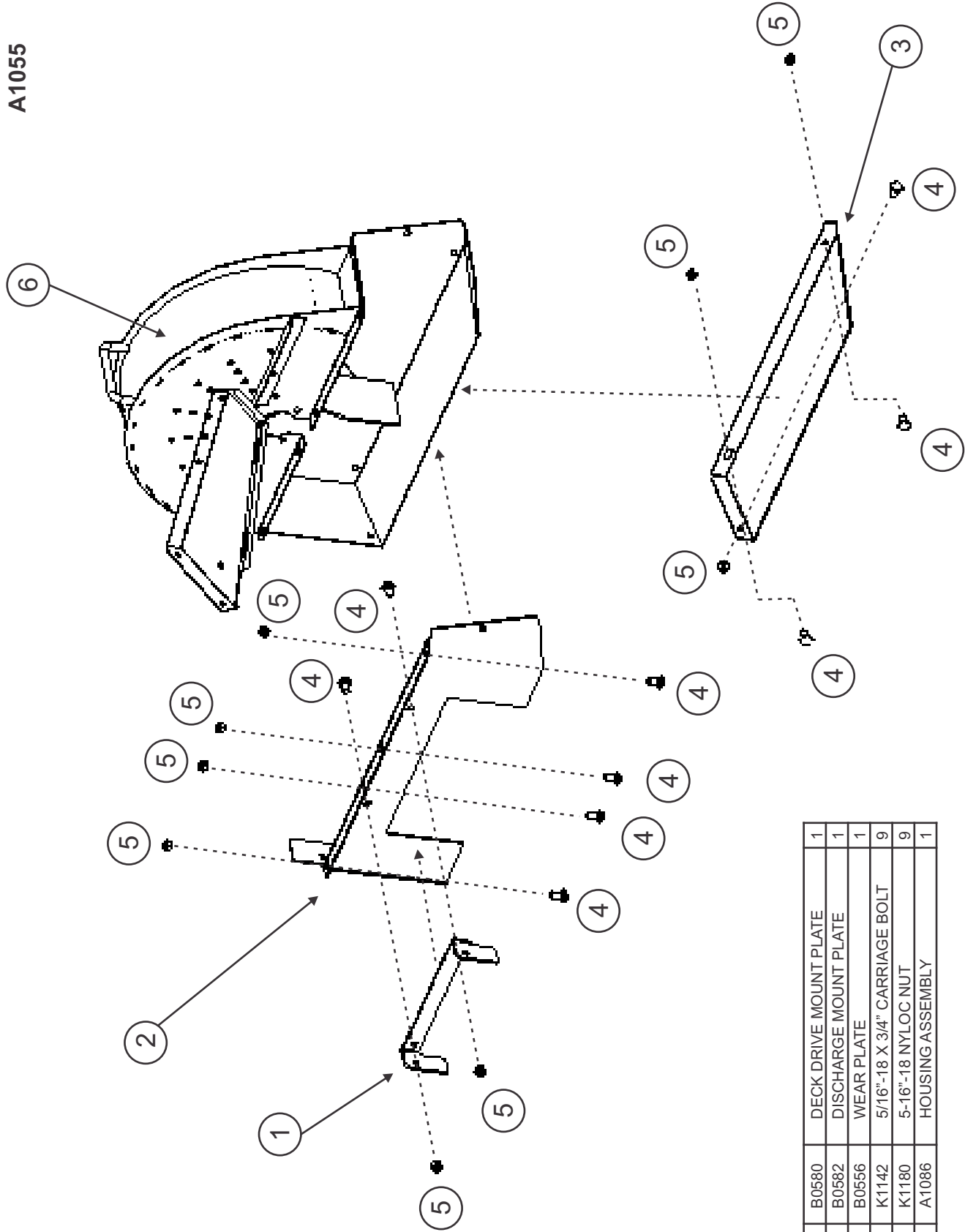

1	B0580	DECK DRIVE MOUNT PLATE	1
2	B0582	DISCHARGE MOUNT PLATE	1
3	B0556	WEAR PLATE	1
4	K1142	5/16"-18 X 3/4" CARRIAGE BOLT	9
5	K1180	5-16"-18 NYLOC NUT	9
6	A1086	HOUSING ASSEMBLY	1

1	K0075	3/16" SQUARE X 1" LONG KEYWAY	1
2	A0498	GEAR BOX PULLEY ASSEMBLY	1
3	K0035	5/16" - 18 SET SCREW	1
4	K1180	5/16" -18 NYLOC NUT	6
5	N0105	BROWNING MOUNTED BALL BEARING	2
6	B0541	LEFT HOUSING PLATE	1
7	K1142	5/16 -18 X 3/4" CARRIAGE BOLT	6
8	A1088	FAN BLADE ASSEMBLY	1
9	B0543	RIGHT HOUSING PLATE	1

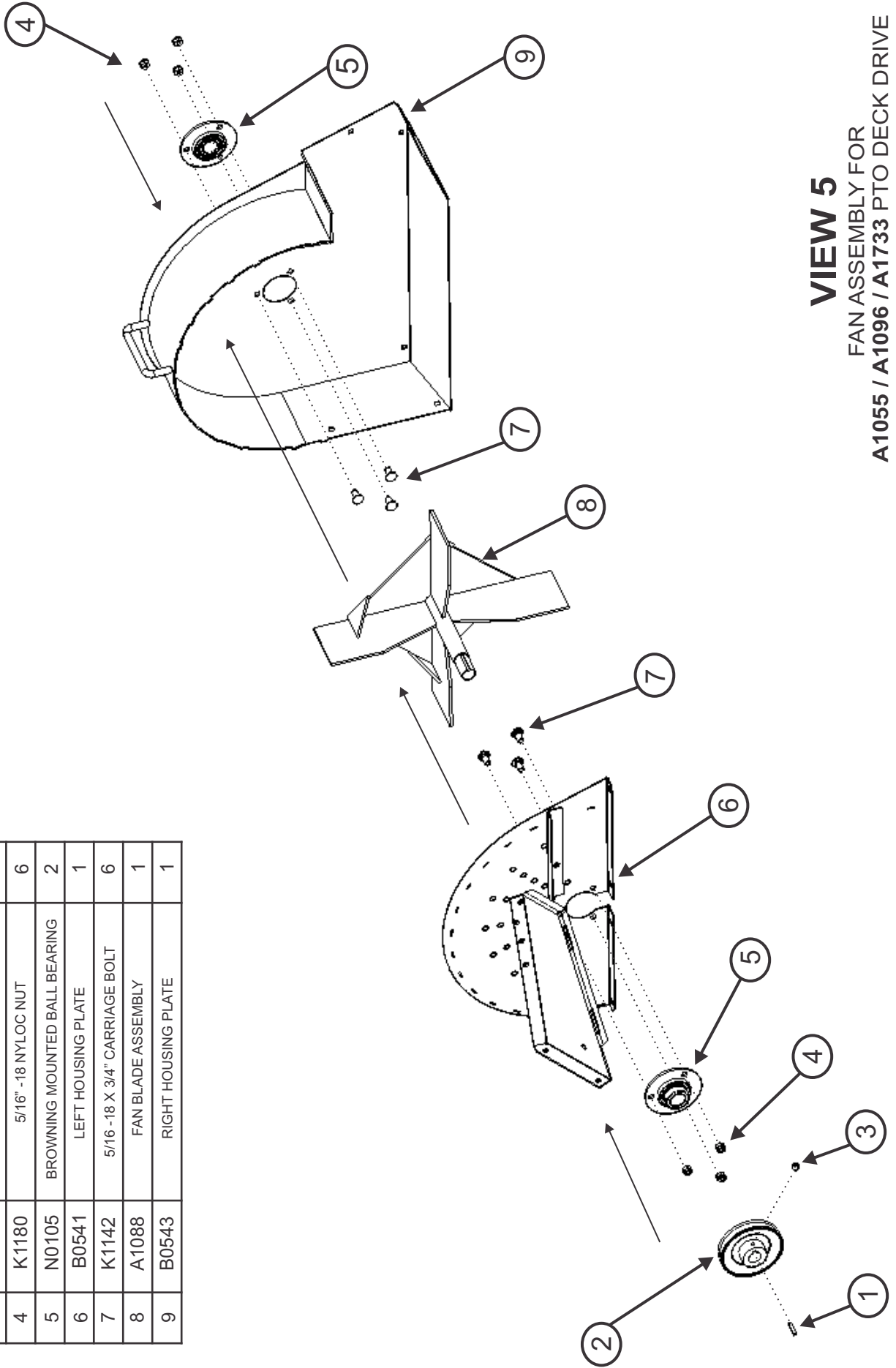

VIEW 5
 FAN ASSEMBLY FOR
 A1055 / A1096 / A1733 PTO DECK DRIVE

MODEL#: 35031503

MOWER NAME: EXMARK

MOWER MODEL: NEW GENERATION LAZER Z

MOWER DECK SIZE: 48"

VAC NAME: 15 CUBIC FOOT PRO BAGGER

DECK DRIVE

MANUAL: #Q0400

A1753 UNIT ASSEMBLY



FOR YEAR: 2010

REVISED:

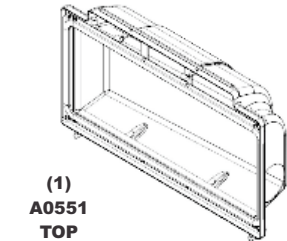

(1)
A0551
TOP
ASSEMBLY



(1)
V1054
6" PLASTIC
INLET



(1)
7" x 45"
UPPER
HOSE



(2)
J1000
HOSE CLAMPS



(1)
HB0406
HARDWARE
BAG

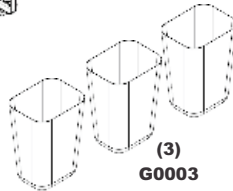

(3)
G0003
4 CU. FT.
COLLECTION
BAGS

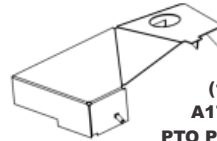

(1)
A1751
PTO PULLEY
GUARD
ASSEMBLY



(1)
M0261
A62K
KEVLAR
BELT

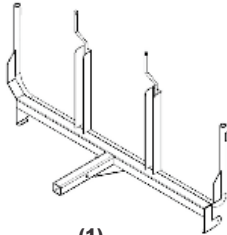

(1)
A0585
UPPER FRAME
ASSEMBLY



(1)
B8168
PTO DECK DRIVE
ASSEMBLY MOUNT ROD



(1)
B0586
PULLEY
GUARD CLAMP

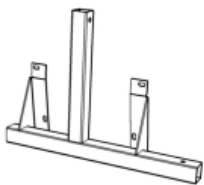

(1)
A0605
OUTER ENGINE
MNT. TUBE ASSY.



(3)
A0584
BAG RING
ASSEMBLY



(1)
B0302
LWR. MNT.
CLAMP BRKT.

A1055 - PTO DECK DRIVE ASSEMBLY

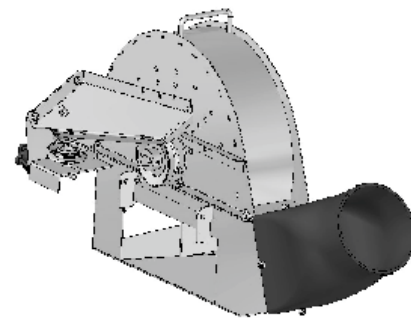

A0665 - WEIGHT KIT



(1) B0529 LEFT &
(1) B0528 RIGHT
LOWER MAIN
FRAME LEGS



(1)
C0061
EXHAUST
DEFLECTOR

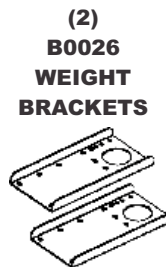

(2)
B0026
WEIGHT
BRACKETS



(1)
HB0370
HARDWARE
BAG

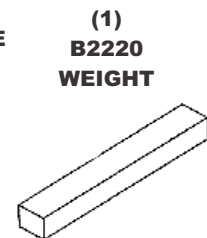

(1)
B2220
WEIGHT

MODEL#: 35031504

MOWER NAME: EXMARK

MOWER MODEL: NEW GENERATION LAZER Z

MOWER DECK SIZE: 52"

VAC NAME: 15 CUBIC FOOT PRO BAGGER

DECK DRIVE

MANUAL: #Q0400

A1754 UNIT ASSEMBLY



FOR YEAR: 2010

REVISED:

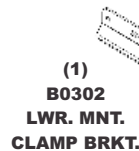
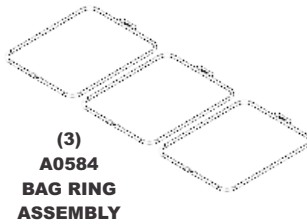
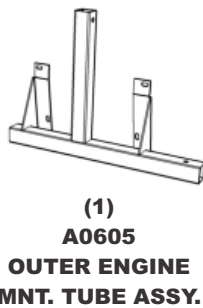
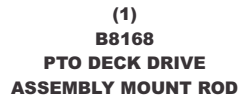
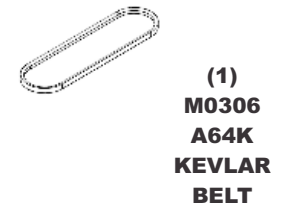
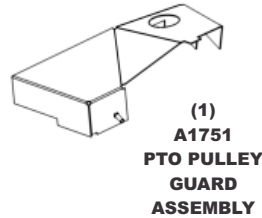
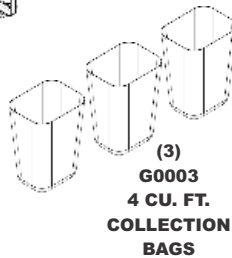
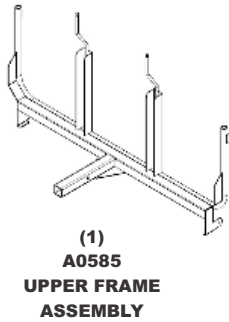
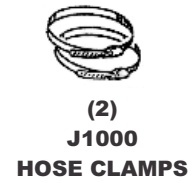
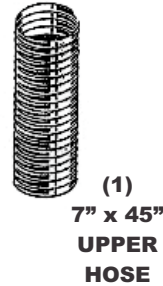
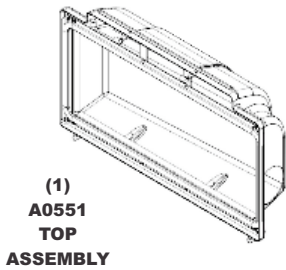

A1055 - PTO DECK DRIVE ASSEMBLY

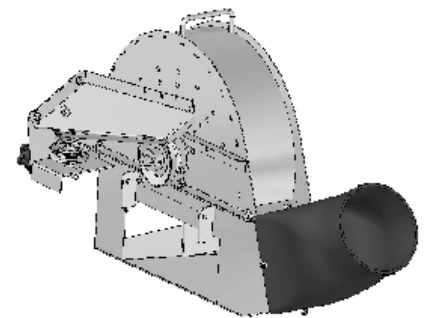

A0665 - WEIGHT KIT

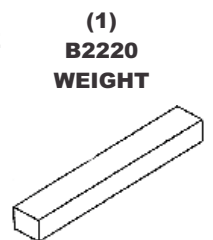
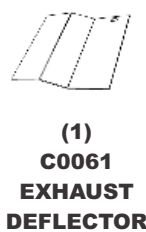

SECTION III

OPERATING INSTRUCTIONS

3-1 General Safety

Only qualified people familiar with this operator's manual and the mower's operator's manual should operate this machine.

3-2 Operation & Tips On Mowing

- A. Perform BEFORE EACH USE maintenance list in paragraph 4-1.
- B. Start mower.
- C. With the mower at high idle speed, engage the mower deck.
- D. Proceed to operate the control levers of the mower.

NOTE: If the collection system does not appear to be collecting the grass clippings; disengage the deck, and blower, engage the parking brake and turn the mower off. Check the upper hose, lower hose, top screen and boot for clogs.

To obtain the maximum effectiveness from your collection system the tips listed below should be followed:

- * Watch your speed- Normal conditions will allow a speed of up to approximately 5 mph, but thick, heavy damp conditions will require reduced ground speed.
- * Mow with sharp blades- A sharp blade cuts cleaner.
- * Wet grass and leaves will decrease effectiveness and will increase horsepower requirements.
- * Mow at higher cutting heights- Remove and mulch no more than 2" of grass length with each mowing. (Experts recommend not cutting off more than 1/3 of the grass blade length at any given time.)
- * Mow twice, at different height settings, (high, then low), if grass is extra tall.
- * Remember that horsepower requirements will vary with the mowing conditions such as type and height of turf grass, moisture content, amount of leaves, whether the terrain is flat or sloped, etc.

3-3 Unloading The Collection System

- A. Stop the forward movement of the mower.
- B. Disengage the mower deck.
- C. Using the throttle cable slow the engine down to idle.
- D. Engage the parking brake.

E. Once the parking brake has been engaged, then and only then, walk behind the mower and check the collection bags by lifting the plastic hood. Load in bags should not exceed the height of the installed bag.

F. To release bags from frame, lift bag ring from tab on bagger frame, slide bag out and turn bags over to deposit clippings.

G. Follow steps on page 14 to re-attach bags back to the bagger.

NOTE: Do not allow collection bags to become over-filled as potential damage may occur to your equipment. Also, be sure to clean the hood screen as needed.

SECTION IV MAINTENANCE

4-1 Maintenance Checklist

Before each use:

1. Check blades and spindles to be sure that no foreign objects, such as wire or steel strapping bands, are wrapped around them.
2. Inspect blades for wear. Replace if necessary. If it is necessary to sharpen the blades, remove the blades from the spindles before sharpening. **DO NOT** sharpen blades while still attached to the mower.
3. Make sure all shields are in place and in good condition. Repair or replace any missing or damaged shields.
4. Listen for abnormal sounds, which might indicate loose parts, damaged bearings, or other damage. Correct any deficiency before continuing operation.
5. Check for wear or deterioration of the upper or lower hoses. If there are any portions of the hose that have been torn or worn through, replace with genuine PECO parts.

After Each Use:

1. Clean all debris from machine especially from the container, and off of safety decals. Replace any missing or illegible decals.
2. Clean all debris from the box screen.
3. Inspect unit for worn or damaged components. Repair or replace before the next use. Any replacement component installed during repair shall include the components current safety decal specified by the manufacturers to be affixed to the component.

SECTION V PARTS AND SERVICE

5-1 Parts And Service Information

PeCo collection system owners should record the name and telephone number of their Service Center. Your Service Center will be happy to supply replacement parts, accessories, and do any service or repairs to your collection system. If for any reason your Service Center is unable to service your collection system or supply replacement parts, contact PeCo and include the following information on the chart below.

THE SERIAL NUMBER PLATE IS
LOCATED ON THE PTO
DECK DRIVE ASSEMBLY
P#(A1055)

PECO	
OUTDOOR POWER EQUIPMENT	
Model Number	<input style="width: 95%;" type="text"/>
Serial Number	<input style="width: 95%;" type="text"/>
Arden, North Carolina 28704	

WRITE THE MODEL AND
SERIAL NUMBER IN THE
BOX ABOVE FOR FUTURE
REFERENCE.

THE SERIAL NUMBER PLATE
IS LOCATED ON THE BAG
ASSEMBLY TOP P#(A0794)

PECO	
OUTDOOR POWER EQUIPMENT	
Model Number	<input style="width: 95%;" type="text"/>
Serial Number	<input style="width: 95%;" type="text"/>
Arden, North Carolina 28704	

WRITE THE MODEL AND
SERIAL NUMBER IN THE
BOX ABOVE FOR FUTURE
REFERENCE.

Unit Model Number: _____

Unit Engine Size: _____

Unit Serial Number: _____

Date of purchase: ____/____/____

Dealer/Distributor Name: _____

Dealer's/Distributor's: _____ **State:** _____ **Zip:** _____

Phone Number: _____

Address: PECO Inc.
100 AIRPORT ROAD
Arden, NC 28704
Phone #: (828) 684-1234 or Toll Free: (800) 438-5823
Email: peco@lawnvac.com

SAFETY DECALS

To promote safe operation, PECO supplies safety decals on all products manufactured. Damage can occur to safety decals either through shipment, use or reconditioning. Contact your local Service Center for replacement decals.



Part #: R1090



Part #: R2007

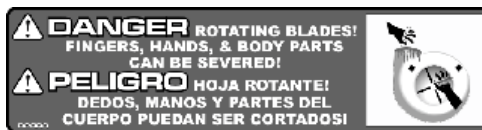

Part #: R2008



Part #: R1069



Part #: R1057



Part #: R1053



Part #: R1054



Part #: R4015



Part #: R1065



Part #: R4008



Part #: R1051



Part #: R1070

TORQUE SPECIFICATIONS

Proper torque for American fasteners used on Peco equipment.
Recommended Torque in Foot Pounds (Newton Meters).*

AMERICAN Bolt Head Markings

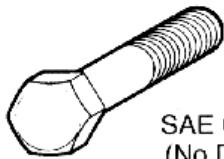

SAE Grade 2
(No Dashes)

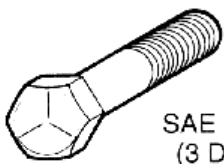

SAE Grade 5
(3 Dashes)

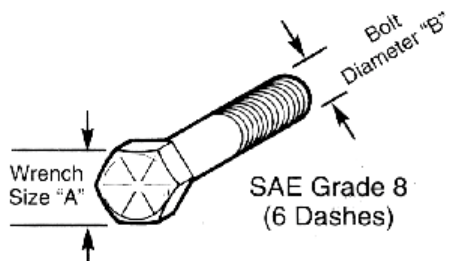

SAE Grade 8
(6 Dashes)

WRENCH SIZE (IN.) "A"	BOLT DIAMETER (IN.) "B" AND THREAD SIZE	SAE GRADE 2	SAE GRADE 5	SAE GRADE 8
7/16	1/4 - 20 UNC	6 (7)	8 (11)	12 (16)
7/16	1/4 - 28 UNF	6 (8)	10 (13)	14 (18)
1/2	5/16 - 18 UNC	11 (15)	17 (23)	25 (33)
1/2	5/16 - 24 UNF	13 (17)	19 (26)	27 (37)
9/16	3/8 - 16 UNC	20 (27)	31 (42)	44 (60)
9/16	3/8 - 24 UNF	23 (31)	35 (47)	49 (66)
5/8	7/16 - 14 UNC	32 (43)	49 (66)	70 (95)
5/8	7/16 - 20 UNF	36 (49)	55 (75)	78 (106)
3/4	1/2 - 13 UNC	49 (66)	76 (103)	106 (144)
3/4	1/2 - 20 UNF	55 (75)	85 (115)	120 (163)
7/8	9/16 - 12 UNC	70 (95)	109 (148)	153 (207)
7/8	9/16 - 18 UNF	79 (107)	122 (165)	172 (233)
15/16	5/8 - 11 UNC	97 (131)	150 (203)	212 (287)
15/16	5/8 - 18 UNF	110 (149)	170 (230)	240 (325)
1-1/8	3/4 - 10 UNC	144 (195)	266 (360)	376 (509)
1-1/8	3/4 - 16 UNF	192 (260)	297 (402)	420 (569)
1-5/16	7/8 - 9 UNC	166 (225)	430 (583)	606 (821)
1-5/16	7/8 - 14 UNF	184 (249)	474 (642)	668 (905)
1-1/2	1 - 8 UNC	250 (339)	644 (873)	909 (1232)
1-1/2	1 - 12 UNF	274 (371)	705 (955)	995 (1348)
1-1/2	1 - 14 UNF	280 (379)	721 (977)	1019 (1381)
1-11/16	1-1/8 - 7 UNC	354 (480)	795 (1077)	1288(1745)
1-11/16	1-1/8 - 12 UNF	397 (538)	890 (1206)	1444 (1957)
1-7/8	1-1/4 - 7 UNC	500 (678)	1120 (1518)	1817 (2462)
1-7/8	1-1/4 - 12 UNF	553 (749)	1241 (1682)	2013 (2728)
2-1/16	1-3/8 - 6 UNC	655 (887)	1470 (1992)	2382 (3228)
2-1/16	1-3/8 - 12 UNF	746 (1011)	1672 (2266)	2712 (3675)
2-1/4	1-1/2 - 6 UNC	870 (1179)	1950 (2642)	3161 (4283)
2-1/4	1-1/2 - 12 UNF	979 (1327)	2194 (2973)	3557 (4820)

METRIC

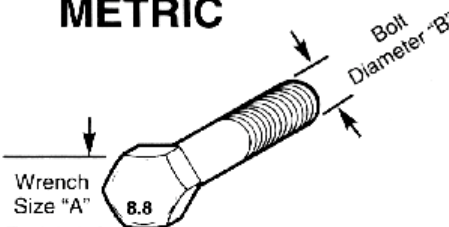

Numbers appearing on bolt heads indicate ASTM class.

Proper torque for metric fasteners used on Peco equipment.
Recommended torque in foot pounds (newton Meters).*

WRENCH SIZE (mm) "A"	BOLT DIA. (mm) "B"	ASTM 4.6	ASTM 8.8	ASTM 9.8	ASTM 10.9
8	5	1.8 (2.4)		5.1 (6.9)	6.5 (8.8)
10	6	3 (4)		8.7 (12)	11.1 (15)
13	8	7.3 (10)		21.1 (29)	27 (37)
16	10	14.5 (20)		42 (57)	53 (72)
18	12	25 (34)	74 (100)	73 (99)	93 (126)
21	14	40 (54)	118 (160)	116 (157)	148 (201)
24	16	62 (84)	167 (226)	181 (245)	230 (312)
30	20	122 (165)	325 (440)		449 (608)
33	22		443 (600)		611 (828)
36	24	211 (286)	563 (763)		778 (1054)
41	27		821 (1112)		1138 (1542)
46	30	418 (566)	1119 (1516)		1547 (2096)

*Use 75% of the specified torque value for plated fasteners. Use 85% of the specified torque values for lubricated fasteners.

NOTES



**100 AIRPORT ROAD
ARDEN, NORTH CAROLINA 28704
(800) 438-5823 OR (828) 684-1234 FAX: (828) 684-0858
EMAIL: peco@lawnvac.com
WEBSITE: www.lawnvac.com**