



**Unit Model #: 5920**

**Mower:**

**Owner's Manual: Q0547**

**Mower Type:**

**Deck Size:**

**Vac Type: X20 Trailer Vac**

**Deck Type:**

**Drive Type: 6.5HP Briggs & Stratton Vanguard**

**Revision #: 1 - Updated on 08/30/2019 - XY**

**Fits Year(s): 2013 & Newer**

**Crate Contents**

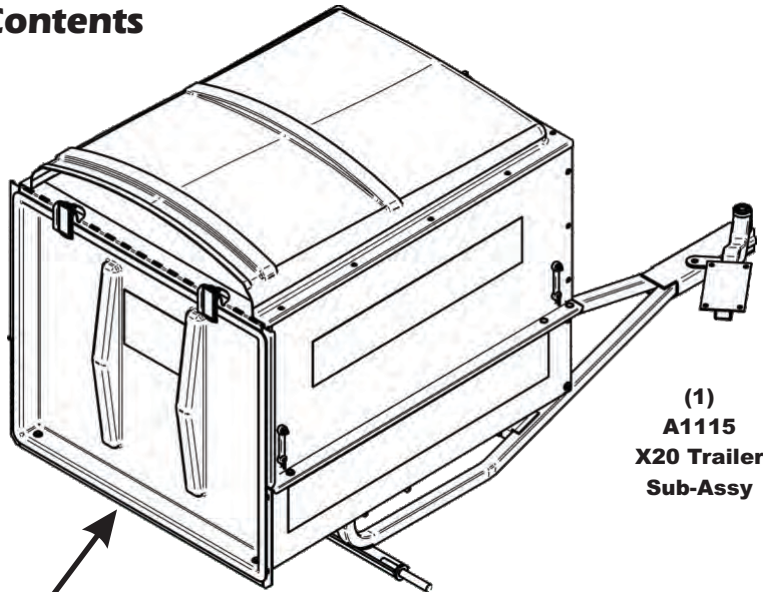

(1)  
A1115  
X20 Trailer  
Sub-Assy

**The contents below are placed inside of the X20 Trailer Sub-Assy**

(1)  
F0070-66  
7" x 66"  
Lower Hose

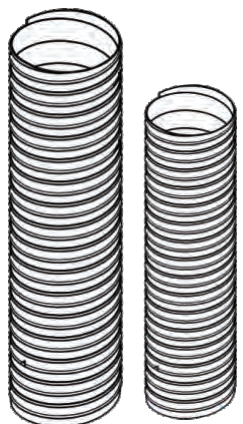

(1)  
F0060-60  
6" x 60"  
Upper Hose

(1)  
A0262  
Tail Gate  
Assy

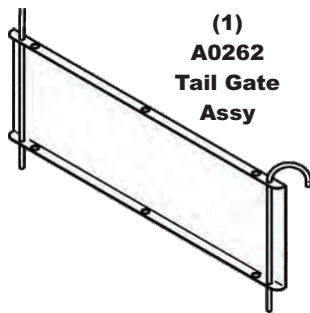

(2)  
H5001  
Wheel & Tire

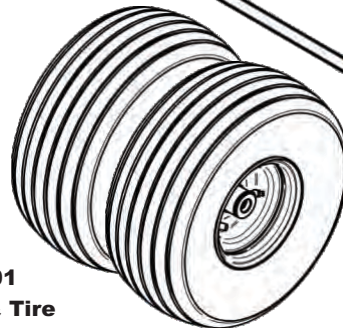

(1)  
Components  
Box

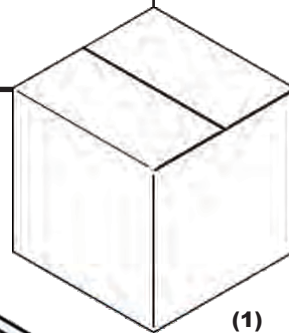

**Components Box Contents**

(2)  
J0060  
6" Hose  
Clamps



(1)  
E6004  
7" Blower  
Cone

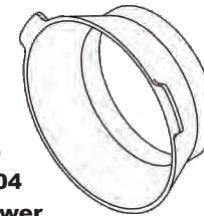

(2)  
J0070  
7" Hose  
Clamps



(1)  
A639  
B&S 6.5HP  
Assy w/ 4-Blade  
Impeller

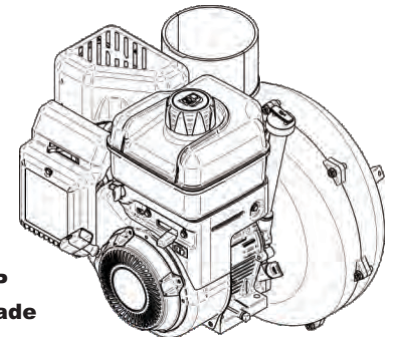

(1)  
HB0335  
X20 Trailer  
Hardware  
Bag



**A0121 Small Universal Boot Kit**

(1)  
A0849  
Boot Kit  
HW Bag



(1)  
V1018  
Universal  
Boot / Small

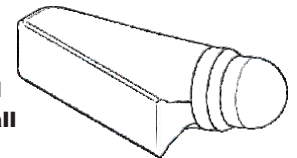

**A0137 Large Universal Boot Kit**

(1)  
A0856  
Boot Kit  
HW Bag



(1)  
V1049  
Universal  
Boot / Large

