



COLLECTION SYSTEM & UTILITY TRAILER

Model# 4920, 5920, 6930 & 7930

20 CUBIC FOOT **CONVERTIBLE** TRAILER VAC

Briggs & Stratton 9XX Series **4920**

6.5 HP Briggs & Stratton Vanguard **5920**

30 CUBIC FOOT **CONVERTIBLE** TRAILER VAC

Briggs & Stratton 9XX Series **6930**

6.5 HP Briggs & Stratton Vanguard **7930**



OPERATOR'S MANUAL

ASSEMBLY • OPERATION • MAINTENANCE

GRASS COLLECTION SYSTEM

TABLE OF CONTENTS

SECTION	PAGE	SECTION	PAGE
Safety	2	Engine Stay Assembly Installation	13
Safety Alert Symbols	3	Engine Stay Adjustments	14-17
Warranty	4	Universal Boot Installation	18-20
I INTRODUCTION AND DESCRIPTION	5	Lower Hose Installation	20
Introduction	5	Impeller Blade Removal/Replacement	21
Description	5	Exploded Views & Parts List	22-37
II INSTALLATION FOR USE	6	Overall Parts List	38-41
Preparation of Parts	6-7	Safety Decals	42
Removing Trailer Pan	7	III OPERATING INSTRUCTIONS	43
Wooden Support Removal	7	General Safety	43
Removing Trailer from Pallet	8	Operation & Tips On Mowing	43
Attaching Trailer to Trailer Pan	8	Disengagement Of The PTO Assembly	43
Dump Handle Installation	8-9	Unloading The Collection System	43
Wheel Installation	9-10	IV MAINTENANCE	43
Trailer Top Installation	10	Maintenance Checklist	43
Engine/Blower/Blade Assembly Installation	11	Lubrication	43
Blower Cone Installation	11	V PARTS AND SERVICE	44
Inlet Ring Installation	11	Parts And Service Information	44
Upper Hose Installation	12	Torque Specifications	45
Attaching Trailer to Tractor	12	Troubleshooting	46

SAFETY

1. Read the operator's manual carefully and familiarize yourself with the proper use of your attachment. Do not allow anyone who is not acquainted with the Safety Instructions to use your attachment.
2. Know the controls and how to stop them quickly. **READ THE OPERATOR'S MANUAL!**
3. Do not allow children to operate the machine. Do not allow adults to operate it without proper instruction.
4. Be especially watchful of children and pets entering into the area while operating.
5. Keep your eyes and mind on your machine while mowing or operating your attachment. Don't let others distract you.
6. Do not attempt to operate your machine when not in the driver's seat.
7. Always shut off blades and engine when emptying the container.
8. Stop machine, shut off deck attachment, set parking brake, shut off engine and remove ignition key before removing clogs, removing or replacing hose, boot, blower cone, or performing any maintenance.
9. Mow across the face of slopes (not more than 10 degrees); never up and down the face.
10. It is recommended that the container be emptied when half full while operating on slopes. Start mowing on slopes when the container is empty.
11. Inspect your lawn and remove any foreign objects before mowing. Never deliberately run the mower across any foreign object.
12. Wear hearing protection.
13. Wear eye protection to prevent debris from getting into your eyes.

SAFETY

WARNING! NEVER operate the mower unless the discharge guard and either the deflector assembly or the vacuum collector adapter are fastened securely in place.

WARNING! Do not work around the mower deck boot or the blower area until you are certain that the mower blades and the blower impeller have stopped rotating.

WARNING! To avoid serious injury, perform maintenance on the vacuum collector; **ONLY AFTER STOPPING THE MOWER'S ENGINE AND WAITING FOR ALL MOVING PARTS TO COME TO A COMPLETE STOP.** Set the parking brake. Always remove the ignition key before beginning maintenance.

WARNING! For your own personal safety, **ALWAYS mow ACROSS the face of slopes and NEVER UP and DOWN the face. NEVER attempt to mow excessively steep slopes, and use caution when turning on any slope.**

Safety Alert Symbol



This Safety Alert Symbol means: **“ATTENTION! BECOME ALERT! YOUR SAFETY IS INVOLVED!”**

This symbol is used to call attention to safety precautions that should be followed by the operator to avoid accidents. When you see this symbol, carefully read the message that follows and heed its advice. Failure to comply with safety precautions could result in death or serious bodily injury.

Safety Signs

The signal words **DANGER**, **WARNING**, and **CAUTION** are used on the equipment safety signs. These words are intended to alert the viewer to the existence and the degree of hazard seriousness.



White letters on **RED**

This signal word indicates a potentially hazardous situation which, if not avoided, will result in death or serious injury.



Black letters on **ORANGE**

This signal word indicates a potentially hazardous situation which, if not avoided, could result in death or serious injury.

It may also be used to alert against unsafe practices.



Black letters on **YELLOW**

This signal word indicates a potentially hazardous situation which, if not avoided, will result in minor or moderate injury.

It may also be used to alert against unsafe practices.

PECO LIMITED WARRANTY FOR NEW PRODUCTS

New PECO, Inc. extends the following warranties to the ORIGINAL PURCHASER of each New PECO, Inc. consumer product purchased from one of our Dealers or directly from New PECO, Inc., subject to the following limitations:

A. ITEMS COVERED UNDER WARRANTY

1. **PRODUCT WARRANTY** – Any part or parts which are deemed defective in material or workmanship, as delivered to the original purchaser, will either be repaired or replaced, as New PECO, Inc. elects, without charge for parts or labor, if the defect appears within 12 months from the date of purchase of the product to the Original Purchaser.
2. **PARTS REPLACED DURING WARRANTY** – Any New PECO, Inc. part which is furnished in performance of this warranty and is defective in material or workmanship as delivered to the purchaser will be repaired or replaced, as New PECO, Inc. elects, before the expiration of the original warranty period.

B. WARRANTY DISTINCTIONS

1. **RESIDENTIAL** - Products put to a personal use around a single household or residence are considered Residential. Products designated as “Residential” are warranted for 12 months from the date of purchase of the product, to the ORIGINAL PURCHASER with proof of purchase, when used for or in residential applications.
2. **COMMERCIAL** – Products put to any business use (agricultural, commercial or industrial) or used at multiple locations are considered Commercial. Products designated as “Commercial” are warranted for 12 months from the date of purchase of the product, to the ORIGINAL PURCHASER with proof of purchase, when used for or in commercial applications. Products designated as “Residential” are warranted for 90 days from the date of purchase of the product, to the ORIGINAL PURCHASER with proof of purchase, when used for or in Commercial applications.
3. **RENTAL** – Products used for Rental or Lease Purposes are warranted for 45 days from date of purchase of the product, to the ORIGINAL PURCHASER with proof of purchase, when used for or in a rental business.

C. ITEMS NOT COVERED BY NEW PECO WARRANTY

1. **ENGINES & BATTERIES:** Engines and Batteries attached to New PECO, Inc. products are covered under their respective separate manufacturer warranties and those companies must be contacted directly to file a warranty claim. Briggs & Stratton: https://www.briggsandstratton.com/na/en_us/support/warranty.html
2. **UNAPPROVED ALTERATION OR MODIFICATION:** All obligations of New PECO, Inc. under this warranty shall be terminated if products are altered or modified in any way not approved by New PECO, Inc.
3. **ACCIDENTS & NORMAL MAINTENANCE:** This warranty covers ONLY manufacturers defective material and workmanship. It does not cover depreciation or damage caused by normal wear & tear, accident, improper maintenance, misuse or abuse of products. New PECO, Inc. products must be operated and maintained in accordance with the instructions furnished in the manuals. The cost of normal maintenance and normal replacement of service items such as belts, cutting blades, hoses, bags, etc., which are not defective shall be paid for by the purchaser.
4. **NO SERVICE CENTER WARRANTY:** The selling Service Center/Dealer makes no warranty on his own on any item warranted by New PECO, Inc. unless he delivers to purchaser a separate written warranty certificate specifically warranting the item. The Service Center or Dealer has no authority to make any representation or promise on behalf of New PECO, Inc. or to modify the terms of the original warranty in any way.
5. **NO REPRESENTATIONS ADDITIONAL WARRANTIES, DISCLAIMER:** Neither New PECO, Inc. nor any company affiliated with New PECO, Inc. makes any warranties, representations or promises as to the quality of performance of its products other than those set forth herein. Except as described above, New PECO, Inc. makes no other warranties **AND SPECIFICALLY DISCLAIMS ANY AND ALL IMPLIED WARRANTIES OF FITNESS AND MERCHANTABILITY.**
6. **REMEDIED EXCLUSIVE:** The only remedies the purchaser has in connection with the breach or performance of any warranty on New PECO, Inc. consumer products are set forth above. In no event will New PECO, Inc. be liable for special incidental or consequential damages.

Warranty service is available through your local authorized service dealer or distributor. If you do not know the dealer or distributor in your area, search by your zip code on www.lawnvac.com or contact our Sales Department at New PECO, Inc. 800-438-5823 or email Sales@lawnvac.com.

Section I - INTRODUCTION AND DESCRIPTION

Introduction

We are pleased to have you as a PECO customer. Your collection system has been designed to give you a low maintenance, simple, and effective way to collect the grass clippings from your mower. This manual is provided to give you the necessary instructions to properly mount, operate and maintain the collection system on your mower. Please read this manual thoroughly. Understand what each control is for and how to use it. Observe all safety decal precautions on the machine and noted throughout the manual.

NOTE: All references made to right, left, front, rear, top or bottom are as viewed from the normal operator's position on the mower.

Description

The grass collection system is designed for turf maintenance where there is a need to collect the grass clippings as the mower cuts the turf. It is also used for picking up leaves in pre-season and post-season clean-up. The engine/blower/blade assembly, is mounted on the right side of the unit. The blower draws grass clippings from the discharge area up and back to the container mounted to the rear of the mower. The operator can engage the engine/blower/blade assembly by starting the engine. Once the container is full of clippings, the operator can remove the rear door and then easily pull and lift the handle to dump.



Section II - INSTALLATION FOR USE

Preparation Of Parts

PECO Trailer Vacs are shipped as shown in Figure A.

Note: The following instructions are used in the installation of both the X20 Trailer Vac & X30 Trailer Vac.

Figure A



Shipping Crate

Remove the shrink wrap as shown in Figure B.

Figure B

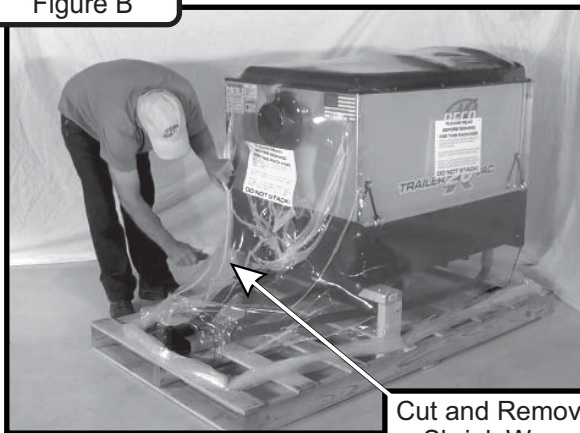

Cut and Remove Shrink Wrap

Remove the door as shown in Figure C. Rotate the red reflectors to release the door. Then lift up and out.

Figure C

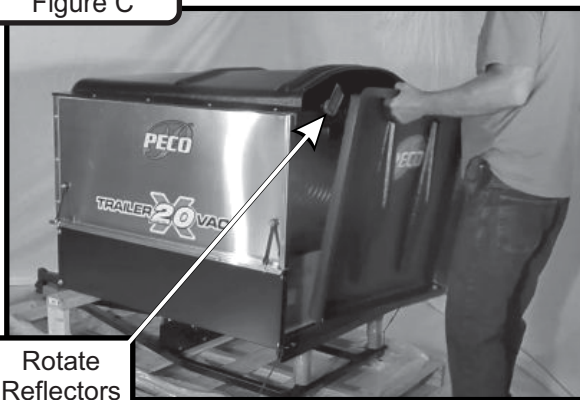

Rotate Reflectors

Remove the hoses as shown in Figure D.

Figure D



Release the (2) rubber straps (PER SIDE) as shown in Figure E.

Figure E

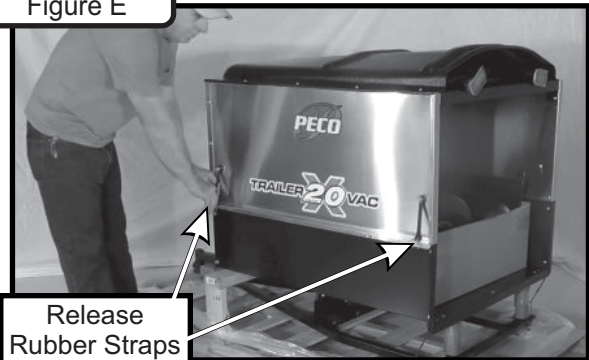

Release Rubber Straps

Remove the lightweight top as shown in Figure F.

Figure F



Remove all parts from trailer pan as shown in Figure G.

Figure G

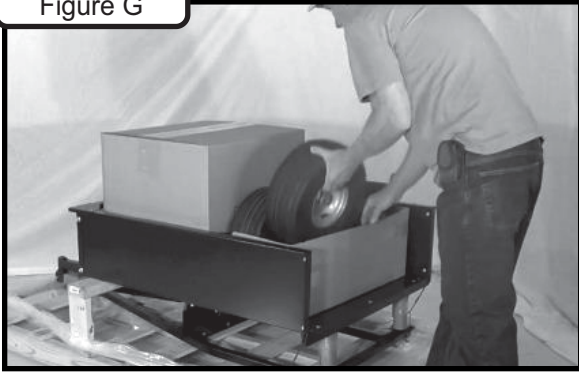

Lift the trailer pan off of the chassis and set the trailer pan upside down as shown in Figure D.

Figure D

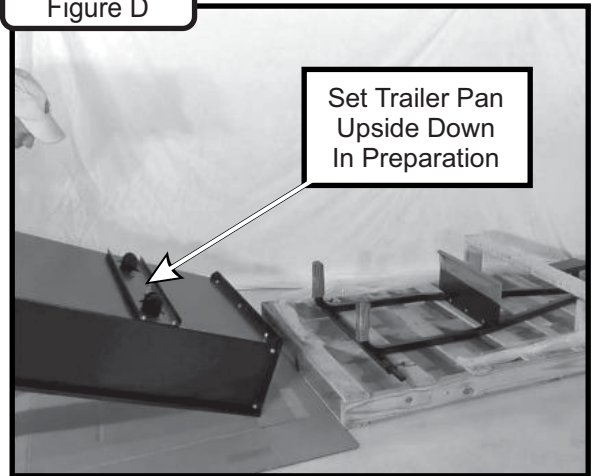

Removing Trailer Pan

Remove the (2) shipping screws from the front trailer pan as shown in Figure A.

Figure A

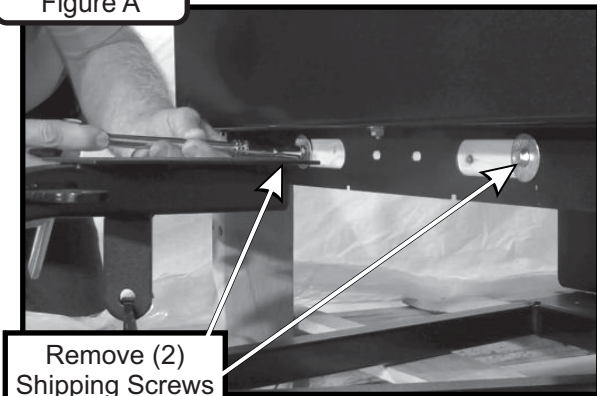

Wooden Support Removal

Using a hammer or pry bar, carefully remove the wooden supports from the shipping crate. The support consists of (3) pieces. (2) support legs and (1) top support. Refer to Figure A.

Figure A

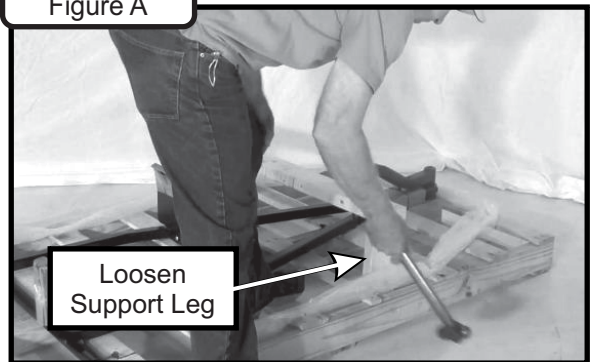

Cut and remove the (2) retaining wires from the trailer pan. Refer to Figure B.

Figure B

Cut (2) Retaining Wire

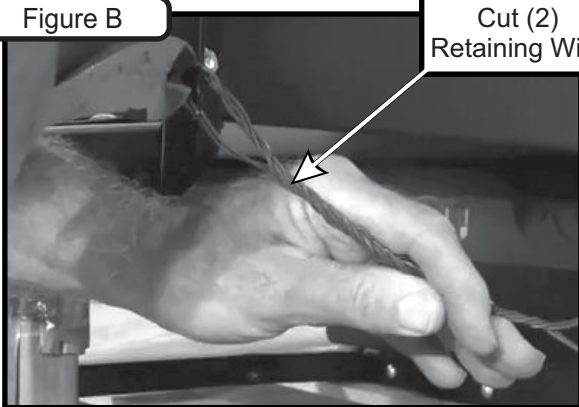

Using a hammer or pry bar, carefully loosen the top support and remaining support leg. Refer to Figure B.

Figure B

Loosen Support Top

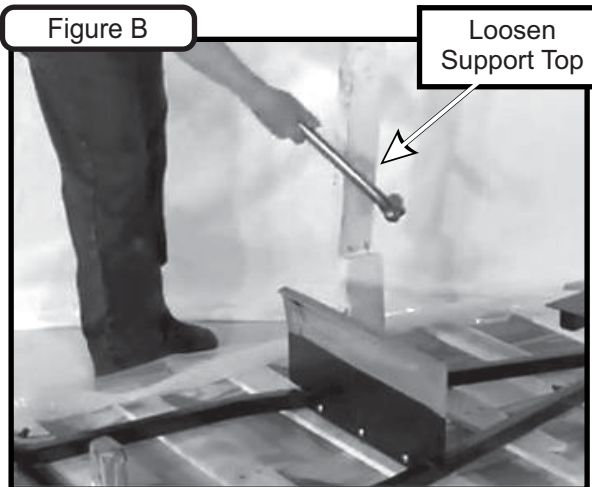

Removing Trailer From Pallet

Cut and remove the remaining retaining wires as shown in Figure A. Then lift and remove the trailer from the shipping crate as shown in Figure B.

Figure A

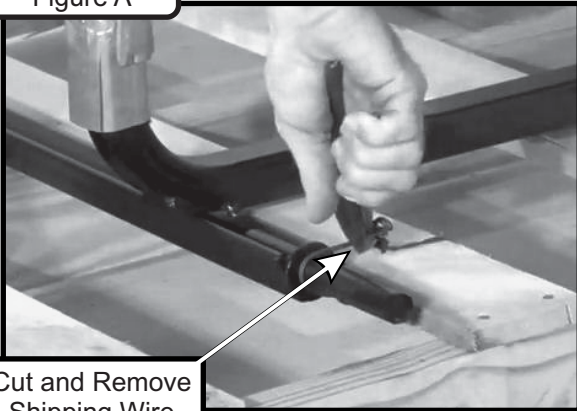

Cut and Remove Shipping Wire

Figure B

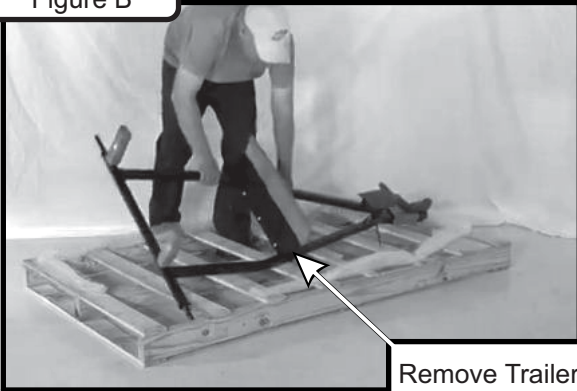

Remove Trailer

With the trailer upright on the ground, remove the cardboard from the trailer as shown in Figure C.
NOTE: Do not remove the engine mount arm zip tie.

Figure C

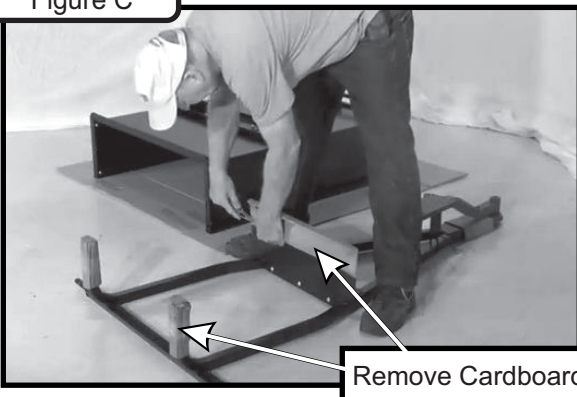

Remove Cardboard

Attaching Trailer to Trailer Pan

Flip the trailer over and place on the trailer pan as shown in Figure A.

Figure A

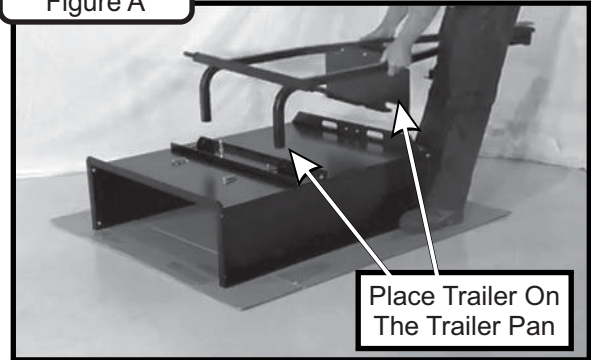

Place Trailer On The Trailer Pan

Attach the trailer to the trailer pan using (2) clevis pins P#(K0082) and (2) hair pin clip P#(K0086). Refer to Figure B.

Figure B

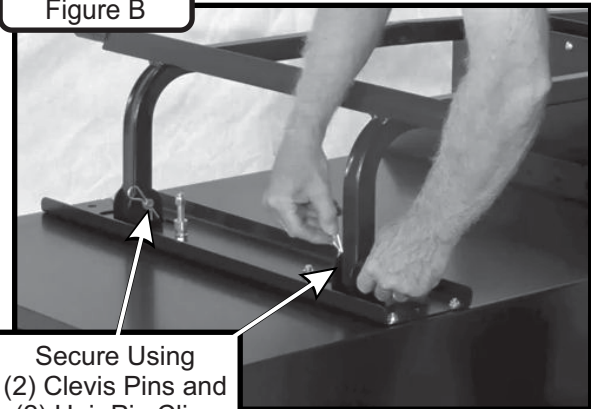

Secure Using (2) Clevis Pins and (2) Hair Pin Clips

Dump Handle Installation

Remove the existing 3/8" nut from the pivot bolt as shown in Figure A.

Figure A

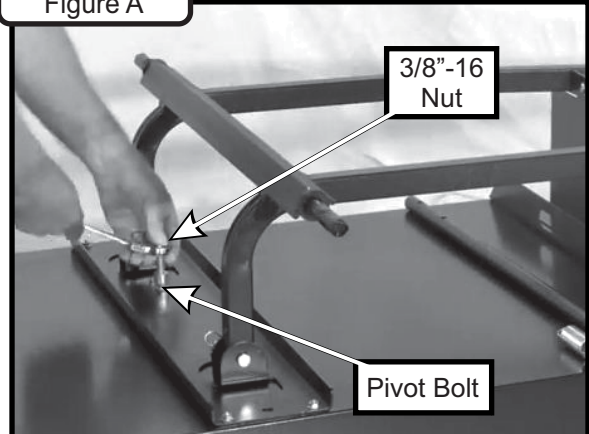

3/8"-16 Nut

Pivot Bolt

Insert the dump handle through the slot in the trailer pan and through the handle spring P#(J0310) as shown in Figure B.

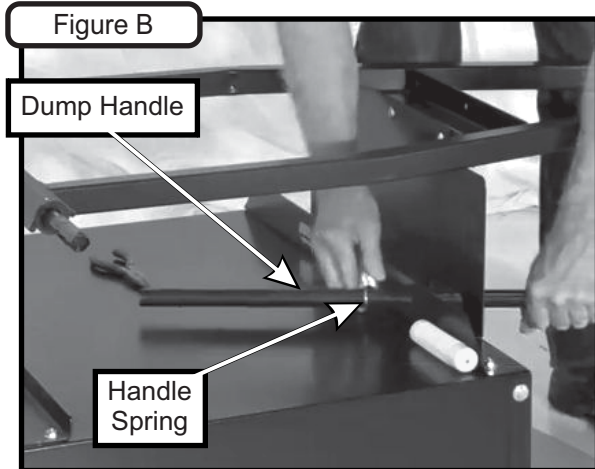

Note: The Dump Handle contains 2 holes that are specific to the type of Trailer Vac it is being installed on. The First hole is for the X30 Trailer Vac and the Second hole is for the X20 Trailer Vac.

Insert the pivot bolt through the hole corresponding with your Trailer Vac in the dump handle. Secure the handle to the pivot bolt using the 3/8"-16 Nut that was removed. Attach the hook end of the spring to the hole in the trailer pan. Refer to Figure C.

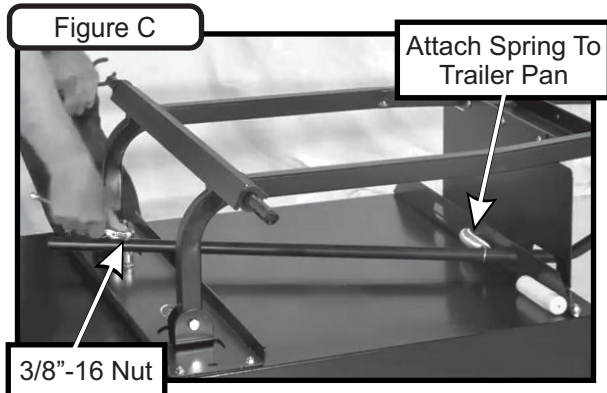

Insert the Handle Grip P#(J0522) onto the end of the dump handle as shown in Figure D.

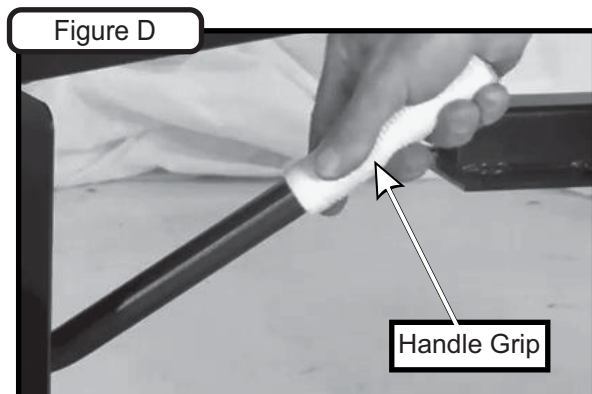

Wheel Installation

Remove the tape from both axles. Refer to Figure A and Figure B for reference.

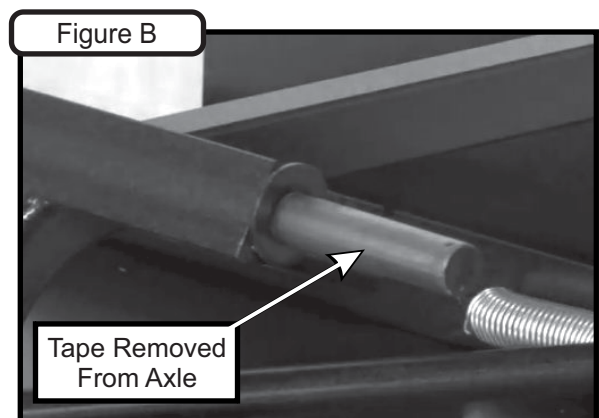
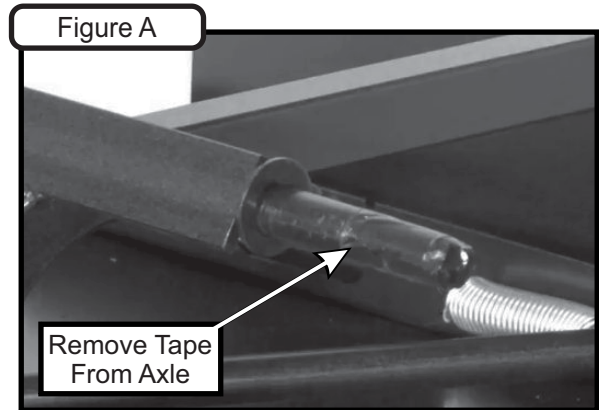

Insert the wheels onto the wheel axle as shown in Figure C. Secure each wheel using (1) 3/4" flat washer P#(K0061) and (1) 1/8"-1/2" cotter pin P#(K0085). Refer to Figure C and D.

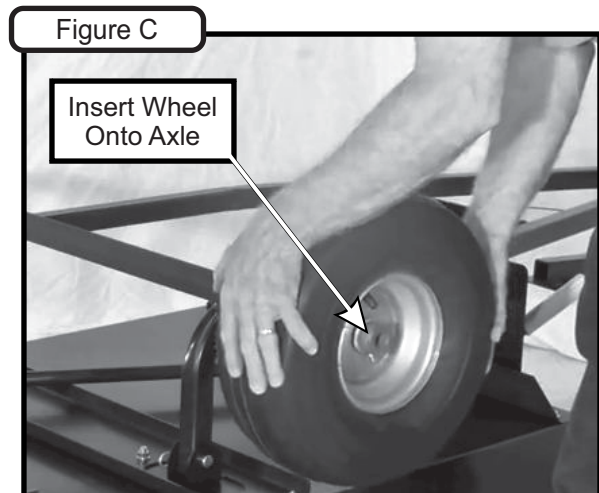
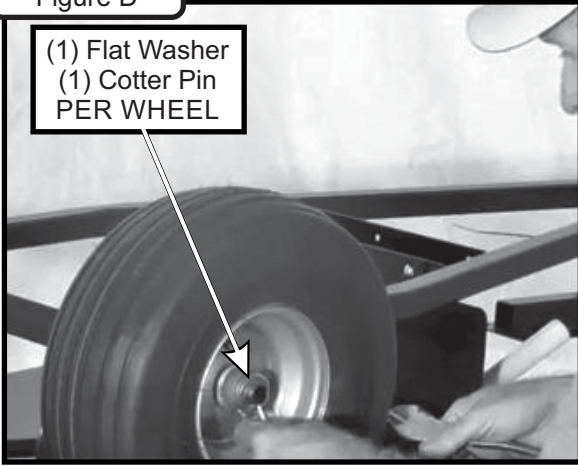

Figure D

(1) Flat Washer
(1) Cotter Pin
PER WHEEL



Flip the trailer over onto the wheels in preparation for the trailer top installation. Refer to Figure E.

NOTE: It is recommended that someone assist you during this step.

Figure E

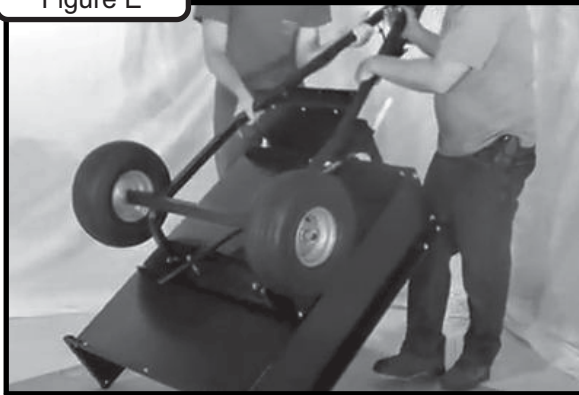

Trailer Top Installation

Lift the trailer top and place onto the trailer pan as shown in Figure A.

Figure A

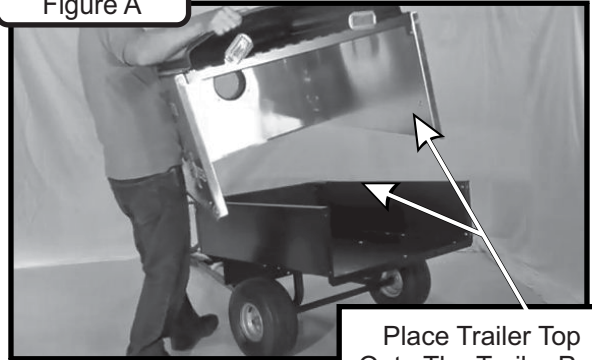

Place Trailer Top
Onto The Trailer Pan

Secure the trailer top to the trailer pan with the (4) rubber straps. Refer to Figure B.

Figure B

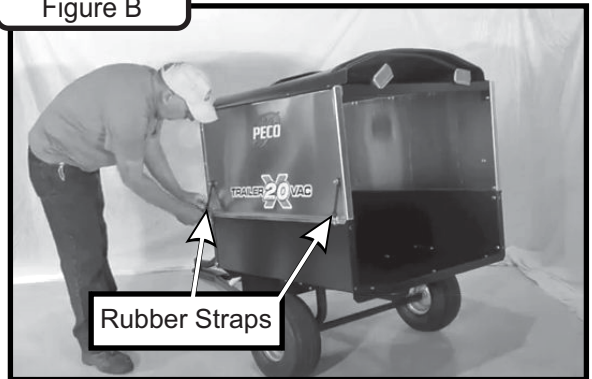

Rubber Straps

Attach the trailer door to the assembly. Secure the door by rotating the (2) red reflectors on the trailer top. Refer to Figure C.

Figure C

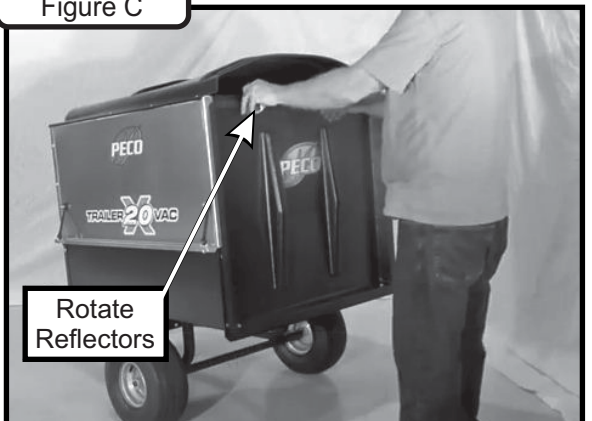

Rotate
Reflectors

Engine/Blower/Blade Assembly Installation

Remove the engine/blower/blade assembly from the box. Place the engine on top of the engine mount arm as shown in Figure A.

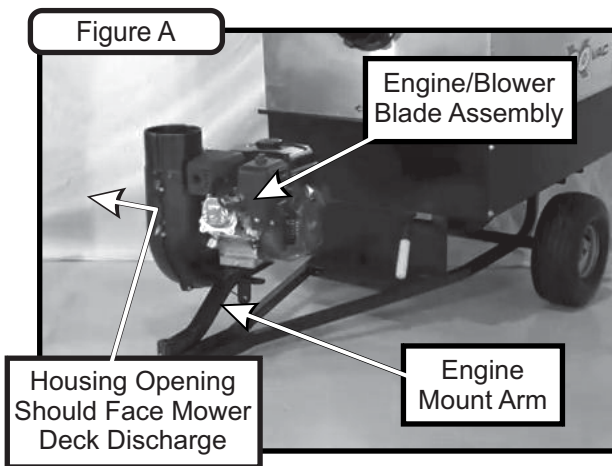

Secure the engine/blower/blade assembly to the engine mount arm with (4) 5/16"-18 x 1-1/2" hex bolts P#(K1157) and (4) 5/16"-18 locknuts P#(K2516). Refer to Figure B.

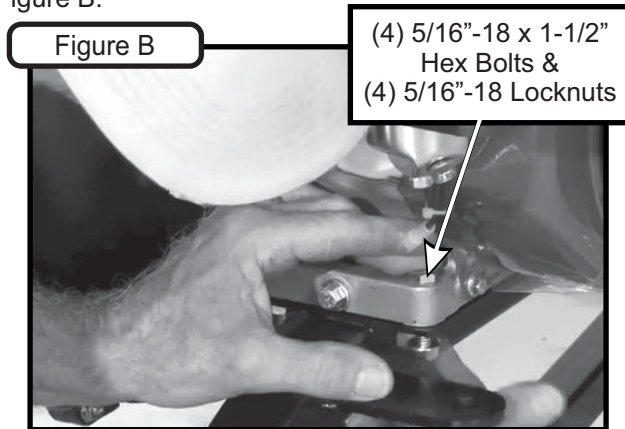

Blower Cone Installation

Loosen the blower cone hardware just enough so that you can remove the plastic cover from the blower housing shown in Figure A.

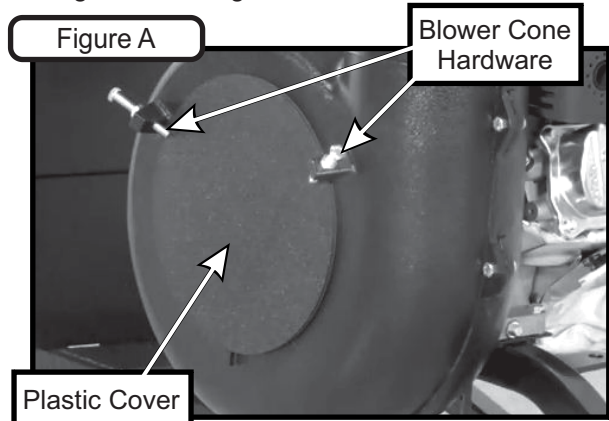

Insert the blower cone as shown in Figure B and secure with the existing blower cone hardware.

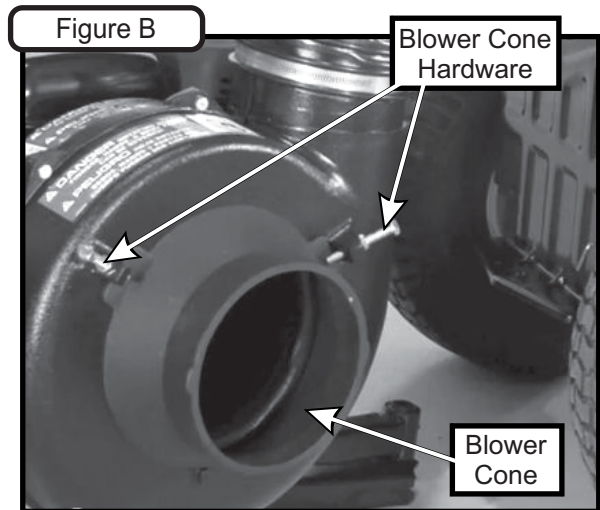

Inlet Ring Installation

Pull the Locking Pin P#(K0095) up from the Inlet Ring P#(V1052). Position the 6" Inlet P#(E8010) into the Inlet Ring and secure the 6" Inlet by pressing the Locking Pin back down. Refer to Figure A.

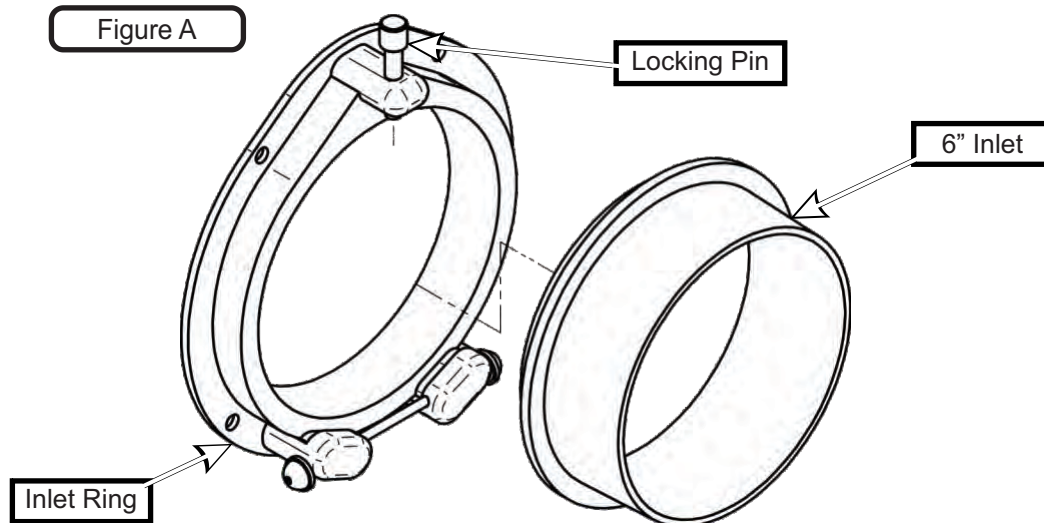

Upper Hose Installation

Before attaching the Upper Hose, place a Hose Clamp P#(J0060) relatively loose on both ends of the Upper Hose. Then insert one end of the 6" upper hose onto the blower outlet as shown in Figure A.

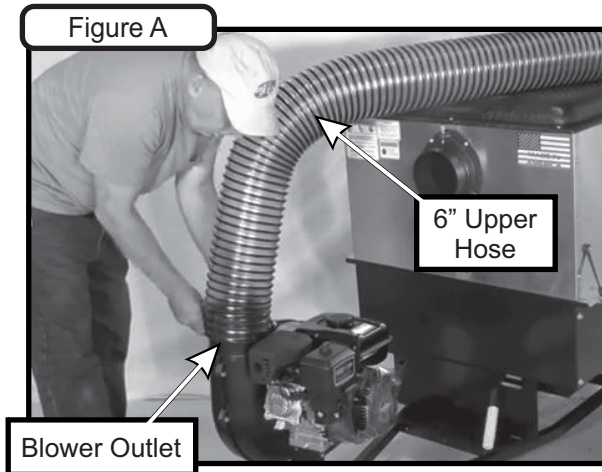

Attach the other end of the 6" upper hose to the inlet on the trailer top as shown in Figure B.

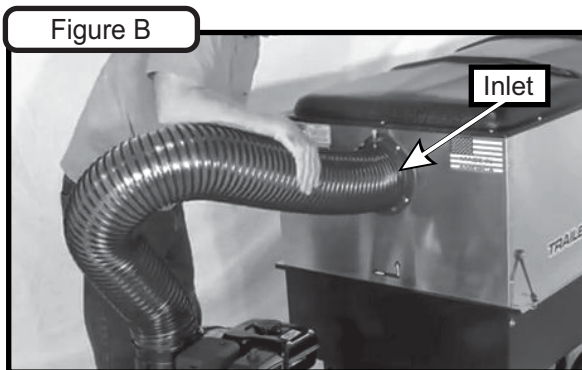

Secure the upper hose by tightening both hose clamps. Refer to Figure C.

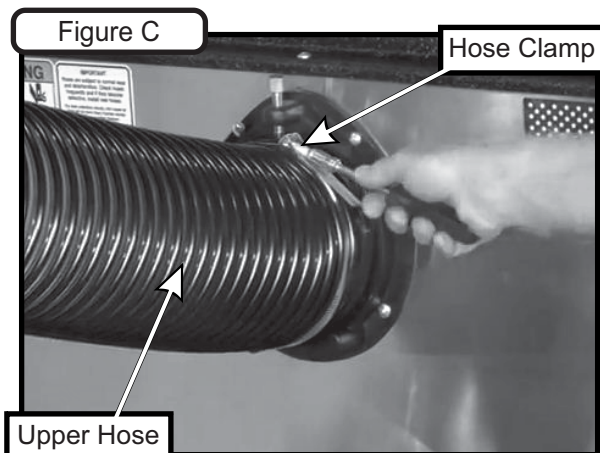

Attaching Trailer To Tractor

Back the tractor up to the trailer tongue. Lift the trailer tongue and slide onto the tractor hitch as shown in Figure A.

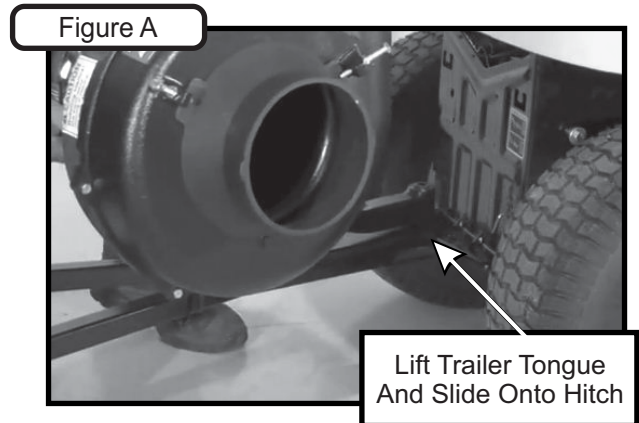

Secure the trailer tongue to the hitch with (1) hitch pin assembly P#(A0312). Refer to Figure B.

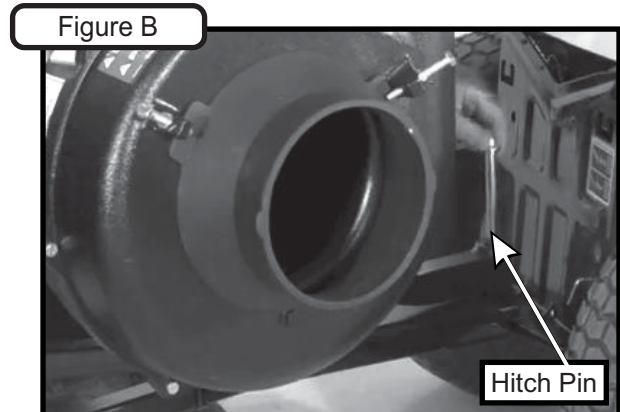

Secure the hitch pin using (1) hair pin clip P#(K0086). Refer to Figure C.

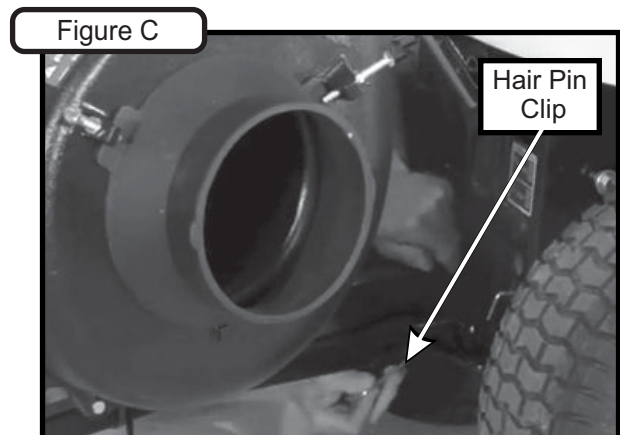

Engine Stay Assembly Installation

Note: Depending on the manufacturer and style of your tractor, the engine stay assembly mounting procedure may vary slightly from the instructions listed below.

Cut the zip tie that secures the engine mount arm to the trailer. Refer to Figure A.

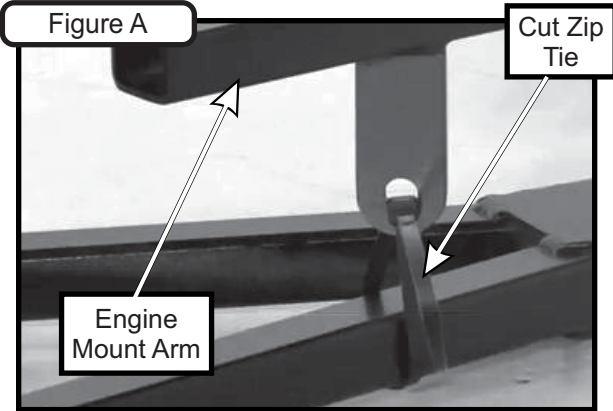

Rotate the engine towards the deck opening of the tractor as shown in Figure B. (See [Engine Stay Adjustments](#), pg. 14 through 17).

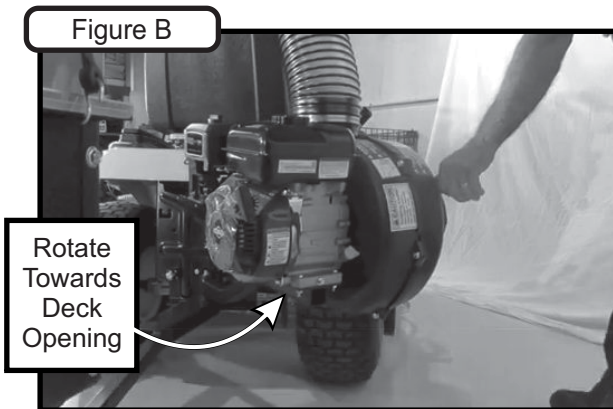

Attach the ball clevis P#(B0132) to the rear left of the tractor. There should be an existing hole in the tractor frame for this ball clevis to mount to. Secure the ball clevis using (1) 3/8"-16 x 1" hex bolt P#(K1191) and (1) 3/8" lock washer P#(K0048).

NOTE: If there is not an existing hole, position the ball clevis as shown in Figure C, then mark the position. Drill a hole in the tractor frame using a 3/8" drill bit.

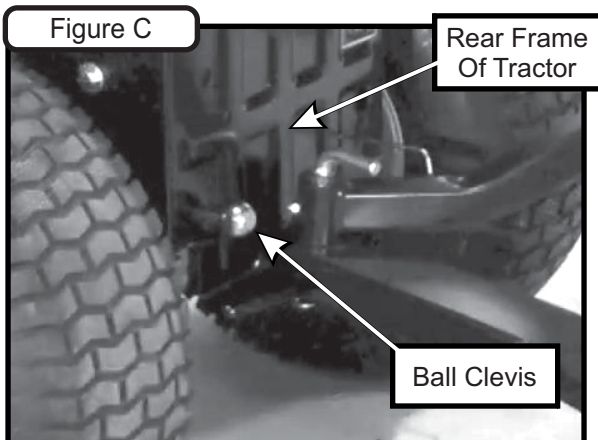

Attach the ball clevis clamp assembly P#(A0336) to the ball clevis using (1) 5/16"-18 x 2" hex bolt P#(K1159) and (1) 5/16"-18 locknut P#(K2516). Thread the adjusting rod P#(B4311) into the ball clevis clamp assembly as shown in Figure D. Insert the adjusting rod into the mounting hole on the engine mount arm. Secure the adjusting rod with (1) hair pin clip P#(K0099) and (1) 1/2" flat washer P#(K0055). Refer to Figure D and E for reference.

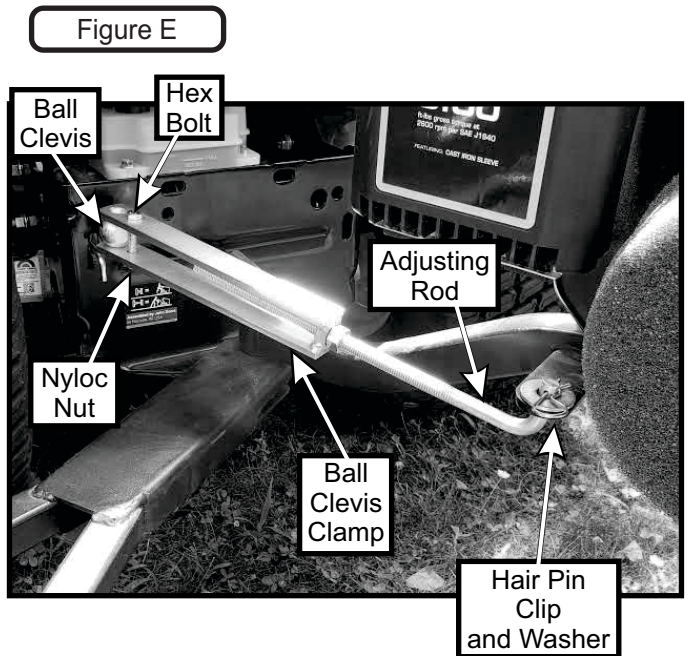
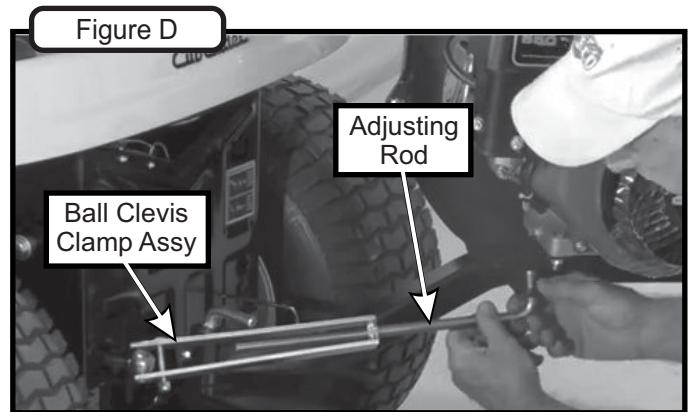

Engine Stay Adjustments

With your Engine Stay mounted it is recommended to position the Engine so that it sits between the rear tires and is angled about 35° to the right from the center of your tractor. This will keep the Engine stationary at the same position when the Trailer Vac swings left or right. Refer to Figure A, Figure B & Figure C for Engine position on a riding Lawn Tractor.

Figure A



Figure B



View of Collection Unit sitting to the Right of Operator

Figure C



View of Collection Unit sitting to the Left of Operator

Figure D - Figure F are views showing the Engine Positioning on a Zero Turn Mower.

Figure D



Figure E



View of Collection Unit sitting to the Right of Operator

Figure F



View of Collection Unit sitting to the Left of Operator

Universal Boot Installation

Remove the discharge chute from the mowing deck as shown in Figure A.

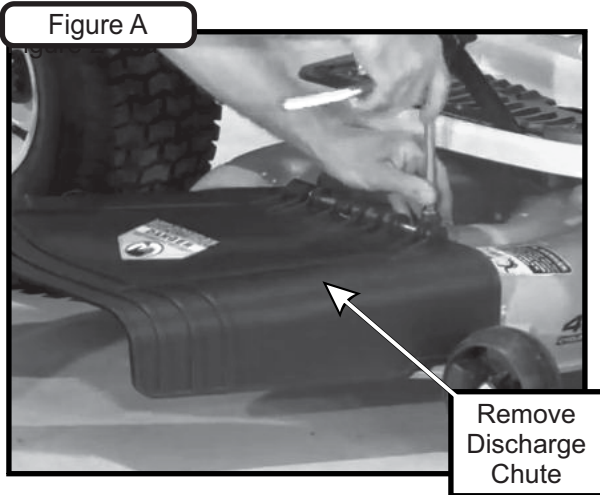

Position the plastic boot over the opening on the mower deck and trace the opening outline onto the plastic boot. Refer to Figure B.

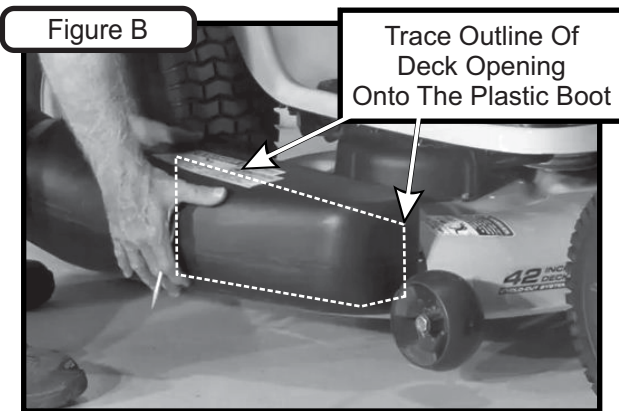

NOTE: To prevent injury, wear the appropriate personal protection equipment when drilling or cutting plastic boot.

Place plastic boot on a secure surface and carefully drill a hole into the plastic boot in preparation for the cutout. Use a 3/8" or 1/2" drill bit. Refer to Figure C for hole location.

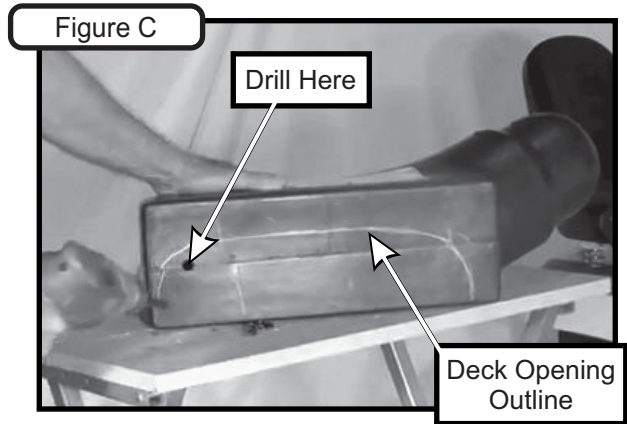

Using a jigsaw, cut along the traced outline and the bottom edge of the plastic boot. Discard the cutout portion of the boot. Refer to Figure D.

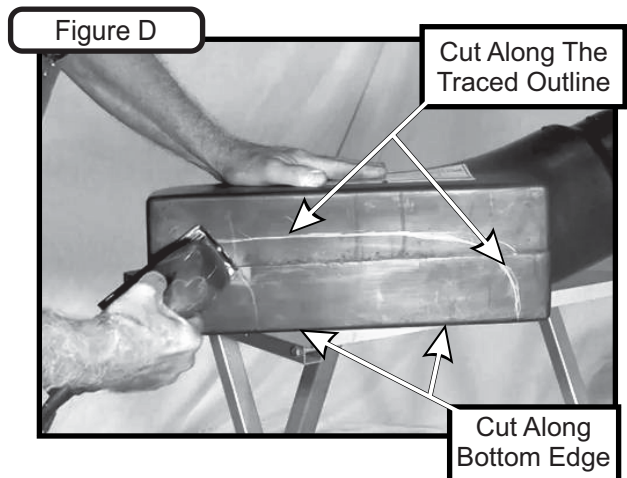

Place the plastic boot against the deck opening again and check for blade clearance. Trace the outline of the blade extent (with clearance) onto the bottom edge of the boot. Refer to Figure E.

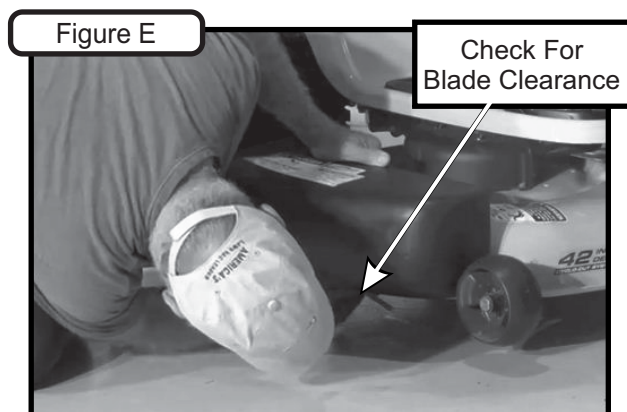

If necessary, cut out the traced underside of the plastic boot to allow for blade clearance. Refer to Figure F.

Figure F

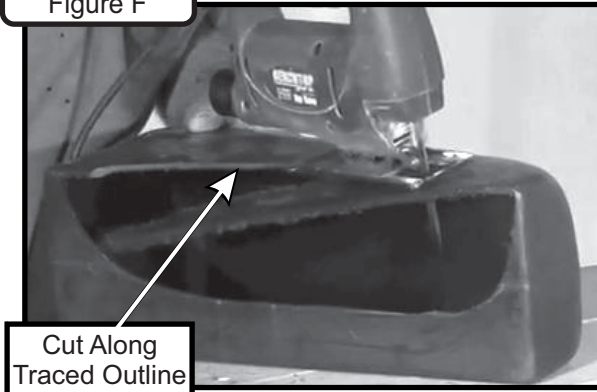

Position the boot over the deck opening and check for any gaps in the fit. Adjust the cut as needed. Make sure there are no gaps between the plastic boot and the mower deck. This will help prevent grass blowout.

Fasten the deck bracket P#(B2306) to the slide plate P#(B2307) using (2) 1/4"-20 x 5/8" carriage bolts P#(K1010) and (2) 1/4"-20 nylon flange locknuts P#(K2014). Refer to Figure G.

Figure G

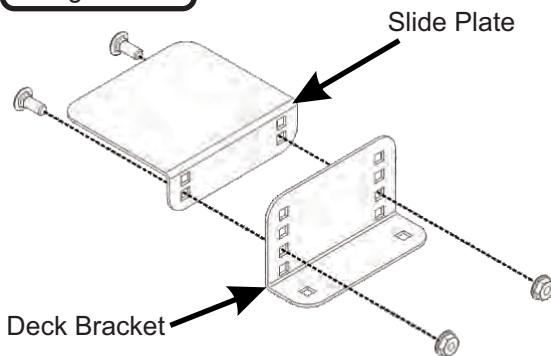

Place the plastic boot and deck bracket (with slide plate attached) firmly against the mower deck as shown in Figure H. Make sure there are no gaps between the plastic boot and the mower deck. Trace the (2) holes from the deck bracket onto the mower deck.

Figure H

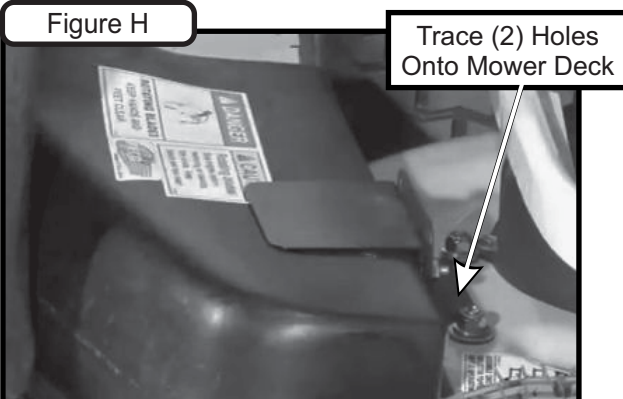

Center the upper clamp plate P#(B2308) over the slide plate and trace the (2) holes onto the plastic boot. Refer to Figure I.

Figure I

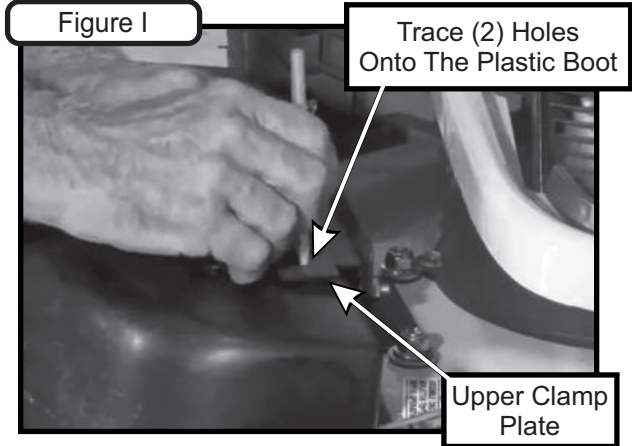

Drill the (2) holes traced onto the plastic boot with 1/4" drill bit as shown in Figure J.

Figure J

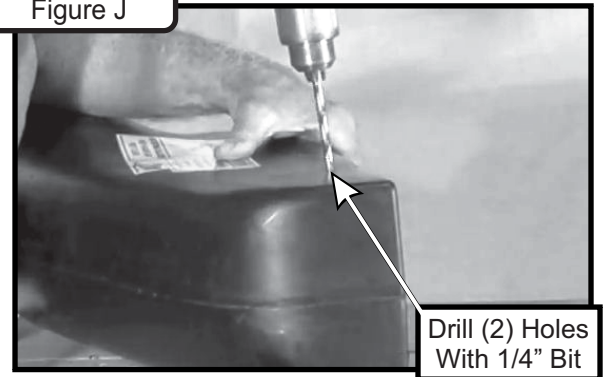

Drill the (2) traced holes in the mower deck using 1/4" drill bit as shown in Figure K.

Figure K

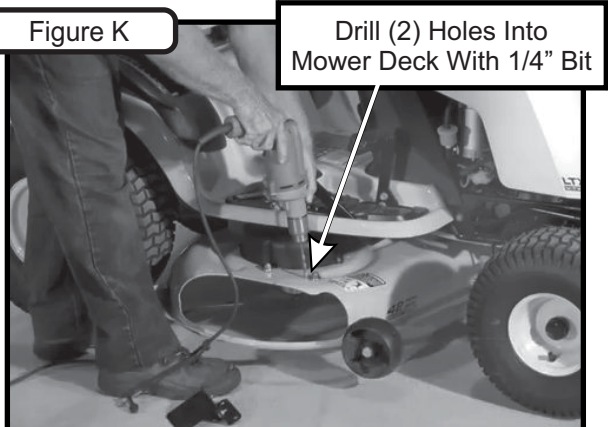

Insert (2) 1/4"-20 x 1" carriage bolts into the lower clamp plate P#(B2039). Insert the lower clamp plate through the cutout in the plastic boot. Push the carriage bolts in the lower clamp plate up through the holes drilled in the plastic boot. Refer to Figure L.

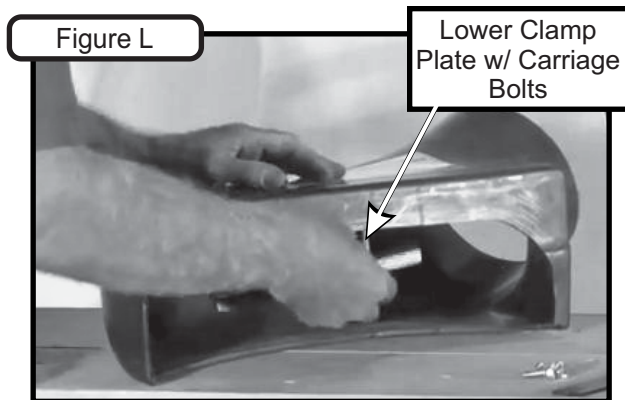

Insert the upper clamp plate P#(B2308) onto the (2) carriage bolts as shown in Figure M. Secure the upper clamp plate using (2) 1/4"-20 wing nuts P#(K1129).

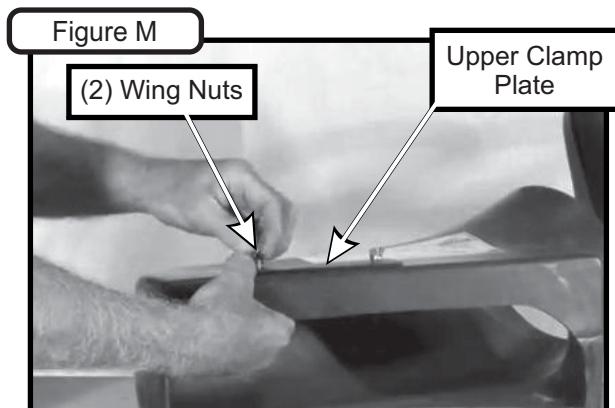

Slightly loosen the (2) wings nuts on the plastic boot. Insert the slide plate in between the upper clamp plate and the plastic boot. While pressing the boot firmly against the mower deck, tighten the (2) wing nuts as shown in Figure N.

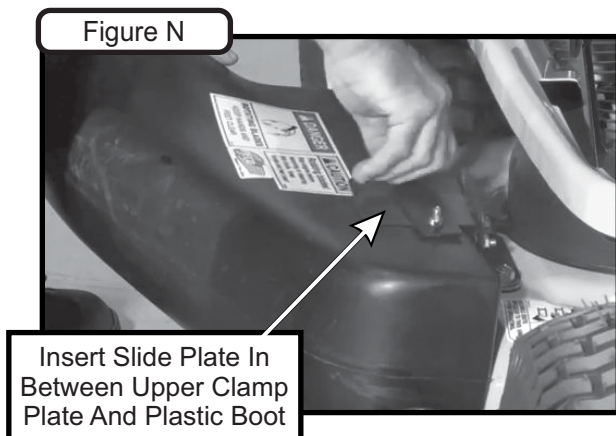

Lower Hose Installation

Attach one end of the 7" lower hose to the blower cone and the other end of the hose to the plastic boot. Secure the lower hose using (2) hose clamps P#(J1000). Refer to Figure A for reference.

Note: The lower hose must be cut to fit your machine. Do not cut the hose until you have tried to fit it on your machine. Remember that the hose has to be long enough to allow for enough clamping surface between the blower cone and the deck boot.

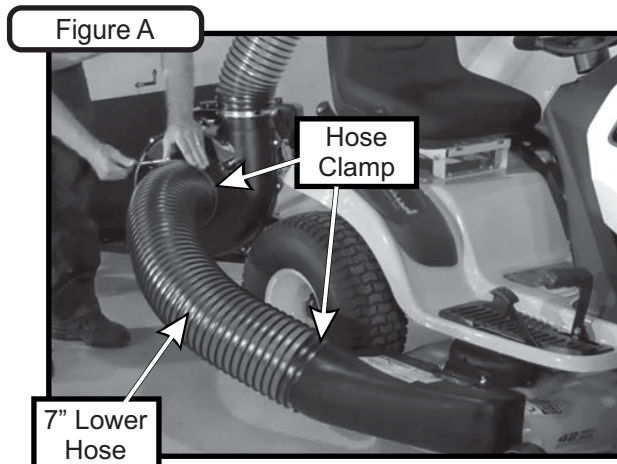

Impeller Blade Removal/Replacement

To Remove: First remove the 3/8"-24 x 1" GR8 HHCS P#(K0003) (#1), 3/8" Double Indented Washer P#(K0284) (#2) and (1) Tapered Washer P#(K0277) (#3) from the Taper-Lock Bushing P#(S4302) (#5). Next remove the (2) 1/4"-20 x 1" HHCS P#(K1225) (#4) and place them into the threaded holes of the Taper-Lock Bushing (#5). Gradually thread each bolt evenly into the Taper-Lock Bushing, forcing the blade to break-away from the Taper-Lock Bushing. If the Impeller will not move, carefully hit the base of the Impeller, between each vein, with a hammer, then try again.

To Replace: Firstly, start by applying anti-seize to the 3/8"-24 x 1" GR8 HHCS (#1) and set it aside. Then, place the Impeller Blade over the engine shaft. Slide the Taper-Lock Bushing (#5) on to the engine shaft and into the Impeller Blade, aligning the **non-threaded** holes of the Taper-Lock Bushing to the threaded holes of the Impeller Blade. Fasten by using (2) 1/4"-20 x 1" HHCS (#4), (1) Tapered Washer (#3), (1) 3/8" Double Indented Washer (#2), and (1) 3/8"-24 x 1" GR8 HHCS (#1). Torque to the proper specifications in the torque chart on the back of this manual. Next, rotate the Impeller Blade to ensure that the blade is clear of contact on all sides of the blower housing.

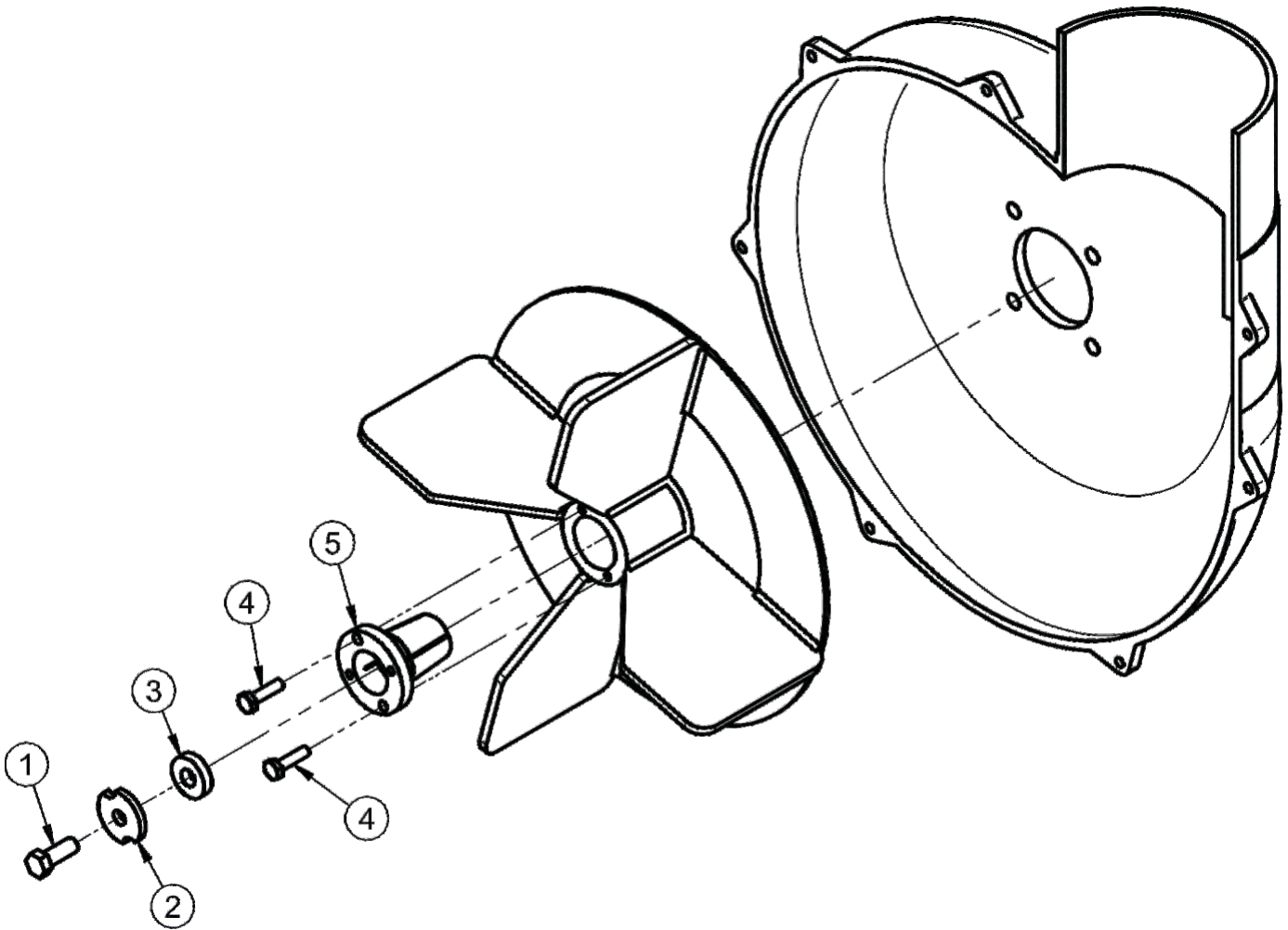

492005A X20 Trailer Vac Explosion

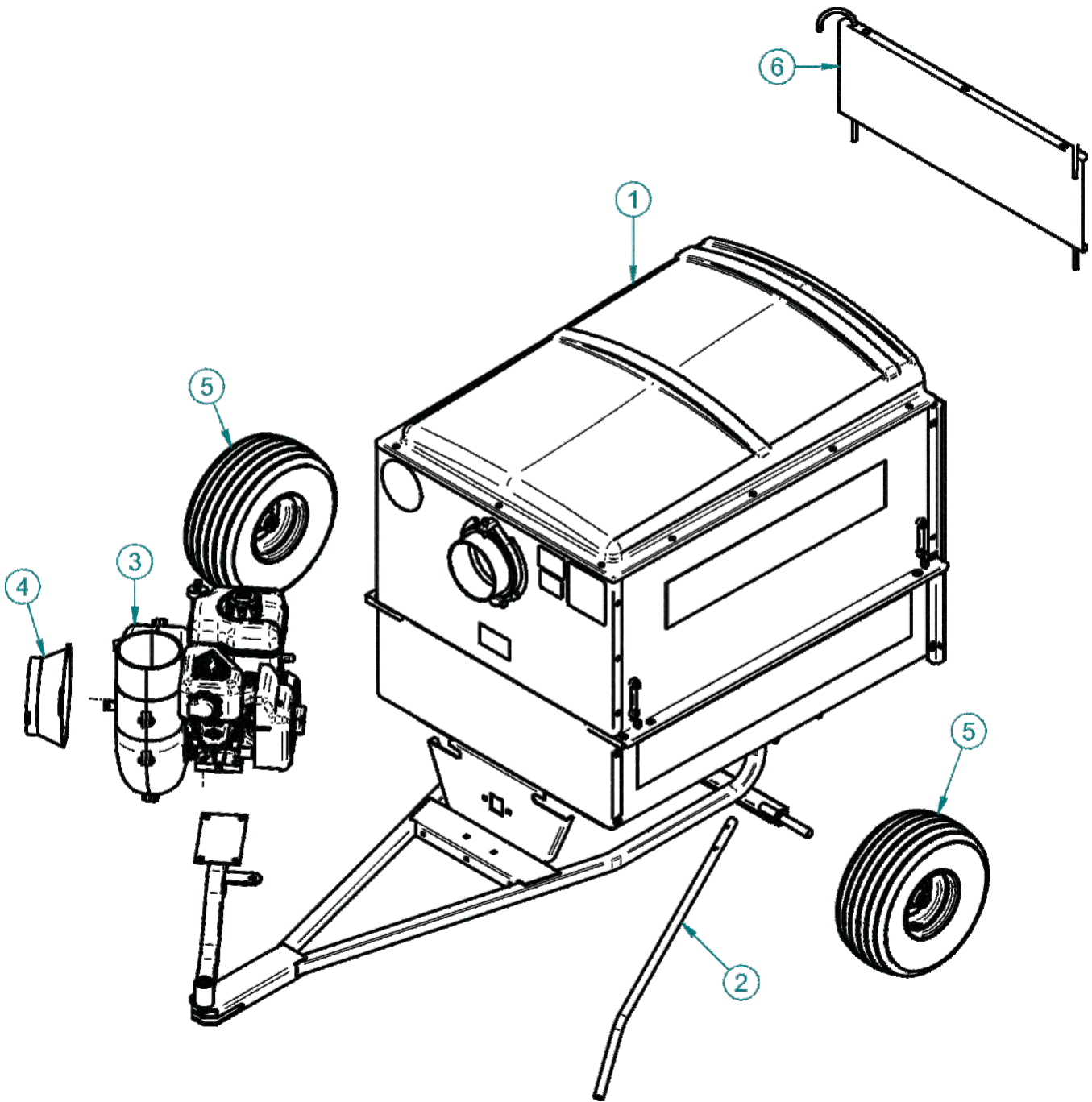

Item #	Part #	Desc.	Qty.
1	A1115	X20 Trailer Sub-Assy	1
2	B3492	DUMP HANDLE	1
3	A602	Briggs & Stratton 900 Series Blower / Blade Assy	1
4	E6004	7" BLOWER CONE	1
5	H5001	Wheel & Tire Assembly	2
6	A0262	Tail Gate Assembly	1

A1115 X20 Trailer Sub-Assy Explosion

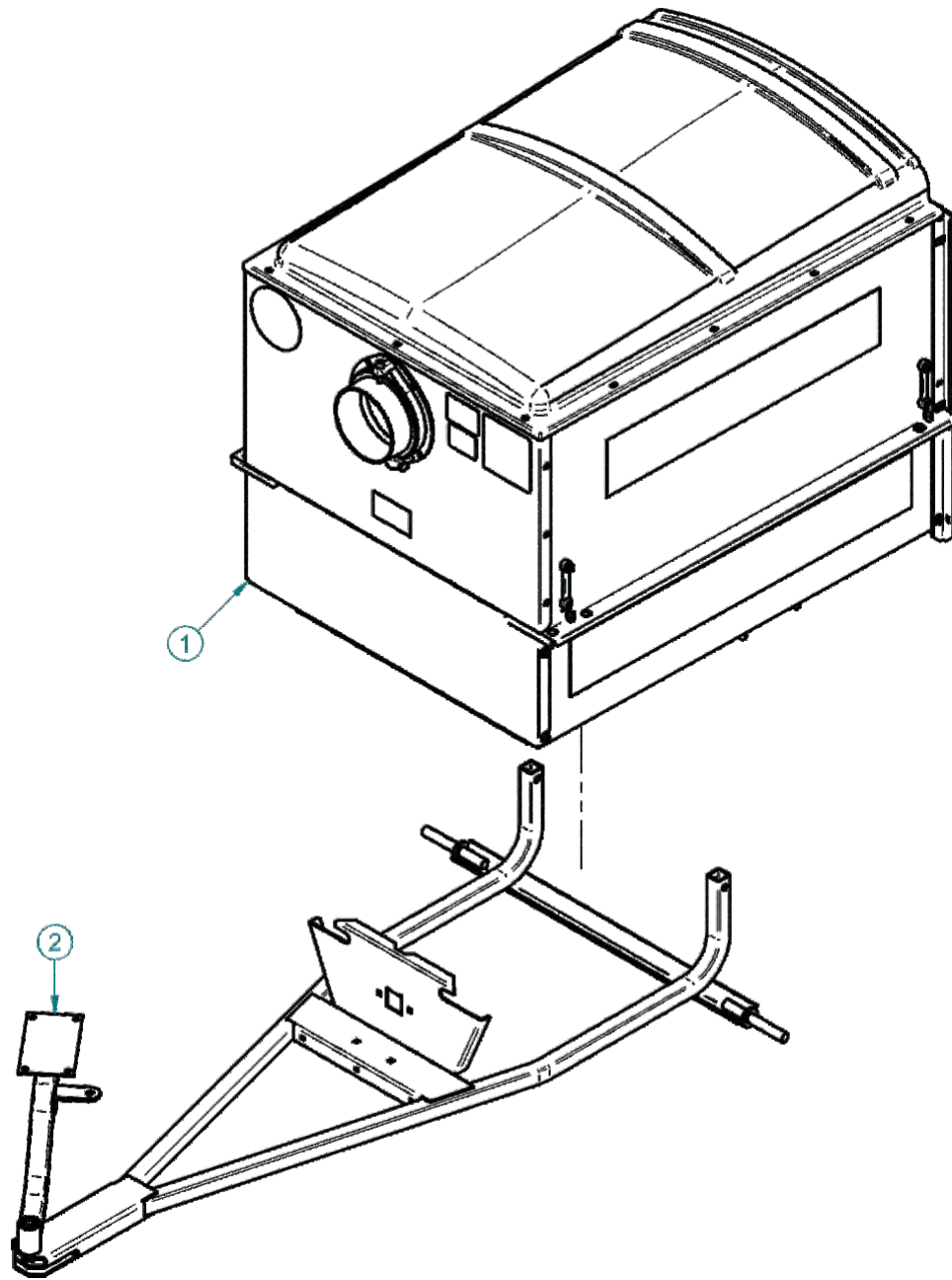

Item #	Part #	Desc.	Qty.
1	A2268	X20 Trailer / Top & Pan Sub-Assy	1
2	A2269	X20 Trailer / Chassis & Engine Mount Sub-Assy	1

A2268 Top & Pan Sub-Assy / X20 Trailer Vac Explosion

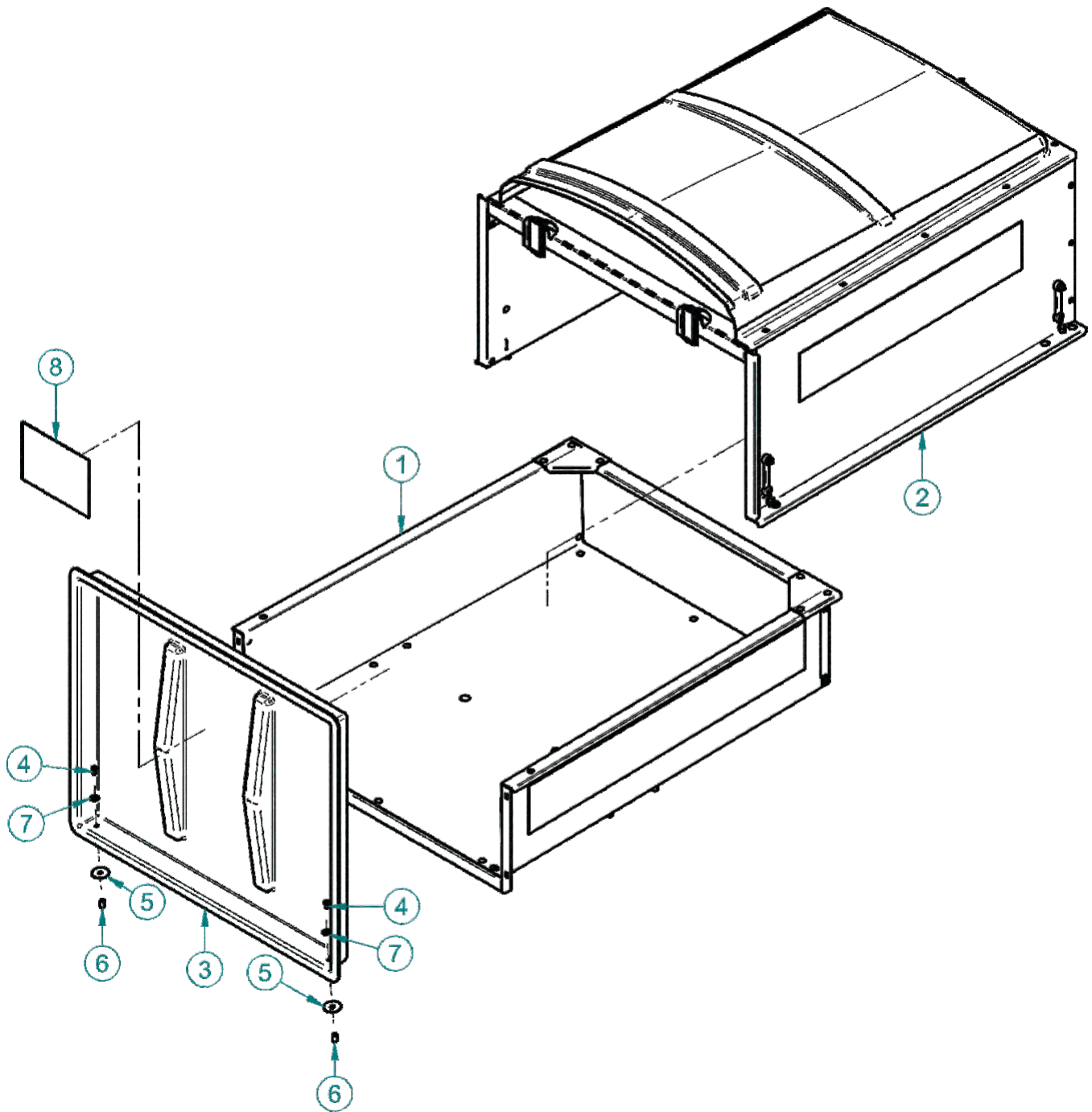

Item #	Part #	Desc.	Qty.
1	A1865	Pan Assembly / X20 Trailer	1
2	A1864	Top Assembly / X20 Trailer	1
3	V0001	Rear Door	1
4	K1105	1/4"-20 x 1/2" HHCS	2
5	K0041	5/16" FENDER WASHER 1.505 OD x .345 ID x .048 T	2
6	B4251	1/4"-20 LOCATOR PIN NUT	2
7	K0037	Flat Washer / 1/4" (.75 OD x .312 ID x .060 T)	2
8	R1070	Decal/ Peco Logo	1

A1864 Top Assy / X20 Trailer Vac Explosion

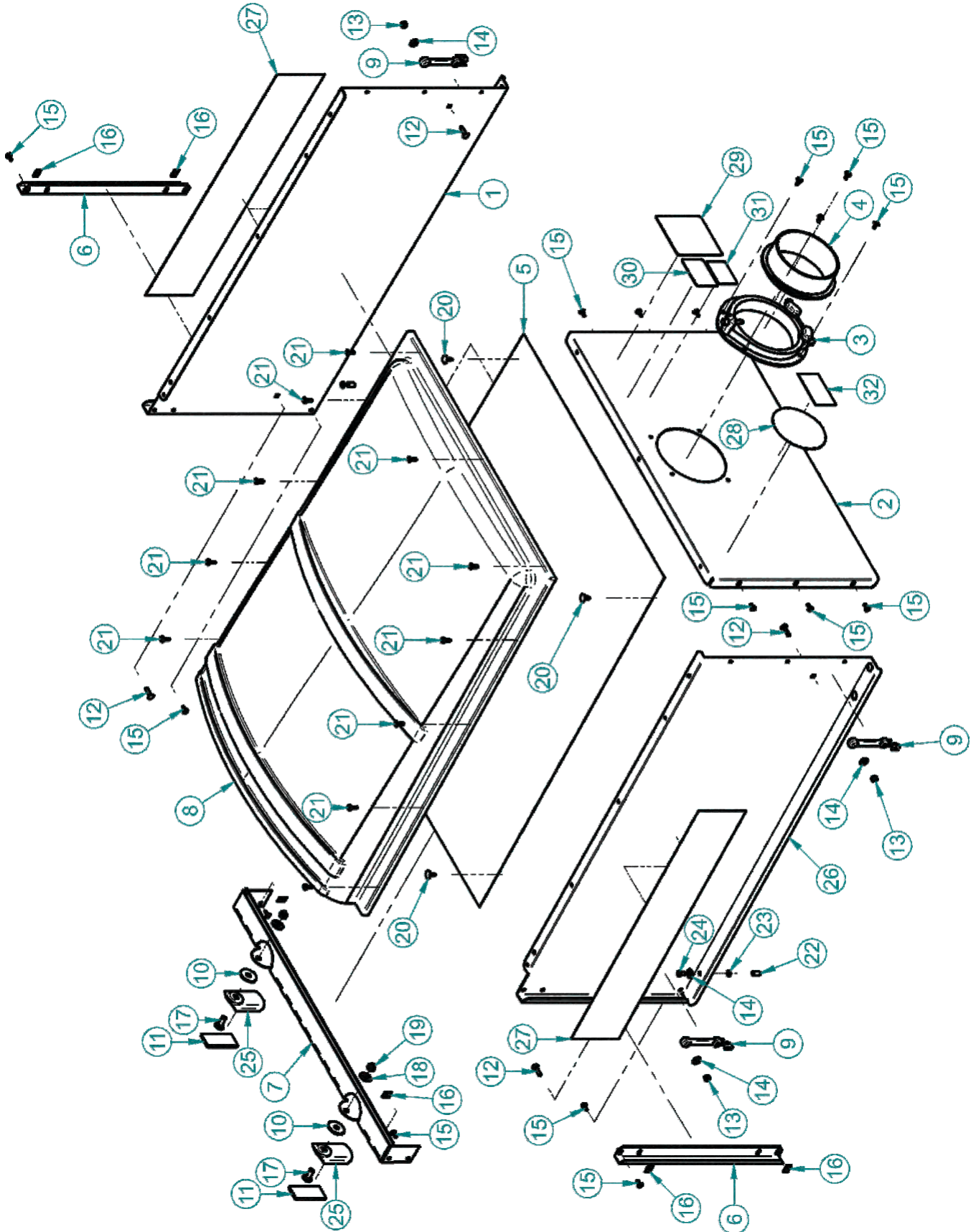

A1864 Top Assy / X20 Trailer Vac Explosion (Continued)

Item #	Part #	Desc.	Qty.
1	C0003	LEFT SIDE PANEL	1
2	C0004	FRONT SIDE PANEL	1
3	V1052	Inlet Ring w/ Locking Pin	1
4	E8010	6" INLET RING	1
5	B8135	FILTER SCREEN	1
6	C2135	SIDE PANEL BRACE	2
7	B0142	HEADER	1
8	V1023	PLASTIC TOP	1
9	J4009	Short Rubber Strap w/ S-Hook	4
10	J0541	1.50 OD x .406 ID x .125 T FRICTION WASHER	2
11	J0516	3.25 x 1.44 RED STICK-ON REFLECTOR	2
12	K1025	1/4"-20 x 1" CARRIAGE BOLT	4
13	K1128	1/4"-20 Nyloc Nut	4
14	K0037	Flat Washer / 1/4" (.75 OD x .312 ID x .060 T)	6
15	K1096	#10-12 x 1/2" Tinnerman Screw	16
16	K0029	#10-12 Flat Tinnerman Nut 3/4" x 1/2"	16
17	K1182	Carriage Bolt 3/8"-16 x 1"	2
18	K0047	Flat Washer 3/8" / 1.00 OD x .446 ID x .075 T	2
19	K1216	Nyloc Nut / 3/8"-16	2
20	K1265	Black Panel Retainer	4
21	K0010	#10-12 x 3/4" SHARP TIP SMS	11
22	B4251	1/4"-20 LOCATOR PIN NUT	2
23	K0039	1/4" Lock Washer	2
24	K1105	1/4"-20 x 1/2" HHCS	2
25	C1170	DOOR LATCH BRACKET	2
26	C0005	RIGHT SIDE PANEL	1
27	R1071	X20 Trailer Vac Label / 5" x 23"	2
28	R0022	Decal / Built In The USA / Lg	1
29	R1069	Decal / Warning - Turn Off Blower	1
30	R1054	Decal / Important Check Hoses	1
31	R1051	Decal / Warning - Use Hearing Protection	1
32	R1066	Decal/ Lock - Dump	1

A1865 Pan Assy / X20 Trailer Vac Explosion

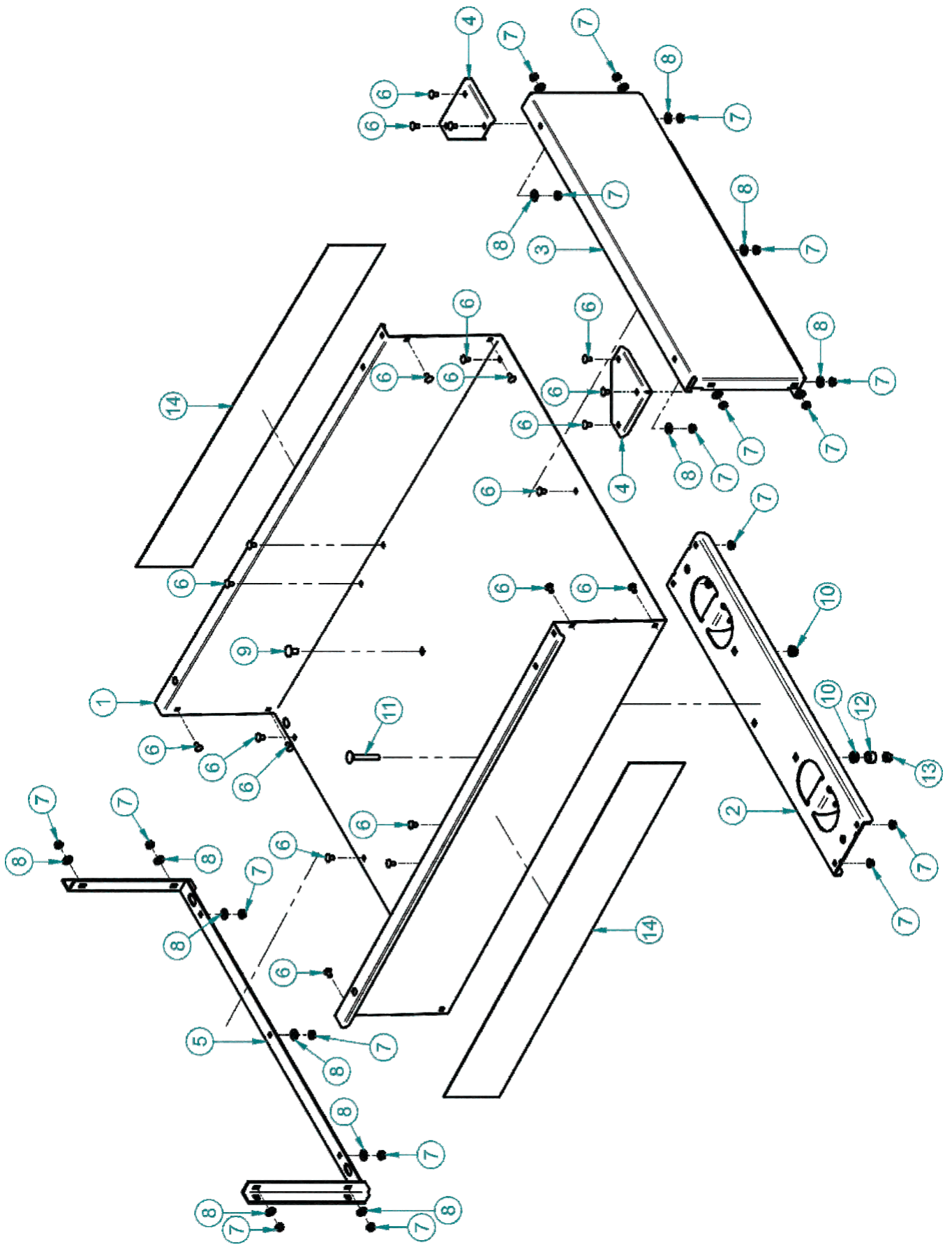

A1865 Pan Assy / X20 Trailer Vac Explosion (Continued)

Item #	Part #	Desc.	Qty.
1	B0134	PAN	1
2	B0136	Pivot Support	1
3	B0133	PAN FRONT	1
4	B0138	Pan Corner Brace	2
5	A0527	TAIL GATE BRACE ASSEMBLY	1
6	K1005	1/4"-20 x 1/2" Carriage Bolt	24
7	K1126	Flange Nut 1/4"-20	24
8	K0037	Flat Washer / 1/4" (.75 OD x .312 ID x .060 T)	20
9	K1181	3/8"-16 x 3/4" CARRIAGE BOLT	1
10	K1215	Flange Nut 3/8"-16	2
11	K1186	3/8"-16 x 2-1/2" CARRIAGE BOLT	1
12	S3143	.75 OD x .406 ID x .50 T SPACER BUSHING	1
13	K1216	Nyloc Nut / 3/8"-16	1
14	R0038	Decal / Peco Stripe / Lg	2

A2269 Chassis & Engine Mount Sub-Assy / X20 Trailer Vac Explosion

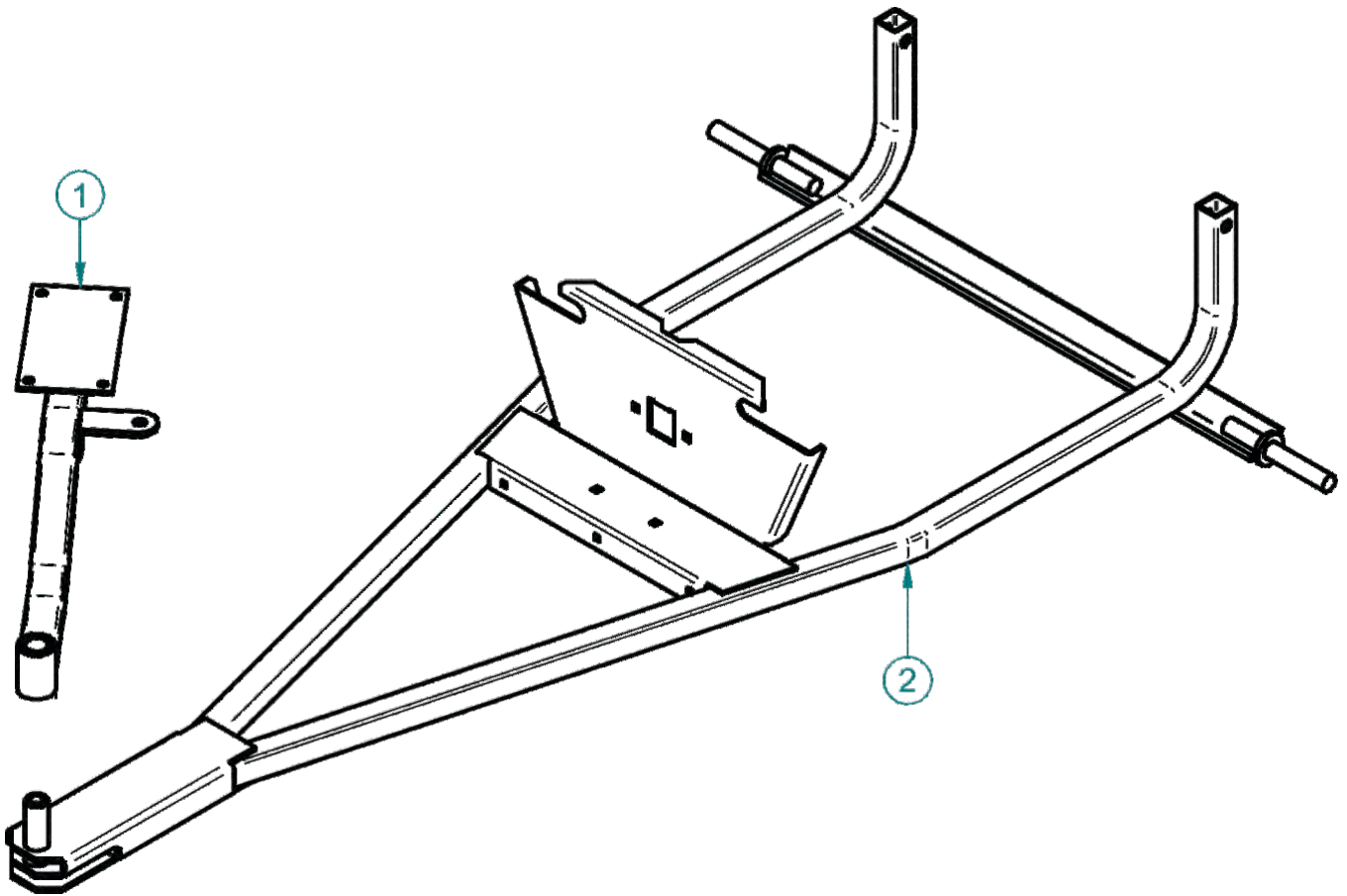

Item #	Part #	Desc.	Qty.
1	A0837	Eng. Mnt. Arm Assy.	1
2	A1866	Chassis Assembly / X20 Trailer	1

A0025 Engine Stay Assembly Kit Explosion

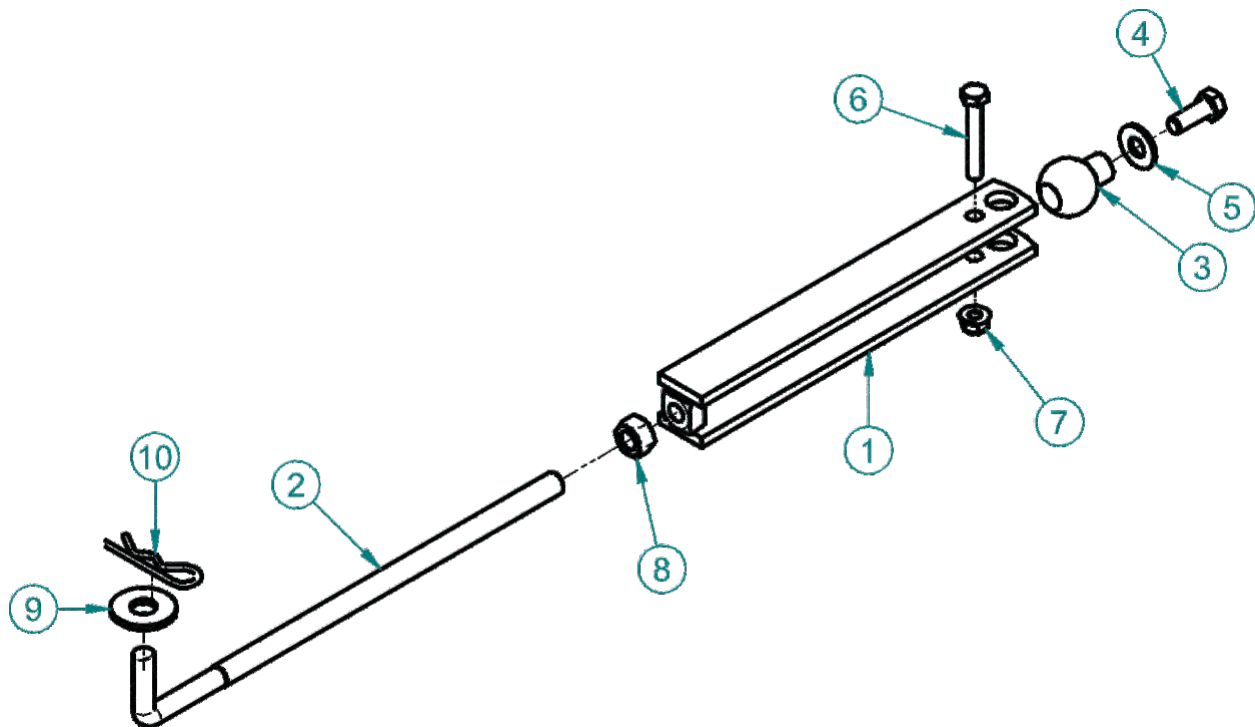

Item #	Part #	Desc.	Qty.
1	A0336	Ball Clevis Clamp Assembly	1
2	B4311	ADJUSTING ROD	1
3	B0132	Ball Clevis	1
4	K1191	HHCS 3/8"-16 x 1" GR5	1
5	K0047	Flat Washer 3/8" / 1.00 OD x .446 ID x .075 T	1
6	K1159	5/16"-18 x 2" All Thread HHCS	1
7	K2516	Ny-Flange Lock Nut 5/16"-18	1
8	K1243	1/2"-13 Hex Nut	1
9	K0055	Flat Washer 1/2" / 1.383 OD x .560 ID x .120 T	1
10	K0086	Hair Pin Clip .125 OD x 2.50	1

6930 X30 Trailer Vac Explosion

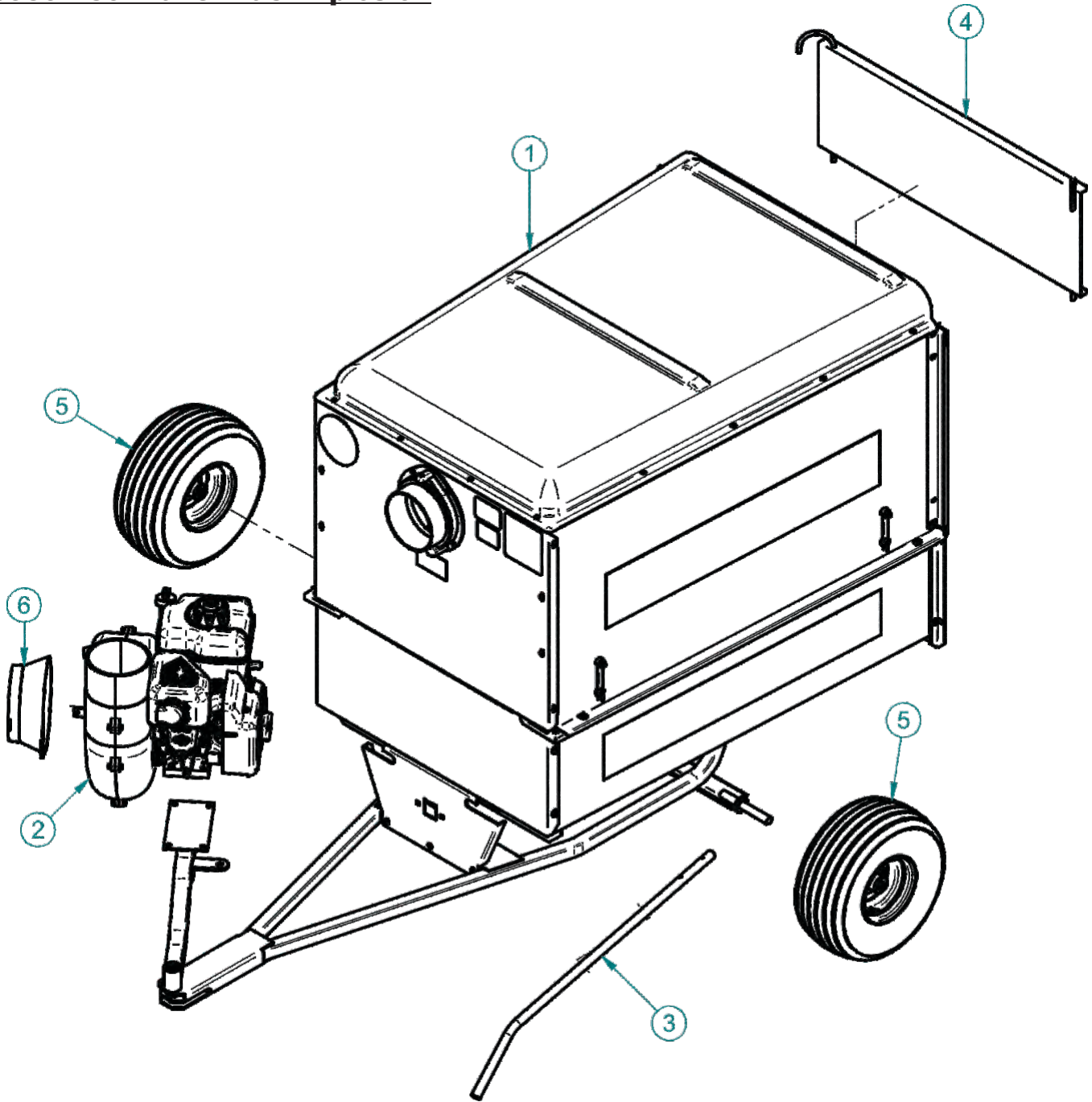

Item #	Part #	Desc.	Qty.
1	A1116	X30 Trailer Vac Sub-Assy	1
2	A602	Briggs & Stratton 900 Series Blower / Blade Assy	1
3	B3492	DUMP HANDLE	1
4	A0263	Tail Gate Assembly	1
5	H5001	Wheel & Tire Assembly	2
6	E6004	7" BLOWER CONE	1

A1116 X30 Trailer Sub-Assy Explosion

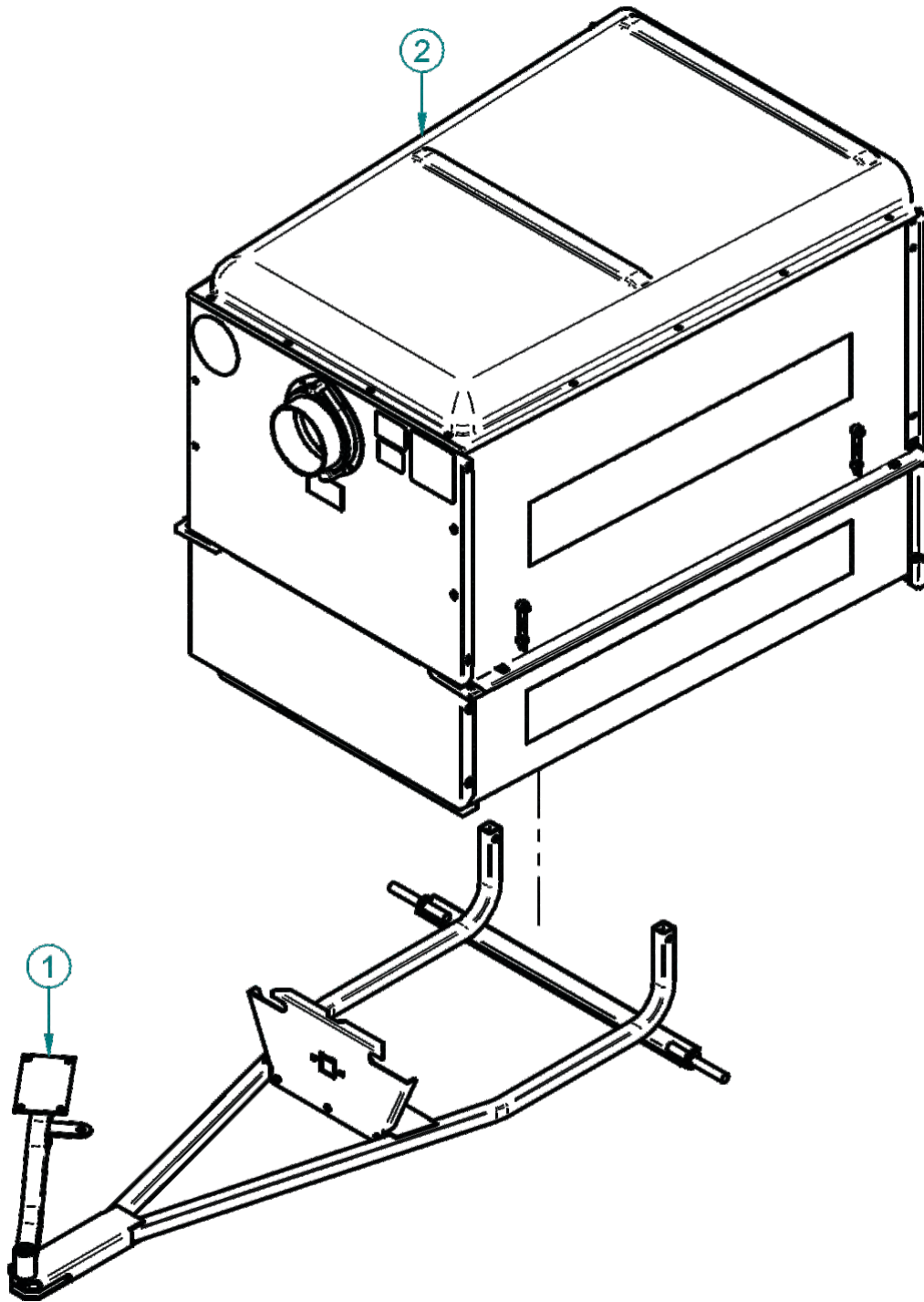

Item #	Part #	Desc.	Qty.
1	A2115	Chassis & Engine Mount Sub-Assy	1
2	A2271	X30 Trailer / Top & Pan Sub-Assy	1

A2271 Top & Pan Sub-Assy / X30 Trailer Explosion

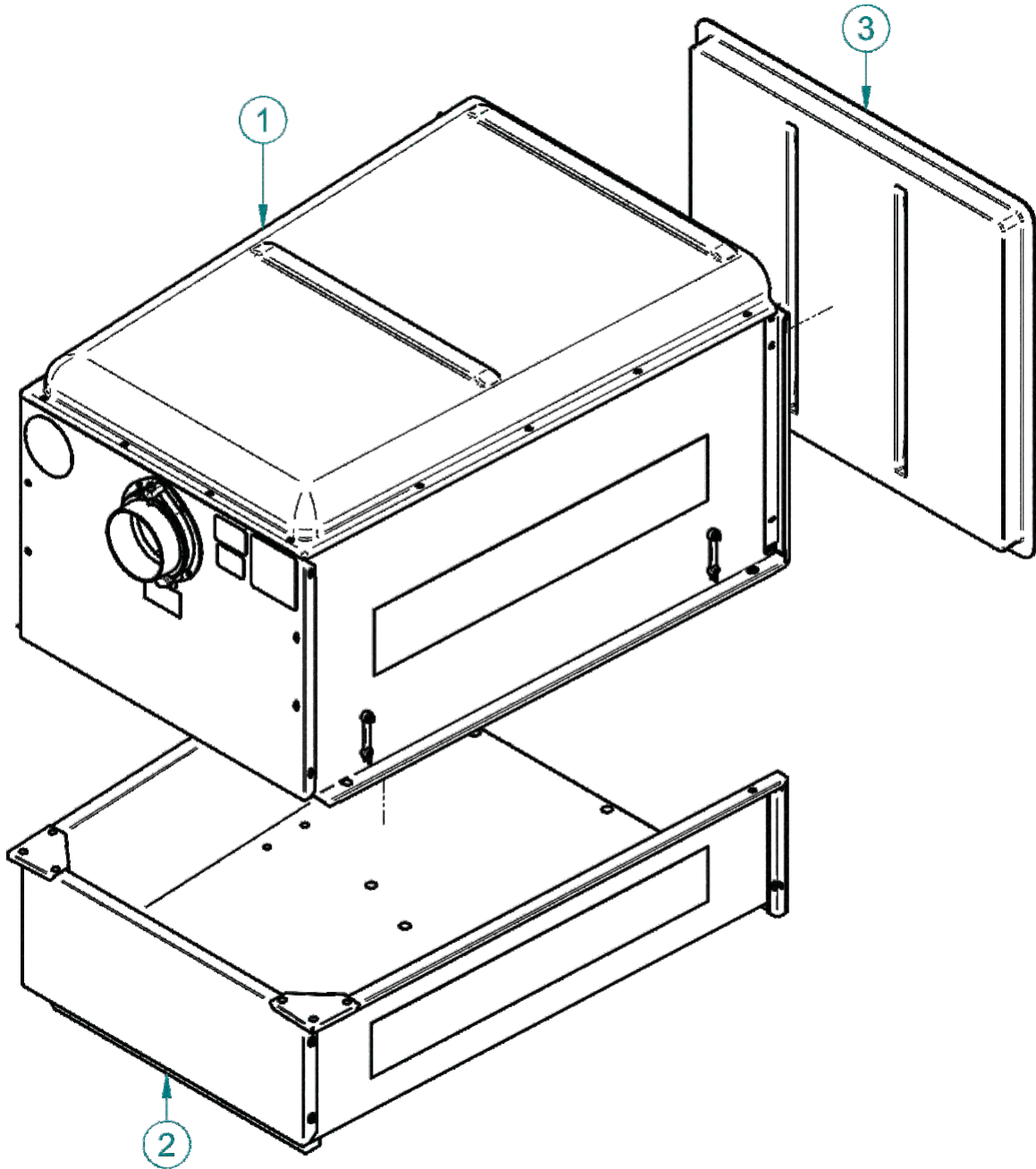

Item #	Part #	Desc.	Qty.
1	A2112	Top Assembly / X30 Trailer	1
2	A2113	Pan Assembly / X30 Trailer	1
3	A2114	Door Assembly / X30 Trailer	1

A2112 Top Assy / X30 Trailer Explosion

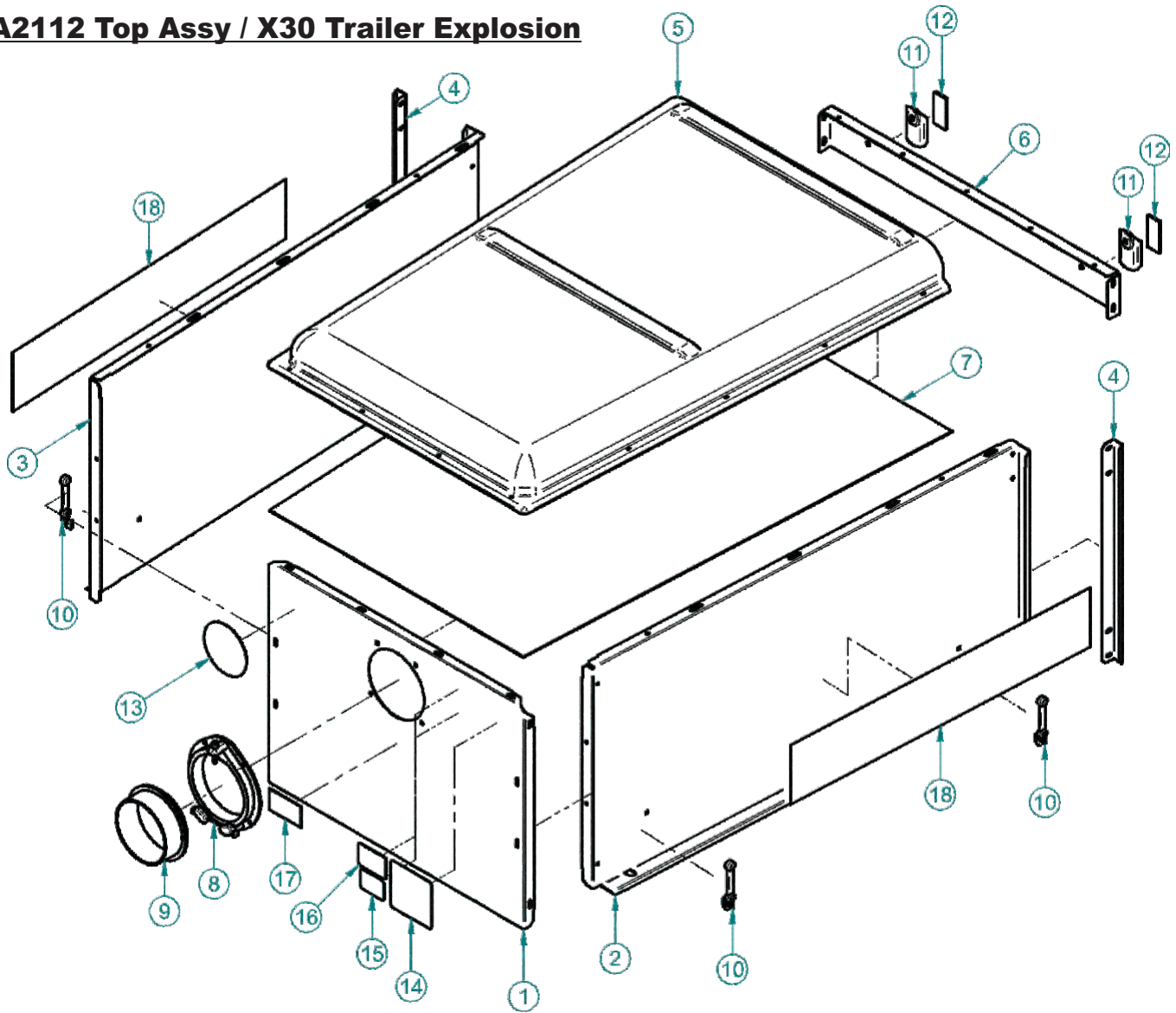

Item #	Part #	Desc.	Qty.
1	C0082	Front Panel	1
2	C0083	Left Side Panel	1
3	C0084	Right Side Panel	1
4	C0085	Side Panel Brace	2
5	V1021	Top	1
6	B1003	Header	1
7	B8136	30 Trailer Screen	1
8	V1052	Inlet Ring w/ Locking Pin	1
9	E8010	6" INLET RING	1
10	J4009	Short Rubber Strap w/ S-Hook	4
11	C1170	DOOR LATCH BRACKET	2
12	J0516	3.25 x 1.44 RED STICK-ON REFLECTOR	2
13	R0022	Decal / Built In The USA / Lg	1
14	R1069	Decal / Warning - Turn Off Blower	1
15	R1051	Decal / Warning - Use Hearing Protection	1
16	R1054	Decal / Important Check Hoses	1
17	R1066	Decal/ Lock - Dump	1
18	R0029	Decal / 30 cu. ft. Trailer Vac	2

A2113 Pan Assy / X30 Trailer Explosion

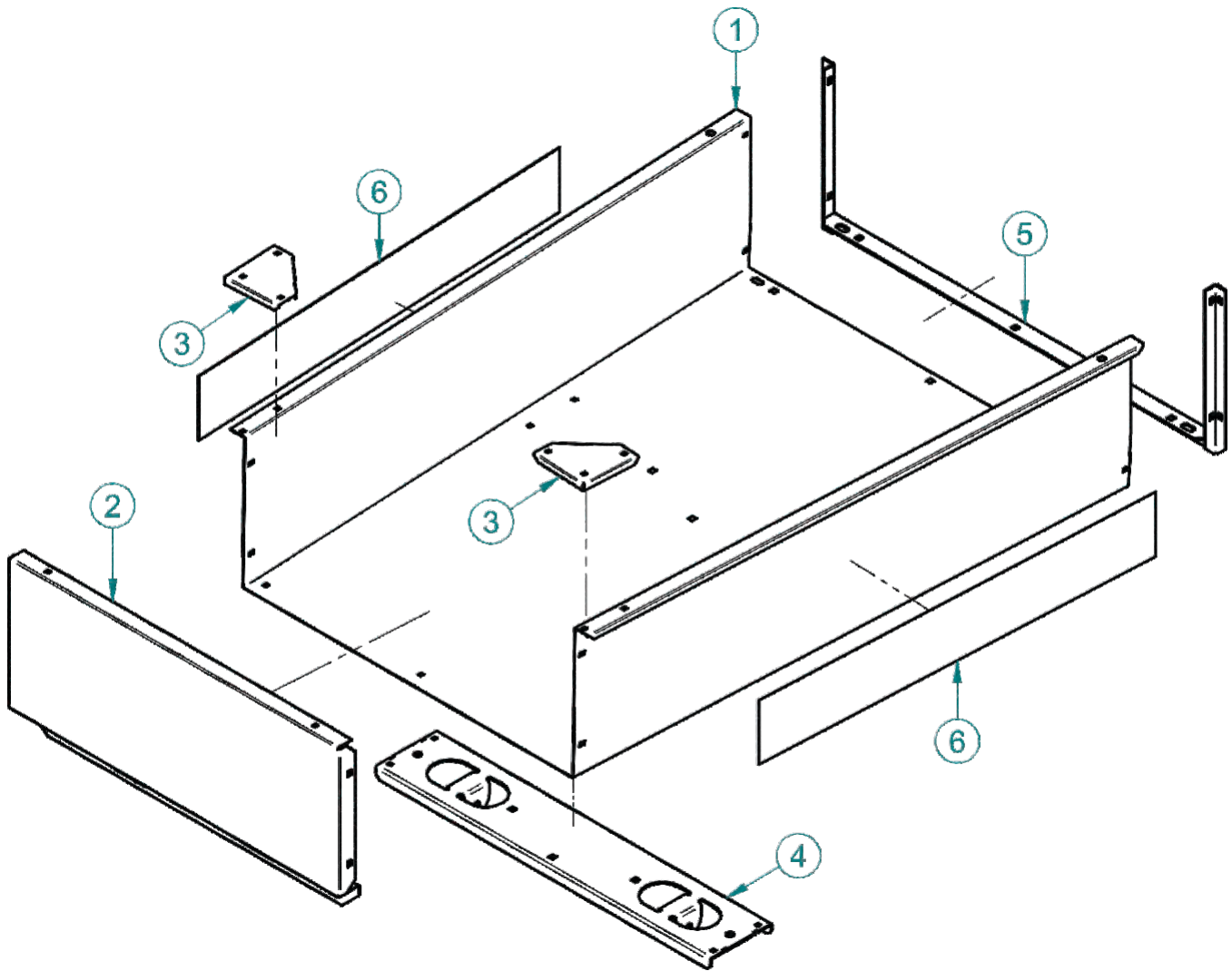

Item #	Part #	Desc.	Qty.
1	B1001	Pan	1
2	B1002	Pan Front	1
3	B0138	Pan Corner Brace	2
4	B0136	Pivot Support	1
5	A2099	Pan Door Brace Weldment	1
6	R0038	Decal / Peco Stripe / Lg	2

A2114 Door Assy / X30 Trailer Explosion

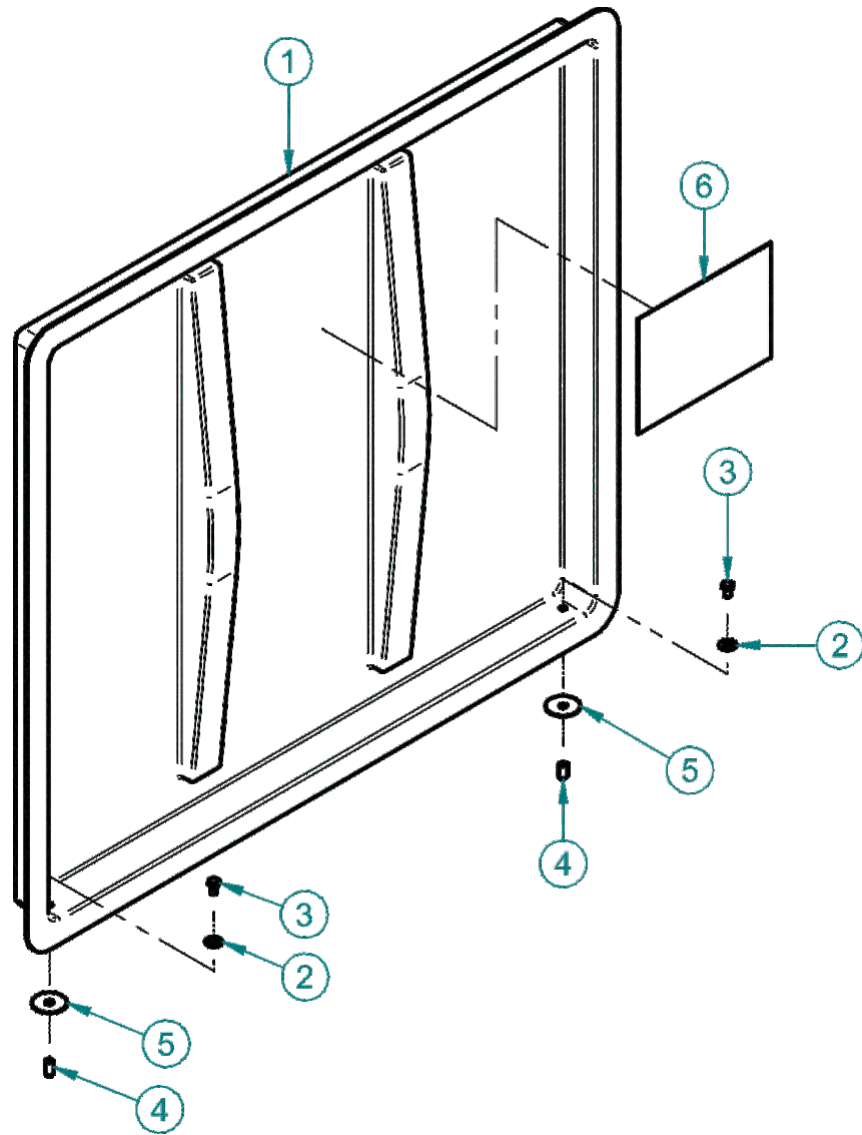

Item #	Part #	Desc.	Qty.
1	V1041	Door	1
2	K0037	Flat Washer / 1/4" (.75 OD x .312 ID x .060 T)	2
3	K1105	1/4"-20 x 1/2" HHCS	2
4	B4251	1/4"-20 LOCATOR PIN NUT	2
5	K0041	5/16" FENDER WASHER 1.505 OD x .345 ID x .048 T	2
6	R1070	Decal/ Peco Logo	1

A2115 Chassis & Engine Mount Sub-Assy / X30 Trailer Explosion

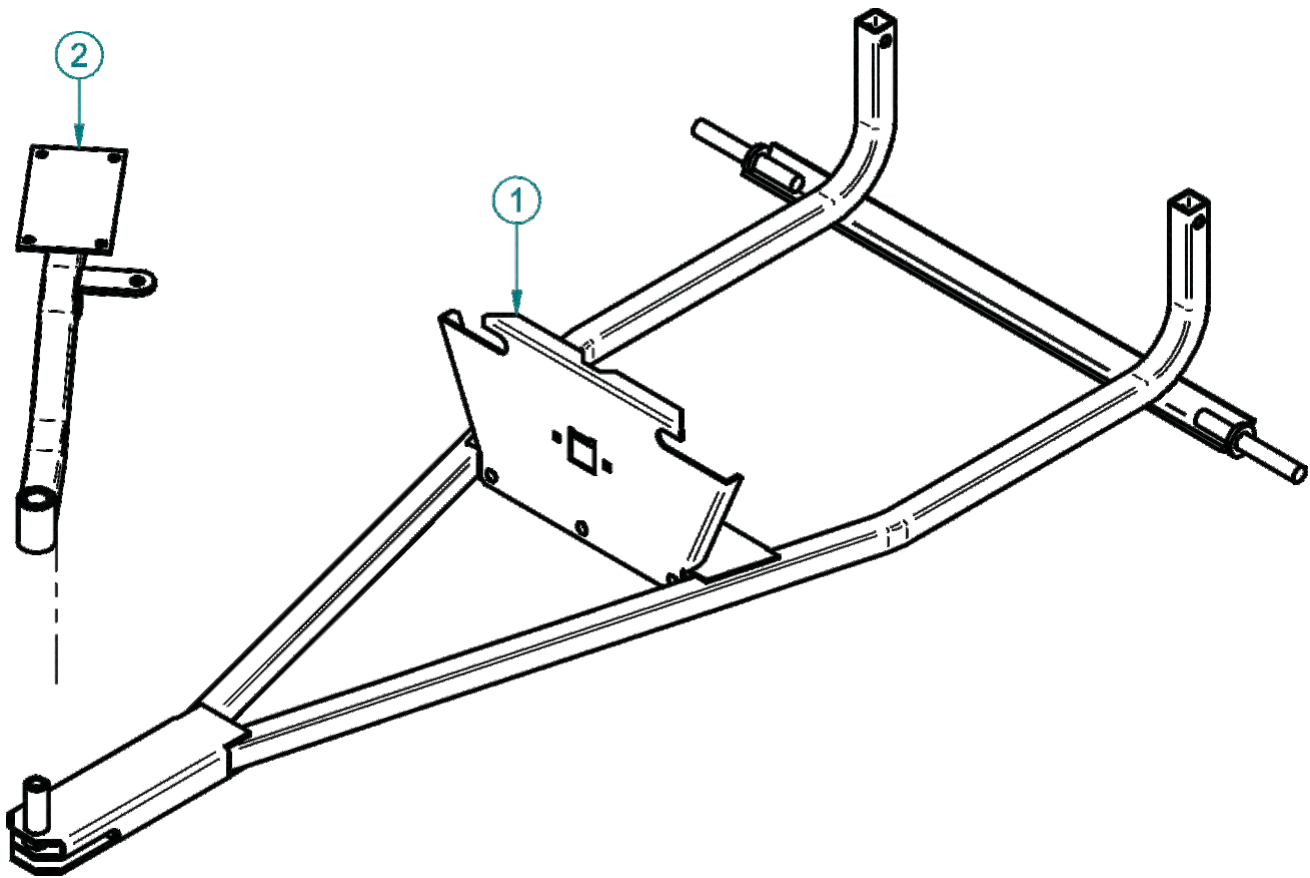

Item #	Part #	Desc.	Qty.
1	A2270	X30 Trailer / Chassis Sub-Assy	1
2	A0837	Eng. Mnt. Arm Assy.	1

Unit Model #: 4920

Mower: **Owner's Manual: Q0547**

Mower Type:

Deck Size:

Deck Type:

Revision #: 1 - Updated on 08/30/2019 - XY

Vac Type: X20 Trailer Vac

Drive Type: Briggs & Stratton 900 Series

Fits Year(s): 2013 & Newer



Crate Contents

Components Box Contents

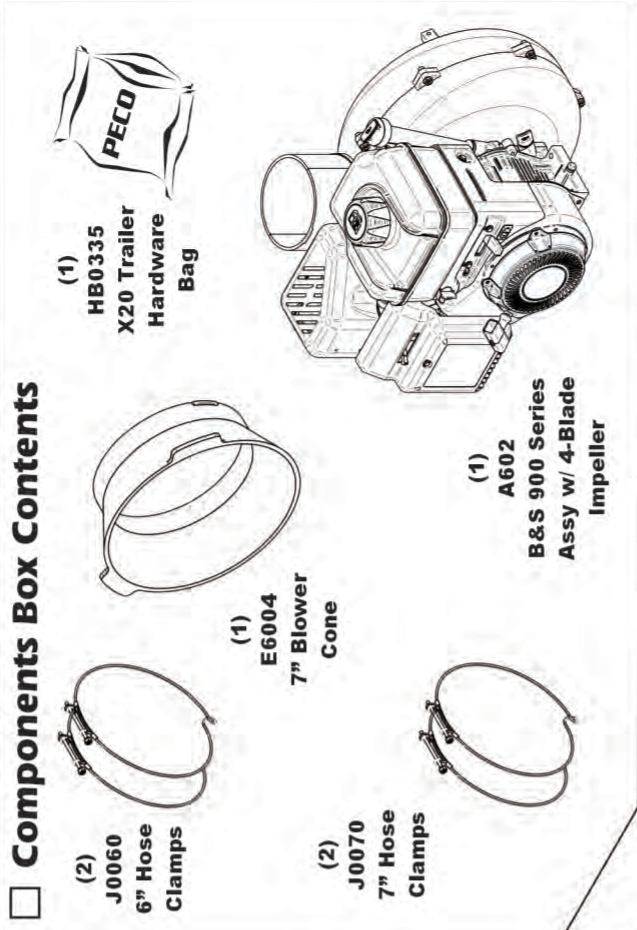

The contents below are placed inside of the X20 Trailer Sub-Assy

(1) F0070-66 7" x 66" Lower Hose

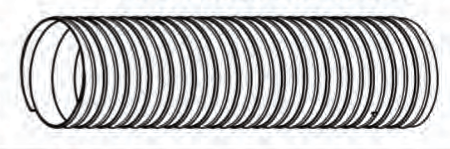

(1) F0060-60 6" x 60" Upper Hose



(1) A0262 Tail Gate Assy

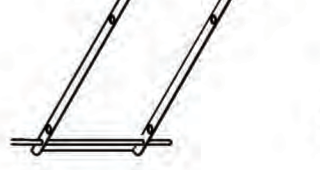

(2) H5001 Wheel & Tire

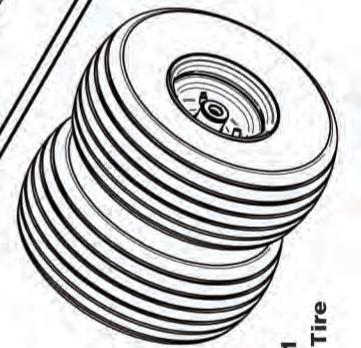

(1) B3492 Dump Handle

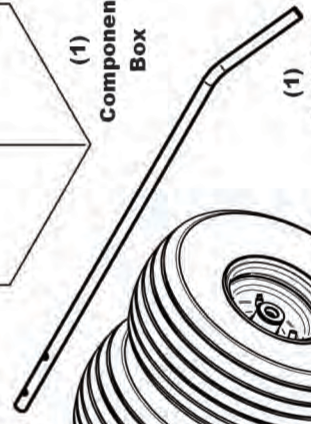

(1) Components Box

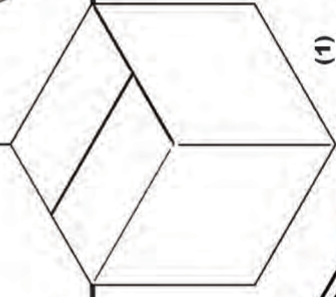

A0121 Small Universal Boot Kit

(1) A0849 Boot Kit HW Bag



(1) V1018 Universal Boot / Small



A0137 Large Universal Boot Kit

(1) A0856 Boot Kit HW Bag



(1) V1049 Universal Boot / Large

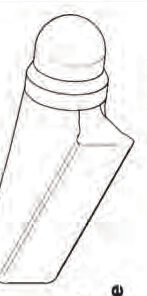

Unit Model #: 5920

Mower:

Owner's Manual: Q0547

Mower Type:

Vac Type: X20 Trailer Vac

Deck Size:

Drive Type: 6.5HP Briggs & Stratton Vanguard

Deck Type:

Fits Year(s): 2013 & Newer

Revision #: 1 - Updated on 08/30/2019 - XY



Crate Contents

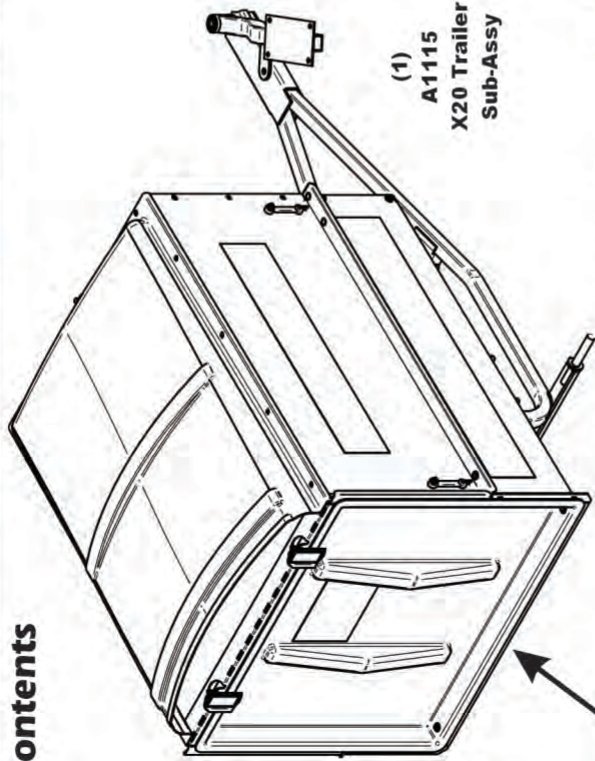

Components Box Contents

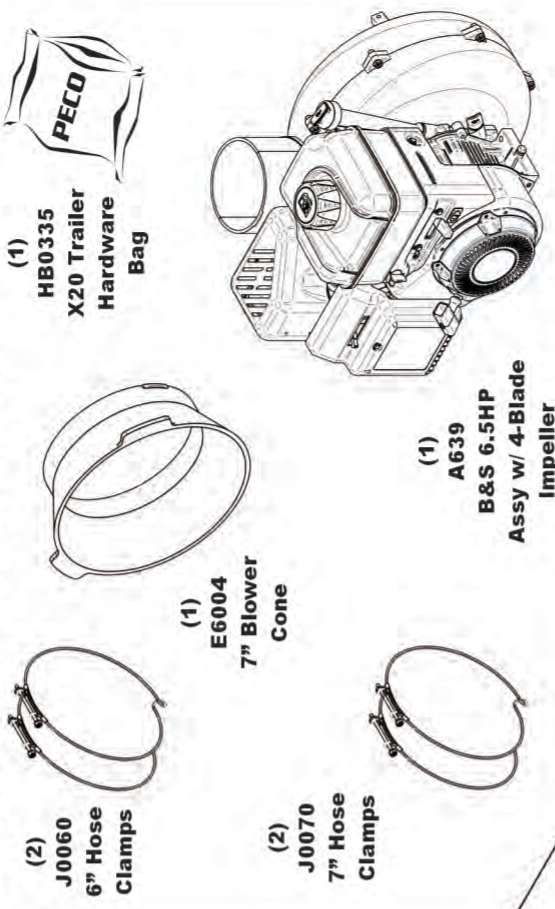

The contents below are placed inside of the X20 Trailer Sub-Assy

(1) F0070-66 7" x 66" Lower Hose

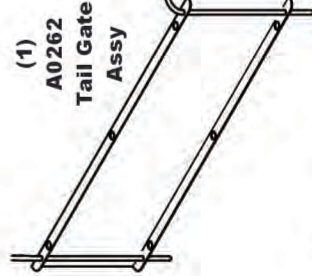
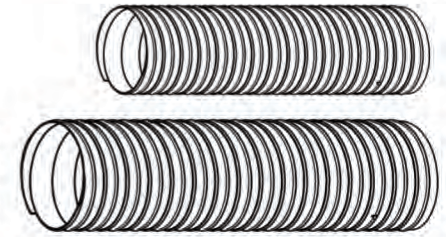

(2) H5001 Wheel & Tire

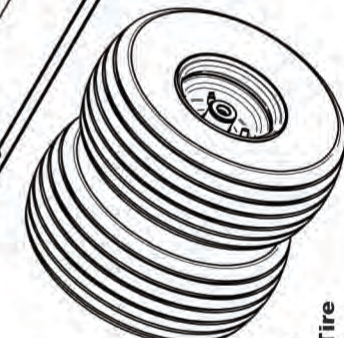

(1) B3492 Dump Handle



(1) Components Box

A0121 Small Universal Boot Kit



(1) V1018 Universal Boot / Small

A0137 Large Universal Boot Kit



(1) V1049 Universal Boot / Large

Unit Model #: 6930

Mower:

Owner's Manual: Q0547

Mower Type:

Vac Type: X30 Trailer Vac

Deck Size:

Drive Type: Briggs & Stratton 900 Series

Deck Type:

Fits Year(s): 2013 & Newer

Revision #: 1 - Updated on 09/10/2019 - XY

Crate Contents

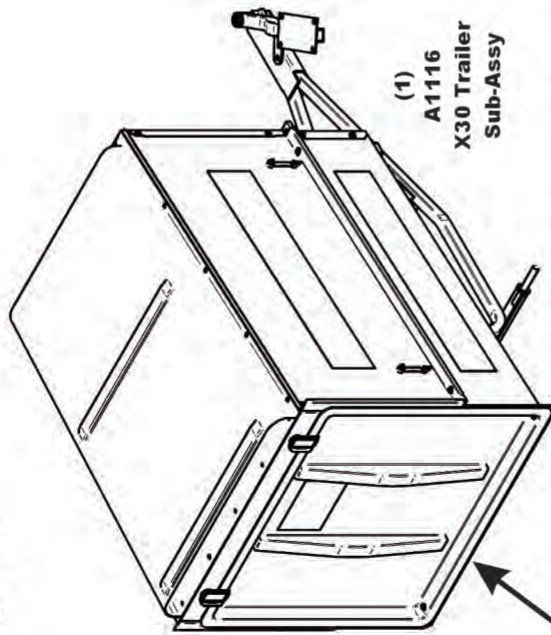

Components Box Contents

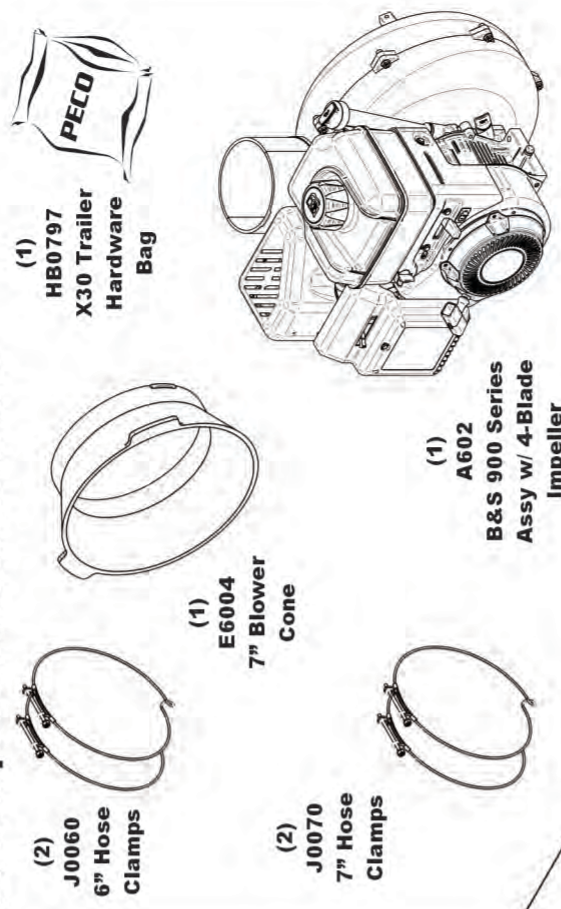

The contents below are placed inside of the X30 Trailer Sub-Assy

(1)
F0070-66
7" x 66"
Lower Hose

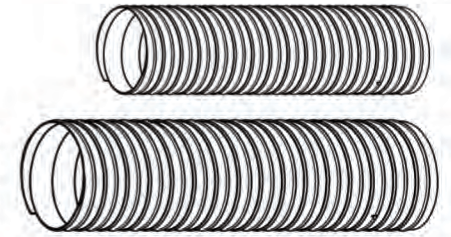

(1)
F0060-60
6" x 60"
Upper Hose

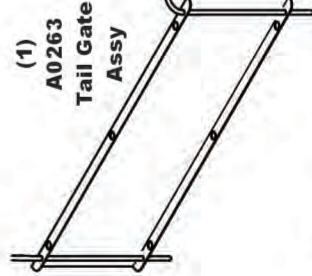

(2)
H5001
Wheel & Tire

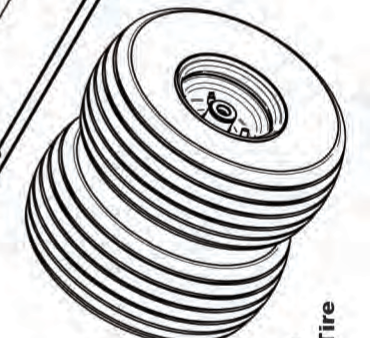

(1)
B3492
Dump
Handle

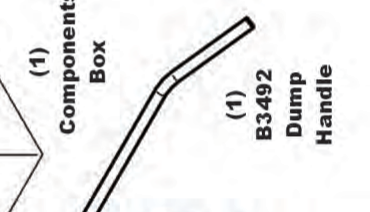

(1)
Components
Box

A0121 Small Universal Boot Kit

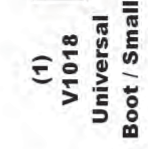

A0137 Large Universal Boot Kit



Unit Model #: 7930

Mower: **Owner's Manual: Q0547**

Mower Type:

Deck Size:

Deck Type:

Revision #: 1 - Updated on 09/10/2019 - XY

Vac Type: X30 Trailer Vac

Drive Type: 6.5HP Briggs & Stratton Vanguard

Fits Year(s): 2013 & Newer



Crate Contents

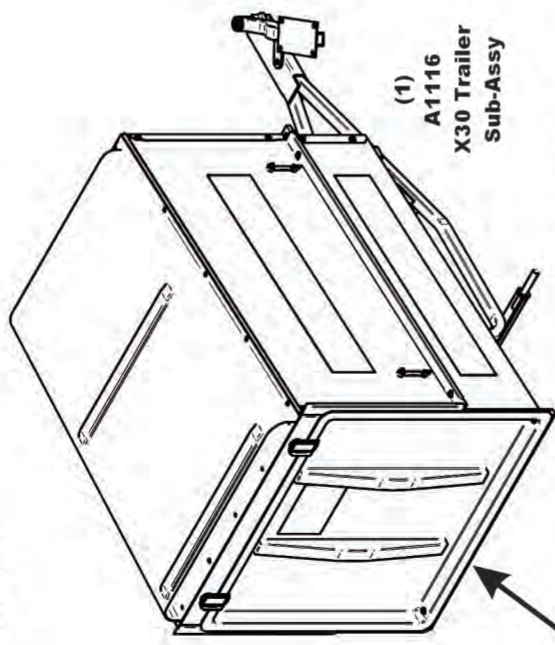

Components Box Contents

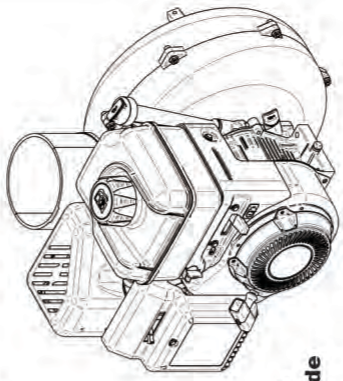
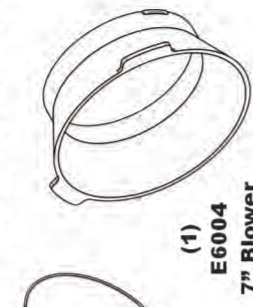

The contents below are placed inside of the X30 Trailer Sub-Assy

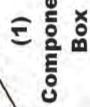
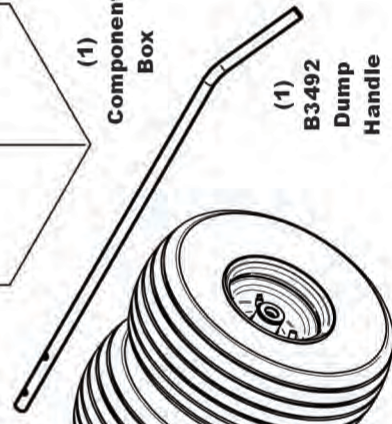
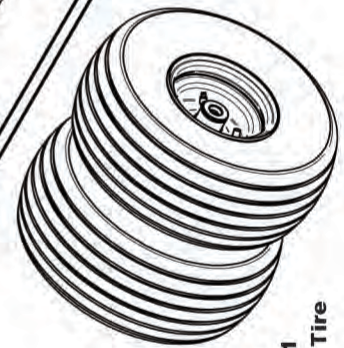
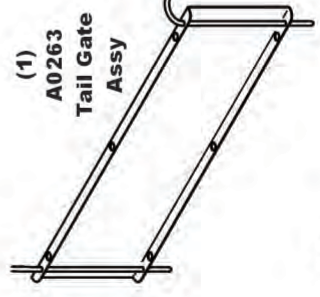
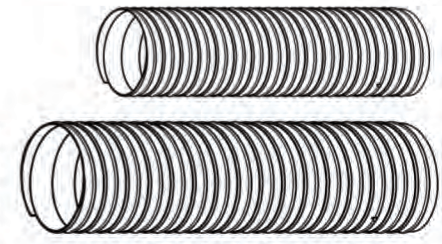
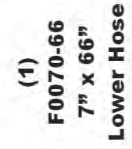

A0121 Small Universal Boot Kit

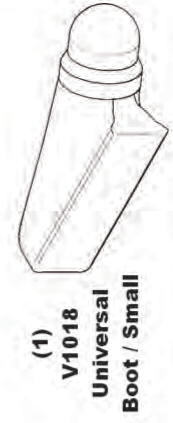

A0137 Large Universal Boot Kit

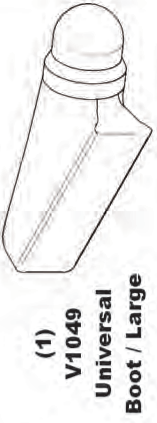

SAFETY DECALS

To promote safe operation, New PECO, Inc. supplies safety decals on all products manufactured. Damage can occur to safety decals either through shipment, use or reconditioning. Contact your local Service Center for replacement decals.



Part# R1070
PECO Logo



Part# R0022
Designed & Built
In The USA



Part #: R2007
Danger - Never Use Hands



Part #: R2008
Danger - Rotating Blades



Part #: R1054
Important - Hose Wear

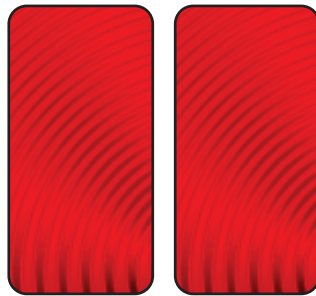

Part #: J0516 - (2)
Red Reflectors



Part #: R1069
Warning - Turn Off Blower



Part # R0024
Danger - Keep Hands
Clear



Part #: R1051
Warning - Hearing Protection



Part # R0025
Danger - Rotating
Blades

SECTION III OPERATING INSTRUCTIONS

General Safety

Only qualified people familiar with this operator's manual and the mower's operator's manual should operate this machine.

Operation And Tips On Mowing

- A. Perform BEFORE EACH USE the maintenance list referenced in Section IV.
- B. Start the engine/blower/blade assembly.
- C. Start mower.
- D. With the mower at high idle speed, engage the mower deck.
- E. Proceed to operate the control levers of the mower.

NOTE: If the collection system does not appear to be collecting the grass clippings, disengage the deck and PTO assembly, then, engage the parking brake and turn the mower off. Check upper and lower hoses for any clogs.

To obtain the maximum effectiveness from your collection system, the tips listed below should be followed:

- * Watch your speed- Normal conditions will allow a speed of up to approximately 4 mph, but thick, heavy damp conditions will require reduced ground speed.
- * Mow with sharp blades- A sharp blade cuts cleaner.
- * Wet grass and leaves will decrease effectiveness and will increase horsepower requirements.
- * Mow at higher cutting heights- Remove and mulch no more than 2" of grass length with each mowing. (Experts recommend not cutting off more than 1/3 of the grass blade length at any given time.)
- * Mow twice, at different height settings, (high, then low), if grass is extra tall.
- * Remember that horsepower requirements will vary with the mowing conditions such as type and height of turf grass, moisture content, amount of leaves, whether the terrain is flat or hilly, etc.

Unloading The Collection System

NOTE: Collection system blower will have an audible change in tone when the collection system is full.

- A. Stop the forward movement of the mower.
- B. Disengage the mower deck.
- C. Engage the parking brake.

- D. Once the parking brake has been engaged, then and only then, walk back and turn off the collection system blower.
- E. Detach the upper hose from the inlet mount.
- F. Remove the trailer door.
- G. Unlock and lift the handle to pivot the container towards the ground. The container will then release its contents.
- H. Once the contents of the container have fallen out, the container is ready to move back into its normal operating position. Pull the handle downward and return the handle into the locked position. Then re-attach the trailer door and the upper hose.

NOTE: Do not allow the container to become over-filled as potential damage may occur to your equipment. Also, be sure to clean the hood screen as needed.

SECTION IV MAINTENANCE

Maintenance Checklist

Before each use:

1. Check blades and spindles to be sure that no foreign objects, such as wire or steel strapping bands, are wrapped around them.
2. Inspect blades for wear. Replace if necessary. If it is necessary to sharpen the blades, remove the blades from the spindles before sharpening. DO NOT sharpen blades while still attached to the mower.
3. Make sure all shields are in place and in good condition. Repair or replace any missing or damaged shields.
4. Listen for abnormal sounds, which might indicate loose parts, damaged bearings, or other damage. Correct any deficiency before continuing operation.
5. Check for wear or deterioration of the upper or lower hoses. If there are any portions of the hose that have been torn or worn through, replace immediately.

After Each Use:

1. Clean all debris from machine especially from the container, and safety decals. Replace any missing or illegible decals.
2. Inspect the unit for worn or damaged components. Repair or replace before the next use. Any replacement component installed during repair shall include the component's current safety decal specified by the manufacturers to be affixed to the component.

SECTION V PARTS & SERVICE

Parts And Service Information

Collection system owners should record the name and telephone number of their Service Center. Your Service Center will be happy to supply replacement parts, accessories, and do any service or repairs to your collection system. If for any reason your Service Center is unable to service your collection system or supply replacement parts, contact New PECO, Inc. and include the following information on the chart below.

DOCUMENT THE FOLLOWING INFORMATION FOR FUTURE REFERENCE

Unit Model Number: _____

Unit Engine Size: _____

Unit Serial Number: _____

Date of purchase: ____ / ____ / ____

Dealer/Distributor Name: _____

Address: _____ **State:** _____ **Zip:** _____

Phone Number: _____

New PECO, Inc.
10 Walden Dr | Arden, North Carolina 28704
Phone: 1-800-438-5823 | 828-684-1234
Fax: 828-684-0858
Email: peco@lawnvac.com
Website: www.lawnvac.com

TORQUE SPECIFICATIONS

Proper torque for American fasteners used on PECO equipment.
Recommended Torque in Foot Pounds (Newton Meters).*

AMERICAN Bolt Head Markings

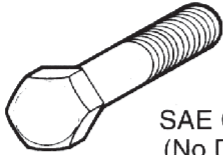

SAE Grade 2
(No Dashes)

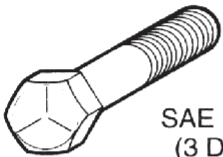

SAE Grade 5
(3 Dashes)

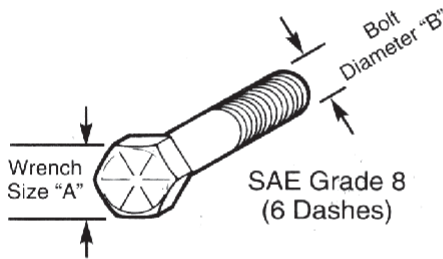

SAE Grade 8
(6 Dashes)

WRENCH SIZE (IN.) "A"	BOLT DIAMETER (IN.) "B" AND THREAD SIZE	SAE GRADE 2	SAE GRADE 5	SAE GRADE 8
7/16	1/4 - 20 UNC	6 (7)	8 (11)	12 (16)
7/16	1/4 - 28 UNF	6 (8)	10 (13)	14 (18)
1/2	5/16 - 18 UNC	11 (15)	17 (23)	25 (33)
1/2	5/16 - 24 UNF	13 (17)	19 (26)	27 (37)
9/16	3/8 - 16 UNC	20 (27)	31 (42)	44 (60)
9/16	3/8 - 24 UNF	23 (31)	35 (47)	49 (66)
5/8	7/16 - 14 UNC	32 (43)	49 (66)	70 (95)
5/8	7/16 - 20 UNF	36 (49)	55 (75)	78 (106)
3/4	1/2 - 13 UNC	49 (66)	76 (103)	106 (144)
3/4	1/2 - 20 UNF	55 (75)	85 (115)	120 (163)
7/8	9/16 - 12 UNC	70 (95)	109 (148)	153 (207)
7/8	9/16 - 18 UNF	79 (107)	122 (165)	172 (233)
15/16	5/8 - 11 UNC	97 (131)	150 (203)	212 (287)
15/16	5/8 - 18 UNF	110 (149)	170 (230)	240 (325)
1-1/8	3/4 - 10 UNC	144 (195)	266 (360)	376 (509)
1-1/8	3/4 - 16 UNF	192 (260)	297 (402)	420 (569)
1-5/16	7/8 - 9 UNC	166 (225)	430 (583)	606 (821)
1-5/16	7/8 - 14 UNF	184 (249)	474 (642)	668 (905)
1-1/2	1 - 8 UNC	250 (339)	644 (873)	909 (1232)
1-1/2	1 - 12 UNF	274 (371)	705 (955)	995 (1348)
1-1/2	1 - 14 UNF	280 (379)	721 (977)	1019 (1381)
1-11/16	1-1/8 - 7 UNC	354 (480)	795 (1077)	1288(1745)
1-11/16	1-1/8 - 12 UNF	397 (538)	890 (1206)	1444 (1957)
1-7/8	1-1/4 - 7 UNC	500 (678)	1120 (1518)	1817 (2462)
1-7/8	1-1/4 - 12 UNF	553 (749)	1241 (1682)	2013 (2728)
2-1/16	1-3/8 - 6 UNC	655 (887)	1470 (1992)	2382 (3228)
2-1/16	1-3/8 - 12 UNF	746 (1011)	1672 (2266)	2712 (3675)
2-1/4	1-1/2 - 6 UNC	870 (1179)	1950 (2642)	3161 (4283)
2-1/4	1-1/2 - 12 UNF	979 (1327)	2194 (2973)	3557 (4820)

METRIC

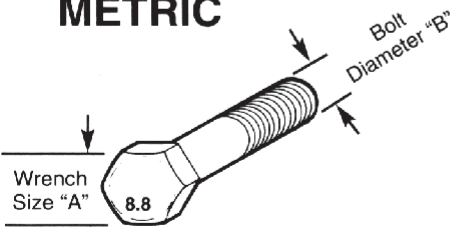

Numbers appearing on bolt heads indicate ASTM class.

Proper torque for metric fasteners used on PECO equipment.
Recommended torque in foot pounds (newton Meters).*

WRENCH SIZE (mm) "A"	BOLT DIA. (mm) "B"	ASTM 4.6	ASTM 8.8	ASTM 9.8	ASTM 10.9
8	5	1.8 (2.4)		5.1 (6.9)	6.5 (8.8)
10	6	3 (4)		8.7 (12)	11.1 (15)
13	8	7.3 (10)		21.1 (29)	27 (37)
16	10	14.5 (20)		42 (57)	53 (72)
18	12	25 (34)	74 (100)	73 (99)	93 (126)
21	14	40 (54)	118 (160)	116 (157)	148 (201)
24	16	62 (84)	167 (226)	181 (245)	230 (312)
30	20	122 (165)	325 (440)		449 (608)
33	22		443 (600)		611 (828)
36	24	211 (286)	563 (763)		778 (1054)
41	27		821 (1112)		1138 (1542)
46	30	418 (566)	1119 (1516)		1547 (2096)

*Use 75% of the specified torque value for plated fasteners. Use 85% of the specified torque values for lubricated fasteners.

Troubleshooting

2017 (v1.0)

Collection System Performance

Problem	Possible Cause	Corrective Action
Abnormal Vibration	<ul style="list-style-type: none"> • Cutting blades are bent or unbalanced • Loose blower pulley or pulley assembly • Impeller blade out of balance 	<ul style="list-style-type: none"> • Install new cutting blade • Tighten the pulley • Contact dealer to replace
Reduced collection system performance	<ul style="list-style-type: none"> • Low engine speed • Plugged screen • Loose belt • Full collection bags 	<ul style="list-style-type: none"> • Always operate collection system at full throttle • Remove debris, leaves, or grass clippings from the screen • Replace/tighten belt • Empty the collection bags
Blower and hoses plugging too frequently	<ul style="list-style-type: none"> • Collection bags are too full • Low engine speed • Grass is too wet • Grass is too long • Ground speed is too fast • Worn belt • Loose belt 	<ul style="list-style-type: none"> • Dump more frequently • Always operate collection system at full throttle • Cut grass when it is dry • Cut the grass several times • Drive slower at full throttle • Replace belt • Adjust the pulley and tighten belts
Debris blowout	<ul style="list-style-type: none"> • Collection bags are too full • Plug/clog in the collection system • Ground speed is too fast 	<ul style="list-style-type: none"> • Dump more frequently • Clean the collection system • Drive more slowly at full throttle
Impeller doesn't rotate freely	<ul style="list-style-type: none"> • Plug in the blower housing • Worn impeller blade • Shaft bearings bad/failing 	<ul style="list-style-type: none"> • Clean the blower housing • Contact dealer to replace • Contact dealer to replace

Notes



New PECO, Inc.
10 Walden Dr | Arden, North Carolina 28704
Phone: 1-800-438-5823 | 828-684-1234
Fax: 828-684-0858
Email: peco@lawnvac.com
Website: www.lawnvac.com