



Unit Model #: 37131509

Mower: Scag

Owner's Manual: Q0437

Mower Type: Freedom Z

Engine Type: Kawasaki FS730V

Deck Size: 61" Commercial

Vac Type: 15 Cu. Ft. Pro 3 Bagger

Deck Type:

Drive Type: Briggs & Stratton 6.5HP Vanguard

Revision #: 3 - Fit Year Updated - 08/20/2018

Fits Year(s): 2010-2018

A1852 Vac Kit

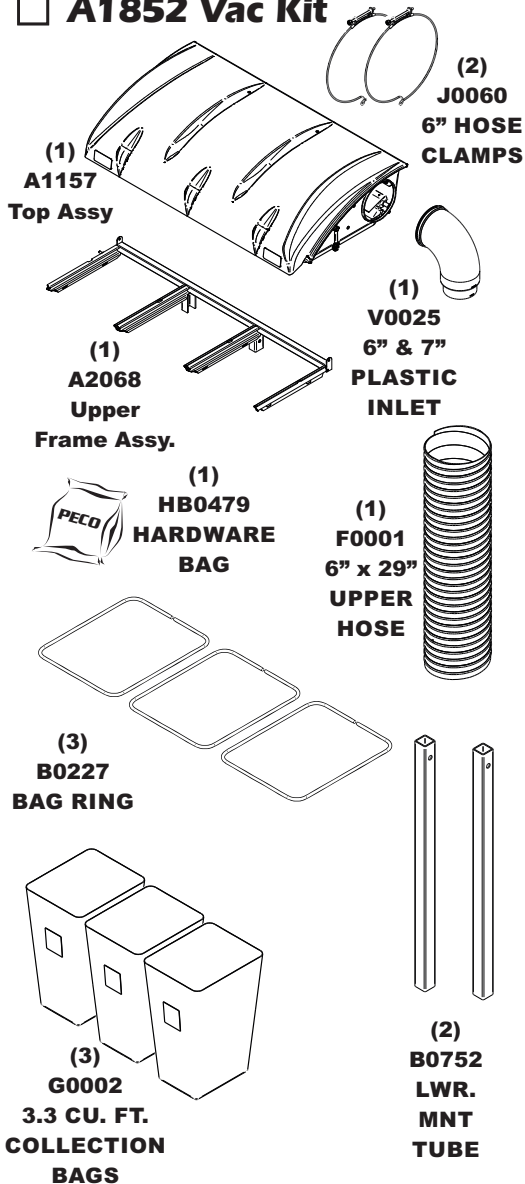

A1155 61" BAFFLE KIT

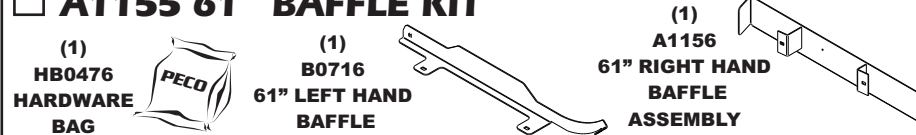

A1856 Mount Kit

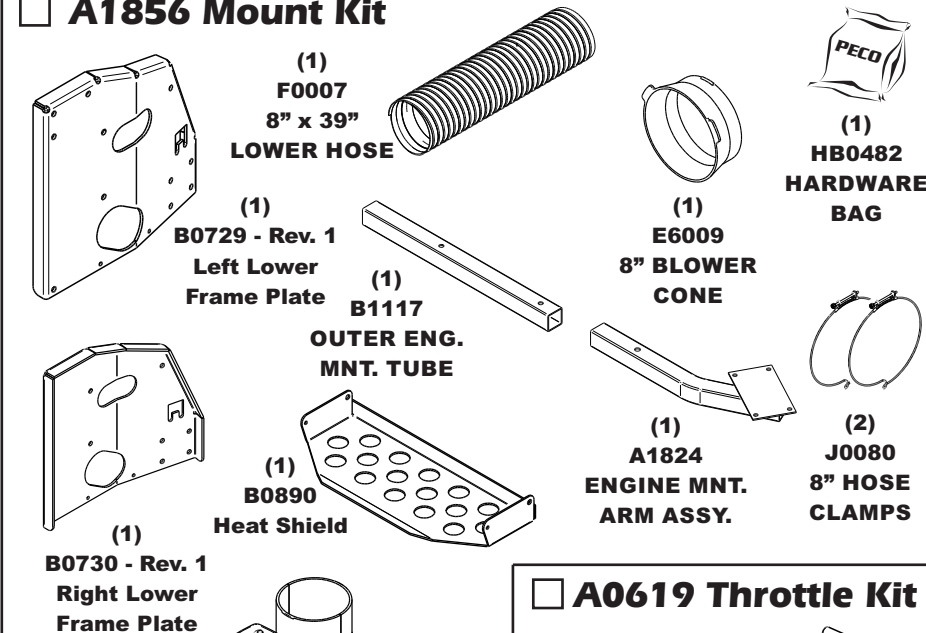

A0619 Throttle Kit

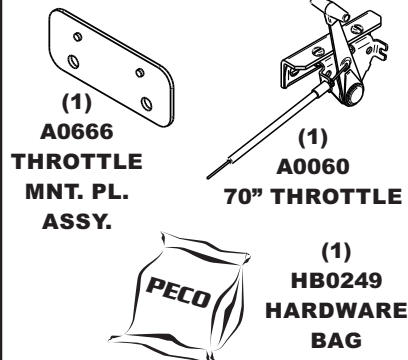

A1857 Boot Kit

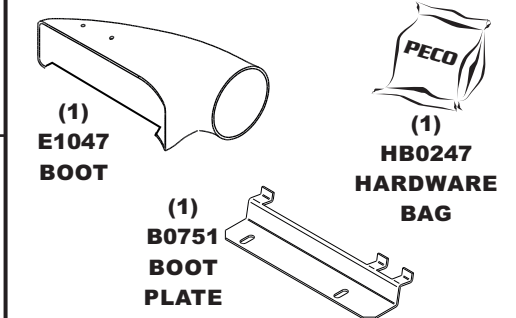

A2121 Dual Weight Kit / Single Caster

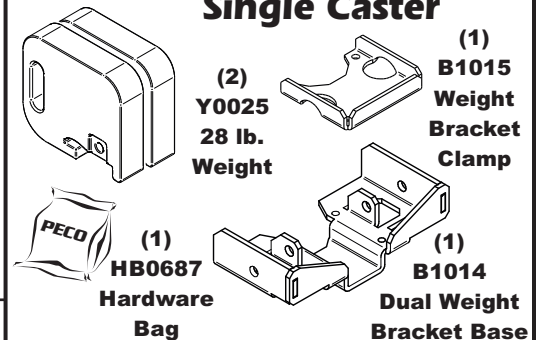

A2121 Dual Weight Kit / Single Caster

