



Unit Model #: 37131508

Mower: Scag

Owner's Manual: Q0437

Mower Type: Freedom Z

Engine Type: Kawasaki FS730V

Deck Size: 61" Commercial

Vac Type: 15 Cu. Ft. Pro 3 Bagger

Deck Type:

Drive Type: Briggs & Stratton 900 Series

Revision #: 2 - MY & Weight Kit Update - 1/23/2018

Fits Year(s): 2010-Newer

A1852 Vac Kit

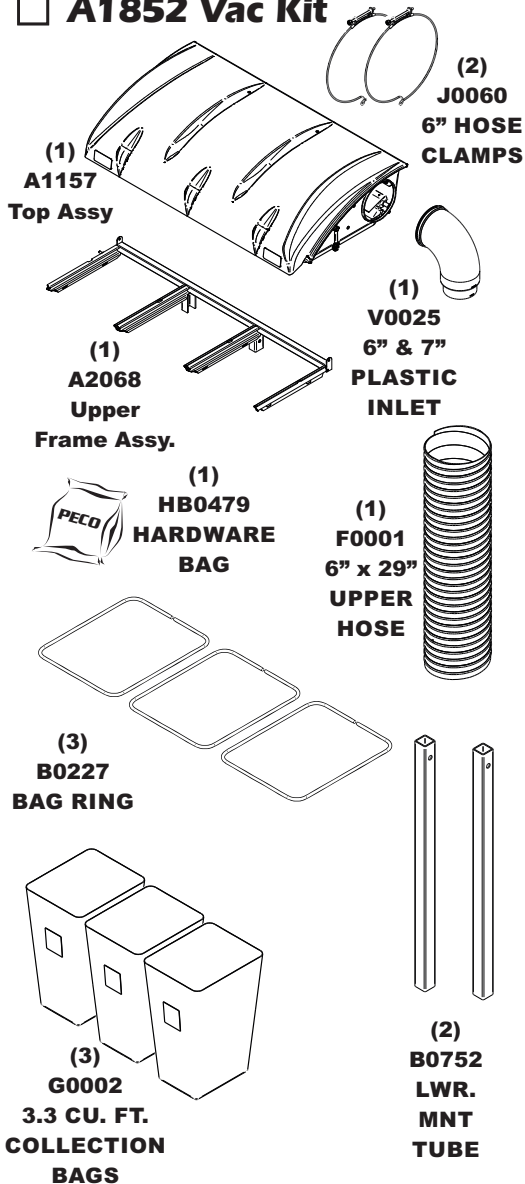

A1155 61" BAFFLE KIT

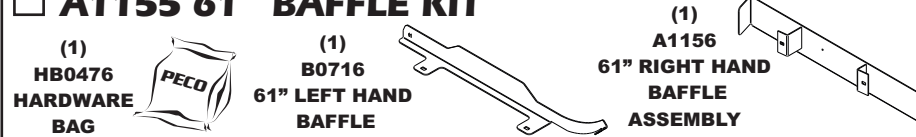

A1855 Mount Kit

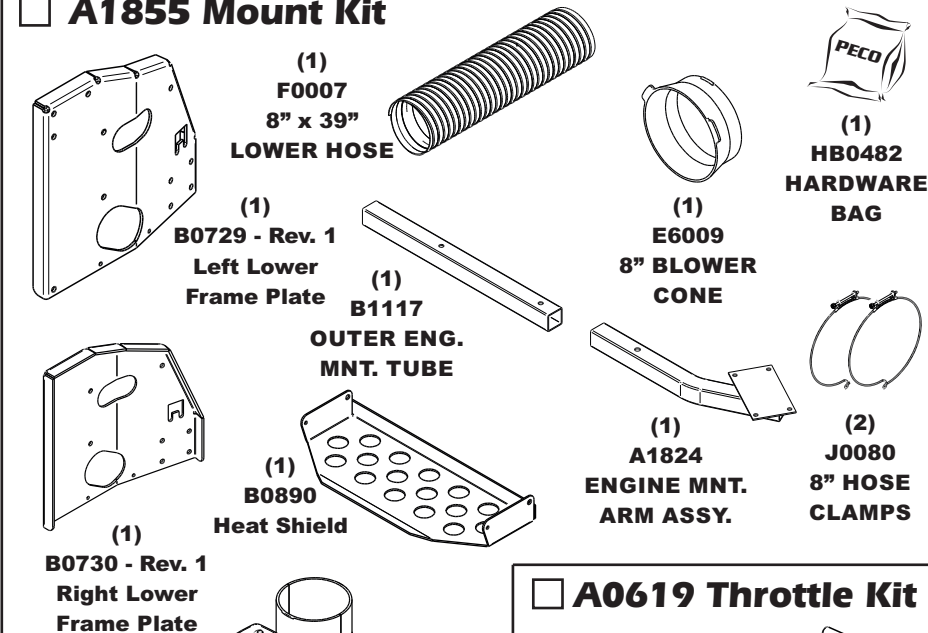

A0619 Throttle Kit

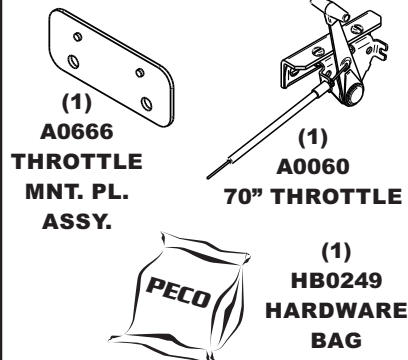

A1857 Boot Kit

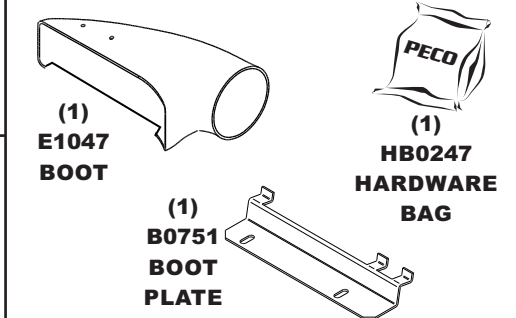

A2121 Dual Weight Kit / Single Caster

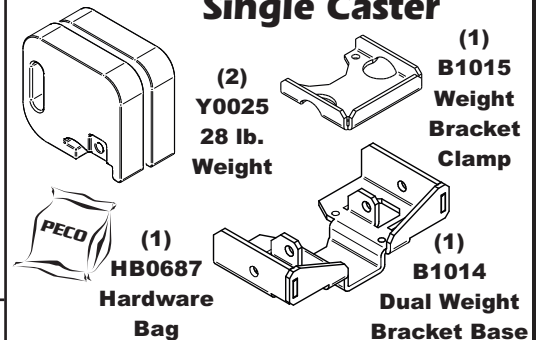

A2121 Dual Weight Kit / Single Caster

