

# MODEL#: 22131540

MOWER NAME: TORO G3, 3000, 5000 & 6000 SERIES

MODELS: 74952, 53, 54, 01, 03, 15, 30, 22, 23, 25, 26, 36

DECK: 48", 52" & 60"

VAC NAME: 15 CUBIC FOOT PRO BAGGER

ENG: BRIGGS & STRATTON 6.5 VANGUARD

MANUAL: Q0385



FOR YEAR: 2008-2013

REVISED: 7/15/13

## A1706 UNIT ASSEMBLY

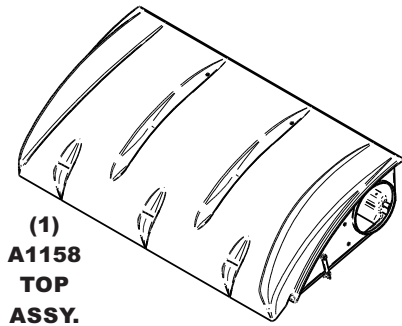

(1)  
A1158  
TOP  
ASSY.

(1)  
V0025  
6" & 7"  
PLASTIC  
INLET



(1)  
8" x 35"  
LOWER  
HOSE



(1)  
6" x 30"  
UPPER  
HOSE

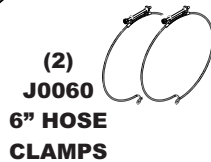

(2)  
J0060  
6" HOSE  
CLAMPS



(2)  
J0060  
6" HOSE  
CLAMPS



(1)  
E6009  
8" BLOWER  
CONE

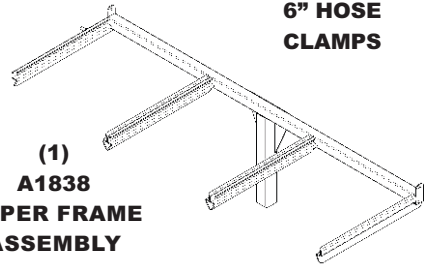

(1)  
A1838  
UPPER FRAME  
ASSEMBLY

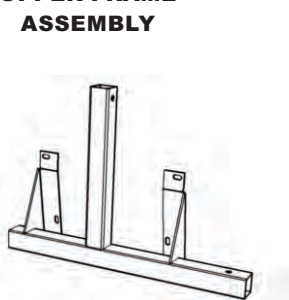

(1)  
A0605  
OUTER ENGINE  
MNT. TUBE ASSY.



(3)  
G0003  
4 CU. FT.  
COLLECTION  
BAGS



(1)  
C0061  
EXHAUST  
DEFLECTOR



(1)  
B0302  
LWR. MNT.  
CLAMP BRKT.

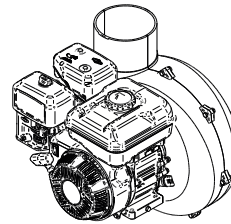

(1)  
A639  
ENGINE/  
BLOWER/  
BLADE ASSY.



(1)  
A0274  
ENGINE MOUNT  
ARM ASSY.



(1)  
HB0374  
HARDWARE  
BAG

(1) B0529 LEFT  
LOWER MAIN  
FRAME LEG

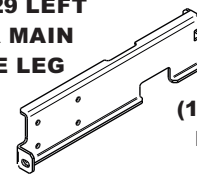

(1) B0528 RIGHT  
LOWER MAIN  
FRAME LEG

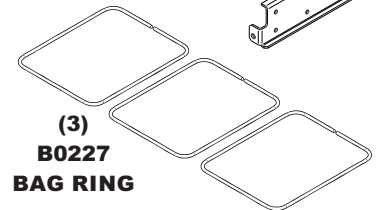
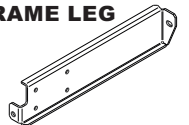

(3)  
B0227  
BAG RING

## A0619 THROTTLE KIT

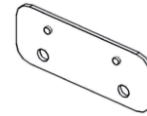

(1)  
A0666  
THROTTLE  
MNT. PL.  
ASSY.



(1)  
A0060  
70" THROTTLE  
KIT  
(5.5 & 6.5HP)



(1)  
HB0249  
HARDWARE  
BAG

## A0665 - WEIGHT KIT

(2)  
B0026  
WEIGHT  
BRACKETS

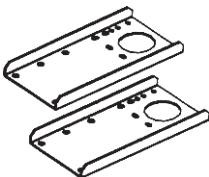

(1)  
HB0370  
HARDWARE  
BAG



(1)  
B2220  
WEIGHT

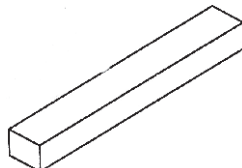

## A0640 - 60" BOOT KIT

(1)  
HB0207  
HARDWARE  
BAG



(1)  
B0537  
BOOT PLATE

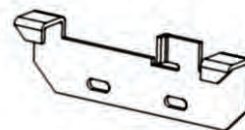

(1)  
E1039  
BOOT

