



Unit Model #: 37120906

Mower: Scag

Owner's Manual: Q0531

Mower Type: Freedom Z

Engine Type: KW FS691V-AS13

Deck Size: 52"

Vac Type: 9 Cu. Ft. Pro 2+ Bagger

Deck Type:

Drive Type: PTO-C Drive

Revision #: 3 - MY & Weight Kit Update - 1/23/2018

Fits Year(s): 2010-Newer

A1902 Vac Kit

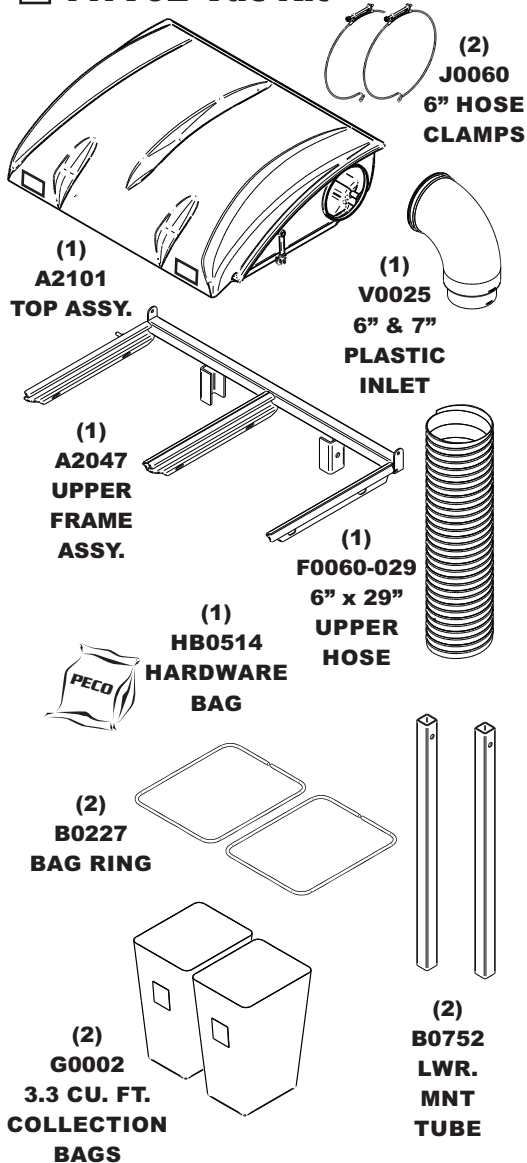

A1151 52" BAFFLE KIT



A2180 Mount Kit

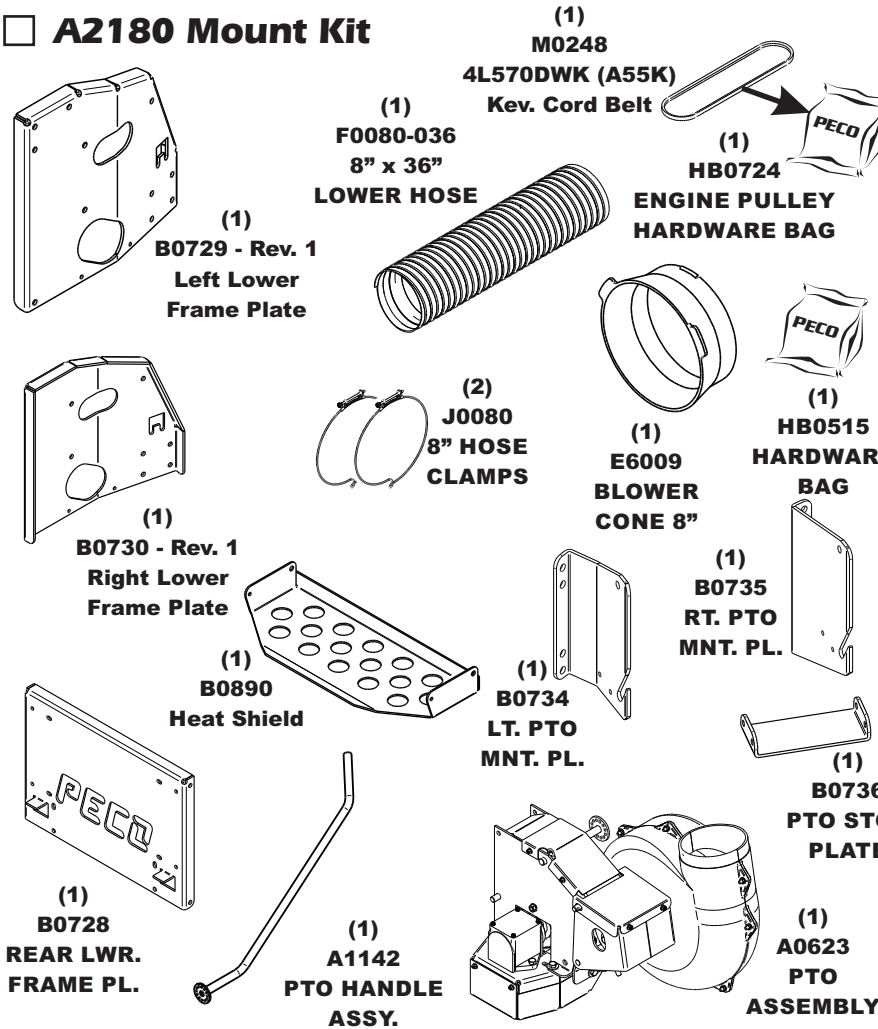

A2191 Boot Kit

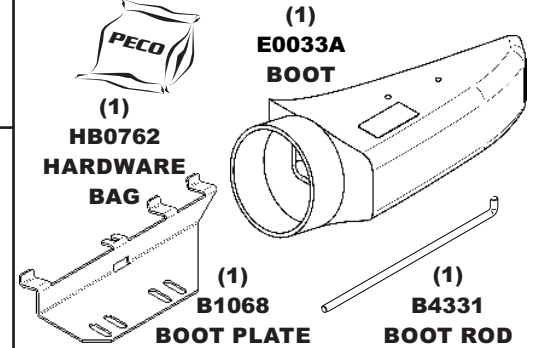

A2187 Dual Weight Kit

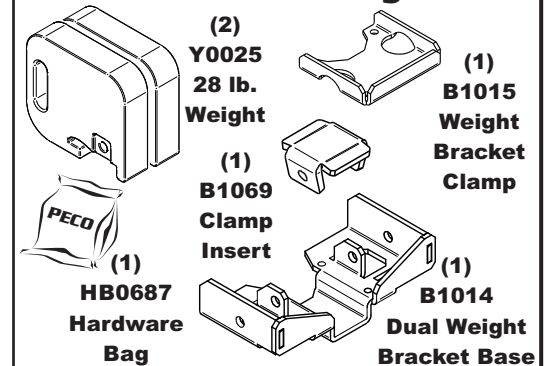

A2190 Weight Kit

