



PRO 2 BAGGER+ **GRASS COLLECTION** **SYSTEM**

PECO MODEL#:
37120901 & 37120902

SCAG FREEDOM Z



OPERATOR'S MANUAL

ASSEMBLY ● OPERATION ● MAINTENANCE

RESIDENTIAL BAGGING SYSTEM

TABLE OF CONTENTS

SECTION	PAGE	SECTION	PAGE
Safety	2	Impeller Blade Removal and Replacement	12
Safety Alert Symbols	3	Boot To Mower Deck Installation	13
Warranty	4	Length of Hose Adjustment	14
I INTRODUCTION AND DESCRIPTION	5	Upper Hose Installation	14
Introduction	5	Lower Hose To Blower Cone Installation	14
Description	5	Lower Hose To Boot Installation	14
II INSTALLATION FOR USE	5	Weight Kit Installation	15-16
Preparation Of Mower	5	Bag Assembly	17
Right & Left Lower Frame Plate Installation	6	Bag Assembly Installation	17
Rear Lower Frame Plate Installation	6	III OPERATING INSTRUCTIONS	18
Heat Guard Installation	6	General Safety	18
Lower Mount Tube Installation	7	Operation & Tips On Mowing	18
Upper Frame Assembly Installation	7	Disengagement Of The PTO Assembly	18
Top Assy. To Upper Frame Assy. Installation	7	Unloading The Collection System	18
Hinge Kit Installation	8	IV MAINTENANCE	18
Exhaust Diverter Installation	8	Maintenance Checklist	18
PTO Mount Plate Component Installation	8-9	Lubrication	19
PTO Assembly Installation	9	V PARTS AND SERVICE	19
Belt Removal and Adjustment	10-11	Parts And Service Information	19
Blower Cone Installation	12	Exploded Views And Parts List	20-24
		Safety Decals	25
		Torque Specifications	26

SAFETY

1. Read the operator's manual carefully and familiarize yourself with the proper use of your attachment. Do not allow anyone who is not acquainted with the Safety Instructions to use your attachment.
2. Know the controls and how to stop them quickly. **READ THE OPERATOR'S MANUAL!**
3. Do not allow children to operate the machine. Do not allow adults to operate it without proper instruction.
4. Be especially watchful of children and pets entering into the area while operating.
5. Keep your eyes and mind on your machine while mowing or operating your attachment. Don't let others distract you.
6. Do not attempt to operate your machine when not in the driver's seat.
7. Always shut off blades and engine when emptying the container.
8. Stop machine, shut off deck attachment, set parking brake, shut off engine and remove ignition key before removing clogs, removing or replacing hose, boot, blower cone, or performing any maintenance.
9. Mow across the face of slopes (not more than 10 degrees); never up and down the face.
10. It is recommended that the container be emptied when half full while operating on slopes. Start mowing on slopes when the container is empty.
11. Inspect your lawn and remove any foreign objects before mowing. Never deliberately run the mower across any foreign object.
12. Wear hearing protection.
13. Wear eye protection to prevent debris from getting into your eyes.

SAFETY

WARNING! NEVER operate the mower unless the discharge guard and either the deflector assembly or the vacuum collector adapter are fastened securely in place.

WARNING! Do not work around the mower deck boot or the blower area until you are certain that the mower blades and the blower impeller have stopped rotating.

WARNING! To avoid serious injury, perform maintenance on the vacuum collector; **ONLY AFTER STOPPING THE MOWER'S ENGINE AND WAITING FOR ALL MOVING PARTS TO COME TO A COMPLETE STOP.** Set the parking brake. Always remove the ignition key before beginning maintenance.

WARNING! For your own personal safety, **ALWAYS mow ACROSS the face of slopes and NEVER UP and DOWN the face. NEVER attempt to mow excessively steep slopes, and use caution when turning on any slope.**

Safety Alert Symbol



This Safety Alert Symbol means: **“ATTENTION! BECOME ALERT! YOUR SAFETY IS INVOLVED!”**

This symbol is used to call attention to safety precautions that should be followed by the operator to avoid accidents. When you see this symbol, carefully read the message that follows and heed its advice. Failure to comply with safety precautions could result in death or serious bodily injury.

Safety Signs

The signal words **DANGER**, **WARNING**, and **CAUTION** are used on the equipment safety signs. These words are intended to alert the viewer to the existence and the degree of hazard seriousness.



White letters on **RED**

This signal word indicates a potentially hazardous situation which, if not avoided, will result in death or serious injury.



Black letters on **ORANGE**

This signal word indicates a potentially hazardous situation which, if not avoided, could result in death or serious injury.

It may also be used to alert against unsafe practices.



Black letters on **YELLOW**

This signal word indicates a potentially hazardous situation which, if not avoided, will result in minor or moderate injury.

It may also be used to alert against unsafe practices.

PECO LIMITED WARRANTY FOR NEW PRODUCTS

A. WHAT IS UNDER WARRANTY?

PECO extends the following warranties to the original purchaser of each new PECO consumer product subject to the following limitations.

- 1. PRODUCT WARRANTY:** Any part of any consumer product, which is defective in material or workmanship as delivered to the purchaser will be repaired or replaced, as PECO elects, without charge for parts or labor, if the defect appears within 12 months from the date of delivery of the product to the original purchaser. ALL DEFECTIVE PARTS MUST BE RETURNED TO PECO FOR INSPECTION TO DETERMINE VALIDITY OF WARRANTY CLAIMS. Freight and mailing will be borne by the customer.
- 2. PARTS REPLACED DURING WARRANTY:** Any new PECO part which is furnished in performance of this warranty and is defective in material or workmanship as delivered to the purchaser will be repaired or replaced, before the expiration of the original warranty period, whichever is later.
- 3. COMMERCIAL USE:** Products put to personal use around a single household or residence is considered 'Residential'; Products put to any business use (agricultural, commercial, or industrial) or used at multiple locations is considered 'Commercial.' Products designated as 'Commercial' are warrantied for 12 months from the date of delivery of the product to the original purchaser when used for in commercial applications. Products designated as 'Residential' are warrantied for 90 days from the date of delivery of the product to the original purchaser when in commercial applications.

B. SECURING WARRANTY ADJUSTMENTS

Call PECO for Return Authorization. Damaged or broken parts other than engines or batteries, must be returned to New PECO, Inc. at 10 Walden Drive, Arden, NC 28704 before any warranty adjustment can be authorized. At the time of requesting warranty adjustment, the purchaser must present evidence of the date of delivery of the product. The purchaser shall pay any charge for the product to and from Arden, NC.

C. ITEMS NOT COVERED BY PECO WARRANTY

Engines and batteries attached to PECO products are covered under a separate warranty by the respective manufacturer.

D. UNAPPROVED ALTERATION OR MODIFICATION

All obligations of New PECO, Inc. under this warranty shall be terminated if products are altered or modified in ways not approved by New PECO, Inc.

E. ACCIDENTS AND NORMAL MAINTENANCE

The warranty covers only defective material and workmanship. It does not cover depreciation or damage caused by normal wear, accident, improper use or abuse of products. The cost of normal maintenance and normal replacement of service items such as belts, cutting blades, hoses, etc., which are not defective shall be paid for by the purchaser.

F. NO REPRESENTATIONS ADDITIONAL WARRANTIES, DISCLAIMER

Neither New PECO, Inc. nor any company affiliated with it makes any warranties, representations or promises as to the quality of performance of its products other than those set forth herein. Except as described above, New PECO, Inc. makes no other warranties AND SPECIFICALLY DISCLAIMS ANY AND ALL IMPLIED WARRANTIES OF FITNESS AND MERCHANTABILITY.

G. PRODUCTS USED FOR RENTAL OR LEASE PURPOSES ARE WARRANTIED FOR 45 DAYS FROM DATE OF ORIGINAL SALE ONLY

H. REMEDIED EXCLUSIVE

The only remedies the purchaser has in connection with the breach or performance of any warranty on New PECO, Inc. consumer products are set forth above. In no event will PECO be liable for special incidental or consequential damages.

1. NO SERVICE CENTER WARRANTY

The selling Service Center makes no warranty on his own on any item warrantied by New PECO, Inc. unless he delivers to purchaser a separate written warranty certificate specifically warranting the item. The dealer has no authority to make any representation or promise on behalf of PECO or to modify the terms of this warranty in any way.

Section I INTRODUCTION & DESCRIPTION

Introduction

Your grass collection system has been designed to give you a low maintenance, simple, and effective way to collect the grass clippings from your mower. This manual is provided to give you the necessary instructions to properly mount and operate the collection system on your mower. Please read this manual thoroughly. Understand what each control is for and how to use it. Observe all safety decal precautions on the machine and noted throughout the manual.

NOTE: all references made to right, left, front, rear, top or bottom are as viewed from the normal operator's position on the mower.

Description

The grass collection system is designed for turf maintenance where there is a need to collect the grass clippings as the mower cuts the turf. It is also used for picking up leaves in pre-season and post-season clean-up. The blower, mounted on the right side of the unit, uses a belt and gearbox system from the engine PTO shaft. Drive train protection comes through belt slippage. The blower draws grass clippings from the discharge area of the cutting deck back to the (2) - 3.3 cubic foot collection bags P#(G0002) at the rear portion of the mower frame. The operator can engage the blower with a spring-lock engagement handle on the right side of the unit. Once the bags are full with clippings, they can be easily released for dumping.

Section II INSTALLATION FOR USE

Preparation Of Mower

Remove the rear bumper from the mower frame. There are (8) 3/8" hex bolts that secure the rear bumper to the mower frame. Save this hardware for use later in the installation. See Figure A.

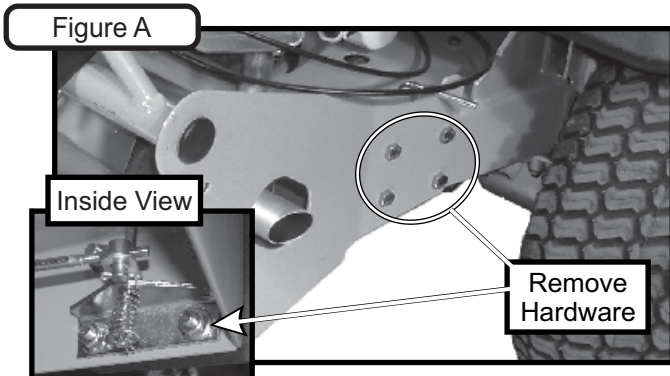

Next, check the exhaust direction, as if sitting in the Operator's Seat. If the exhaust is blowing to the Right-Hand Side, disassemble and reassemble the Diverter to point to the Left-Hand Side before continuing.

Remove the grass deflector and hardware from the mower deck as shown in Figure B.

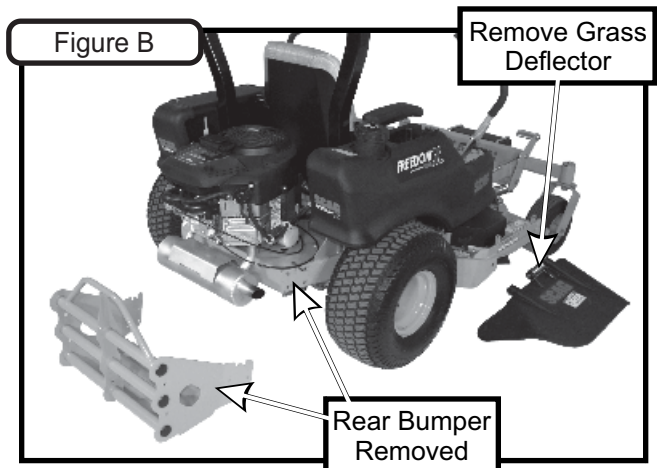

From the underside of the engine, remove the bolt and bushing from the electric clutch assembly. Use a bungee cord or similar device to hold the clutch in place while the hardware is removed.

Replace the hardware removed with the engine pulley bushing number 19 P#(S0211). Fasten the engine pulley to the electric clutch assembly using (1) Clamp Washer P#(K0278), (1) 7/16" hi-collar helical spring lock washer P#(K0140) and (1) 7/16"-20 x 3-1/4" HHCS P#(K0351). See Figure C for details.

For Kawasaki FS691V-AS13: Use engine pulley bushing number 29 P#(S0217). Fasten the engine pulley to the electric clutch assembly using (1) Clamp Washer P#(K0278), (1) 7/16" hi-collar helical spring lock washer P#(K0140) and (1) 7/16"-20 x 3-1/4" HHCS P#(K0351). See Figure C for details. The added pulley will power the collection system. Torque the bolt to 55 ft./lbs.

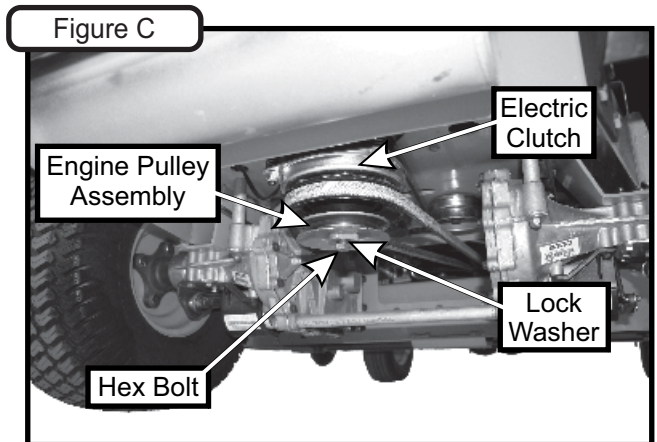

Right and Left Lower Frame Plate Installation

Fasten the right lower frame plate P#(B0730) to the rear frame of the mower using the (4) existing 3/8"-16 hex bolts and (4) 3/8"-16 nuts from the right rear bumper. Leave the hardware slightly loose until the heat guard has been installed. Refer to Figure A.

Figure A

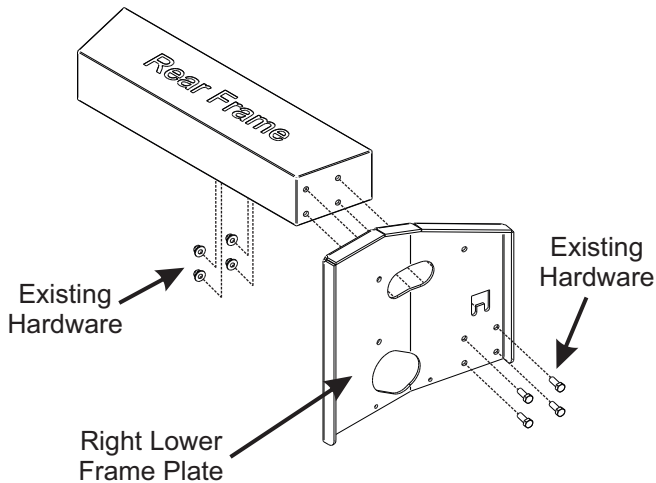

Fasten the left lower frame plate P#(B0729) to the rear frame of the mower using the (4) existing 3/8"-16 hex bolts and (4) 3/8"-16 nuts from the right rear bumper. Leave the hardware slightly loose until the heat guard has been installed. Refer to Figure B.

Figure B

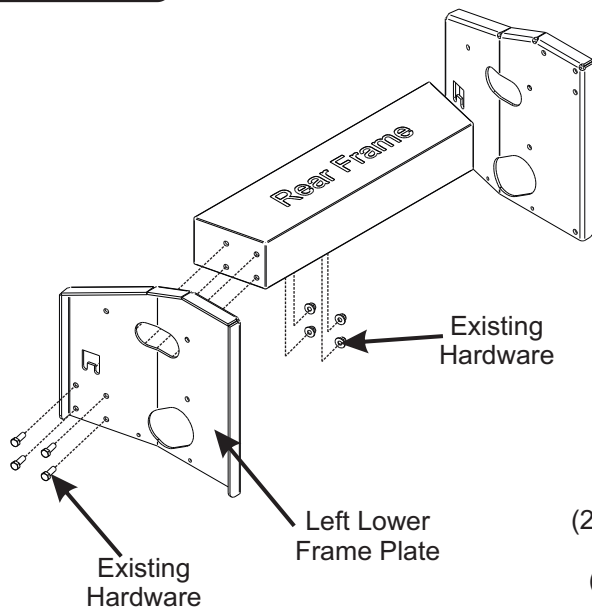

Rear Lower Frame Plate Installation

Fasten the top portion of the rear lower frame plate P#(B0728) to the left and right lower frame plate using (2) 3/8"-16 x 1" HHCS P#(K1191) and (2) 3/8"-16 nylon flange locknuts P#(K2038). Leave hardware slightly loose until the heat guard has been installed. Refer to Figure C.

Figure C

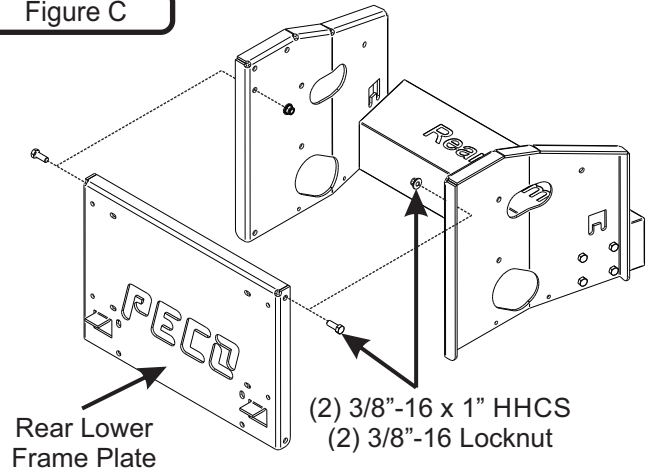

Heat Guard Installation

Secure front holes of heat shield P#(B0890) to left lower frame plate and right lower frame plate, using (2) 1/4"-20 x 3/4" HHCS P#(K1222), (2) 1/4"-20 nylon flange locknuts P#(K2014) and (4) 1/4" Flat Washers P#(K0037). Secure rear holes using (2) 3/8"-16 x 1" HHCS P#(K1191) and (2) 3/8"-16 nylon flange locknuts P#(K2038). Once the heat shield has been installed, tighten all frame plate hardware. Refer to D.

Figure D

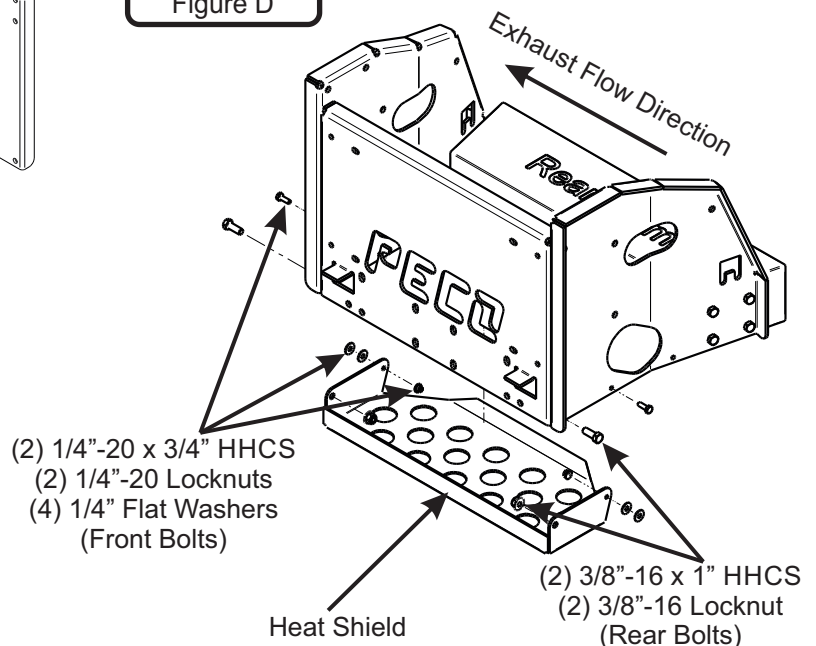

Lower Mount Tube Installation

Secure the (2) lower mount tubes P#(B0752) to the rear lower frame plate using (2) 5/16"-18 u-bolts P#(K1098) and (4) 5/16"-18 nylon flange locknuts P#(K2516) PER TUBE. Refer to Figure A.

Figure A

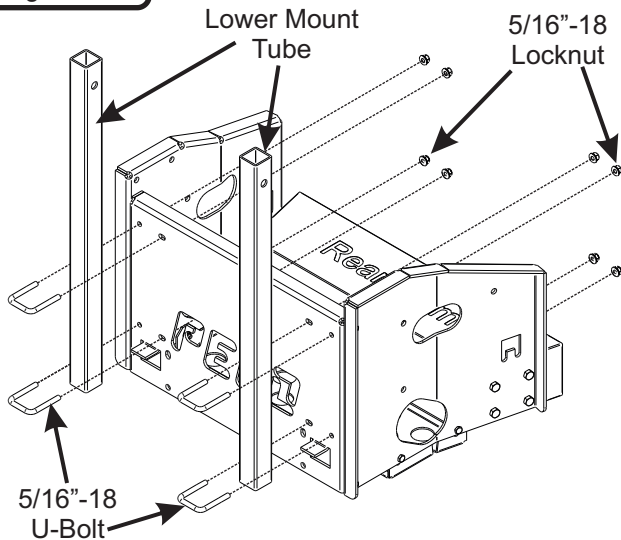

Upper Frame Assembly Installation

Position the upper frame assembly P#(A2047) above the lower mount tubes as shown in Figure B. Slide the upper frame assembly down onto the lower frame tubes and secure using (2) clevis pins P#(K0133) and (2) Rue Ring Cotter Pins P#(K1437).

Figure B

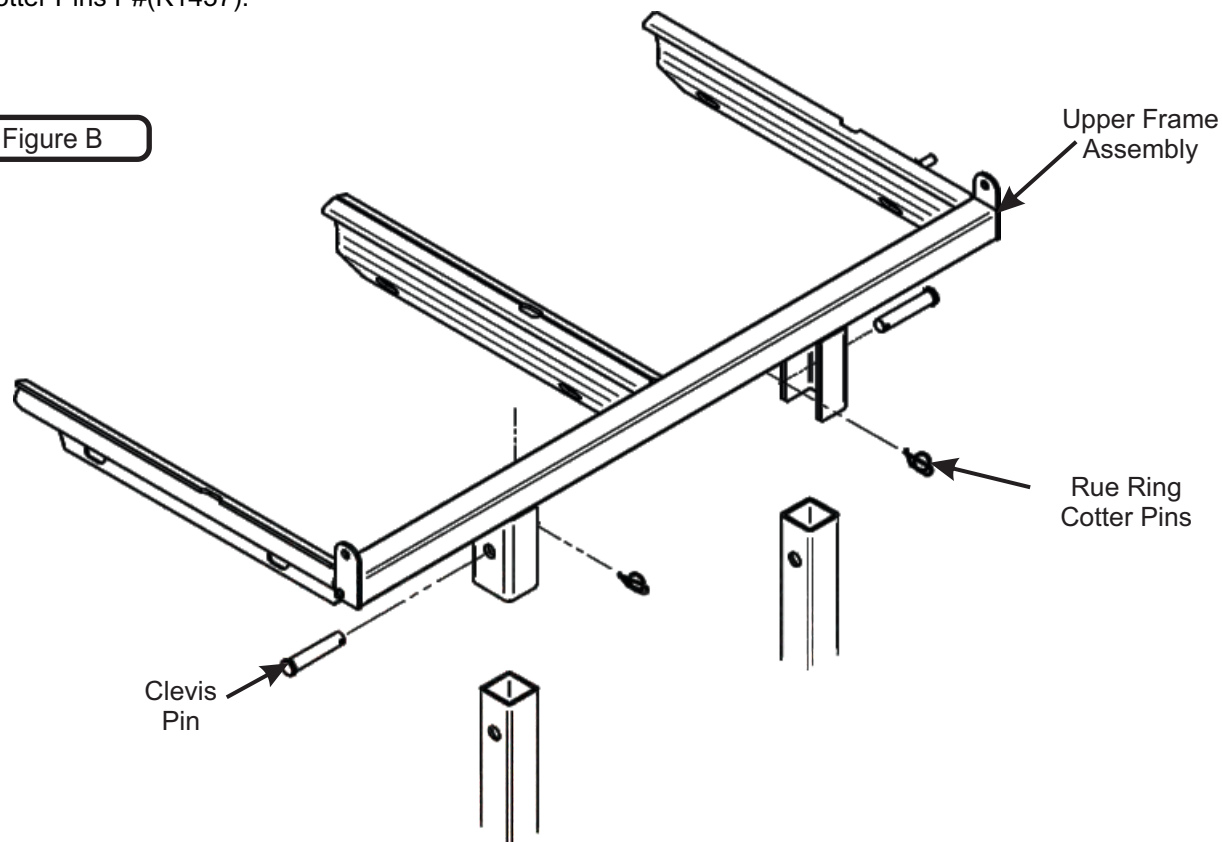

Top Assembly To Upper Frame Assembly Installation

Position the top assembly P#(A2101) above the upper frame assembly as shown in Figure C. Fasten the top assembly to the upper frame assembly using (2) 5/16"-18 x 2-1/2" HHCS P#(K0125), (2) 1/4" Flat Washer P#(K0037), and (2) 5/16"-18 nylon flange locknuts P#(K2516). Leave the locknuts slightly loose, to allow the top assembly to open and close easily. Refer to Figure C for hardware location.

Insert the Inlet P#(V0025) into the hole on the top assembly from the inside and then snap the inlet into place. The inlet should pivot freely about the hole.

Figure C

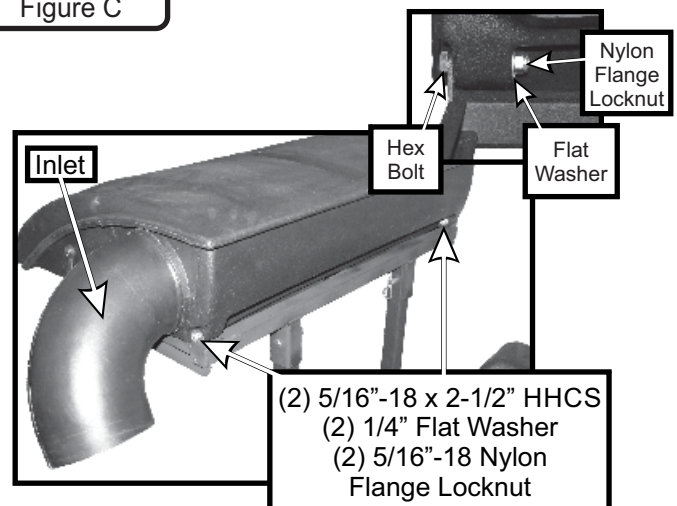

Hinge Kit Assembly Installation

Assemble the Hinge Kit using (1) Latch Plate P#(B0884), (1) 5/16"-18 x 1-1/4" HHCS P#(K1156), (1) 5/16"-18 Ny-Flange Lock Nut P#(K2516), (3) 5/16" Flat Washers P#(K0042), (1) Latch Spacer P#(S0006), (2) Extra Heavy 5/16" Fender Washers P#(K0505) and (1) 5/16"-18 Lock Nut P#(K0506). Leave the nuts loose enough to allow fluid movement of the top when opening and closing. When opened, the top should rest in the Latch Plate Slot.

Figure A

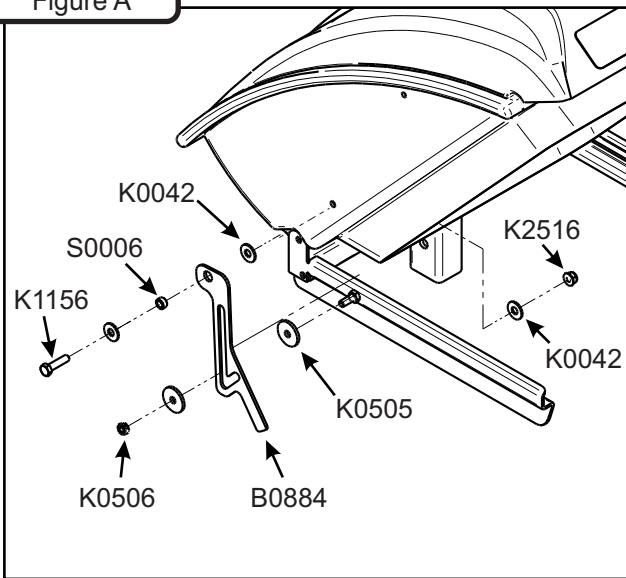

Exhaust Diverter Installation

Insert the exhaust deflector P#(J0251) onto the end of the muffler. Orientate the exhaust diverter to exhaust towards the rear of the mower, slightly downward to avoid burning the cloth bags or the grass. Secure the exhaust diverter with (1) exhaust clamp kit P#(X1046). Refer to Figure B.

Figure B

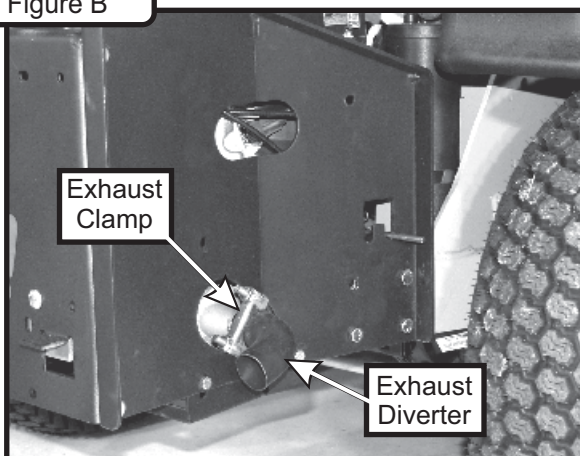

PTO Mount Plate Component Installation

Secure the left PTO mount plate P#(B0731) to the right lower frame plate using (2) 3/8"-16 x 1" HHCS P#(K1191) and (2) 3/8"-16 nylon flange locknuts P#(K2038). Leave the hardware slightly loose until the PTO stop plate has been installed. Refer to Figure C.

Figure C

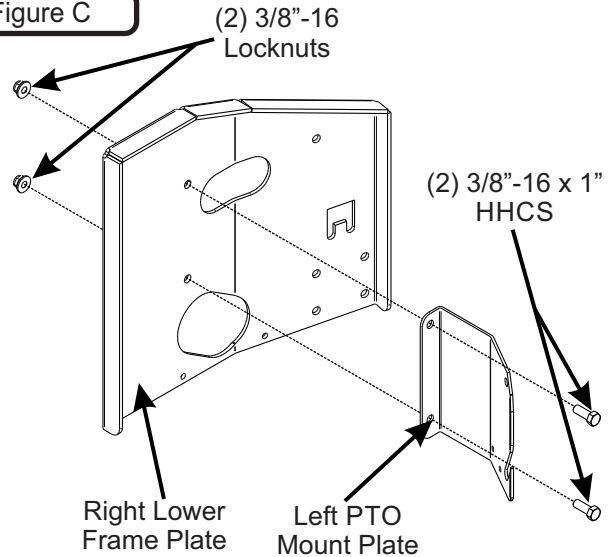

Secure the right PTO mount plate P#(B0732) to the right lower frame plate using (2) 3/8"-16 x 1" HHCS P#(K1191) and (2) 3/8"-16 nylon flange locknuts P#(K2038). Leave the hardware slightly loose until the PTO stop plate has been installed. Refer to Figure D.

Figure D

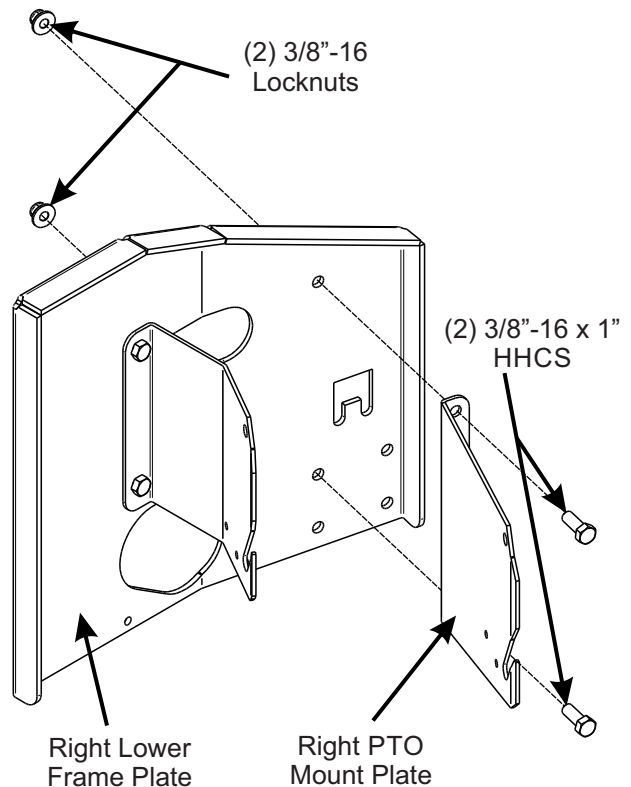

PTO Mount Plate Component Installation Continued...

Secure the PTO stop plate P#(B0733) to the left and right PTO mount plates using (4) 1/4"-20 x 3/4" HHCS P#(K1222) and (4) 1/4"-20 nylon flange locknuts P#(K2014). With the stop plate secured, tighten all PTO mount plate component hardware at this time. Refer to Figure E.

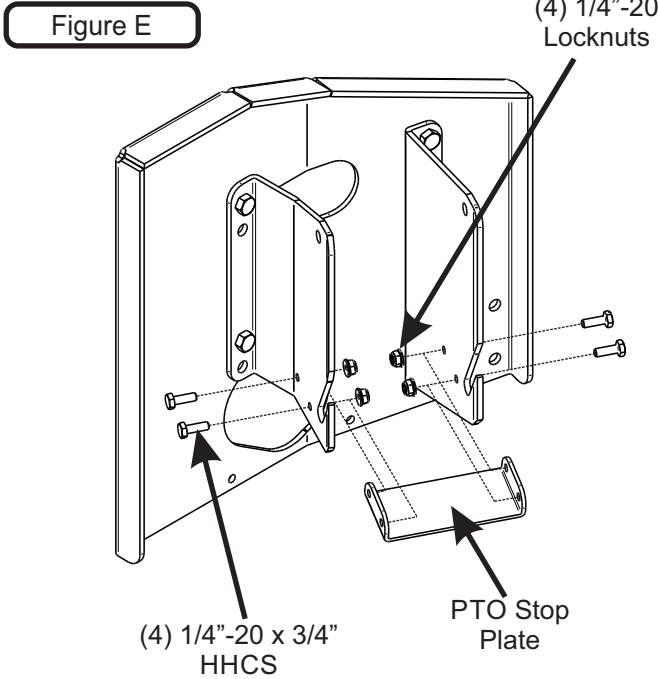
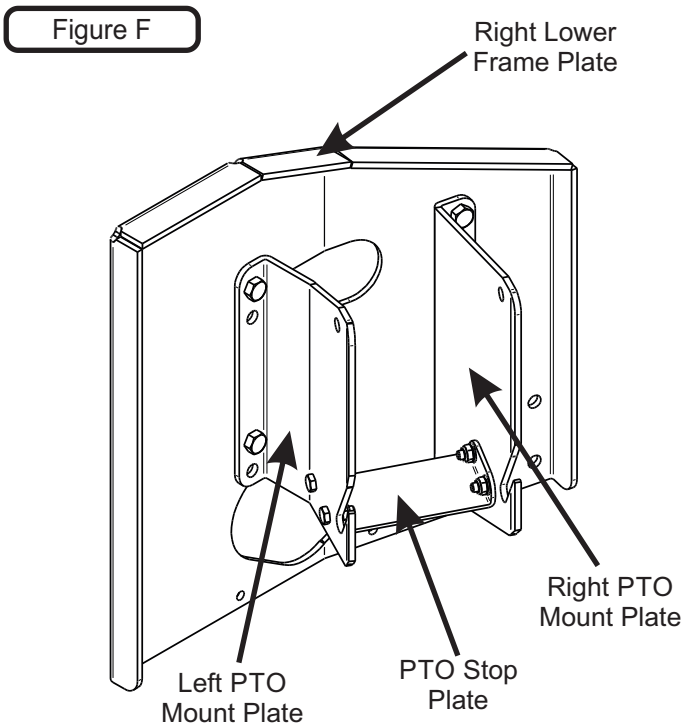
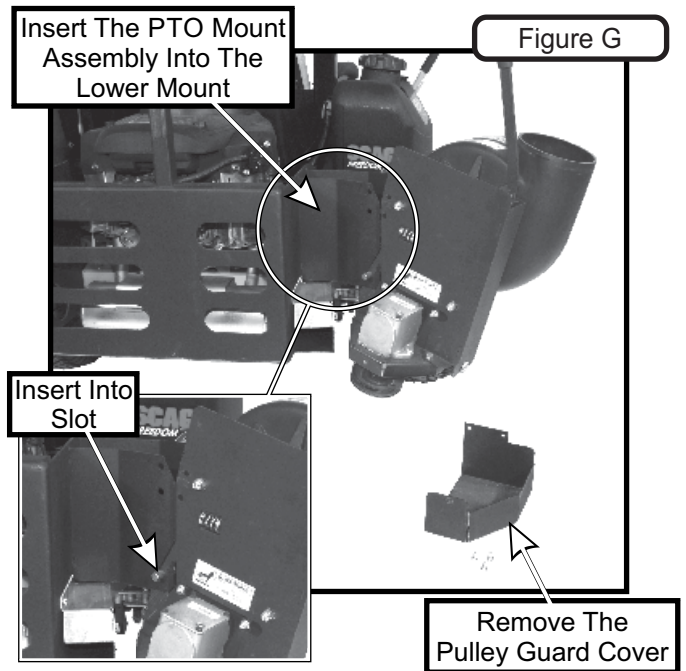

Figure F shows the complete PTO mount plate assembly as it should be assembled on your mower.



PTO Assembly Installation

Insert the PTO assembly P#(A1840) into the lower PTO mount assembly as shown in Figure G. Remove the pulley guard for preparation of the belt installation.



Belt Installation/Removal and Adjustment

Installation/Removal:

(Step 1) Loosen the (4) 5/16"-18 x 3/4" HHCS P#(K1153) that secure the gear box to the PTO assembly. There are (2) 5/16"-18 x 3/4" HHCS on the rear side of the PTO assembly where the gearbox is located (Figure A), and there are (2) 5-16"-18 x 3/4" HHCS on the front side of the PTO assembly underneath the blower housing. See Figure B.

(Step 2) Loosen the adjustment bolt (1) 3/8"-16 x 2" hex bolt P#(K0348) located on the side of the PTO assembly. See Figure B.

(Step 3) Slide the gearbox towards the mower until there is enough clearance for the kevlar belt A57K P#(M0256) to slide over both the engine and gearbox pulleys. See Figure C.

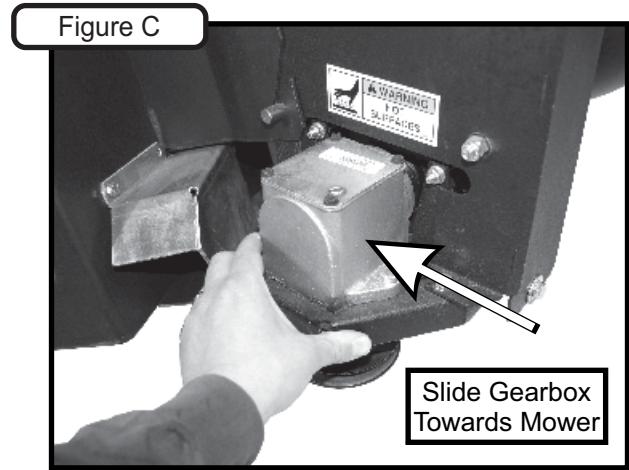
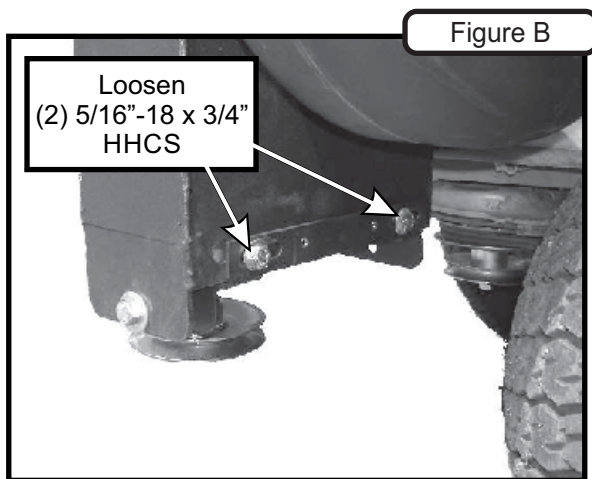
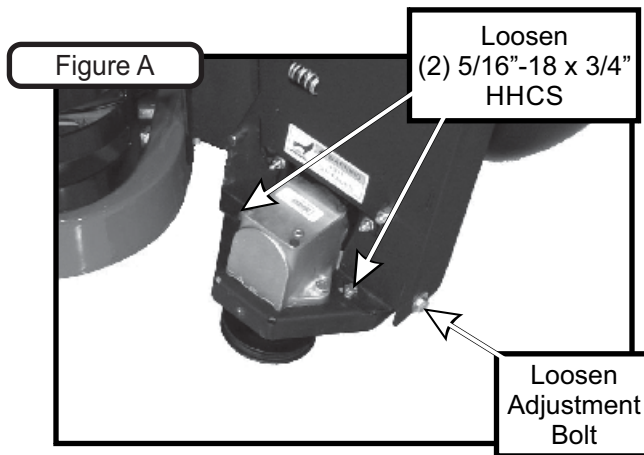

(Step 4) Wrap the kevlar belt around both pulleys.

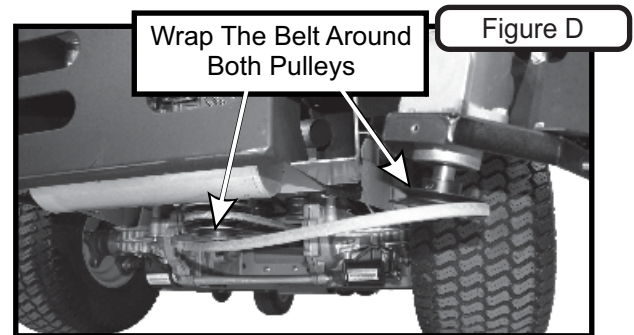

(Step 5) Secure the PTO assembly to the lower PTO mount assembly using (1) PTO assembly mount pin P#(B0274) and (1) hair pin clip P#(K0086). See Figure E.

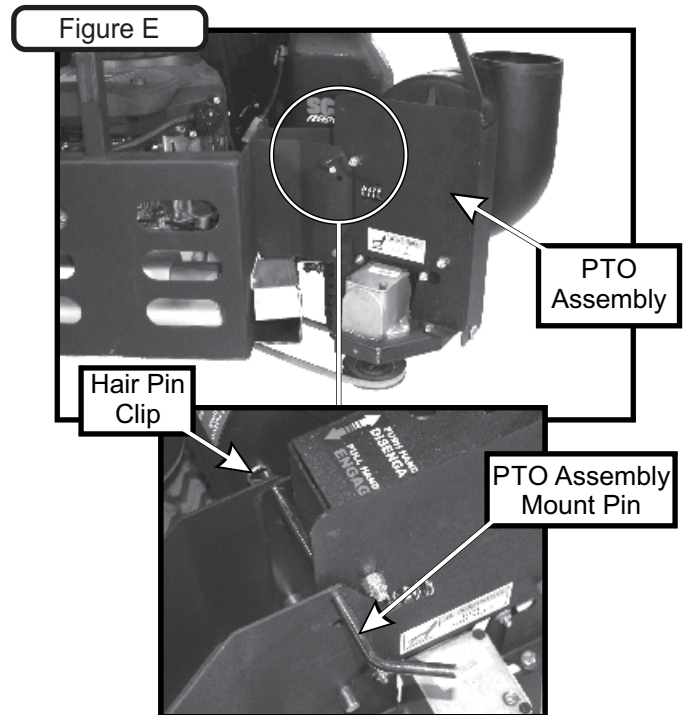

Belt Installation/Removal/Adjustment Cont.

Adjustment: To adjust the belt tension, turn the adjustment bolt clockwise until there is 1" of deflection, with 10-11lbs of pressure applied to the center of the belt. When the belt has the proper tension, tighten the (4) 5/16"-18 x 3/4" HHCS that secure the gear box to the PTO assembly. Replace the belt guard and (3) 1/4"-20 x 1/2" HHSTS. Refer to the Figures below.

Figure F

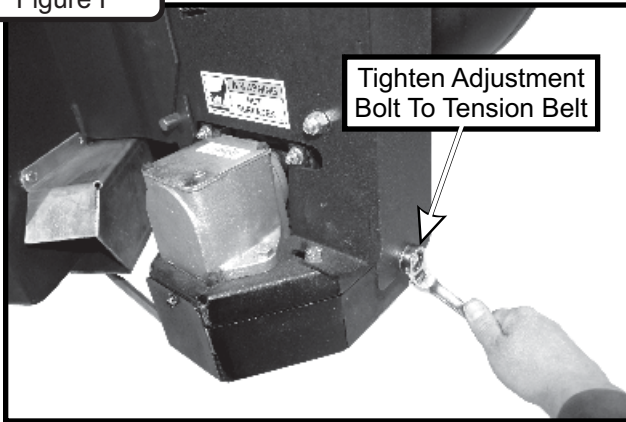

Figure G

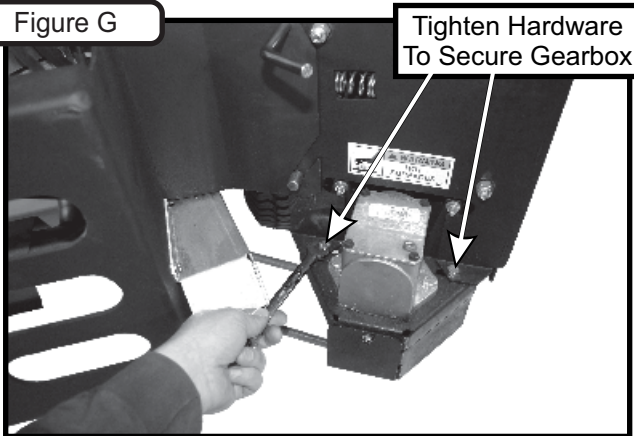
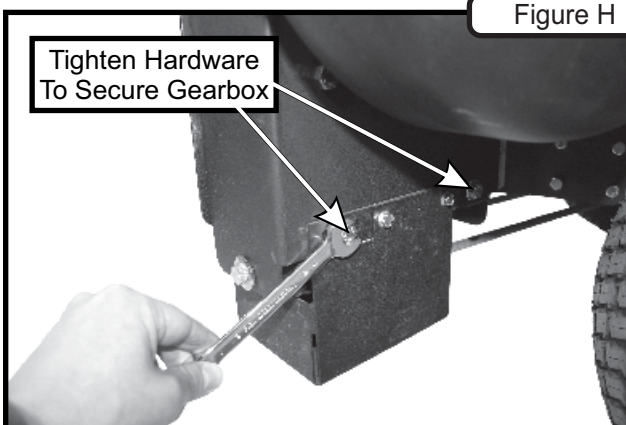
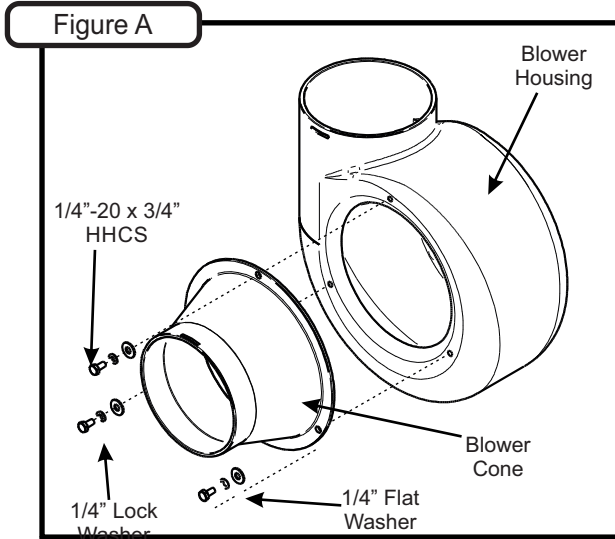

Figure H



Blower Cone Installation/Removal

Fasten the blower cone P#(V0016) to the blower housing located on the PTO assembly. Use (3) 1/4"-20 x 3/4" HHCS P#(K1222), (3) 1/4" lock washers P#(K0039), and (3) 1/4" flat washers P#(K0037) to secure the blower cone to the blower housing. Refer to Figure A for reference.



Impeller Blade Removal/Replacement

To Remove: To access the impeller blade, remove the blower cone P#(V0016) and blower cone hardware from the blower housing. Remove the 5/16"-24 x 7/8" left hand thread hex bolt P#(K1171) and washer P#(K1446). Insert (1) 1/2"-13 x 1" hex bolt into the threads on the impeller blade. Tighten the hex bolt until the impeller blade breaks free from the PTO shaft. Remove the impeller blade assembly P#(A1839) from the PTO shaft. Remove the key P#(J0254) from the PTO shaft.

To Replace: Insert the key P#(J0254) into the keyway slot on the PTO shaft. Align the keyway slot on the bushing of the impeller blade assembly with the key on the PTO shaft and insert the impeller blade onto the PTO shaft. Secure the impeller blade with (1) 5/16"-24 x 7/8" left hand thread hex bolt P#(K1171) and (1) washer P#(K1446). Replace the blower cone P#(V0016) and blower cone hardware. Refer to Figure B for reference.

Figure B

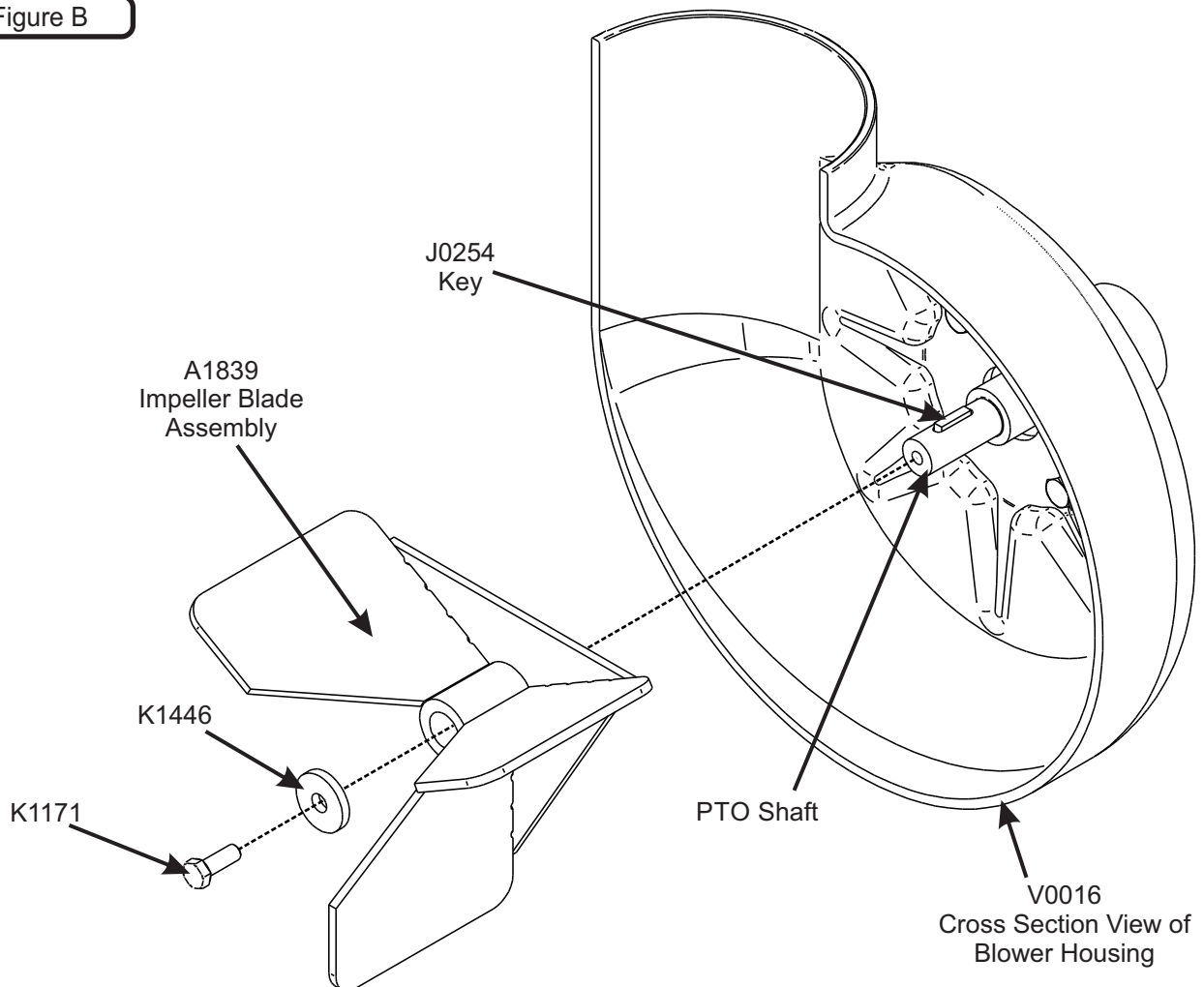

Boot To Mower Deck Installation

Fasten the boot plate P#(B0577) to the boot P#(V0027) for 48" decks or P#(V0028) for 52" decks, using (1) boot plate fastener P#(B0919), (3) 5/16"-18 x 1" carriage bolts P#(K1144), (3) Spacer Bushings P#(S3143), and (3) 5/16"-18 nylon flange locknuts P#(K2516). Insert the boot plate fastener and carriage bolts from inside the boot, so the threads are on the outside. This will prevent grass clippings from collecting on the threads. Refer to Figure A.

Secure the boot plate to the mower deck using (1) boot rod P#(B4331) and (1) hair pin clip P#(K0099). See Figure B.

Figure A

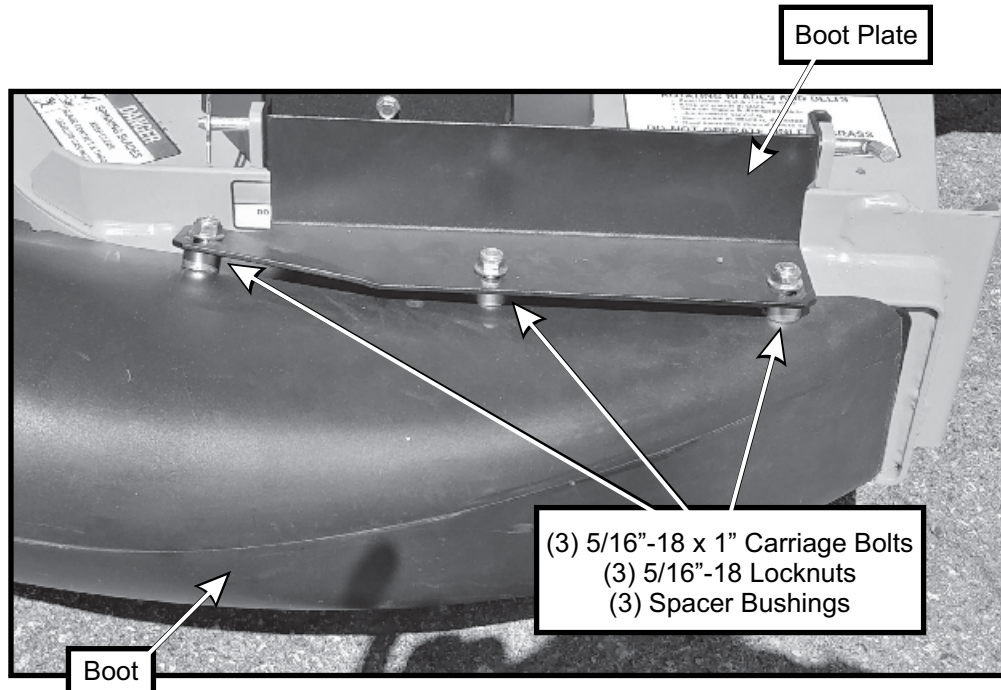
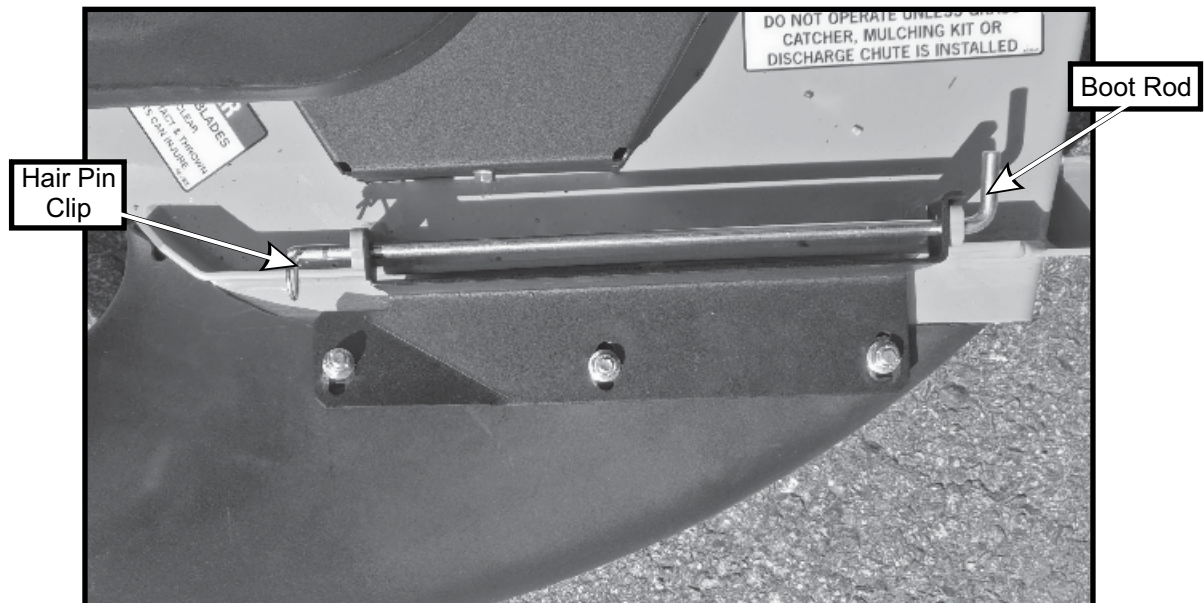

Figure B



Length Of Hose Adjustment

The hoses must be cut to fit your machine. Do not cut the hoses until you have tried to fit them on your machine. Remember that the hoses have to be long enough to adjust for the blower assembly's movement as well as allow for enough clamping surface between the inlet, blower assembly and the deck boot.

Upper Hose Installation

Slide a hose clamp P#(J0060) over both ends of the upper hose. Then slide one end of the upper hose onto the inlet. Make sure there is about a two-inch overlap between the hose end and the container inlet. Proceed to slide the opposite end of the upper hose onto the outlet of the blower assembly. See Figure A for details. Tighten the hose clamps.

Lower Hose To Blower Cone Installation

Slide a hose clamp P#(J0060) over both ends of the 6" lower hose. Then proceed to slide the lower hose onto the blower cone. Tighten the hose clamp. See Figure A for details.

Lower Hose To Boot Installation

Take the unattached end of the lower hose and slide it over the circular end of the boot. Use the hose clamp P#(J0060) to secure the hose to the boot.

NOTE: Before tightening the hose clamp, rotate the lower hose counter clockwise (see Figure 2-17) approximately 1" and then tighten the clamp. This will hold the bottom edge of the boot tight to the mower deck.

Figure A

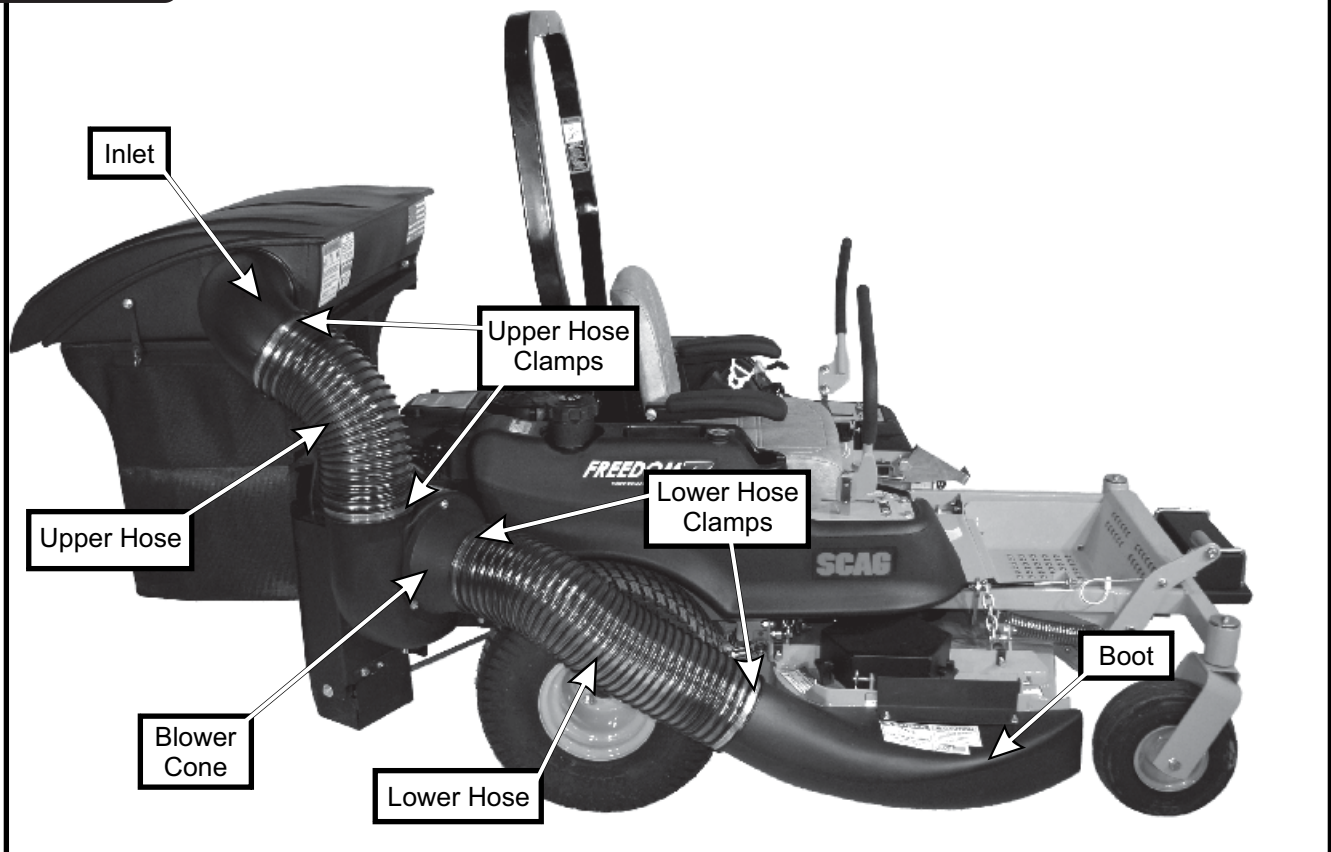

Dual Weight Kit Installation / Single Caster

To Install Weight Bracket

Step 1 - Position (#2) Base Under Caster Tubing w/
Opening Towards Caster Fork.

Step 2 - Place (#5) Clamp Insert On Top Of Caster
Tubing Above (#2) Base

Step 3 - Position (#3) Clamp On Top Of (#5) Clamp
Insert w/ Opening Towards Caster Fork.

Step 4 - Align (4) Holes In (#3) Clamp To Holes In (#2)
Base

Step 5 - Loosly Fasten (#3) Clamp To (#2) Base Using
(4) (#4.1) 5/16"-18 x 3" Bolts & (4) (#4.2) 5/16"-18 Ny-
Flange Lock Nuts.

Step 6 - Position (#2 & #3) Assembly Along Caster
Tubing To Prevent Interference From Caster Forks Or
Any Other Objects. Tighten Fasteners In An ' Pattern
Until Assembly Is Firmly Clamped To Caster Tubing. Do
Not Overtighten Resulting In Bending (#3) Clamp.

Step 7 - Insert (#1) Weight Into (#2) Base & Align Hole In
Weight w/ Holes In (#2) Base.

Step 8 - Fasten (#1) Weight To (#2) Base Using (1)
(#4.3) Clevis Pin & (1) (#4.4) Hair Pin Clip. Repeat For
Additional Weights.

Refer to Figure A.

Figure A

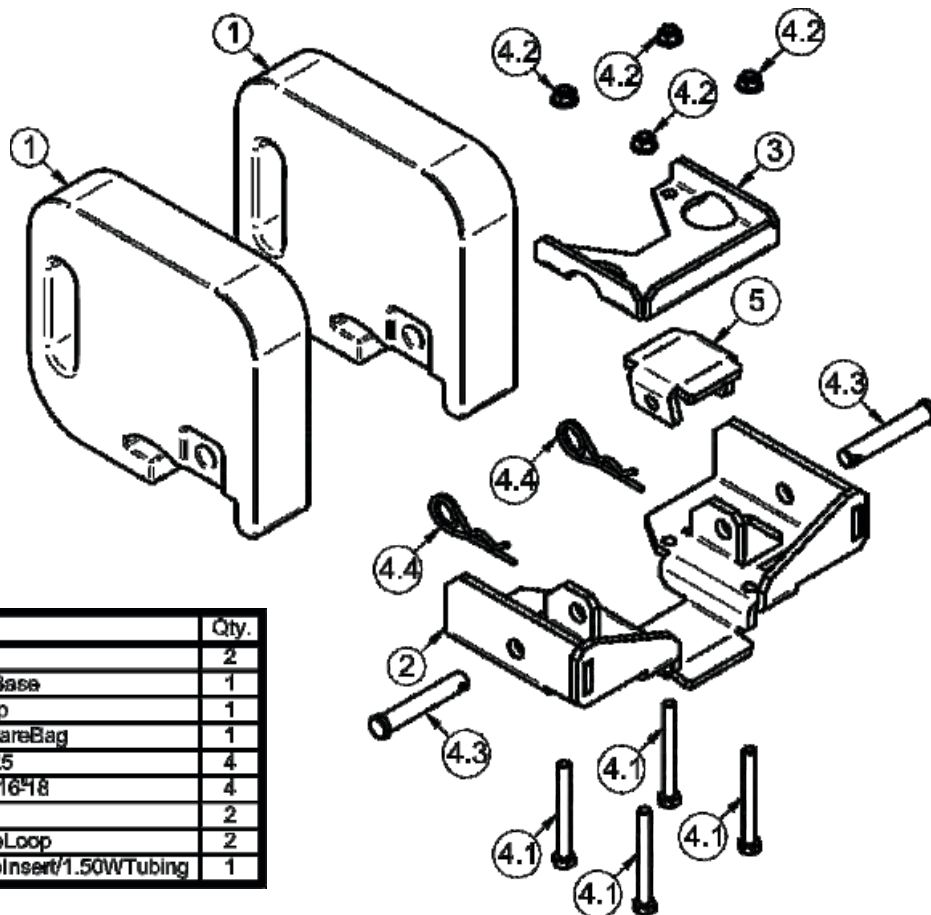

Item#	Part#	Desc.	Qty.
1	Y0025	28lb SuitcaseWeight	2
2	B1014	DualWeightBracket/Base	1
3	B1015	WeightBracket/Clamp	1
4	HB0687	DualWeightKitHardwareBag	1
4.1	K1472	HHCS5/16-18x3 GR5	4
4.2	K2516	Ny-FlangeLockNut5/16-18	4
4.3	K1473	ClevisPin1/2x3"	2
4.4	K1478	HairPinCotter/DoubleLoop	2
5	B1069	WeightBracketClampInsert/1.50WTubing	1



Weight Kit Installation / Left Caster

To Install Weight Bracket

Step 1 - Position (#2) Base Under Caster Tubing w/ Opening Towards Caster Fork.

Step 2 - Place (#5) Clamp Insert On Top Of Caster Tubing Above (#2) Base

Step 3 - Position (#3) Clamp On Top Of (#5) Clamp Insert w/ Opening Towards Caster Fork.

Step 4 - Align (4) Holes In (#3) Clamp To Holes In (#2) Base

Step 5 - Loosly Fasten (#3) Clamp To (#2) Base Using (4) (#4.1) 5/16"-18 x 3" Bolts & (4) (#4.2) 5/16"-18 Ny-Flange Lock Nuts.

Step 6 - Position (#2 & #3) Assembly Along Caster Tubing To Prevent Interference From Caster Forks Or Any Other Objects. Tighten Fasteners In An ' Pattern Until Assembly Is Firmly Clamped To Caster Tubing. Do Not Overtighten Resulting In Bending (#3) Clamp.

Step 7 - Insert (#1) Weight Into (#2) Base & Align Hole In Weight w/ Holes In (#2) Base.

Step 8 - Fasten (#1) Weight To (#2) Base Using (1) (#4.3) Clevis Pin & (1) (#4.4) Hair Pin Clip.

Refer to Figure A.

Figure A

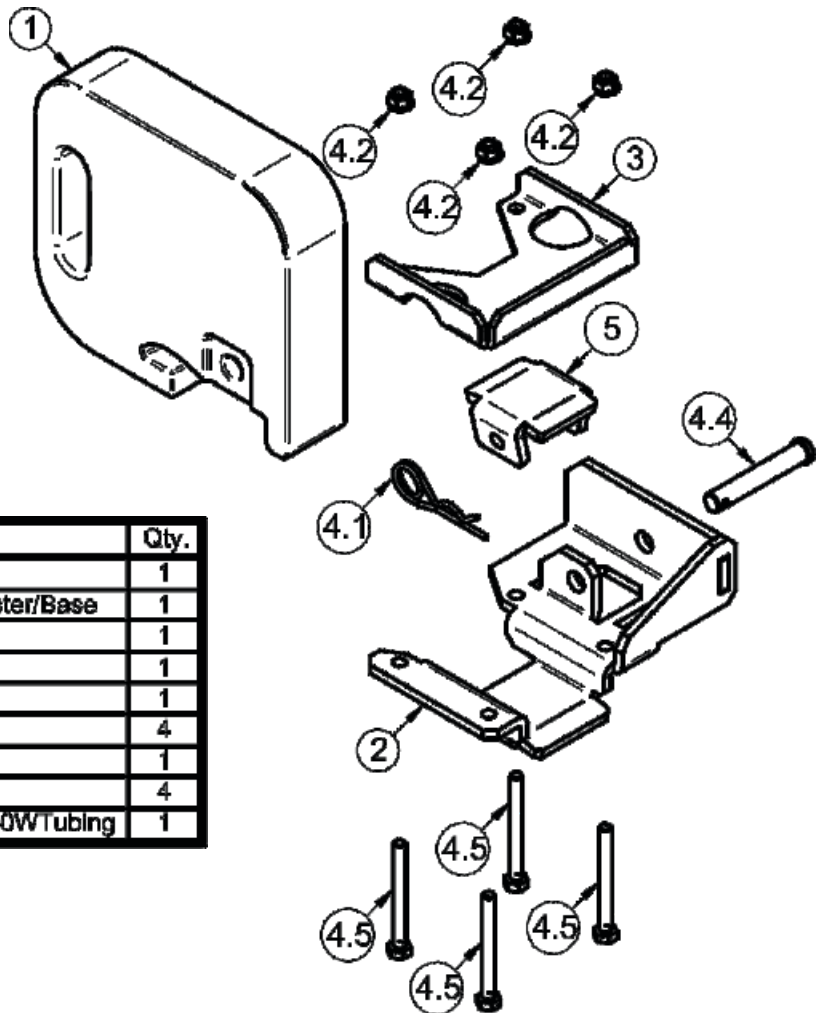

Item#	Part#	Desc.	Qty.
1	Y0025	28lb.SuitcaseWeight	1
2	B1022	SingleWeightBracket/RightCaster/Base	1
3	B1015	WeightBracket/Clamp	1
4	HB0686	SingleWeightKitHardwareBag	1
4.1	K1478	HairPinCotter/DoubleLoop	1
4.2	K2516	Ny-FlangeLockNut5/16"18	4
4.4	K1473	ClevisPin1/2x3"	1
4.5	K1472	HHCS5/16"18x3" GR5	4
5	B1089	WeightBracketClampInsert/1.50WTubing	1



Bag Assembly

First, take one of the Bag Ring Split Ends and insert it through the Bag Seam Opening. Next, rotate the Bag around the Bag Ring (1) full turn (360 degrees) until the Bag Ring Split Ends and the Bag Seam Opening are positioned on the same side. Then, connect the Bag Ring Split Ends using (1) End Connector. Last, rotate the Bag Ring and the End Connector Assembly (1/2") turn (180 degrees) to position the Connector opposite of the Bag Seam Opening. Note Final End Connector Location below in Figure A. Repeat for each Bag.

Figure A

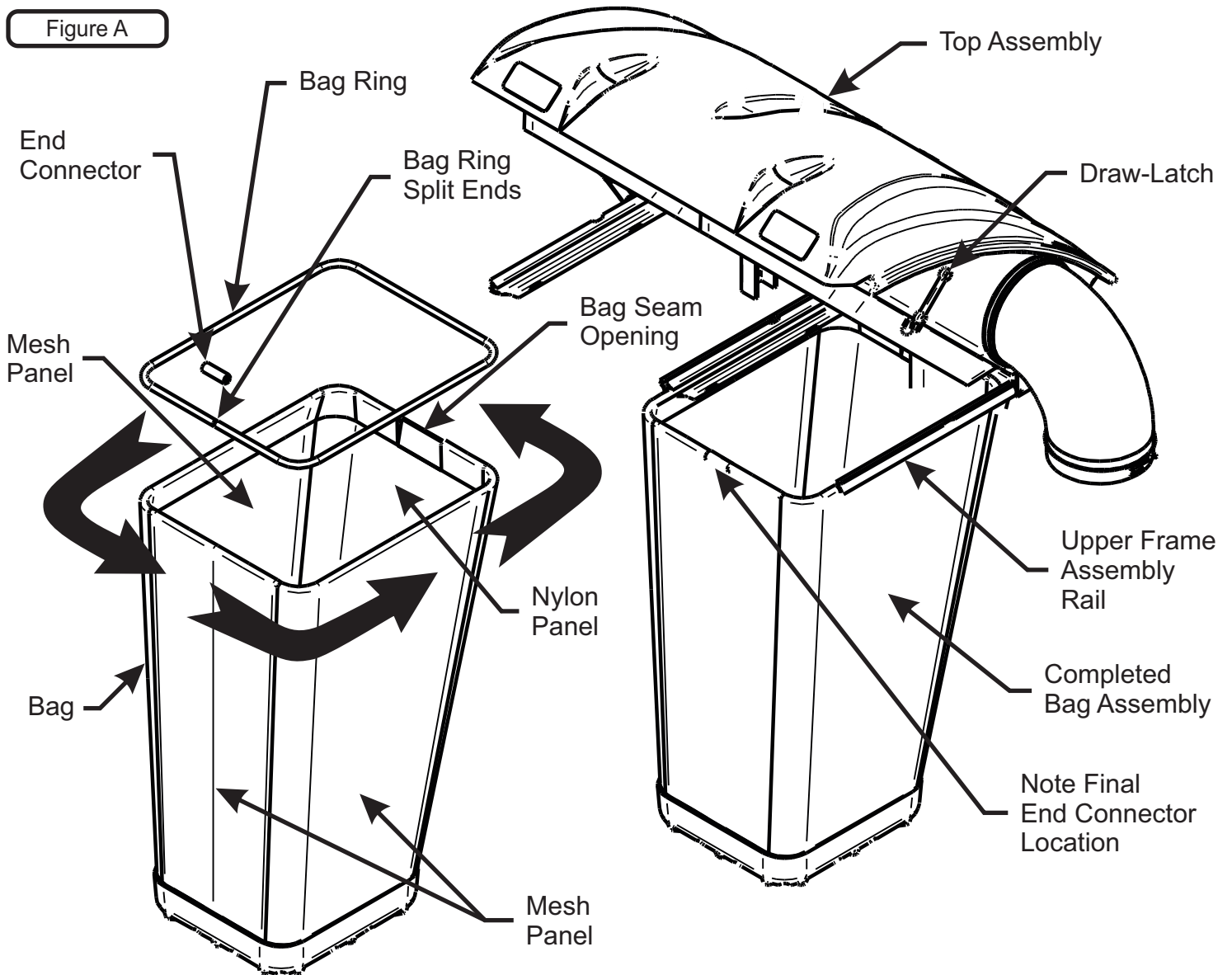

Bag Assembly Installation

Slide the Completed Bag Assembly into the Upper Frame Assembly Rails and close the Top Assembly. Fasten the Draw-Latch on either side to hold the bagger closed.

SECTION III OPERATING INSTRUCTIONS

General Safety

Only qualified people familiar with this operator's manual and the mower's operator's manual should operate this machine.

Operation And Tips On Mowing

- A. Perform BEFORE EACH USE the maintenance list referenced in Section IV.
- B. Start mower.
- C. With the mower at high idle speed, engage the mower deck.
- D. While seated in the operator's seat, pull the engagement handle of the PTO assembly towards the operator's seat until the handle slides into position in the retaining slot. With the PTO assembly engaged, you can proceed to operate the control levers of the mower.

NOTE: If the collection system does not appear to be collecting the grass clippings, disengage the deck and PTO assembly, then, engage the parking brake and turn the mower off. Check upper and lower hoses for any clogs.

To obtain the maximum effectiveness from your collection system, the tips listed below should be followed:

- * Watch your speed- Normal conditions will allow a speed of up to approximately 4 mph, but thick, heavy damp conditions will require reduced ground speed.
- * Mow with sharp blades- A sharp blade cuts cleaner.
- * Wet grass and leaves will decrease effectiveness and will increase horsepower requirements.
- * Mow at higher cutting heights- Remove and mulch no more than 2" of grass length with each mowing. (Experts recommend not cutting off more than 1/3 of the grass blade length at any given time.)
- * Mow twice, at different height settings, (high, then low), if grass is extra tall.
- * Remember that horsepower requirements will vary with the mowing conditions such as type and height of turf grass, moisture content, amount of leaves, whether the terrain is flat or hilly, etc.

Disengagement Of The PTO Assembly

A. To disengage the PTO assembly, slide the engagement handle out of the retaining slot and push the engagement handle away from the operator's seat.

WARNING: The PTO assembly blades will continue to spin. DO NOT TOUCH the PTO assembly, pulleys, or the belt until the tractor is turned off. DO NOT adjust the belt tension until the mower is turned off. Refer to the Belt Installation section of the manual.

Unloading The Collection System

NOTE: To determine when the collection bags are full, follow the following steps:

- A. Stop the forward movement of the mower.
- B. Disengage the mower deck.
- C. Disengage the PTO assembly.
- D. Engage the parking brake.
- E. Once the parking brake has been engaged, then and only then, walk behind the mower and check the collection bags by first unhooking the rubber strap with S-hook that secures the plastic top, then lift the plastic hood. Load in bags should not exceed the height of the installed bag.
- F. To remove the bags from the frame, slide bags out and turn bags over to deposit clippings.
- G. Slide empty bags back onto the frame and secure plastic top with the rubber strap with S-hook.

NOTE: Do not allow collection bags to become over-filled as potential damage may occur to your equipment. Also, be sure to clean the hood screen as needed.

SECTION IV MAINTENANCE

Maintenance Checklist

Before each use:

1. Check blades and spindles to be sure that no foreign objects, such as wire or steel strapping bands, are wrapped around them.
2. Inspect blades for wear. Replace if necessary. If it is necessary to sharpen the blades, remove the blades from the spindles before sharpening. DO NOT sharpen blades while still attached to the mower.

3. Make sure all shields are in place and in good condition. Repair or replace any missing or damaged shields.
4. Perform lubrication per instructions.
5. Listen for abnormal sounds, which might indicate loose parts, damaged bearings, or other damage. Correct any deficiency before continuing operation.
6. With the engine off, engage the blower assembly. Check the belt tension and inspect the pulley belt for cracks or tears.
7. Check for wear or deterioration of the upper or lower hoses. If there are any portions of the hose that have been torn or worn through, replace immediately.

After Each Use:

1. Clean all debris from machine especially from the container, underneath the belt shields, and safety decals. Replace any missing or illegible decals.
2. Inspect the unit for worn or damaged components. Repair or replace before the next use. Any replacement component installed during repair shall include the component's current safety decal specified by the manufacturers to be affixed to the component.
3. Under normal usage, the bag material is subject to deterioration and wear and should therefore be frequently checked for necessary replacement. Any replacement bag should be checked to ensure compliance with the original manufacturer's recommendations or specifications.
4. Check belt for proper tension.

Lubrication

Gearbox:

1. Every 20 hours of use: Check oil levels in gearbox.
2. First 60 hours of use: Change oil.
3. Every 100 hours of use: Change oil.

NOTE: Oil in gearbox should cover the gears. If not, drain the gearbox and fill using an 80W-90 gear oil. The gearbox ships with 6.0 oz. of oil, but we recommend replacing with a measured 5.5 oz. to fill the gearbox. **DO NOT OVERFILL!**

Blower Assembly:

NOTE: The following is for older PTO models that contain a greaseable zerc fitting. Newer models contain maintenance-free bearings and are without a greasable fitting.

1. On initial use: Grease the fitting on the blower shaft.
2. Every 25 hours of use: Re-grease the grease fitting.

NOTE: Use only white lithium based grease for lubrication of the shaft on the blower assembly.

SECTION V - PARTS & SERVICE

Parts And Service Information

Collection system owners should record the name and telephone number of their Service Center. Your Service Center will be happy to supply replacement parts, accessories, and do any service or repairs to your collection system. If for any reason your Service Center is unable to service your collection system or supply replacement parts, contact New PECO, Inc. and include the following information on the chart below.

DOCUMENT THE FOLLOWING INFORMATION FOR FUTURE REFERENCE

Unit Model Number: _____

Unit Engine Size: _____

Unit Serial Number: _____

Date of purchase: ____ / ____ / ____

Dealer/Distributor Name: _____

Address: _____ **State:** _____ **Zip:** _____

Phone Number: _____

New PECO, Inc.
10 Walden Dr | Arden, North Carolina 28704
Phone: 1-800-438-5823 | 828-684-1234
Fax: 828-684-0858
Email: peco@lawnvac.com
Website: www.lawnvac.com

Unit Model #: 37120901

Mower: Scag

Owner's Manual: Q0456

Mower Type: Freedom Z

Engine Type:

Deck Size: 48"

Vac Type: 9 Cu. Ft. Pro 2+ Bagger

Deck Type:

Drive Type: PTO-R Drive (3-Blade)

Revision #: 3 - MY & Weight Kit Update - 1/23/2018

Fits Year(s): 2010-Newer

A1902 Vac Kit

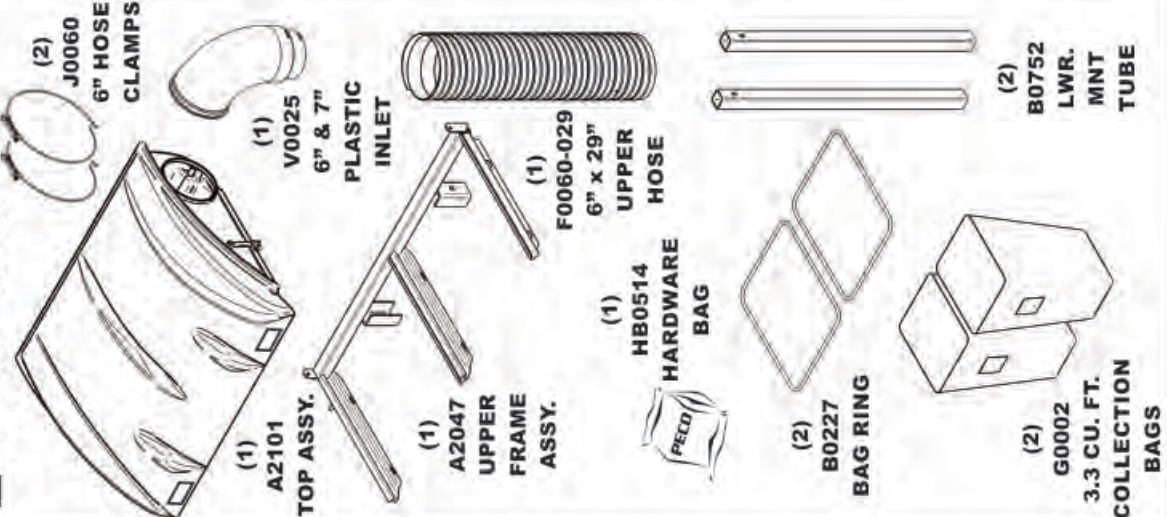

A1153 48" BAFFLE KIT



A1903 Mount Kit

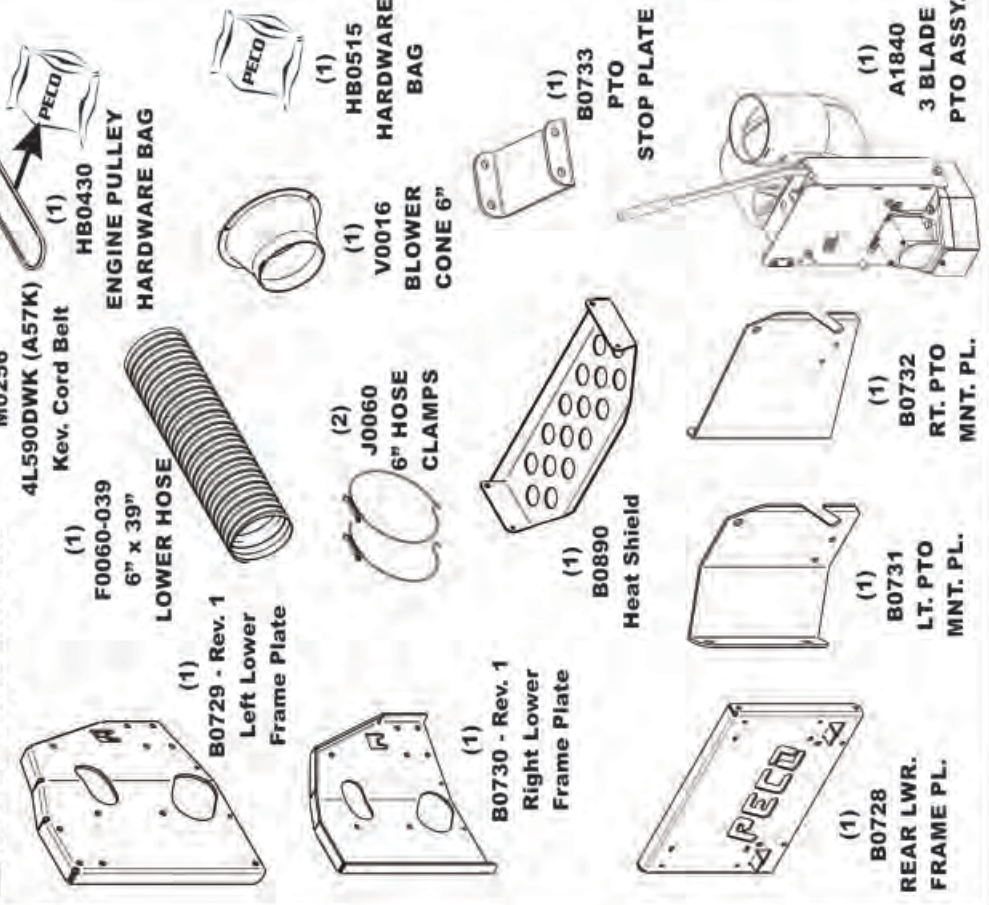

A1790 Boot Kit

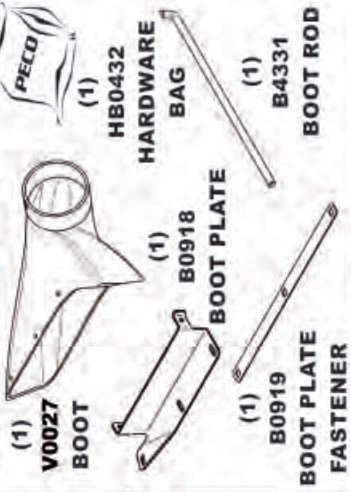

A2187 Dual Weight Kit

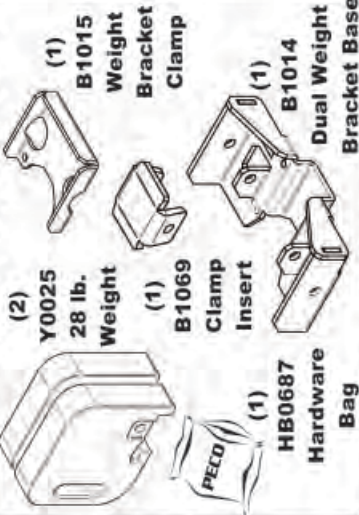

A2190 Weight Kit

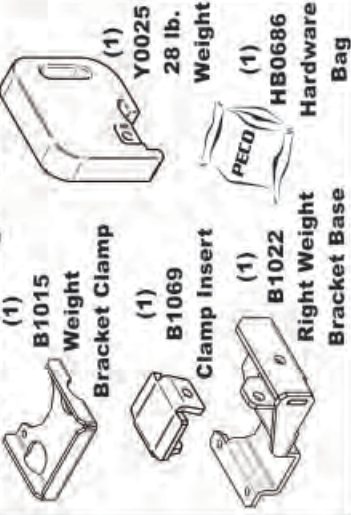

Unit Model #: 37120902

Mower: Scag

Owner's Manual: Q0456

Mower Type: Freedom Z

Engine Type: KW FS691V-AS13

Deck Size: 52"

Vac Type: 9 Cu. Ft. Pro 2+ Bagger

Deck Type:

Drive Type: PTO-R Drive (3-Blade)

Revision #: 3 - MY & Weight Kit Update - 1/23/2018

Fits Year(s): 2010-Newer

A1902 Vac Kit

- (1) A2101 TOP ASSY.
- (1) A2047 UPPER FRAME ASSY.
- (1) F0060-029 6" x 29" UPPER HOSE
- (1) HB0514 HARDWARE BAG
- (2) B0227 BAG RING
- (2) G0002 3.3 CU. FT. COLLECTION BAGS
- (2) J0060 6" HOSE CLAMPS
- (1) V0025 6" & 7" PLASTIC INLET
- (2) B0752 LWR. MNT TUBE

A1934 Mount Kit

- (1) B0729 - Rev. 1 Left Lower Frame Plate
- (1) B0730 - Rev. 1 Right Lower Frame Plate
- (1) F0060-039 6" x 39" LOWER HOSE
- (1) M0256 4L590DWK (A57K) Kev. Cord Belt
- (1) HB0522 ENGINE PULLEY HARDWARE BAG
- (1) V0016 BLOWER CONE 6"
- (2) J0060 6" HOSE CLAMPS
- (1) B0733 PTO STOP PLATE
- (1) B0890 Heat Shield
- (1) B0728 REAR LWR. FRAME PL.
- (1) B0731 LT. PTO MNT. PL.
- (1) B0732 RT. PTO MNT. PL.
- (1) A1840 3 BLADE PTO ASSY.

A1796 Boot Kit

- (1) V0028 BOOT
- (1) B0918 BOOT PLATE
- (1) B0919 BOOT PLATE FASTENER
- (1) B4331 BOOT ROD
- (1) HB0432 HARDWARE BAG
- (1) Y0025 28 lb. Weight

A2187 Dual Weight Kit

- (1) HB0687 Hardware Bag
- (2) Y0025 28 lb. Weight
- (1) B1069 Clamp Insert
- (1) B1015 Weight Bracket Clamp
- (1) B1014 Dual Weight Bracket Base

A2190 Weight Kit

- (1) B1015 Weight Bracket Clamp
- (1) B1069 Clamp Insert
- (1) B1022 Right Weight Bracket Base
- (1) Y0025 28 lb. Weight
- (1) HB0686 Hardware Bag



**TOP ASSEMBLY
EXPLODED PARTS VIEW**

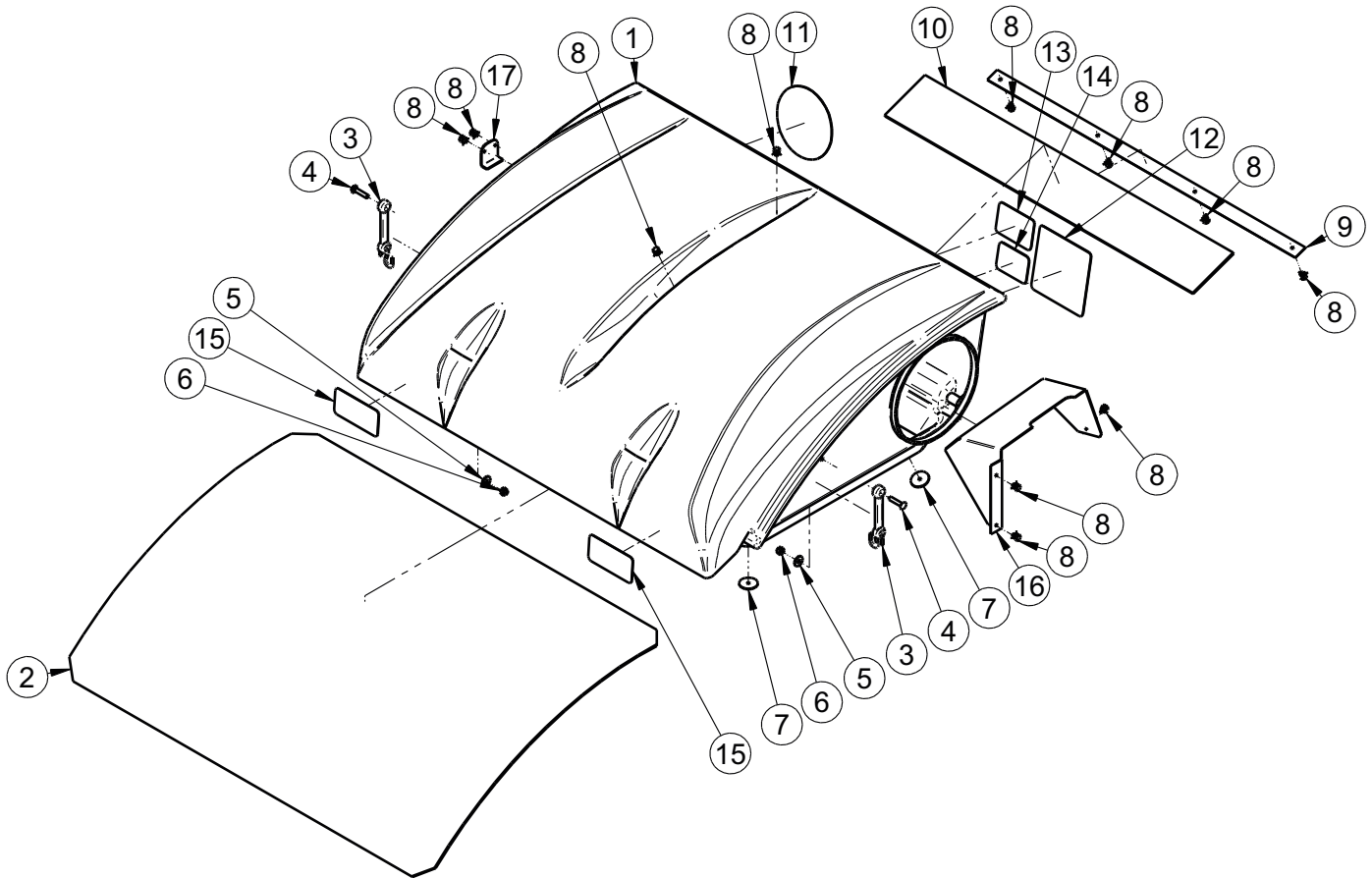

Item #	Part #	Desc.	Qty.
1	V2000	Pro 2 Bagger Top / Gen. 2	1
2	V2001	Screen	1
3	J4009	Short Rubber Strap w/ S-Hook	2
4	K1030	1/4"-20 x 1-1/4" Carriage Bolt	2
5	K0037	Flat Washer / 1/4" (.75 OD x .312 ID x .060 T)	2
6	K1128	1/4"-20 Nyloc Nut	2
7	K0062	3/16" x 1-1/2" Fender Washer, Z	2
8	K0114	Black Plastic Rivet	11
9	C0067	Dust Guard Mnt. Brkt.	1
10	V1117	Dust Guard	1
11	R0022	Decal / Built In The USA / Lg	1
12	R1069	Decal / Warning - Turn Off Blower	1
13	R1054	Decal / Important Check Hoses	1
14	R1051	Decal / Warning - Use Hearing Protection	1
15	R1057	Decal / 2" x 4" Red Reflector	2
16	C0026	Grass Deflector	1
17	B0676	Hinge Stop Pl.	1

A1840 PTO ASSEMBLY EXPLODED PARTS VIEW DESCRIPTION

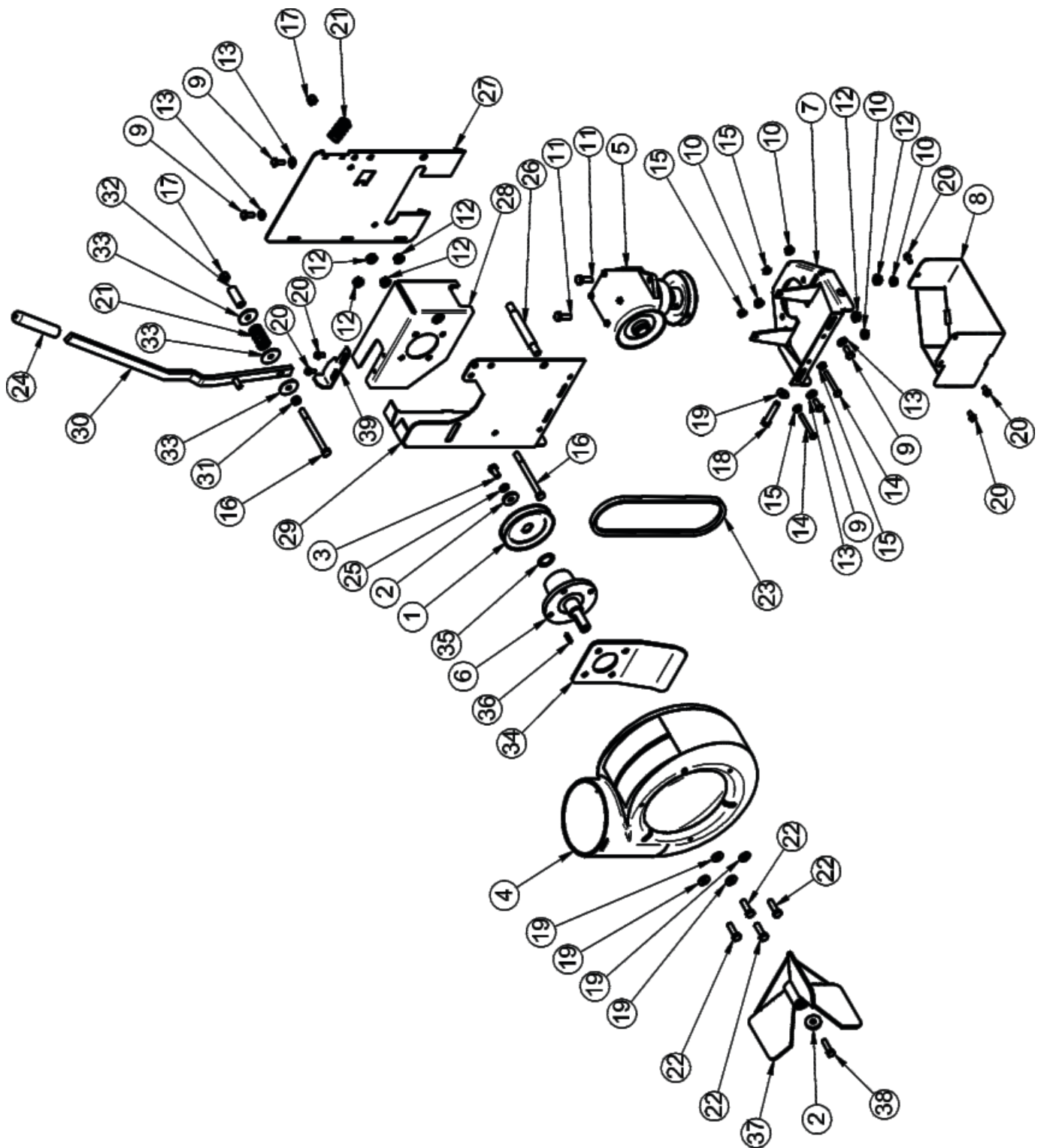

**A1840 PTO ASSEMBLY
EXPLODED PARTS VIEW**

Item#	Part#	Desc.	Qty.
1	M0266	A-SectionPulley/4.25OD	1
2	K1446	PTOHousingWasher	2
3	K1190	HHCS/3/8"-16x3/4"	1
4	V0015	BlowerHsg.	1
5	A0429	GearBoxAssy.	1
6	A1004	PTOShaftAssy.	1
7	A1003	PTOBasePlateAssy.	1
8	B0478	GearBoxPulleyGuard	1
9	K1153	HHCS5/16"-18x3/4"	4
10	K1178	FlangeNut5/16"-18	4
11	K1191	HHCS3/8"-16x1" GR5	2
12	K1215	FlangeNut3/8"-16	6
13	K0037	FlatWasher/1/4"(.75ODx.312IDx.060T)	4
14	K1150	HHCS/1/4"-20x2-1/4"	2
15	K1126	FlangeNut1/4"-20	4
16	K1202	HHCS/3/8"-16x4-1/2"/G5	2
17	K1216	NylocNut/3/8"-16	2
18	K0348	HHCS/3/8"-16x2" AllThread	1
19	K0042	FlatWasher5/16".875ODx.380IDx.075T	5
20	K0353	HWHTCS1/4"-20x1/2"	5
21	J0303	Spring	2
22	K1192	HHCS3/8"-16x1-1/4"GR5	4
23	M0267	KevlarBelt/A28K	1
24	V1151	BlackHandleGrip(5/8"IDx4-3/4" L)	1
25	K0048	LockWasher3/8"	1
26	B0505	MountRod	1
27	B0506	Lt.PTOArm	1
28	B0642	MountBracket/BlowerHsg.	1
29	B0643	Rt.PTOArm	1
30	A1112	PTOHandleAssembly	1
31	B0510	SpacerBushing/Small	1
32	B0511	SpacerBushing/Large	1
33	K0403	FlatWasher(1-1/2"ODx3/8" IDx.092T)	3
34	B0739	StiffenerPlate/BlowerHsg.	1
35	K0070	FlatWasher(1.295ODx.881IDx.020T)	1
36	J0254	Key/3/16"x3/16" x3/4"	1
37	A1839	3-BladeImpellerAssy.	1
38	K1171	HHCS/5/16"-24LHx1-1/4"/G5w/PatchCoating	1
39	B0887	BeltTensionAdjustBracket	1

SAFETY DECALS

To promote safe operation, PECO Inc. supplies safety decals on all products manufactured. Damage can occur to safety decals either through shipment, use or reconditioning. Contact your local Service Center for replacement decals.



Part #: R1070
PECO Label



Part #: R2007
Never Use Hands Label

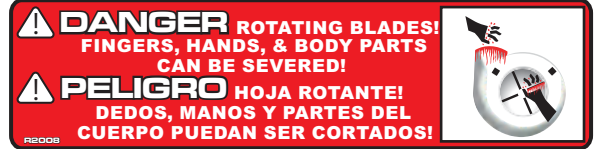

Part #: R2008
Rotating Blades Label



Part #: R1100
Engage-Disengage Label



Part #: R4037
Warning: Hot Surface Label



Part #: R1052
Small Warning: Turn Off Blower Label

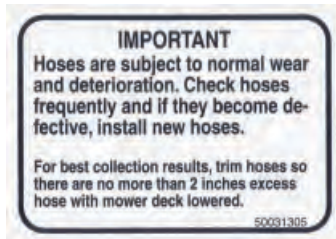

Part #: R1054
Important Label



Part# R0022
Designed & Built In The USA



Part #: R1069
Warning: Turn Off Blower Label



Part #: R1051
Warning: Hearing Protection Label



Part #: R4015
Danger: Rotating Blades Label



Part #: R4008
Caution: Rotating Blades Label

TORQUE SPECIFICATIONS

AMERICAN Bolt Head Markings



SAE Grade 2
(No Dashes)

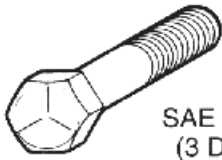

SAE Grade 5
(3 Dashes)

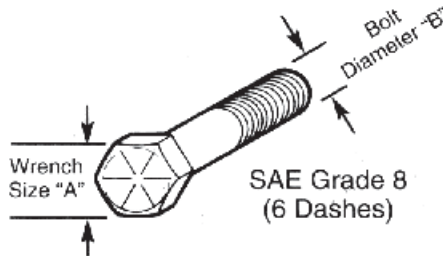

SAE Grade 8
(6 Dashes)

Recommended Torque in Foot Pounds (Newton Meters).*

WRENCH SIZE (IN.) "A"	BOLT DIAMETER (IN.) "B" AND THREAD SIZE	SAE GRADE 2	SAE GRADE 5	SAE GRADE 8
7/16	1/4 - 20 UNC	6 (7)	8 (11)	12 (16)
7/16	1/4 - 28 UNF	6 (8)	10 (13)	14 (18)
1/2	5/16 - 18 UNC	11 (15)	17 (23)	25 (33)
1/2	5/16 - 24 UNF	13 (17)	19 (26)	27 (37)
9/16	3/8 - 16 UNC	20 (27)	31 (42)	44 (60)
9/16	3/8 - 24 UNF	23 (31)	35 (47)	49 (66)
5/8	7/16 - 14 UNC	32 (43)	49 (66)	70 (95)
5/8	7/16 - 20 UNF	36 (49)	55 (75)	78 (106)
3/4	1/2 - 13 UNC	49 (66)	76 (103)	106 (144)
3/4	1/2 - 20 UNF	55 (75)	85 (115)	120 (163)
7/8	9/16 - 12 UNC	70 (95)	109 (148)	153 (207)
7/8	9/16 - 18 UNF	79 (107)	122 (165)	172 (233)
15/16	5/8 - 11 UNC	97 (131)	150 (203)	212 (287)
15/16	5/8 - 18 UNF	110 (149)	170 (230)	240 (325)
1-1/8	3/4 - 10 UNC	144 (195)	266 (360)	376 (509)
1-1/8	3/4 - 16 UNF	192 (260)	297 (402)	420 (569)
1-5/16	7/8 - 9 UNC	166 (225)	430 (583)	606 (821)
1-5/16	7/8 - 14 UNF	184 (249)	474 (642)	668 (905)
1-1/2	1 - 8 UNC	250 (339)	644 (873)	909 (1232)
1-1/2	1 - 12 UNF	274 (371)	705 (955)	995 (1348)
1-1/2	1 - 14 UNF	280 (379)	721 (977)	1019 (1381)
1-11/16	1-1/8 - 7 UNC	354 (480)	795 (1077)	1288 (1745)
1-11/16	1-1/8 - 12 UNF	397 (538)	890 (1206)	1444 (1957)
1-7/8	1-1/4 - 7 UNC	500 (678)	1120 (1518)	1817 (2462)
1-7/8	1-1/4 - 12 UNF	553 (749)	1241 (1682)	2013 (2728)
2-1/16	1-3/8 - 6 UNC	655 (887)	1470 (1992)	2382 (3228)
2-1/16	1-3/8 - 12 UNF	746 (1011)	1672 (2266)	2712 (3675)
2-1/4	1-1/2 - 6 UNC	870 (1179)	1950 (2642)	3161 (4283)
2-1/4	1-1/2 - 12 UNF	979 (1327)	2194 (2973)	3557 (4820)

METRIC

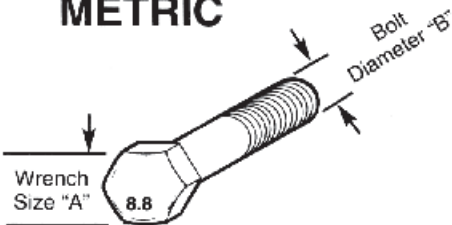

Numbers appearing on bolt heads indicate ASTM class.

Recommended torque in foot pounds (newton Meters).*

WRENCH SIZE (mm) "A"	BOLT DIA. (mm) "B"	ASTM 4.6	ASTM 8.8	ASTM 9.8	ASTM 10.9
8	5	1.8 (2.4)		5.1 (6.9)	6.5 (8.8)
10	6	3 (4)		8.7 (12)	11.1 (15)
13	8	7.3 (10)		21.1 (29)	27 (37)
16	10	14.5 (20)		42 (57)	53 (72)
18	12	25 (34)	74 (100)	73 (99)	93 (126)
21	14	40 (54)	118 (160)	116 (157)	148 (201)
24	16	62 (84)	167 (226)	181 (245)	230 (312)
30	20	122 (165)	325 (440)		449 (608)
33	22		443 (600)		611 (828)
36	24	211 (286)	563 (763)		778 (1054)
41	27		821 (1112)		1138 (1542)
46	30	418 (566)	1119 (1516)		1547 (2096)

*Use 75% of the specified torque value for plated fasteners. Use 85% of the specified torque values for lubricated fasteners.

NOTES



**10 WALDEN DRIVE
ARDEN, NORTH CAROLINA 28704
(800) 438-5823 OR (828) 684-1234 FAX: (828) 684-0858
EMAIL: peco@lawnvac.com
WEBSITE: www.lawnvac.com**