



**PTO
GRASS COLLECTION
SYSTEM**

**DESIGNED FOR:
CUB CADET TANK**

MODEL# 21131205



OPERATOR'S MANUAL

ASSEMBLY • OPERATION • MAINTENANCE

PECO GRASS COLLECTION SYSTEM

TABLE OF CONTENTS

SECTION	PAGE	SECTION	PAGE
Safety	2	2-13 Length Of Hose Adjustment	10
Safety Alert Symbols	3	2-14 Upper Hose Installation	10
Warranty	4	2-15 Lower Hose To Blower Cone Installation	10
I INTRODUCTION AND DESCRIPTION	5	2-16 Lower Hose To Boot Installation	10
1-1 Introduction	5	2-17 Front Weight Installation	10
1-2 Description	5	2-18 Installation Of Collection Bags	11
II INSTALLATION FOR USE	5	Exploded Part Views and Assemblies	12-15
2-1 Preparation Of Mower	5	III OPERATING INSTRUCTIONS	16
2-2 Lower Mount Plate and PTO Mount Plate Assembly Installation	6	3-1 General Safety	16
2-3 Lower Mount Assembly Installation	6	3-2 Operation & Tips On Mowing	16
2-4 Universal PTO Assembly Installation	6	3-3 Disengagement Of The Blower	16
2-5 Belt Installation And Adjustment	7	3-4 Unloading The Collection System	16
2-6 Cam Assembly Adjustment	7	IV MAINTENANCE	16
2-7 Exhaust Deflector Installation	7	4-1 Maintenance Checklist	16
2-8 Upper Frame Assembly Installation	8	4-2 Lubrication	17
2-9 Top Assembly Installation	8	V PARTS AND SERVICE	17
2-10 Boot To Mower Deck installation	8	5-1 Parts And Service Information	17
2-11 Blower Cone Installation	9	Safety Decals	18
2-12 Impeller Blade Removal/Replacement	9	Torque Specifications	19

Safety

1. Read the operator's manual carefully and familiarize yourself with the proper use of your attachment. Do not allow anyone who is not acquainted with the Safety Instructions to use your attachment.
2. Know the controls and how to stop quickly. READ THE OPERATOR'S MANUAL!
3. Do not allow children to operate the vehicle. Do not allow adults to operate it without proper instruction.
4. Be especially watchful of children and pets darting into the area while operating.
5. Keep your eyes and mind on your unit while mowing or operating your attachment. Don't let others distract you.
6. Do not attempt to operate your unit or mower when not in the driver's seat.
7. Always stop unit when emptying the container.
8. Stop unit, shut off deck attachment, set parking brake, shut off mower engine and remove spark plug wire before removing clogs, removing or replacing hose, boot, blower cone, or performing any maintenance.
9. Mow the face of slopes (not steeper than 10 degrees); never up and down the face of the slope.
10. It is recommended that the container be kept only half full when negotiating any slopes. Start mowing on slopes when the container is empty.
11. Inspect your lawn and remove any foreign objects before mowing. Never deliberately run the mower across any foreign object.
12. Wear ear protection if the noise level is offensive.
13. Wear eye protection to prevent debris from damaging your eyes.

SAFETY

WARNING! **NEVER** operate the mower unless the discharge guard and either the deflector assembly or the vacuum collector adapter are fastened securely in place.

WARNING! Do not work around the mower deck boot or the blower area until you are certain that the mower blades and the blower impeller have stopped rotating.

WARNING! To avoid serious injury, perform maintenance on the vacuum collector; **ONLY AFTER STOPPING THE MOWER'S ENGINE AND WAITING FOR ALL MOVING PARTS TO COME TO A COMPLETE STOP.** Set the parking brake. Always remove the ignition key before beginning maintenance.

WARNING! For your own personal safety, **ALWAYS** mow **ACROSS** the face of slopes and **NEVER UP and DOWN** the face. **NEVER** attempt to mow excessively steep slopes, and use caution when turning on any slope.

Safety Alert Symbol



This Safety Alert Symbol means: **“ATTENTION! BECOME ALERT! YOUR SAFETY IS INVOLVED!”**

This symbol is used to call attention to safety precautions that should be followed by the operator to avoid accidents. When you see this symbol, carefully read the message that follows and heed its advice. Failure to comply with safety precautions could result in death or serious bodily injury.

Safety Signs

The signal words **DANGER**, **WARNING**, and **CAUTION** are used on the equipment safety signs. These words are intended to alert the viewer to the existence and the degree of hazard seriousness.



White letters on **RED**

This signal word indicates a potentially hazardous situation which, if not avoided, will result in death or serious injury.



Black letters on **ORANGE**

This signal word indicates a potentially hazardous situation which, if not avoided, could result in death or serious injury.

It may also be used to alert against unsafe practices.



Black letters on **YELLOW**

This signal word indicates a potentially hazardous situation exist which, if not avoided, will result in minor or moderate injury.

It may also be used to alert against unsafe practices.

PECO LIMITED WARRANTY FOR NEW PRODUCTS

A. WHAT IS WARRANTED?

PECO extends the following warranties to the original purchaser of each new PECO consumer product subject to the following limitations:

1. PRODUCT WARRANTY: Any part of any consumer product, which is defective in material or workmanship as delivered to the purchaser will be repaired or replaced, as PECO elects, without charge for parts or labor, if the defect appears within 12 months from the date of delivery of the product to the original purchaser. **ALL DEFECTIVE PARTS MUST BE RETURNED TO PECO FOR INSPECTION TO DETERMINE VALIDITY OF WARRANTY CLAIMS.** Freight and mailing will be borne by the customer.

2. PARTS REPLACED DURING WARRANTY: Any new PECO part which is furnished in performance of this warranty and is defective in material or workmanship as delivered to the purchaser will be repaired or replaced, as PECO elects, without charge if the defect appears within 90 days from the date of installation of such part or before the expiration of the original warranty period, whichever is later.

B. SECURING WARRANTY ADJUSTMENTS.

Call PECO for Return Authorization. Damaged or broken parts, other than engines or batteries, must be returned to PECO Inc., 100 Airport Road, Arden, NC 28704 before any warranty adjustment can be authorized. At the time of requesting warranty adjustment, the purchaser must present evidence for date of delivery of the product. The purchaser shall pay any charge for the product to and from Arden, NC.

C. ITEMS NOT COVERED BY PECO WARRANTY.

Engines and batteries attached to PECO products are covered under a separate warranty by the respective manufacturer.

D. UNAPPROVED ALTERATION OR MODIFICATION.

All obligations of PECO Inc., under this warranty, shall be terminated if products are altered or modified in ways not approved by PECO Inc..

E. ACCIDENTS AND NORMAL MAINTENANCE.

The warranty covers only defective material and workmanship. It does not cover depreciation or damage caused by normal wear, accident, improper use or abuse of products. The cost of normal maintenance and normal replacement of service items such as belts, cutting blades, hoses, etc., which are not defective shall be paid for by the purchaser.

F. NO REPRESENTATIONS ADDITIONAL WARRANTIES, DISCLAIMER.

Neither PECO Inc. nor any company affiliated with it makes any warranties, representations or promises as to the quality of performance of its products other than those set forth herein. Except as described above, PECO Inc. makes no other warranties **AND SPECIFICALLY DISCLAIMS ANY AND ALL IMPLIED WARRANTIES OF FITNESS AND MERCHANTABILITY.**

G. ANY MACHINE USED FOR RENTAL PURPOSES ARE GUARANTEED FOR 45 DAYS FROM DATE OF ORIGINAL SALE ONLY.

H. REMEDIED EXCLUSIVE.

The only remedies the purchaser has in connection with the breach or performance of any warranty on PECO Inc. consumer products are set forth above. In no event will PECO be liable for special incidental or consequential damages.

1. NO SERVICE CENTER WARRANTY.

The selling Service Center makes no warranty on his own on any item warranted by PECO Inc. unless he delivers to purchaser a separate written warranty certificate specifically warranting the item. The dealer has no authority to make any representation or promise on behalf of PECO or to modify the terms of this warranty in any way.

SECTION I

INTRODUCTION AND DESCRIPTION

1-1 Introduction

We are pleased to have you as a PECO customer. Your collection system has been designed to give you a low maintenance, simple, and effective way to collect the grass clippings from your mower. This manual is provided to give you the necessary instructions to properly mount and operate the collection system on your mower. Please read this manual thoroughly. Understand what each control is for and how to use it. Observe all safety decal precautions on the machine and noted throughout the manual.

NOTE: all references made to right, left, front, rear, top or bottom are as viewed from the normal operator's position on the mower.

1-2 Description

The collection system is designed for turf maintenance where there is a need to collect the grass clippings as the mower cuts the turf. It is also good for picking up leaves and twigs in pre-season and post-season clean-up.

The blower, mounted on the right side of the unit, uses a belt and gearbox system from the engine PTO shaft. Drive train protection comes through belt slippage. The blower draws grass clippings from the discharge area of the cutter deck up to the aluminum container mounted over the rear portion of the mower frame. The operator can engage the blower with a push of the over-center linkage on the right side of the unit. Once the container is full of clippings, the operator can easily push and raise the lift handle, releasing the container's rear door and the container will pivot towards the ground.

Section II

INSTALLATION FOR USE

2-1 Preparation Of Mower

Carefully dismantle wooden shipping crate from around the components. Cut retaining straps and separate the parts. The collection system will have various parts located inside. Remove and sort all parts for easy identification.

NOTE: Before each step of assembly it will help to study the exploded drawings on pages 12 through 15.

From the underside of the engine remove the bolt and bushing from the electric clutch assembly. It will help to use a bungee cord or similar device to hold the electric clutch in place during this step.

Replace these parts with the engine pulley assembly P#(A1109), (1) 7/16" lock washer P#(K0140), (1) keyway P#(K1627) and (1) 7/16"-20 x 3/4" HHCS P#(K0350). The added pulley will power the collection system. Note that the center of the hub that is extended should be upward toward the engine. Torque the bolt to 55 ft./lbs. Refer to Figure 2-1a.

Figure 2-1a

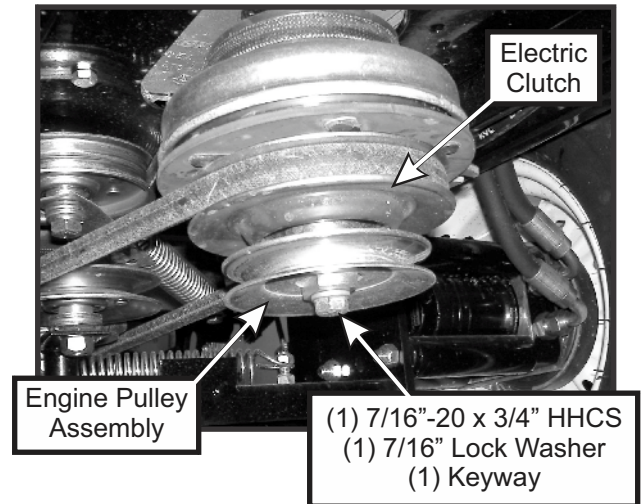

Remove the engine guard from the mower. The engine guard is secured to the frame of the mower with (2) 1/2"-13 hex bolts. Save the existing hardware for use later in the installation procedure. Refer to Figure 2-1b.

Figure 2-1b

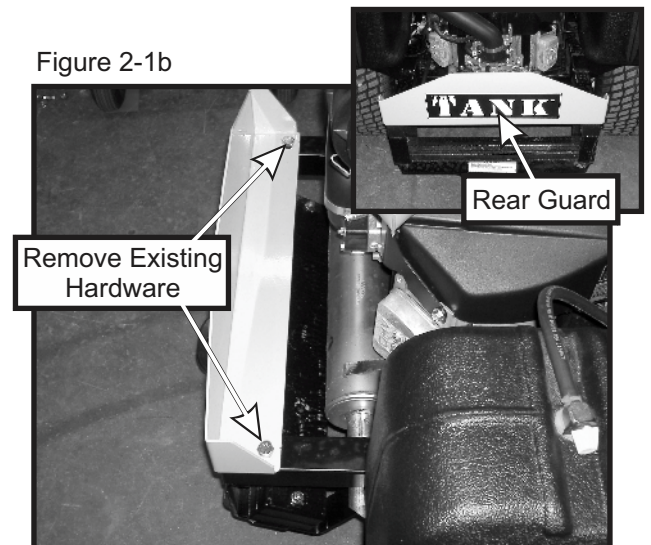

2-2 Lower Mount Plate And PTO Mount Plate Assembly Installation

Fasten the lower mount plate P#(B0395) and the PTO mount plate assembly P#(A0846) to the rear frame of the mower using the (2) existing bolts and (2) nuts removed from the engine guard and (2) 1/2"-13 x 1" HHCS P#(K1231) and (2) 1/2"-13 nyloc nuts P#(K1247). See Figure 2-2.

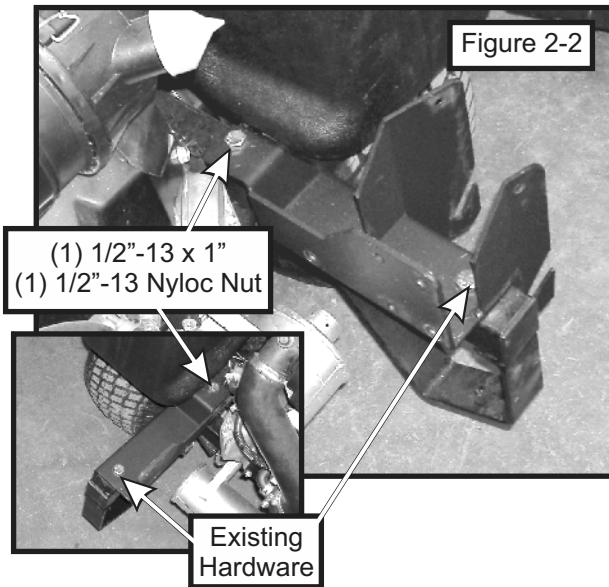

2-3 Lower Mount Assembly Installation

Fasten the lower mount assembly P#(A0848) to the left lower mount plate P#(B0395) and the PTO mount plate assembly P#(A0846) using (6) 3/8"-16 x 1" HHCS P#(K1191) and (6) 3/8"-16 flange nuts P#(K1215). See Figure 2-3 for reference.

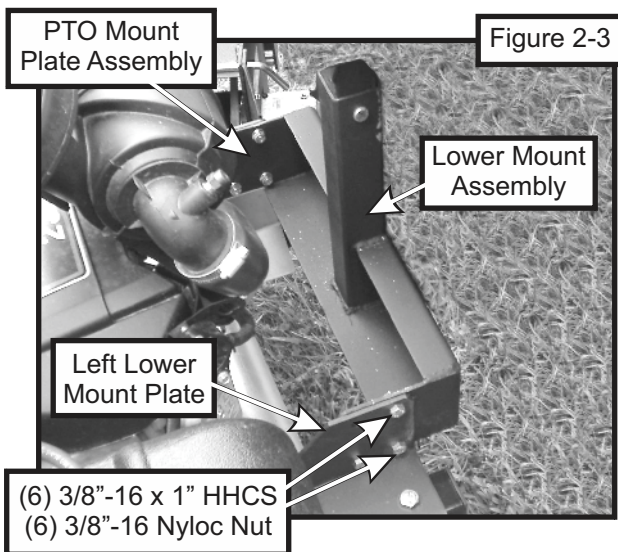

2-4 Universal PTO Installation

To mount the PTO assembly, insert the mount rod on the PTO assembly P#(A0623) into the mounting slots located on the PTO mount plate assembly P#(A0846). Wrap the kevlar belt around both pulleys, tilt the PTO assembly forward and insert the PTO assembly mount pin P#(B0274) through the hole in the top of the PTO mount plate assembly and through the PTO assembly. Secure the PTO mount pin using 1/8" x 2-1/2" hair pin clip P#(K0086). See Figure 2-4a.

Figure 2-4a

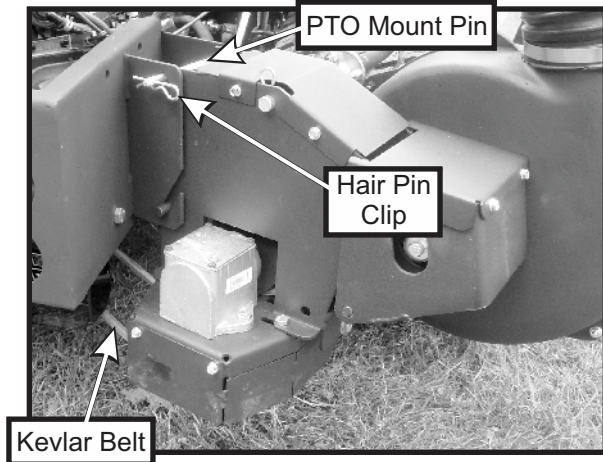

Mount the PTO handle assembly P#(A0603) to the universal PTO P#(A0623) using (3) 1/4"-20 x 3/4" HHCS P#(K1222) and (3) 1/4"-20 nyloc nuts P#(K1128). Before fastening, make sure that there is room for the handle to engage and disengage without the handle hitting the mower's fuel tank. See Figure 2-4b for reference.

Figure 2-4b

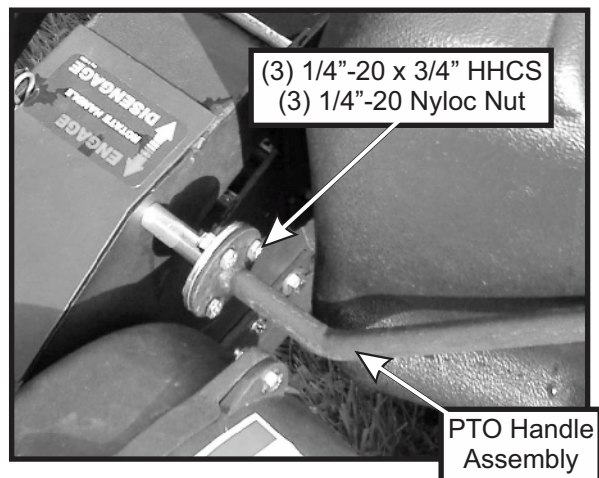

2-5 Belt Installation

Loosen the (4) bolts P#(K1191), (2) on each side, that secure the gear box assembly to the PTO assembly P#(A0623) (Figure 2-5a and 2-5b). Loosen the adjustment bolt P#(K0348) until the gear box assembly is at its far left adjustment (the gear box is moved toward the mower's engine pulley). Connect the kevlar cord belt A61K P#(M0261) from the engine pulley to the lower gear box pulley (Figure 2-5c). To tension the drive belt, turn the adjustment bolt clockwise (Figure 2-5d) until there is 1" of deflection, with 10-11 lbs. of pressure, at the center of the belt between the engine pulley and the gear box pulley. Once the correct tension of the belt is achieved, tighten the (4) bolts that secure the gear box assembly.

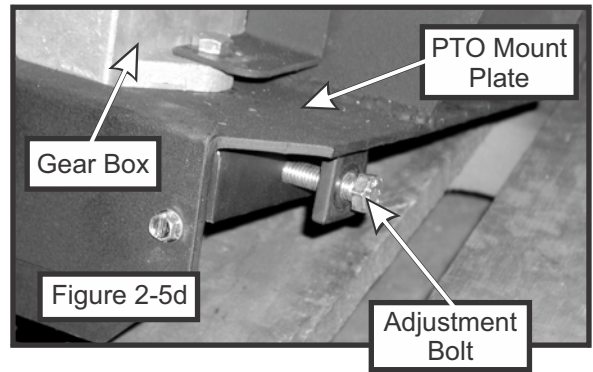
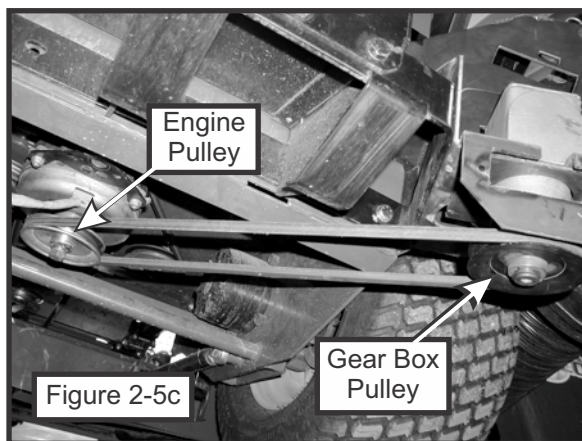
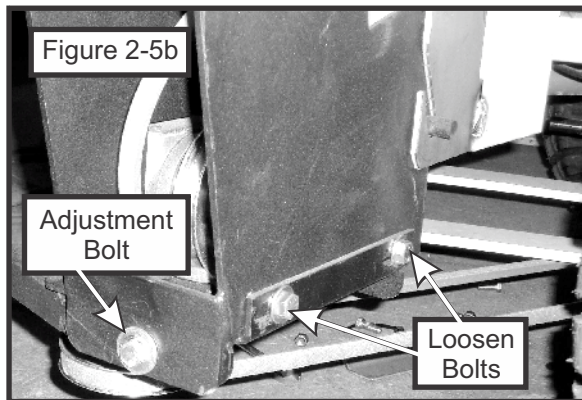
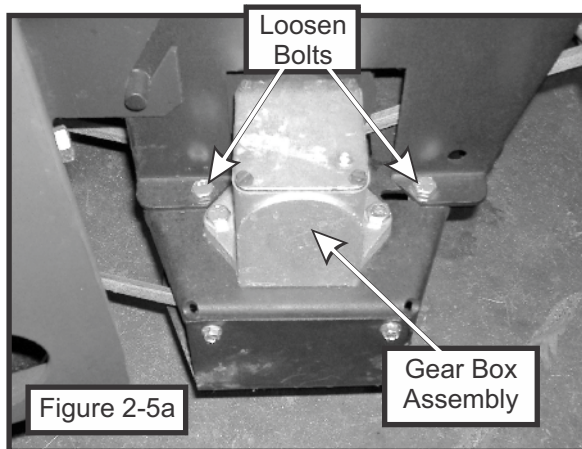

2-6 Cam Assembly Adjustment

The cam assembly P#(A0422), which controls the blower belt tension, comes from the factory pre-adjusted. If the belt is too tight or becomes too loose, remove the hair pin clip P#(K0099) from the belt tension rod P#(K0326) and pull the "L" end of the rod out of its hole in the cam assembly. The tension rod may then be screwed out to tighten the belt or screwed in to loosen the belt. Replace the "L" end into the top hole in the cam and replace the hair pin clip. Adjust the cam stop bolt P#(K1159) to allow the cam to rotate slightly over center when the blower is disengaged (Figure 2-6).

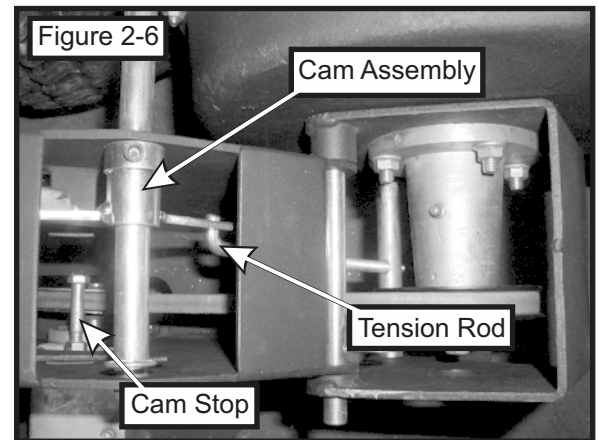

2-7 Exhaust Deflector Installation

Fasten the exhaust deflector P#(C0058) to the underside of the PTO mount plate assembly P#(A0846) and fasten using (2) 1/4"-20 x 3/4" HHCS and (2) 1/4"-20 nyloc nuts. See Figure 2-7.

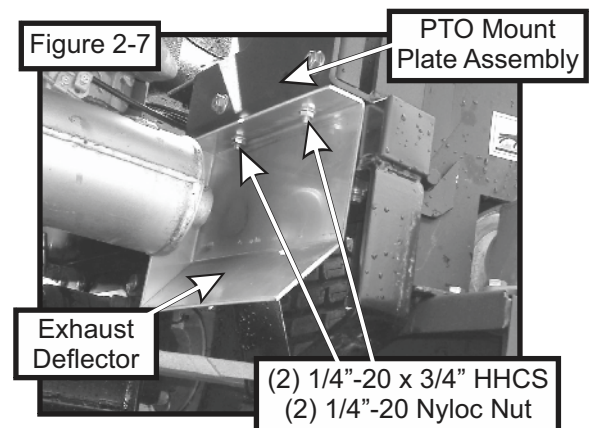

2-8 Upper Frame Assembly Installation

NOTE: During this step, it is suggested that two people install the upper frame to the lower mount tube.

Using (2) people to lift the upper frame, lift the upper frame P#(A1838) above the lower mount assembly P#(A0848) making sure the frame is pointing away from the mower (Figure 2-8). Slide the upper frame tube into the lower mount assembly aligning the mounting hole. Insert (1) 1/2" x 2-1/2" clevis pin P#(K0133) through the hole and fasten with (1) 5/32" x 2-5/8" hair pin clip P#(K0088).

Figure 2-8

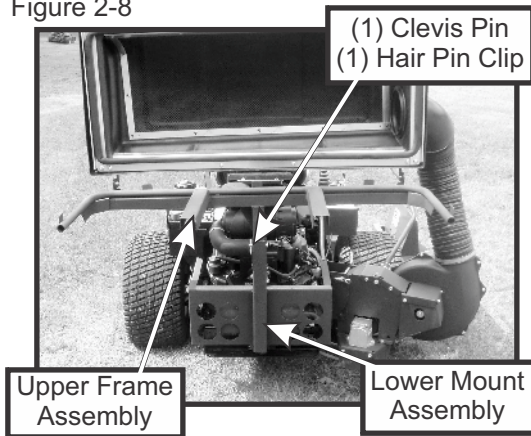

2-9 Top Assembly To Upper Frame Assembly Installation

Position the top assembly P#(A1158) above the upper frame assembly as shown in Figure 2-7. Fasten the top assembly to the upper frame assembly using (2) 5/16"-18 x 2-1/2" HHCS P#(K0125) and (2) 5/16"-18 nylon flange locknuts P#(K2516). Leave the locknuts slightly loose, to allow the top assembly to open and close easily. Refer to Figure 2-9 for hardware location.

Figure 2-9

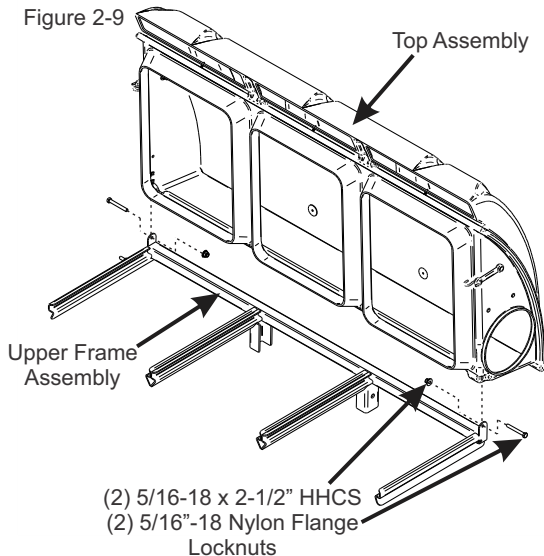

2-10 Boot To Mower Deck Installation

Remove the grass deflector (Figure 2-10a) from the mower deck by lifting the deflector and removing the deflector rod and spring (Figure 2-10b). Remove the deck finger guard and existing hardware (Figure 2-10b).

Figure 2-10a

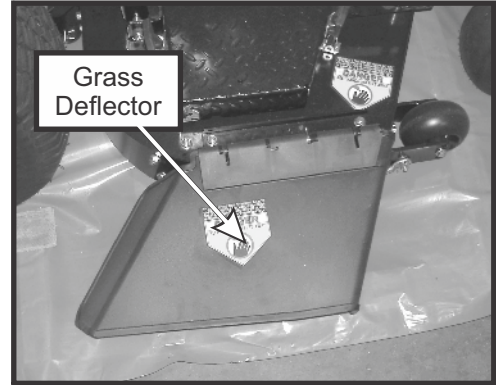
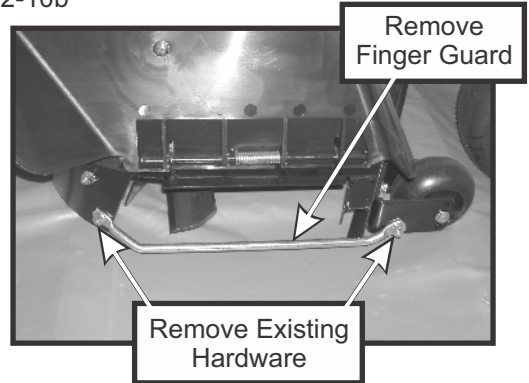
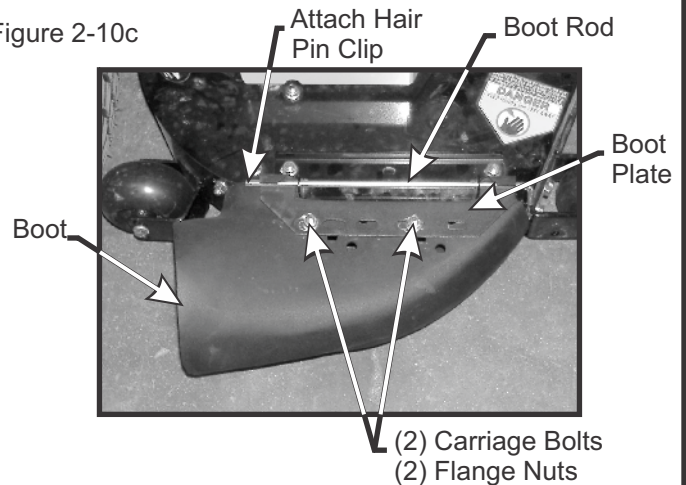

Figure 2-10b



Fasten the boot plate P#(B2555) to the boot P#(E1031) using (2) 3/8"-16 x 1" carriage bolts and (2) 3/8"-16 nylon nuts P#(K1216). Insert the carriage bolt from the inside of the boot before fastening, to prevent grass from potentially building up on the threads. Insert the boot rod P#(B4331) into the holes on the mower deck, fasten with a (1) hair pin clip P#(K0099), then attach the boot and boot plate to the mower deck (Figure 2-10c).

Figure 2-10c



2-11 Blower Cone Installation

Thread (1) 5/16"-18 jam nut P#(K0120) onto each end of (2) 5/16"-18 x 2-1/2" HHCS P#(K0125). Now partially thread the bolts into each of the two tabs located on the blower housing. Place blower cone so the two tabs line up with the bolts then tighten completely. See Figure 2-11.

Figure 2-11

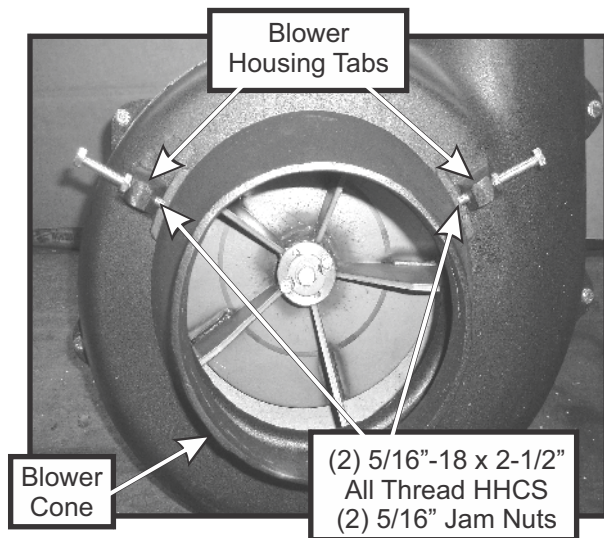

2-12 Impeller Blade

Removal/Replacement

Remove the blower cone from the blower housing located on the PTO assembly P#(A0623). With the blower cone removed, you will have access to the impeller blade P#(A0645). Refer to Figure 2-12.

To Remove: First remove the 3/8"-16 x 1-1/2" HHCS P#(K1211) (#1), taper lock bushing washer P#(K0278) (#3) and spacer bushing P#(S3242) (#4) from the taper lock bushing (#5). See Figure 2-9. Next remove the (2) 1/4"-20 x 1" HHCS (#2) and place them into the threaded holes of the taper-lock bushing P#(S4302) (#5). Gradually thread each bolt evenly into the taper-lock bushing, forcing the blade to break-away from the taper-lock bushing. If the impeller will not move, carefully hit the base of the impeller, between each vein, with a hammer, then try again.

To Replace: Place impeller blade over the engine shaft. Slide the taper-lock bushing (#5) on to the engine shaft and into the impeller blade, aligning the **non-threaded** holes of the taper-lock bushing to the threaded holes of the impeller blade. Fasten by using (2) 1/4"-20 x 1" HHCS (#2), (1) spacer bushing (#4) (1) taper lock bushing washer (#3), and (1) 3/8"-16 x 1-1/2" HHCS (#1). Torque to the proper specifications in the torque chart on the back of this manual. Next, rotate the impeller blade to ensure that the blade is clear of contact on all sides of the blower housing.

Figure 2-12

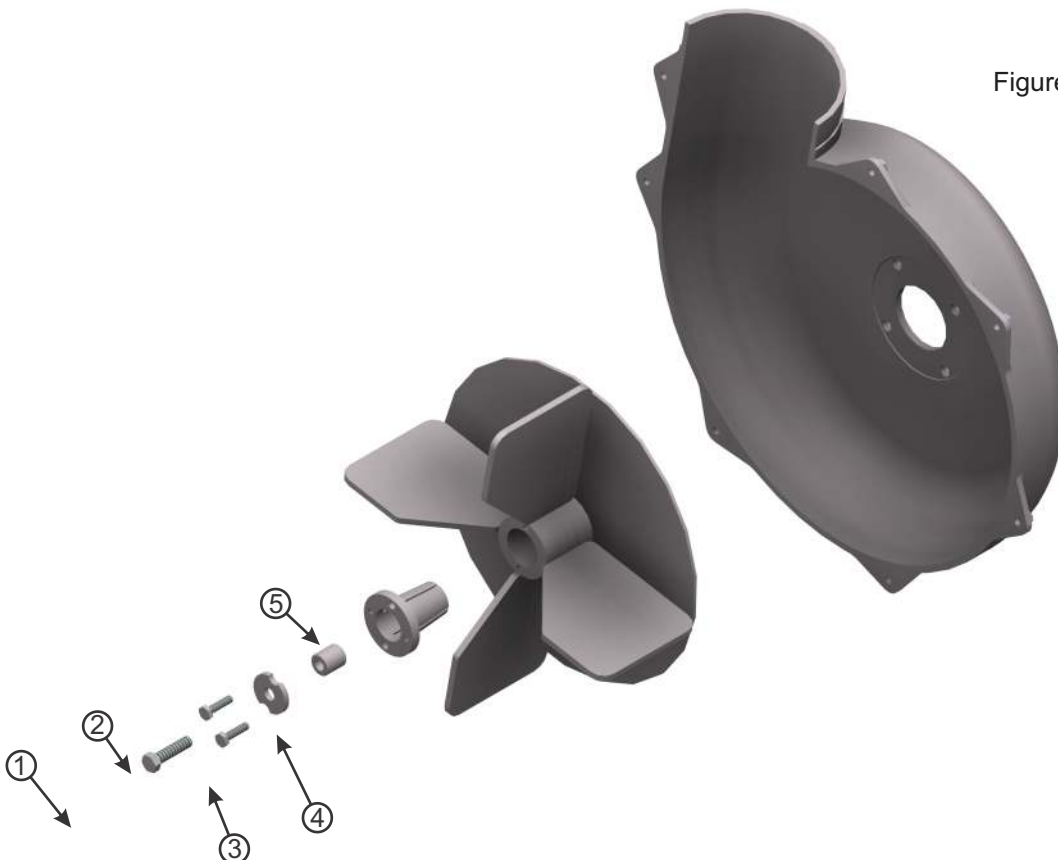

2-13 Length Of Hose Adjustment

The hoses in steps 2-14 and 2-15 must be cut to fit your machine. Follow steps 2-14 and 2-15. do not cut the hoses until you have tried to fit them on your machine. Remember that the hoses have to be long enough to adjust for the blower assembly's movement as well as allow for enough clamping surface between the inlet, blower assembly, and the deck boot.

2-14 Upper Hose Installation

Fasten the inlet to the plastic top by sliding the inlet from the inside of the top to the outside and lock into place. Slide a 2"-10" hose clamp P#(J1000) onto both ends of the 6" upper hose (Figure 2-15). Then slide one end of the 6" hose onto the inlet. Make sure there is about a two-inch overlap between the hose end and the container inlet. Proceed to slide the opposite end of the 6" hose onto the outlet of the blower assembly. See (Figure 2-15) for details. Make sure both ends of the hose are clearly attached to the inlet and the blower assembly inlet. Tighten the hose clamps.

2-15 Lower Hose To Blower Cone Installation

Slide a 2"-10" hose clamp P#(J1000) over both ends of the lower hose. Then proceed to slide the lower hose onto the blower cone. Tighten the hose clamp. The assembly should look like Figure 2-15.

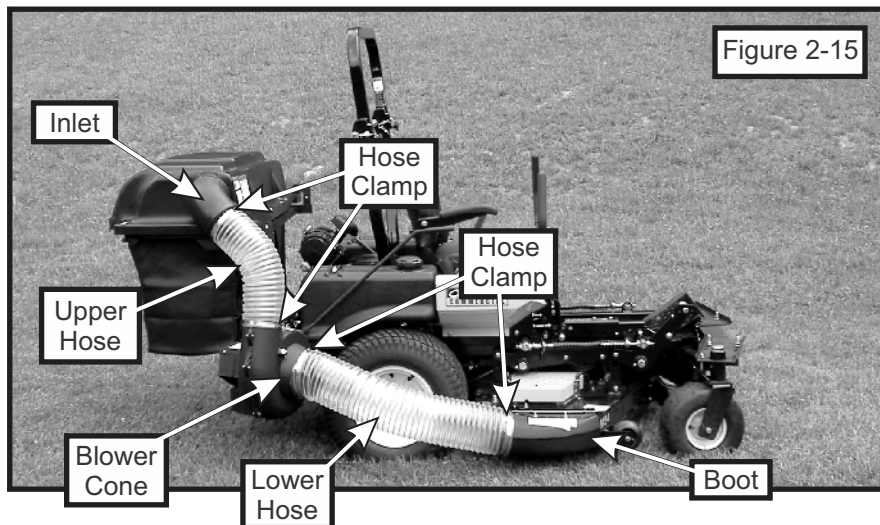

2-16 Lower Hose To Boot Installation

Take the unattached end of the lower hose and slide it over the circular end of the boot. Use the lower hose clamp to secure the hose to the boot (Figure 2-16). Tip: Before securing clamp rotate hose counter-clockwise (away from yourself) approximately 1" to add in retaining boot to mower deck.

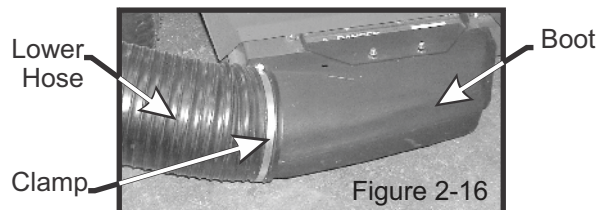

2-17 Front Weight Installation

Secure the left and right weight brackets P#(B0383) to the front frame of the mower, using (2) 3/8"-16 x 3-1/2" HHCS P#(K1200), (2) 3/8" flat washers P#(K0047), and (2) 3/8"-16 nyloc nuts P#(K1216) PER BRACKET. Lift the weight P#(B2220) into position and secure the weight to the weight bracket using (2) 1/2"-13 x 4-1/4" u-bolts P#(K0331), (2) 1/2" flat washers P#(K0055), and (4) 1/2"-13 nyloc nuts P#(K1427). Refer to Figure 2-17.

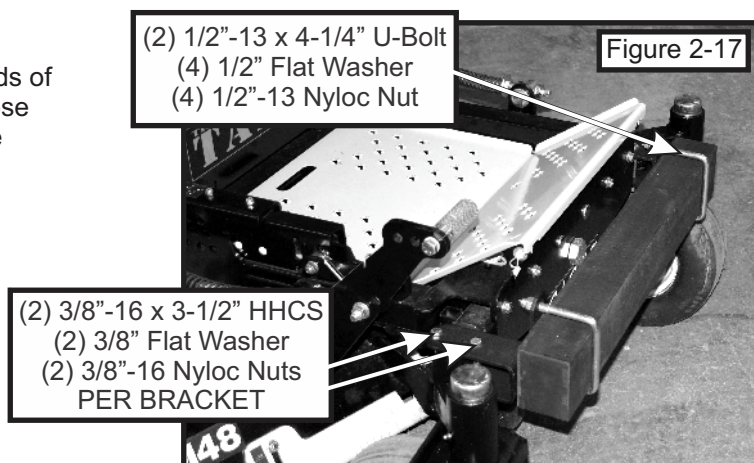

2-18 Installation/Removal Of Collection Bags

IMPORTANT!

To prevent bag wear, install (2) red plastic end caps P#(J0274), as shown in Figure 2-18a, on each bag ring before installing bags.

Figure 2-18a

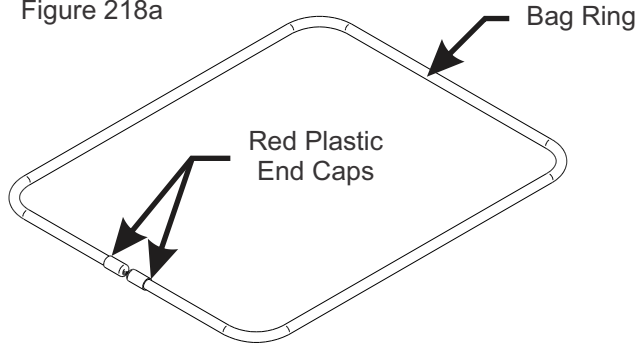

To install the bag onto the bag ring, place the seam openings of the bag onto the bag ring openings and turn the bag one full turn (360°) so the plastic end caps are located opposite to the opening in the bag (Figure 2-18b). Do this for each of three bags.

Figure 2-18b

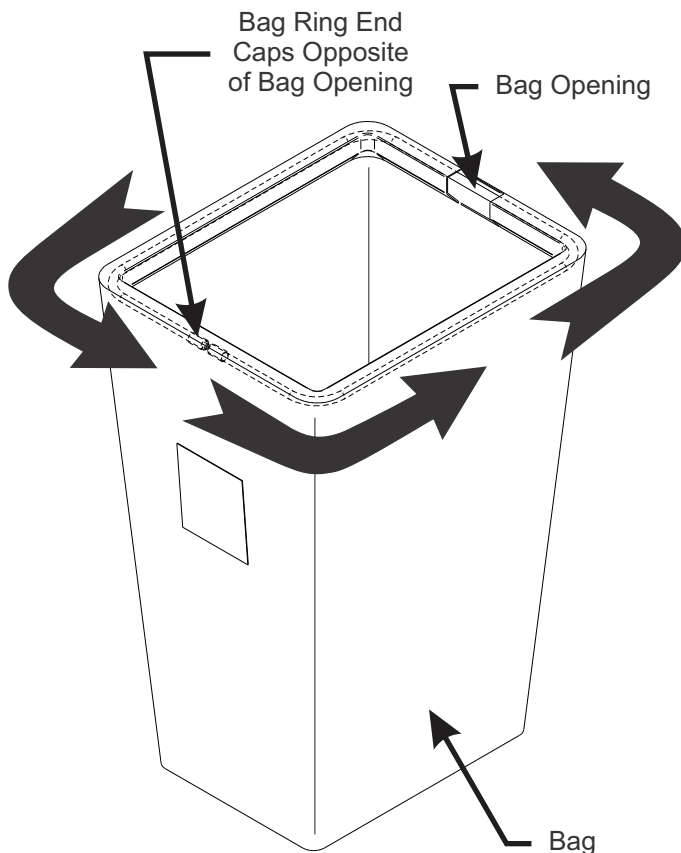

Install the completed assemblies onto the support frame and close the plastic top. Fasten both draw-latches to hold the plastic top closed (Figure 2-18c).

Figure 2-18c

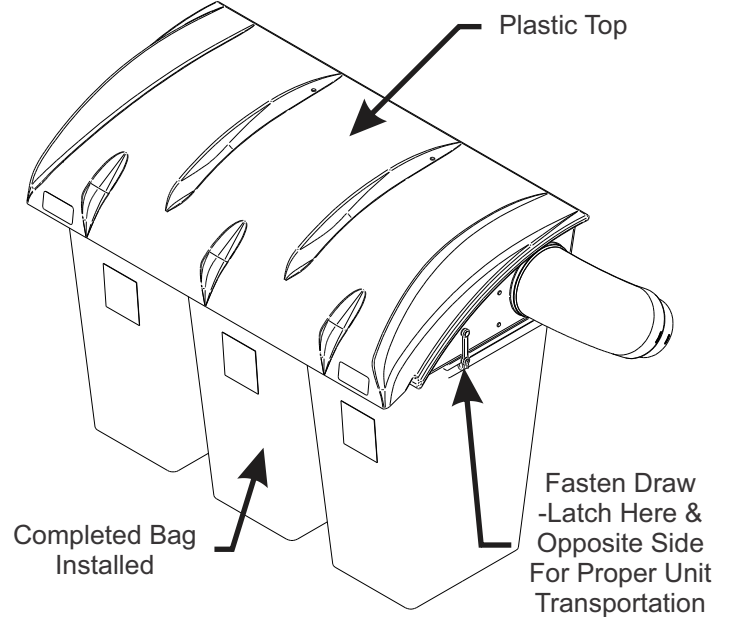

To empty the bag, first unlatch and lift top, next remove the bag and bag ring by sliding rearward, then grasp the loop on the bottom of the bag, and last turn it upside down to empty the collected debris (Figure 2-18d). Repeat for the other bags. Reinstall all bags, line with plastic bags if desired, close the plastic top and reattach the draw latches.

Figure 2-18d

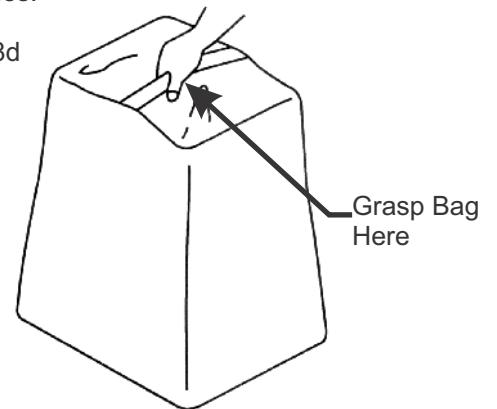

Plastic lawn and leaf bags, 33 gallon size, may be used inside the cloth bags. Be sure to leave enough plastic bag hanging over the frame so the plastic bags can be twist tied before emptying (Figure 2-18e).

Figure 2-18e

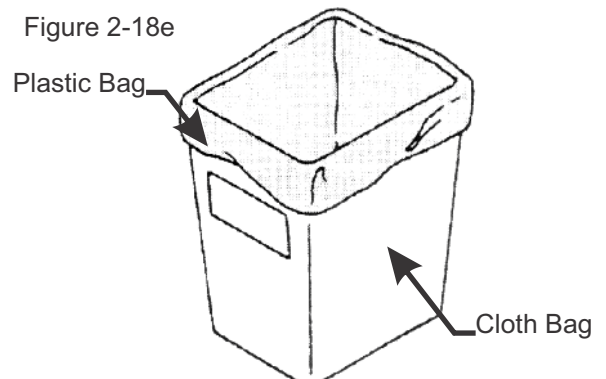

Exploded Parts View

A1158 Top Assembly

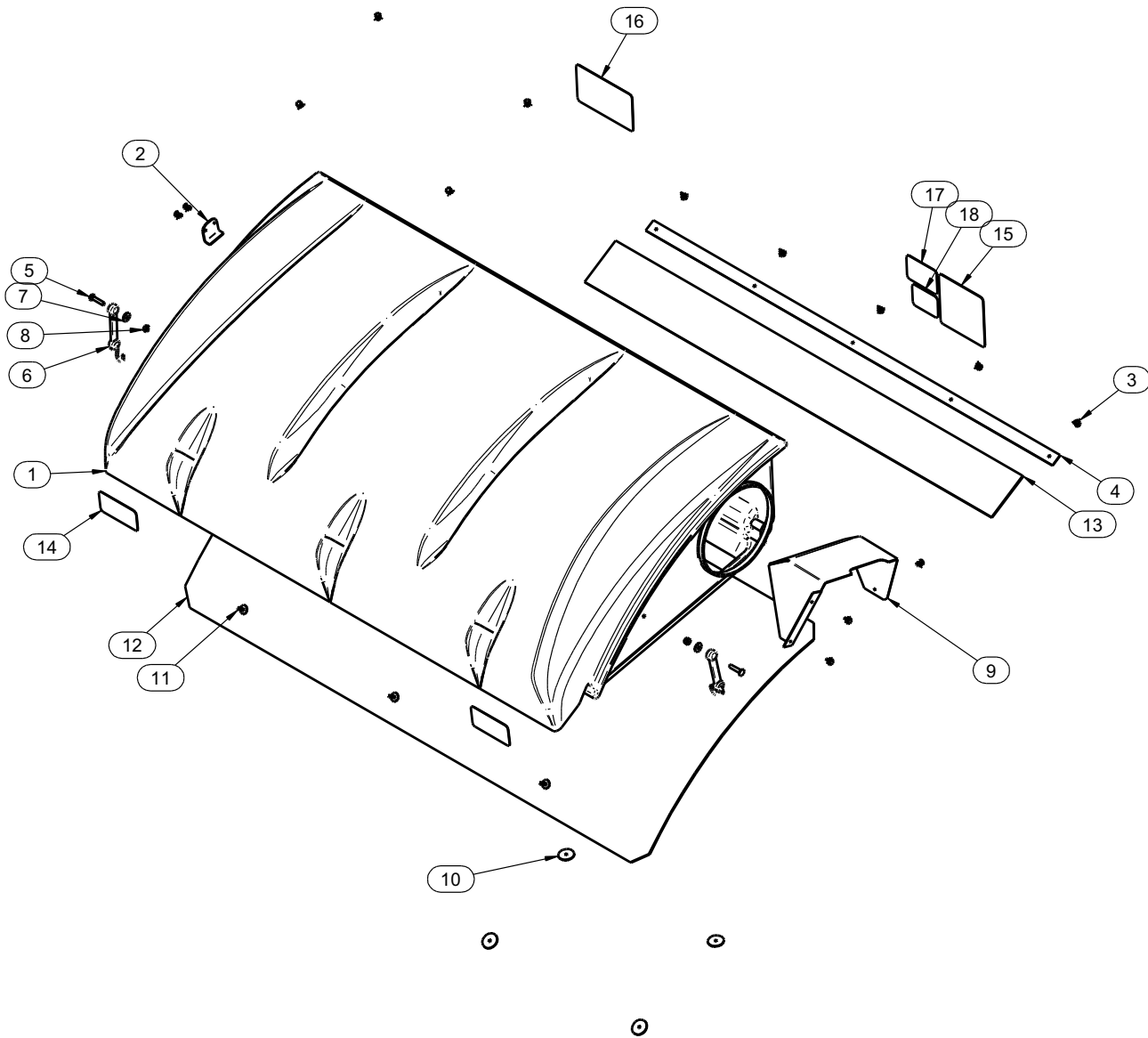

Item #	Doc #	Title	Qty
1	V0022	PRO 3 BAGGER TOP	1
2	B0676	Hinge Stop Pl.	1
3	K0114	BLACK PLASTIC RIVET	14
4	C0069	DUST GUARD BRACE	1
5	K1030	1/4"-20 x 1-1/4" CARRIAGE BOLT	2
6	J4009	SHORT RUBBER STRAP W/ S HOOK	2
7	K0037	1/4" FLAT WASHER .75 OD x .314 ID x .060 T	2
8	K1128	1/4"-20 NYLOC NUT	2
9	C0026	GRASS DEFLECTOR	1
10	K0062	3/16" x 1-1/2" FENDER WASHER, Z	4
11	K1265	BLACK PANEL RETAINER	3
12	V1120	Black Plastic Screen	1
13	V1118	DUST GUARD	1
14	R1057	2" x 4" Red Reflector Label	2
15	R1069	Warning - Turn Off Blower Label	1
16	R1065	Made In USA Label	1
17	R1054	Important Check Hoses	1
18	R1051	Warning - Use Hearing Protection	1

Exploded Parts View

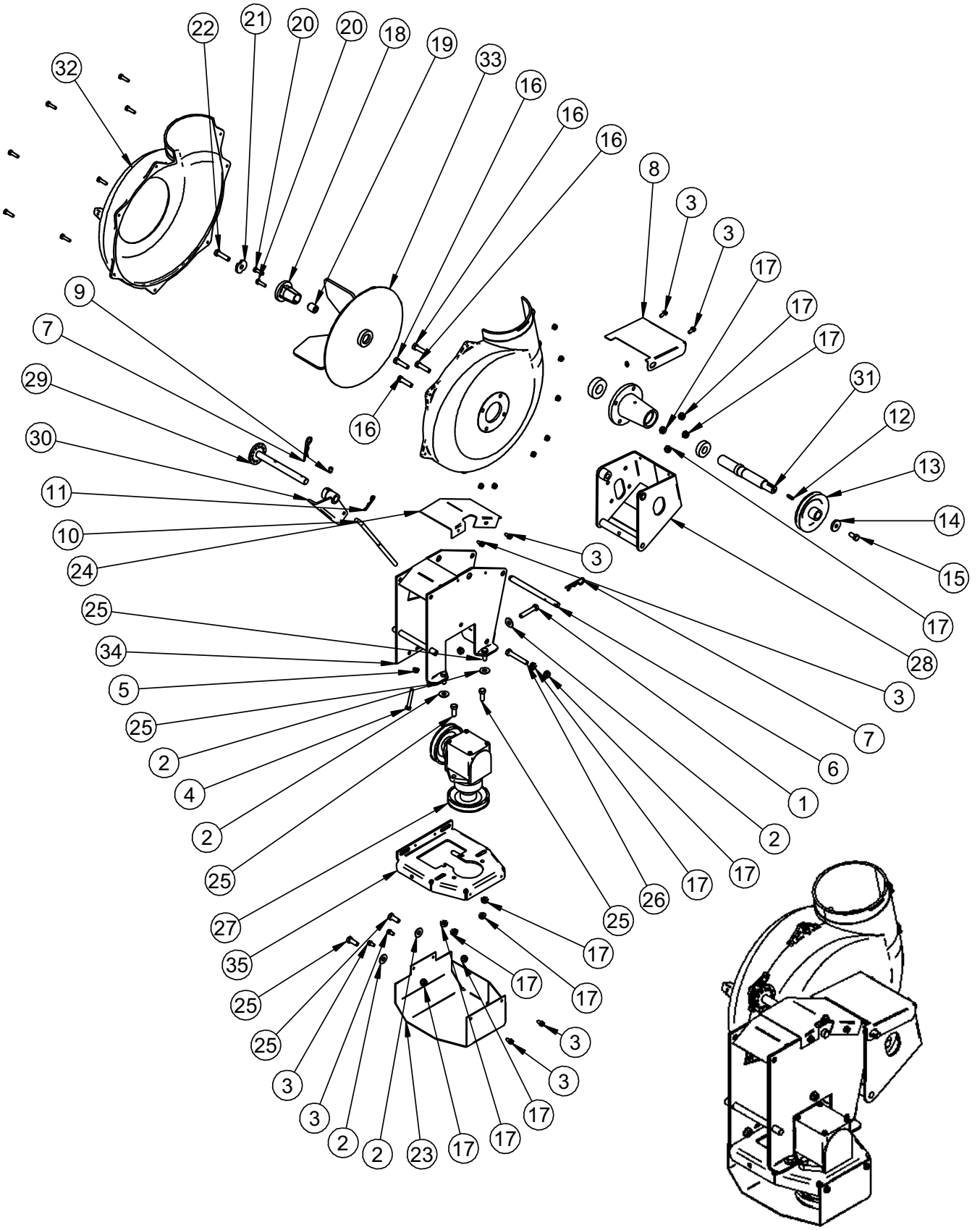

ISO VIEW

PTO Parts List

Item Number	Document Number	Title	Quantity
1	K0348	3/8"-16 x 2" ALL THREAD HHCS	1
2	K0047	3/8" FLAT WASHER 1.00 OD x .446 ID x .075 T	5
3	K0353	1/4"-20 x 1/2" HHSTS	8
4	K1159	5/16"-18 x 2" ALL THREAD HHCS	1
5	K1178	5/16"-18 FLANGE NUT	1
6	BI755	BLOWER PIVOT ROD	1
7	K0086	.125 OD x 2.50 HAIR PIN CLIP	2
8	B0121	BLOWER BELT GUARD	1
9	K0356	3/8"-16 TAPERED SET SCREW	1
10	K0326	BELT TENSION ROD 3/8"-16	1
11	K0130	.091 OD x 1.625 L HAIR PIN CLIP	1
12	J0254	3/16" SQ. x 3/4" LONG KEYWAY	1
13	M0228	BLOWER PULLEY	1
14	K1446	1.187 OD x .380 ID x .187 WASHER	1
15	K1190	3/8"-16 x 3/4" HHCS	1
16	K1193	3/8"-16 x 1-1/2" HHCS	4
17	K1215	3/8"-16 FLANGE NUT	12
18	S4302	TAPER-LOCK BUSHING	1
19	S3242	PLATED BUSHING	1
20	K1225	1/4"-20 X 1" HHCS GRADE 8	2
21	K0278	TAPER-LOCK BUSHING WASHER	1
22	K1211	3/8"-16 x 1-1/2" HHCS GRADE 8	1
23	B0269	GEAR BOX PULLEY GUARD	1
24	B0270	PTO ARM GUARD	1
25	K1191	3/8"-16 x 1" HHCS	6
26	K1197	3/8"-16 X 2 1/2" HHCS	1
27	A0429	GEAR BOX ASSEMBLY	1
28	A0144	BLOWER MOUNT BRACKET ASSEMBLY	1
29	A0604	PTO HANDLE MOUNT ASSY	1
30	A0422	CAM BRACKET ASSEMBLY	1
31	A0306	PTO SHAFT ASSEMBLY	1
32	E4004A	BLOWER HSG. ASSY.	1
33	A0645	SMALL 4-BLADE IMPELLER	1
34	A0622	PTO ARM ASSY.	1
35	A0624	BASE PLATE ASSY.	1

MODEL#: 21131205

MOWER NAME: CUB CADET

MOWER MODEL: TANK W/ 23HP KW

MOWER DECK SIZE: 48", 54", & 60"

VAC NAME: 12 CUBIC FOOT PRO BAGGER

PTO DRIVEN

A1787 UNIT ASSEMBLY



FOR YEAR: 2010

REVISED:

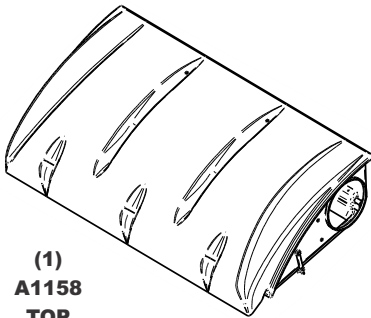

(1)
**A1158
TOP
ASSY.**



(1)
**V0025
6" & 7"
PLASTIC
INLET**



(1)
**F0004
7" x 35"
LOWER
HOSE**



(1)
**F0001
6" x 21"
UPPER
HOSE**



(4)
**J1000
2" - 10"
HOSE
CLAMPS**

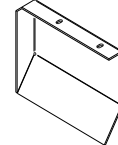

(1)
**C0058
EXHAUST
DEFLECTOR**



(1)
**HB0425
HARDWARE
BAG**

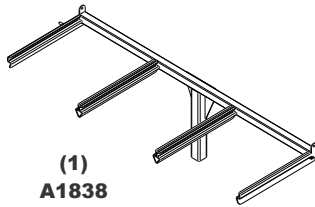

(1)
**A1838
UPPER FRAME
ASSEMBLY**

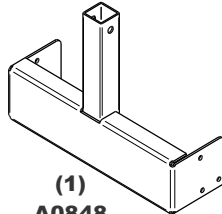

(1)
**A0848
LWR. MNT
ASSY.**

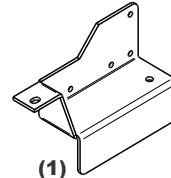

(1)
**B0395
LT. LWR.
MOUNT PL.**

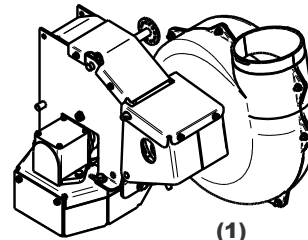

(1)
**A0623
PTO
ASSEMBLY**



(1)
**HB0426
ENGINE
PULLEY
HARDWARE
BAG**

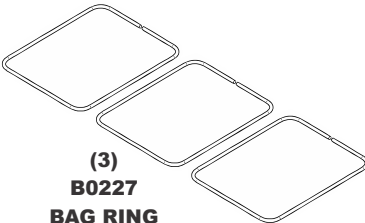

(3)
**B0227
BAG RING**

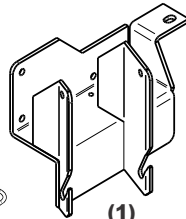

(1)
**A0846
PTO MOUNT
PLATE ASSY.**

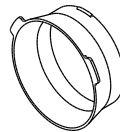

(1)
**E6004
7" BLOWER
CONE**

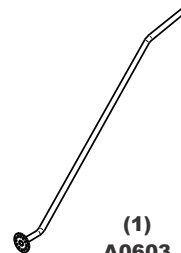

(1)
**A0603
PTO HANDLE
ASSY.**

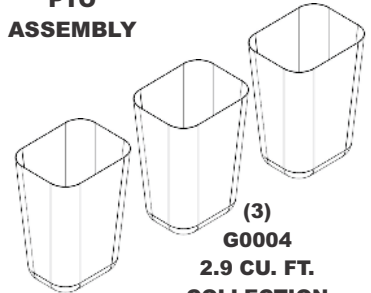

(3)
**G0004
2.9 CU. FT.
COLLECTION
BAGS**

A1784 - WEIGHT KIT

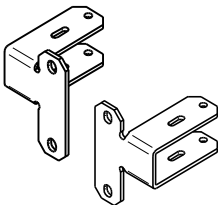

(1 LEFT)
(1 RIGHT)
**B0383
WEIGHT
BKRT.**



(1)
**HB0421
HARDWARE
BAG**

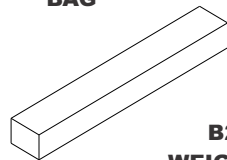

(1)
**B2220
WEIGHT BAR**

A0690 - BOOT KIT



(1)
**HB0078
HARDWARE
BAG**

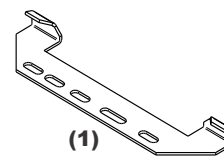

(1)
**B2555
BOOT
PLATE**



(1)
**B4331
BOOT ROD**

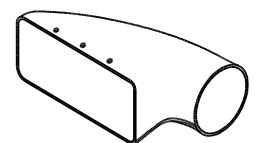

(1)
**E1031
BOOT**

SECTION III

OPERATING INSTRUCTIONS

3-1 General Safety

Only qualified people familiar with this operator's manual and the mower's operator's manual should operate this machine.

3-2 Operation And Tips On Mowing

- A. Perform BEFORE EACH USE the maintenance list in paragraph 4-1.
- B. Start mower.
- C. With the mower at high idle speed, engage the mower deck.
- D. While seated in the operator's seat, rotate the engagement handle of the collection system away from the mower. Continue to rotate the handle until it stops in an over center position. With the blower engaged, you can proceed to operate the control levers of the mower.

NOTE: If the collection system does not appear to be collecting the grass clippings, disengage the deck and blower, then, engage the parking brake and turn the mower off. Proceed to section 3-3, and review the section 2-3 and 2-4, in this manual.

To obtain the maximum effectiveness from your collection system the tips listed below should be followed:

- * Watch your speed- Normal conditions will allow a speed of up to approximately 5 mph, but thick, heavy damp conditions will require reduced ground speed.
- * Mow with sharp blades- A sharp blade cuts cleaner.
- * Wet grass and leaves will decrease effectiveness and will increase horsepower requirements.
- * Mow at higher cutting heights- Remove and mulch no more than 2" of grass length with each mowing. (Experts recommend not cutting off more than 1/3 of the grass blade length at any given time.)
- * Mow twice, at different height settings, (high, then low), if grass is extra tall.
- * Remember that horsepower requirements will vary with the mowing conditions such as type and height of turf grass, moisture content, amount of leaves, whether the terrain is flat or hilly, etc.

3-3 Disengagement Of The Blower

- A. To disengage the blower, rotate the engagement handle towards the mower.

WARNING: The blower will continue to spin. DO NOT TOUCH the blower, pulleys, or the belt until the tractor is turned off. DO NOT adjust the belt tension until the mower is turned off. Refer to section 2-5 of the manual.

3-4 Unloading The Collection System

NOTE: To determine when the collection bags are full, follow the following steps:

- A. Stop the forward movement of the mower.
- B. Disengage the mower deck.
- C. Disengage the blower.
- D. Engage the parking brake.
- E. Once the parking brake has been engaged, then and only then, walk behind the mower and check the collection bags by lifting the plastic hood. Load in bags should not exceed the height of the installed bag.
- F. To release bags from frame, lift bag ring from tab on bagger frame, slide bag out and turn bags over to deposit clippings.
- G. Follow steps on page 34 to re-attach bags back to the bagger.

NOTE: Do not allow collection bags to become over-filled as potential damage may occur to your equipment. Also, be sure to clean the hood screen as needed.

SECTION IV

MAINTENANCE

4-1 Maintenance Checklist

NOTE: REMOVE PTO ASSEMBLY BEFORE RAISING DECK FOR MAINTENANCE.

Before each use:

1. Check blades and spindles to be sure that no foreign objects, such as wire or steel strapping bands, are wrapped around them.
2. Inspect blades for wear. Replace if necessary. If it is necessary to sharpen the blades, remove the blades from the spindles before sharpening. DO NOT sharpen blades while still attached to the mower.

3. Make sure all shields are in place and in good condition. Repair or replace any missing or damaged shields.
4. Perform lubrication per paragraph 4-2.
5. Listen for abnormal sounds, which might indicate loose parts, damaged bearings, or other damage. Correct any deficiency before continuing operation.
6. With the engine off, engage the blower assembly. Check the belt tension and inspect the pulley belt for cracks or tears.
7. Check for wear or deterioration of the upper or lower hoses. If there are any portions of the hose that have been torn or worn through, replace with genuine PECO parts.

After Each Use:

1. Clean all debris from machine especially from the container, underneath the belt shields, and safety decals. Replace any missing or illegible decals.
2. Inspect the unit for worn or damaged components. Repair or replace before the next use. Any replacement component installed during repair shall include the component's current safety decal specified by the manufacturers to be affixed to the component.
3. Check belt for proper tension.

THE SERIAL NUMBER PLATE IS LOCATED ON THE TOP ASSEMBLY P#(A0551)

PECO	
OUTDOOR POWER EQUIPMENT	
Model Number	<input style="width: 95%;" type="text"/>
Serial Number	<input style="width: 95%;" type="text"/>
Arden, North Carolina 28704	

WRITE THE MODEL AND SERIAL NUMBER IN THE BOX ABOVE FOR FUTURE REFERENCE.

4-2 Lubrication

NOTE: Use only white lithium based grease for lubrication of the shaft on the blower assembly.

1. On initial use: Grease the fitting on the blower shaft.
2. Every 25 hours of use: Re-grease the grease fitting.
3. Every 200 hours of use: Check oil levels in gear box. Oil in gear box should cover the gears. If not, fill using an EP90 weight oil. 6oz. will fill the gear box from empty.

SECTION V PARTS AND SERVICE

5-1 Parts And Service Information

PECO collection system owners should record the name and telephone number of their Service Center. Your Service Center will be happy to supply replacement parts, accessories, and do any service or repairs to your collection system. If for any reason your Service Center is unable to service your collection system or supply replacement parts, contact PECO and include the following information on the chart below.

Unit Model Number: _____
Unit Engine Size: _____
Unit Serial Number: _____
Date of purchase: ____/____/_____
Dealer/Distributor Name: _____
Dealer's/Distributor's: _____ **State:** _____ **Zip:** _____
Phone Number: _____

Address: PECO Inc.
100 Airport Road
Arden, NC 28704

Phone #: (828) 684-1234 or Toll Free: (800) 438-5823

Email: peco@lawnvac.com

SAFETY DECALS

To promote safe operation, PECO supplies safety decals on all products manufactured. Damage can occur to safety decals either through shipment, use or reconditioning. Contact your local Service Center for replacement decals.



Part #: R1054
Important Label



Part #: R1069
Warning: Turn Off Blower Label



Part #: R1057
Red Reflector Label



Part #: R4015
Danger: Rotating Blade Label

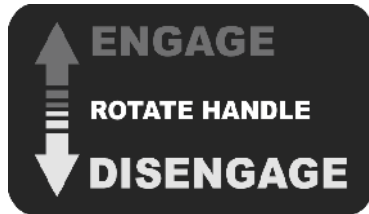

Part #: R1083
Engage/Disengage Label



Part #: R1065
Made In America Label



Part #: R4008
Caution: Rotating Blades Label

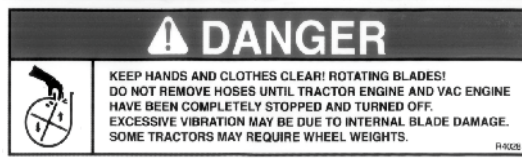

Part #: R4028
Danger Keep Hands & Clothes Clear Label



Part #: R1051
Warning: Hearing Protection Label



Part #: R1052
Small Warning: Turn Off Blower Label



Part #: R4037
Warning: Hot Surface Label



Part #: R1090
Pro Bagger Logo Label

TORQUE SPECIFICATIONS

Proper torque for American fasteners used on Peco equipment.
Recommended Torque in Foot Pounds (Newton Meters).*

AMERICAN Bolt Head Markings

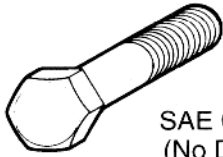

SAE Grade 2
(No Dashes)

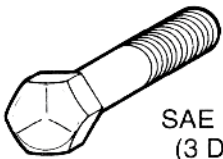

SAE Grade 5
(3 Dashes)

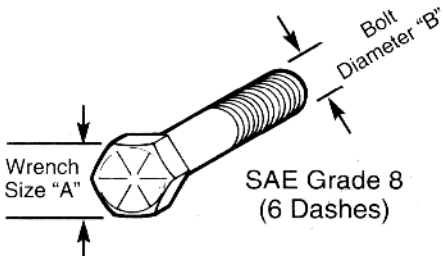

SAE Grade 8
(6 Dashes)

WRENCH SIZE (IN.) "A"	BOLT DIAMETER (IN.) "B" AND THREAD SIZE	SAE GRADE 2	SAE GRADE 5	SAE GRADE 8
7/16	1/4 - 20 UNC	6 (7)	8 (11)	12 (16)
7/16	1/4 - 28 UNF	6 (8)	10 (13)	14 (18)
1/2	5/16 - 18 UNC	11 (15)	17 (23)	25 (33)
1/2	5/16 - 24 UNF	13 (17)	19 (26)	27 (37)
9/16	3/8 - 16 UNC	20 (27)	31 (42)	44 (60)
9/16	3/8 - 24 UNF	23 (31)	35 (47)	49 (66)
5/8	7/16 - 14 UNC	32 (43)	49 (66)	70 (95)
5/8	7/16 - 20 UNF	36 (49)	55 (75)	78 (106)
3/4	1/2 - 13 UNC	49 (66)	76 (103)	106 (144)
3/4	1/2 - 20 UNF	55 (75)	85 (115)	120 (163)
7/8	9/16 - 12 UNC	70 (95)	109 (148)	153 (207)
7/8	9/16 - 18 UNF	79 (107)	122 (165)	172 (233)
15/16	5/8 - 11 UNC	97 (131)	150 (203)	212 (287)
15/16	5/8 - 18 UNF	110 (149)	170 (230)	240 (325)
1-1/8	3/4 - 10 UNC	144 (195)	266 (360)	376 (509)
1-1/8	3/4 - 16 UNF	192 (260)	297 (402)	420 (569)
1-5/16	7/8 - 9 UNC	166 (225)	430 (583)	606 (821)
1-5/16	7/8 - 14 UNF	184 (249)	474 (642)	668 (905)
1-1/2	1 - 8 UNC	250 (339)	644 (873)	909 (1232)
1-1/2	1 - 12 UNF	274 (371)	705 (955)	995 (1348)
1-1/2	1 - 14 UNF	280 (379)	721 (977)	1019 (1381)
1-11/16	1-1/8 - 7 UNC	354 (480)	795 (1077)	1288(1745)
1-11/16	1-1/8 - 12 UNF	397 (538)	890 (1206)	1444 (1957)
1-7/8	1-1/4 - 7 UNC	500 (678)	1120 (1518)	1817 (2462)
1-7/8	1-1/4 - 12 UNF	553 (749)	1241 (1682)	2013 (2728)
2-1/16	1-3/8 - 6 UNC	655 (887)	1470 (1992)	2382 (3228)
2-1/16	1-3/8 - 12 UNF	746 (1011)	1672 (2266)	2712 (3675)
2-1/4	1-1/2 - 6 UNC	870 (1179)	1950 (2642)	3161 (4283)
2-1/4	1-1/2 - 12 UNF	979 (1327)	2194 (2973)	3557 (4820)

METRIC

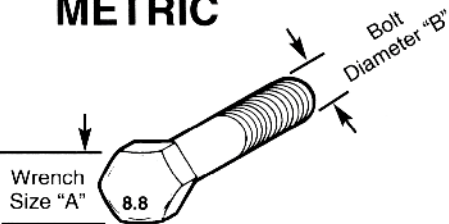

Numbers appearing on bolt heads indicate ASTM class.

Proper torque for metric fasteners used on Peco equipment.
Recommended torque in foot pounds (newton Meters).*

WRENCH SIZE (mm) "A"	BOLT DIA. (mm) "B"	ASTM 4.6	ASTM 8.8	ASTM 9.8	ASTM 10.9
8	5	1.8 (2.4)		5.1 (6.9)	6.5 (8.8)
10	6	3 (4)		8.7 (12)	11.1 (15)
13	8	7.3 (10)		21.1 (29)	27 (37)
16	10	14.5 (20)		42 (57)	53 (72)
18	12	25 (34)	74 (100)	73 (99)	93 (126)
21	14	40 (54)	118 (160)	116 (157)	148 (201)
24	16	62 (84)	167 (226)	181 (245)	230 (312)
30	20	122 (165)	325 (440)		449 (608)
33	22		443 (600)		611 (828)
36	24	211 (286)	563 (763)		778 (1054)
41	27		821 (1112)		1138 (1542)
46	30	418 (566)	1119 (1516)		1547 (2096)

*Use 75% of the specified torque value for plated fasteners. Use 85% of the specified torque values for lubricated fasteners.



**P.O. BOX 1197
ARDEN, NORTH CAROLINA 28704
(800) 438-5823 OR (828) 684-1234 FAX: (828) 684-0858
EMAIL: peco@lawnvac.com
WEBSITE: www.lawnvac.com**