



# Residential PTO - GRASS COLLECTION SYSTEM

COUNTRY  
**CLIPPER**  
ZERO TURN MOWER

## Edge XLT Series

48" & 52" DECKS

MODEL YEAR:

**2018-NEWER**



**Model# 49120908**  
**(629JH-001A)**

## OPERATOR'S MANUAL

**ASSEMBLY • OPERATION • MAINTENANCE**

# GRASS COLLECTION SYSTEM

## TABLE OF CONTENTS

SECTION	PAGE	SECTION	PAGE
Safety	2	Boot Kit Installation	15
Safety Alert Symbols	3	Length of Hose Adjustment	16
Warranty	4	Upper Hose Installation	16
I INTRODUCTION AND DESCRIPTION	5	Lower Hose to Blower Cone Installation	16
Introduction	5	Lower Hose to Boot Installation	16
Description	5	Impeller Blade Removal/Replacement	17
II INSTALLATION FOR USE	5	Weight Kit Installation	18
Preparation Of Mower	6	Exploded Views & Parts List	19-21
Rear Frame Assy & Installation	7	Overall Parts List	22
PTO Mount Assy Installation	8	Safety Decals	23
Lower Mount Tube Installation	9	III OPERATING INSTRUCTIONS	24
Upper Frame Assy Installation	9	General Safety	24
PTO Drive Assy Installation	10	Operation & Tips On Mowing	24
Blower Cone Installation	10	Disengagement Of The PTO Assembly	24
Belt Installation & Adjustment	11	Unloading The Collection System	24
Top Assy To Upper Frame Assy Installation	12	IV MAINTENANCE	24-25
Inlet Installation	12	Maintenance Checklist	25
Hinge Kit Assy Installation	13	Lubrication	25
Even Bag Fill Adjustment	13	V PARTS AND SERVICE	25
Bag Assembly	14	Parts And Service Information	25
Bag Assembly Installation	14	Torque Specifications	26
		Troubleshooting	27

## SAFETY

1. Read the operator's manual carefully and familiarize yourself with the proper use of your attachment. Do not allow anyone who is not acquainted with the Safety Instructions to use your attachment.
2. Know the controls and how to stop them quickly. **READ THE OPERATOR'S MANUAL!**
3. Do not allow children to operate the machine. Do not allow adults to operate it without proper instruction.
4. Be especially watchful of children and pets entering into the area while operating.
5. Keep your eyes and mind on your machine while mowing or operating your attachment. Don't let others distract you.
6. Do not attempt to operate your machine when not in the driver's seat.
7. Always shut off blades and engine when emptying the container.
8. Stop machine, shut off deck attachment, set parking brake, shut off engine and remove ignition key before removing clogs, removing or replacing hose, boot, blower cone, or performing any maintenance.
9. Mow across the face of slopes (not more than 10 degrees); never up and down the face.
10. It is recommended that the container be emptied when half full while operating on slopes. Start mowing on slopes when the container is empty.
11. Inspect your lawn and remove any foreign objects before mowing. Never deliberately run the mower across any foreign object.
12. Wear hearing protection.
13. Wear eye protection to prevent debris from getting into your eyes.

# SAFETY

**WARNING!** NEVER operate the mower unless the discharge guard and either the deflector assembly or the vacuum collector adapter are fastened securely in place.

**WARNING!** Do not work around the mower deck boot or the blower area until you are certain that the mower blades and the blower impeller have stopped rotating.

**WARNING!** To avoid serious injury, perform maintenance on the vacuum collector; **ONLY AFTER STOPPING THE MOWER'S ENGINE AND WAITING FOR ALL MOVING PARTS TO COME TO A COMPLETE STOP.** Set the parking brake. Always remove the ignition key before beginning maintenance.

**WARNING!** For your own personal safety, **ALWAYS mow ACROSS the face of slopes and NEVER UP and DOWN the face. NEVER attempt to mow excessively steep slopes, and use caution when turning on any slope.**

## Safety Alert Symbol



This Safety Alert Symbol means: **“ATTENTION! BECOME ALERT! YOUR SAFETY IS INVOLVED!”**

This symbol is used to call attention to safety precautions that should be followed by the operator to avoid accidents. When you see this symbol, carefully read the message that follows and heed its advice. Failure to comply with safety precautions could result in death or serious bodily injury.

## Safety Signs

The signal words **DANGER**, **WARNING**, and **CAUTION** are used on the equipment safety signs. These words are intended to alert the viewer to the existence and the degree of hazard seriousness.



White letters on **RED**

This signal word indicates a potentially hazardous situation which, if not avoided, will result in death or serious injury.



Black letters on **ORANGE**

This signal word indicates a potentially hazardous situation which, if not avoided, could result in death or serious injury.

It may also be used to alert against unsafe practices.



Black letters on **YELLOW**

This signal word indicates a potentially hazardous situation which, if not avoided, will result in minor or moderate injury.

It may also be used to alert against unsafe practices.

# PECO LIMITED WARRANTY FOR NEW PRODUCTS

## A. WHAT IS UNDER WARRANTY?

PECO extends the following warranties to the original purchaser of each new PECO consumer product subject to the following limitations.

- 1. PRODUCT WARRANTY:** Any part of any consumer product, which is defective in material or workmanship as delivered to the purchaser will be repaired or replaced, as PECO elects, without charge for parts or labor, if the defect appears within 12 months from the date of delivery of the product to the original purchaser. ALL DEFECTIVE PARTS MUST BE RETURNED TO PECO FOR INSPECTION TO DETERMINE VALIDITY OF WARRANTY CLAIMS. Freight and mailing will be borne by the customer.
- 2. PARTS REPLACED DURING WARRANTY:** Any new PECO part which is furnished in performance of this warranty and is defective in material or workmanship as delivered to the purchaser will be repaired or replaced, before the expiration of the original warranty period, whichever is later.
- 3. COMMERCIAL USE:** Products put to personal use around a single household or residence is considered 'Residential'; Products put to any business use (agricultural, commercial, or industrial) or used at multiple locations is considered 'Commercial.' Products designated as 'Commercial' are warrantied for 12 months from the date of delivery of the product to the original purchaser when used for in commercial applications. Products designated as 'Residential' are warrantied for 90 days from the date of delivery of the product to the original purchaser when in commercial applications.

## B. SECURING WARRANTY ADJUSTMENTS

Call PECO for Return Authorization. Damaged or broken parts other than engines or batteries, must be returned to New PECO, Inc. at 10 Walden Drive, Arden, NC 28704 before any warranty adjustment can be authorized. At the time of requesting warranty adjustment, the purchaser must present evidence of the date of delivery of the product. The purchaser shall pay any charge for the product to and from Arden, NC.

## C. ITEMS NOT COVERED BY PECO WARRANTY

Engines and batteries attached to PECO products are covered under a separate warranty by the respective manufacturer.

## D. UNAPPROVED ALTERATION OR MODIFICATION

All obligations of New PECO, Inc. under this warranty shall be terminated if products are altered or modified in ways not approved by New PECO, Inc.

## E. ACCIDENTS AND NORMAL MAINTENANCE

The warranty covers only defective material and workmanship. It does not cover depreciation or damage caused by normal wear, accident, improper use or abuse of products. The cost of normal maintenance and normal replacement of service items such as belts, cutting blades, hoses, etc., which are not defective shall be paid for by the purchaser.

## F. NO REPRESENTATIONS ADDITIONAL WARRANTIES, DISCLAIMER

Neither New PECO, Inc. nor any company affiliated with it makes any warranties, representations or promises as to the quality of performance of its products other than those set forth herein. Except as described above, New PECO, Inc. makes no other warranties AND SPECIFICALLY DISCLAIMS ANY AND ALL IMPLIED WARRANTIES OF FITNESS AND MERCHANTABILITY.

## G. PRODUCTS USED FOR RENTAL OR LEASE PURPOSES ARE WARRANTIED FOR 45 DAYS FROM DATE OF ORIGINAL SALE ONLY

## H. REMEDIED EXCLUSIVE

The only remedies the purchaser has in connection with the breach or performance of any warranty on New PECO, Inc. consumer products are set forth above. In no event will PECO be liable for special incidental or consequential damages.

### 1. NO SERVICE CENTER WARRANTY

The selling Service Center makes no warranty on his own on any item warrantied by New PECO, Inc. unless he delivers to purchaser a separate written warranty certificate specifically warranting the item. The dealer has no authority to make any representation or promise on behalf of PECO or to modify the terms of this warranty in any way.

# Section I - INTRODUCTION AND DESCRIPTION

## Introduction

We are pleased to have you as a PECO customer. Your collection system has been designed to give you a low maintenance, simple, and effective way to collect the grass clippings from your mower. The manuals are provided to give you the necessary instructions to properly mount, operate and maintain the collection system on your mower. Please read this manual thoroughly. Understand what each control is for and how to use it. Observe all safety decal precautions on the machine and noted throughout the manual.

**NOTE:** All references made to right, left, front, rear, top or bottom are as viewed from the normal operator's position on the mower.

## Description

The grass collection system is designed for turf maintenance where there is a need to collect the grass clippings as the mower cuts the turf. It is also used for picking up leaves in pre-season and post-season clean-up. The blower, mounted on the right side of the unit, uses a belt and gearbox system from the engine PTO shaft. Drive train protection comes through belt slippage. The blower draws grass clippings from the discharge area of the cutting deck back to the collection bags at the rear portion of the mower frame. The operator can engage the blower with a push of the over-center linkage on the right side of the unit. Once the bags are full with clippings, they can be easily released for dumping.



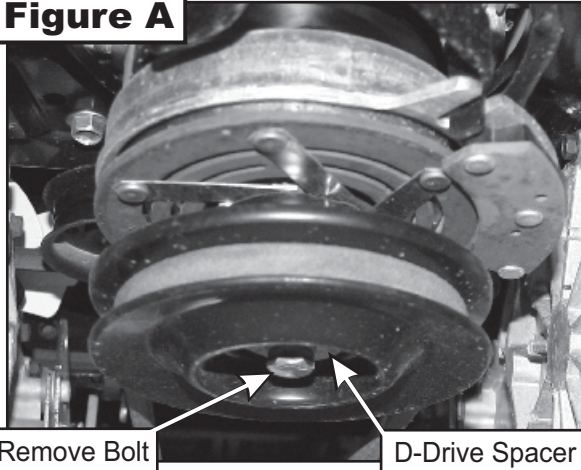
## Section II - INSTALLATION FOR USE

### Preparation Of Mower

**NOTE:** The mower deck PTO belt must be removed from the electric clutch before continuing with the installation. Refer to your mower's owner's manual for instructions on PTO belt removal.

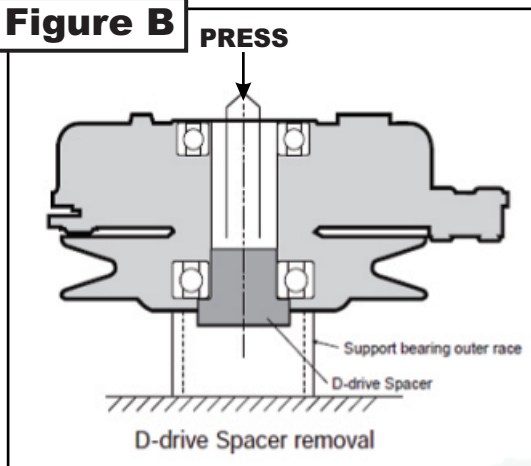
From the underside of the engine, disconnect the wiring harness attached to the electric clutch. Remove the bolt and electric clutch from the mower. Refer to Figure A.

**Figure A**

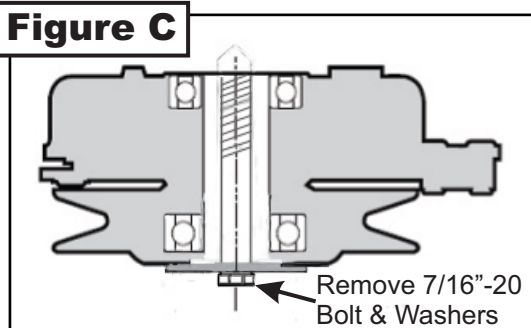


Upon removal of clutch determine if your mower is equipped with a D-drive spacer. If so, then proceed to Figure B. If your mower is equipped with bolt, fender and lock washer without D-drive spacer proceed to Figure C. Remove the D-drive spacer using an arbor press or equivalent. On removal, adjacent bearing OUTER race must be supported or bearing damage may occur. Refer to Figure B.

**Figure B**

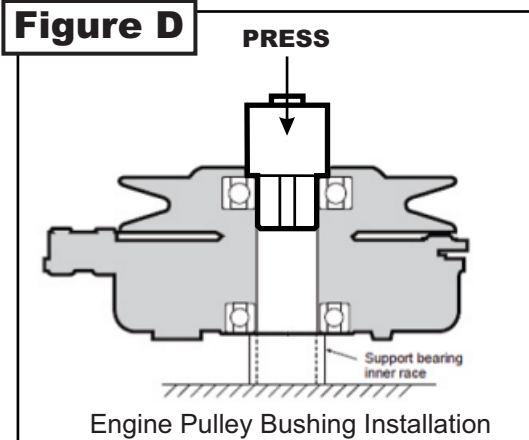


**Figure C**



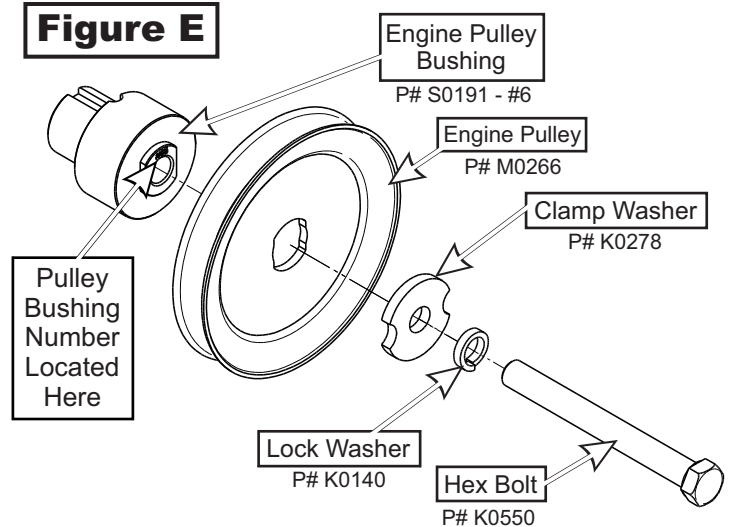
The engine pulley assembly must be installed using an arbor press or equivalent. During installation, opposite bearing inner race must be supported or bearing damage may occur. Refer to Figure D.

**Figure D**



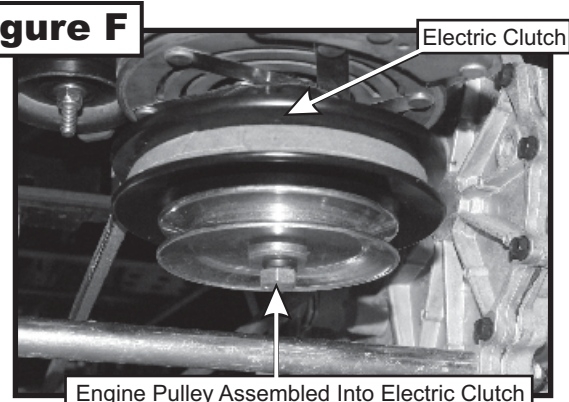
Once the Engine Pulley Bushing is installed, reattach the clutch assembly & deck PTO belt to the mower and then review Figure E.

**Figure E**



To assemble and fasten the Engine Pulley, align the Engine Pulley Bushing to the mower's clutch pulley and fasten using (1) Clamp Washer, (1) Lock Washer, and (1) Hex Bolt. Torque the bolt to 55 ft./lbs. The added pulley will power the collection system and should resemble Figure F when installed.

**Figure F**



## Rear Frame Assembly & Installation

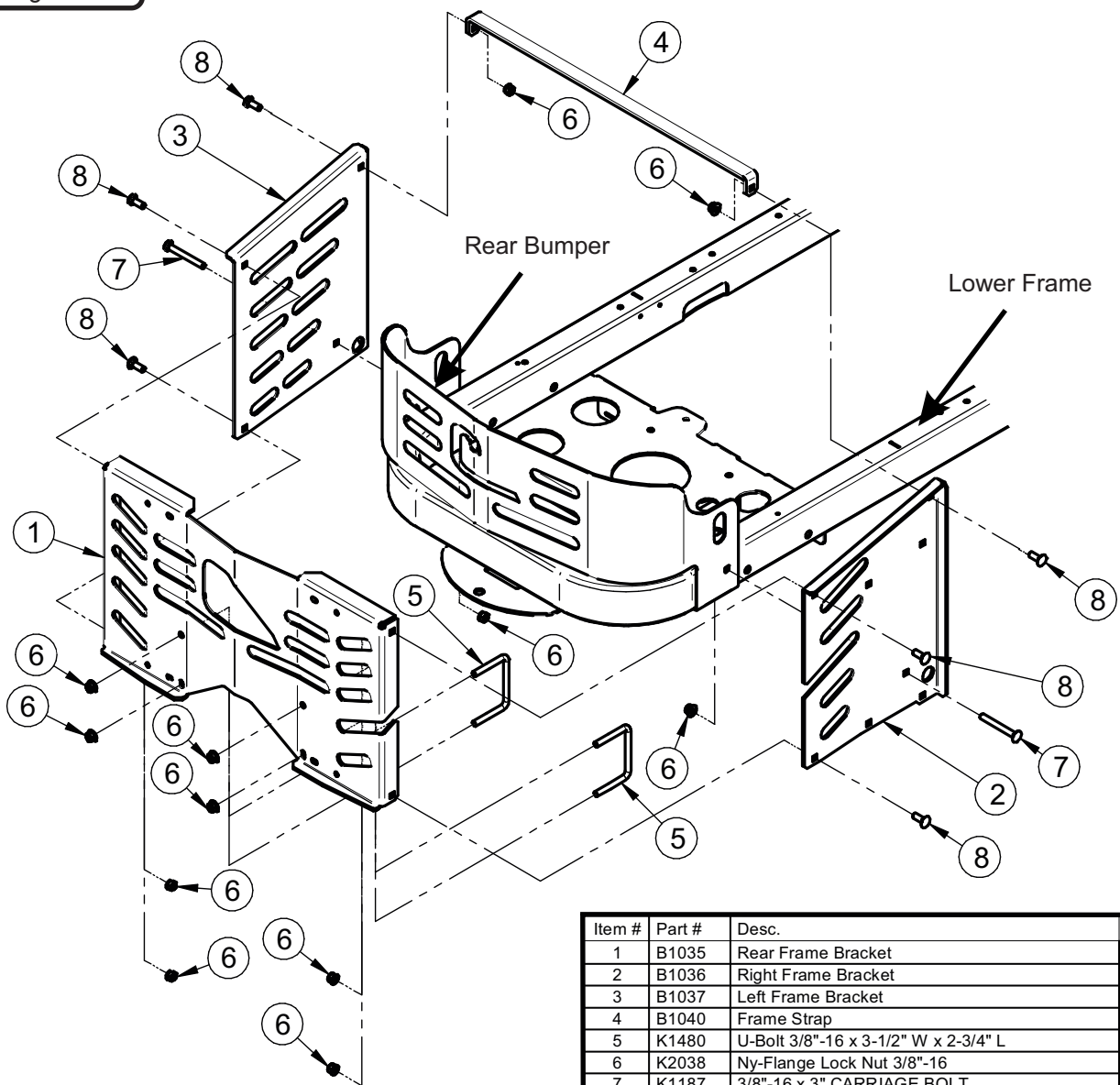
To install the Rear Frame Mount Kit, first remove the (2) existing bolts located on the left and right side of the rear bumper. Position the Rear Frame Bracket (Item#1) up against the rear bumper and secure the Rear Frame Bracket by fastening (2) 3/8"-16 x 3-1/2" U-Bolts (Item#5) and (4) 3/8"-16 Ny-Flange Lock Nuts (Item#6) around the mower's lower frame and through the bolt holes of the Rear Frame Bracket. (Refer to Figure A)

To install the Right Frame Bracket (Item#2) and the Left Frame Bracket (Item#3), align the mounting holes, located on the left side of the Right Frame Bracket and on the right side of the Left Frame Bracket, to the mounting holes of the Rear Frame Bracket. Secure the Right Frame Bracket to the Rear Frame Bracket by using (2) 3/8"-16 x 1" Carriage Bolts (Item#8) and (2) 3/8"-16 Ny-Flange Lock Nuts (Item#6). To secure the Right Frame Bracket to the mower's bumper, align the mount hole of the bumper to the bracket and use (1) 3/8"-16 x 3" Carriage Bolt (Item#7) and (1) 3/8"-16 Ny-Flange Lock Nut (Item#6). Repeat the steps for the Left Frame Bracket. (Refer to Figure A).

To install the Frame Strap (Item#4), align the mounting holes of the Frame Strap to the mounting holes on both the Left and Right Frame Bracket. Secure the Frame Strap by using (2) 3/8"-16 x 1" Carriage Bolts (Item#8) and (2) 3/8"-16 Ny-Flange Lock Nuts (Item#6).

Note: It is recommended to not tighten all hardware on the Right Frame Bracket until the PTO Mount Assembly has been installed so the parts could be easily positioned and aligned.

Figure A



Item #	Part #	Desc.	Qty.
1	B1035	Rear Frame Bracket	1
2	B1036	Right Frame Bracket	1
3	B1037	Left Frame Bracket	1
4	B1040	Frame Strap	1
5	K1480	U-Bolt 3/8"-16 x 3-1/2" W x 2-3/4" L	2
6	K2038	Ny-Flange Lock Nut 3/8"-16	12
7	K1187	3/8"-16 x 3" CARRIAGE BOLT	2
8	K1182	Carriage Bolt 3/8"-16 x 1"	6

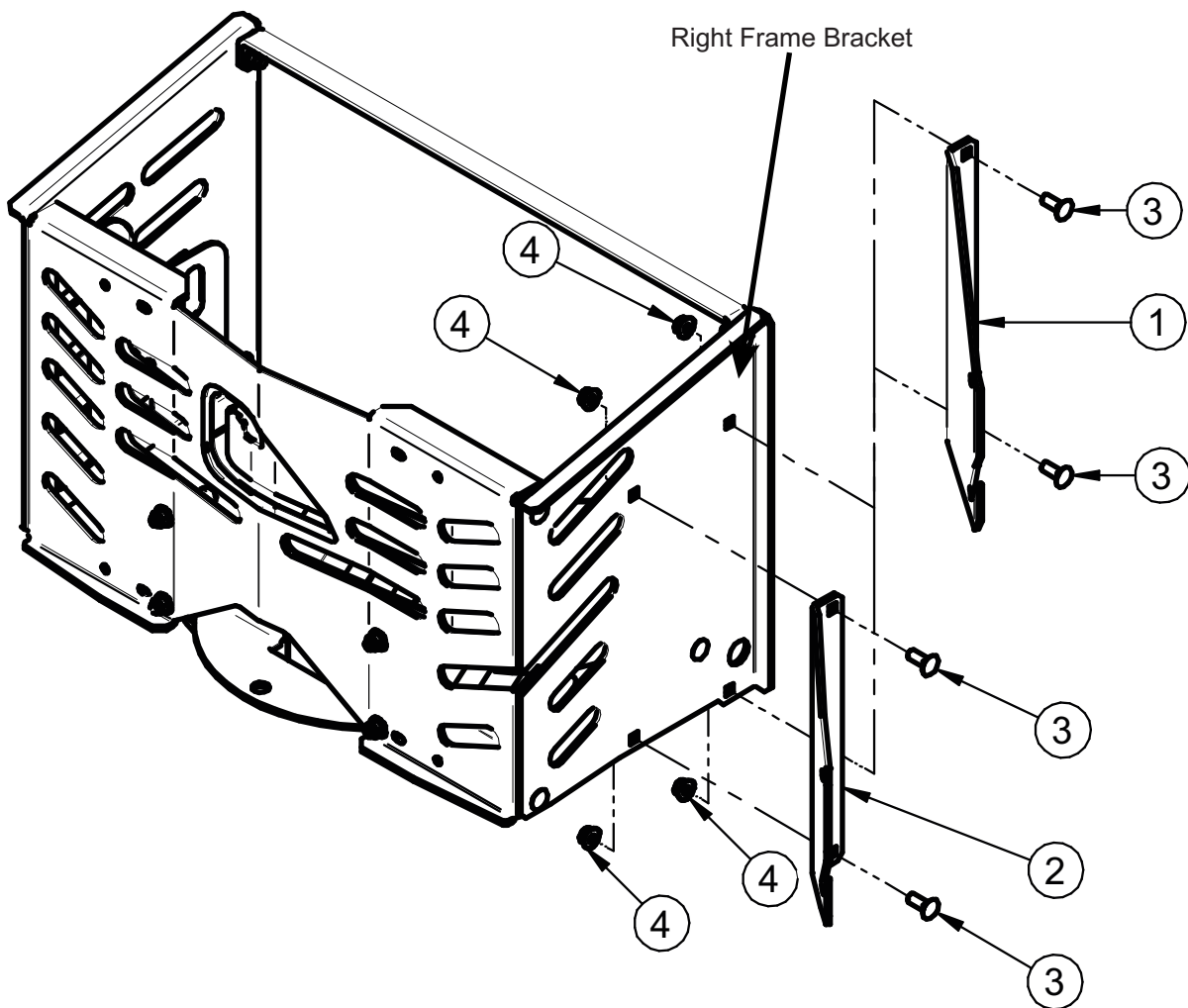
## PTO Mount Assembly Installation

To Install the Right PTO Mount Plate (Item #1), first align the mounting holes to the holes on the Right Frame Bracket as shown in Figure A. Secure the Right PTO Mount Plate by using (2) 3/8"-16 x 1" Carriage Bolts (Item#3) and (2) 3/8"-16 Ny-Flange Lock Nuts (Item#4). Next, align the mounting holes of the Left PTO Mount Plate (Item#2) to the mounting holes of the Right Frame Bracket. Secure the Left PTO Mount Plate by using (2) 3/8"-16 x 1" Carriage Bolts (Item#3) and (2) 3/8"-16 Ny-Flange Lock Nuts (Item#4). Refer to Figure A.

Tighten all hardware at this time.

Figure A

Item #	Part #	Desc.	Qty.
1	B1041	Right PTO Mount Plate	1
2	B1042	Left PTO Mount Plate	1
3	K1182	Carriage Bolt 3/8"-16 x 1"	4
4	K2038	Ny-Flange Lock Nut 3/8"-16	4



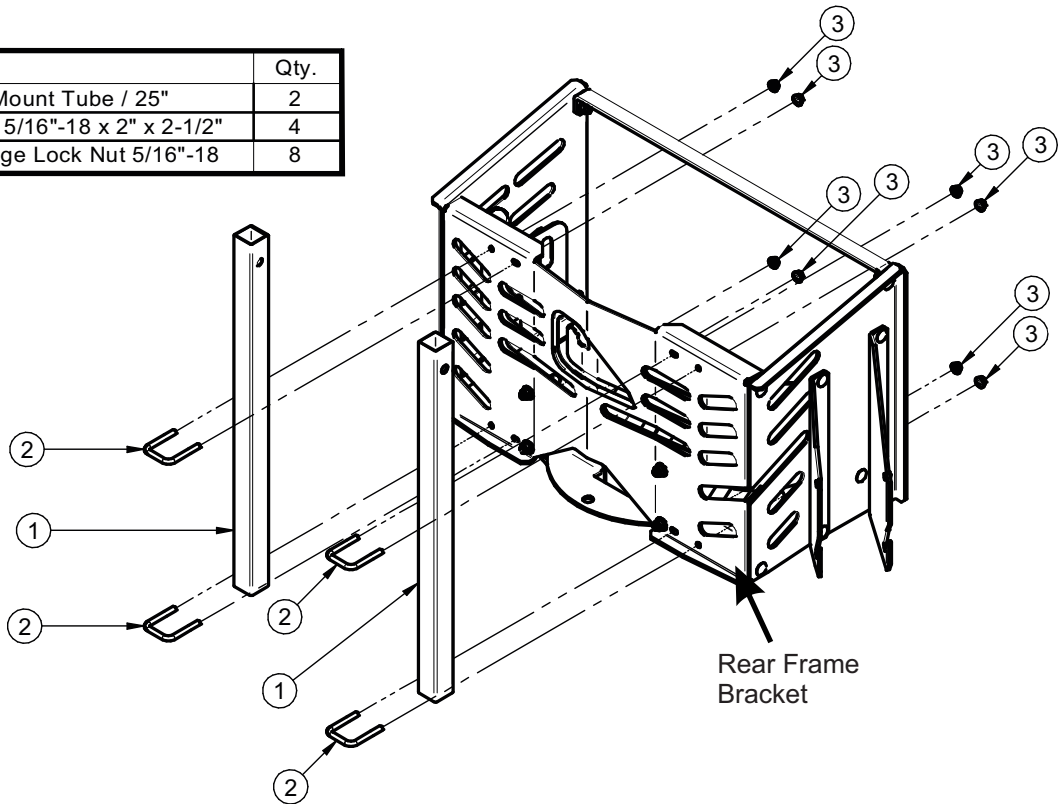


## Lower Mount Tube Installation

Secure (2) Lower Mount Tubes (Item #1) to the Rear Frame Bracket using (2) 5/16"-18 x 2" x 2-1/2" U-Bolts (Item #2) and (2) 5/16"-18 Ny-Flange Lock Nuts (Item #3) PER TUBE. Allow the Lower Mount Tubes to rest on the tabs of the Rear Frame Bracket. Refer to Figure A.

Figure A

Item #	Part #	Desc.	Qty.
1	B0752	Lower Mount Tube / 25"	2
2	K1098	U-Bolt / 5/16"-18 x 2" x 2-1/2"	4
3	K2516	Ny-Flange Lock Nut 5/16"-18	8

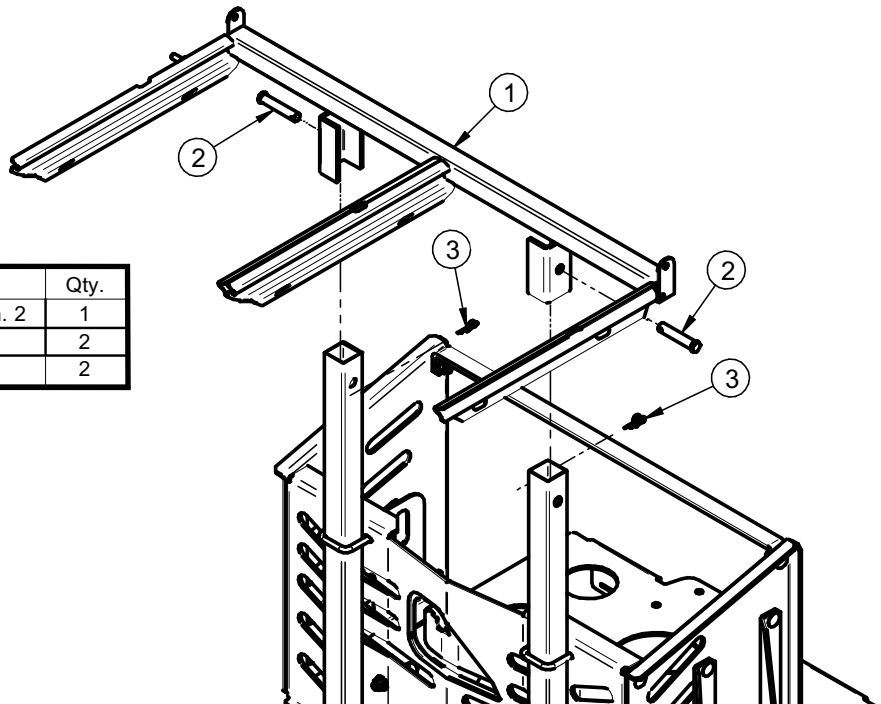


## Upper Frame Assembly Installation

Position the Upper Frame Assembly (Item #1) on top of the (2) Lower Mount Tubes aligning the holes of the Upper Frame Assembly to the holes of the Lower Mount Tubes. Use (1) Clevis Pin (Item #2) and (1) Hair Pin Clip (Item #3) PER LEG to secure the Upper Frame Assembly to the Lower Mount Tubes. Refer to Figure B.

Figure B

Item #	Part #	Desc.	Qty.
1	A2047	Upper Frame Assy / P2B+ Gen. 2	1
2	K0133	Clevis Pin 1/2" x 2-1/2"	2
3	K1437	Rue Ring Cotter Pin	2

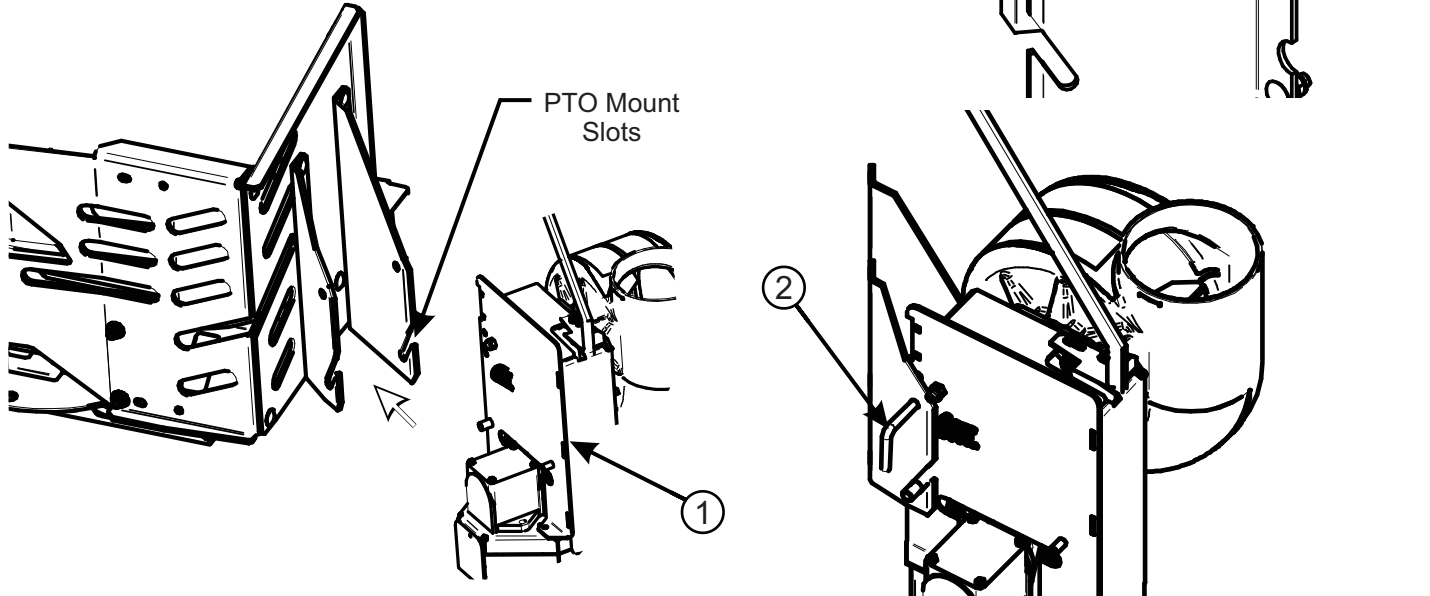


## PTO Drive Assembly Installation

Locate the PTO mounting slots on both the Left and Right PTO Mount Plates. Insert the pivot rod of the PTO Assembly (Item#1) into the mounting slots of the Left and Right PTO Mount Plates. Secure the PTO Assembly by using (1) PTO Assembly Mount Pin (Item#2) and (1) Hair Pin Clip (Item#3). Refer to Figure A.

Figure A

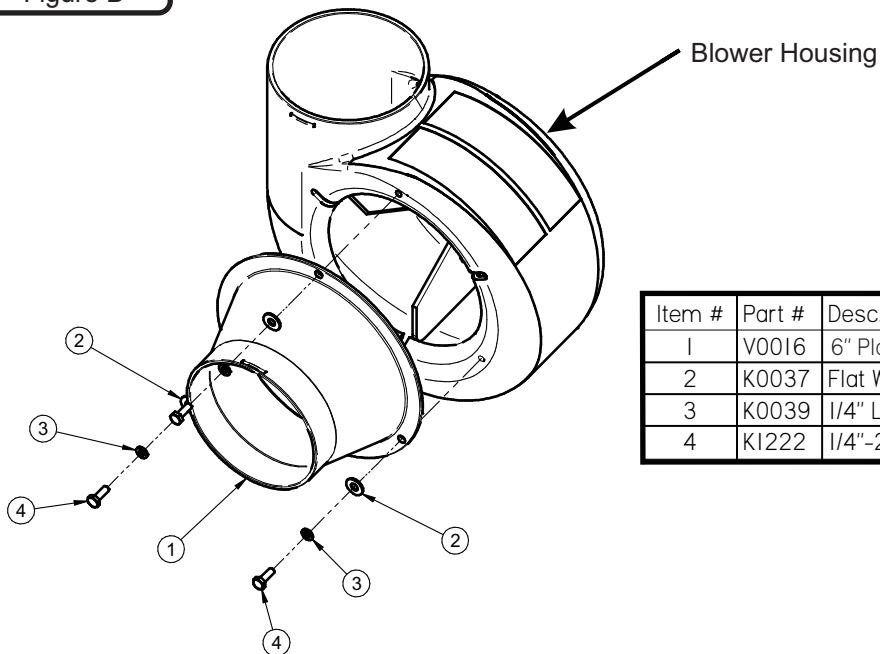
Item #	Part #	Desc.	Qty.
1	A2154	PTO Assy. / 3-Blade Impeller	1
2	B0274	PTO Assy. Mnt. Pin	1
3	K0086	Hair Pin Clip .125 OD x 2.50	1



## Blower Cone Installation

Align the bolt holes of the 6" Plastic Cone (Item#1) to the bolts holes located on the Blower Housing of the PTO Assembly. Secure the 6" Blower Cone to the Blower Housing by using (3) 1/4"-20 x 3/4" HHCS (Item#4), (3) 1/4" Lock Washers (Item#3), and (3) 1/4" Flat Washers (Item#2). Refer to Figure B.

Figure B

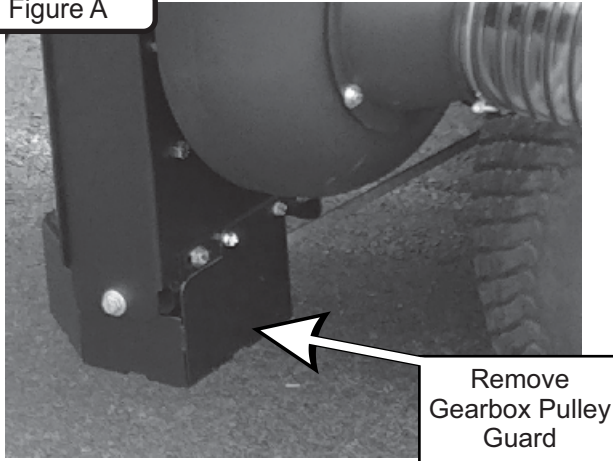


Item #	Part #	Desc.	Qty.
1	V0016	6" Plastic Blower Cone	1
2	K0037	Flat Washer / 1/4" (.75 OD x .312 ID x .060 T)	3
3	K0039	1/4" Lock Washer	3
4	K1222	1/4"-20 X 3/4" HHCS	3

## Belt Installation and Adjustment PTO MODELS ONLY

Remove (3) 1/4"-20 x 1/2" HHSTS P#(K0353) from the gearbox pulley guard located on the bottom of the PTO assembly (Refer to Figure A).

Figure A



Loosen the (4) bolts P#(K1153), (2) on each side, that secure the gear box assembly to the PTO assembly P#(A1950) (Figure B and C).

Figure B

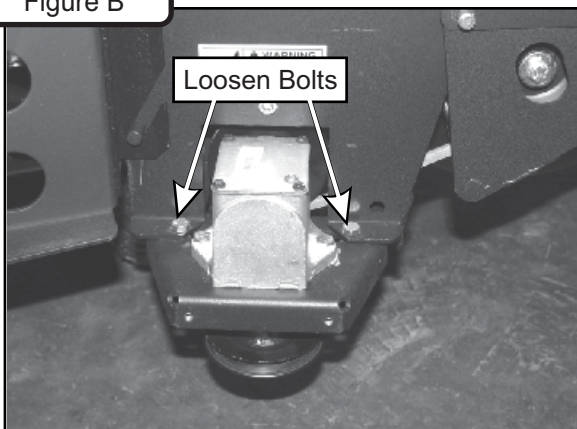
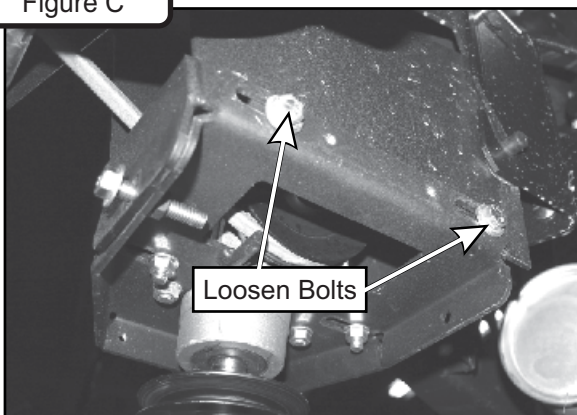
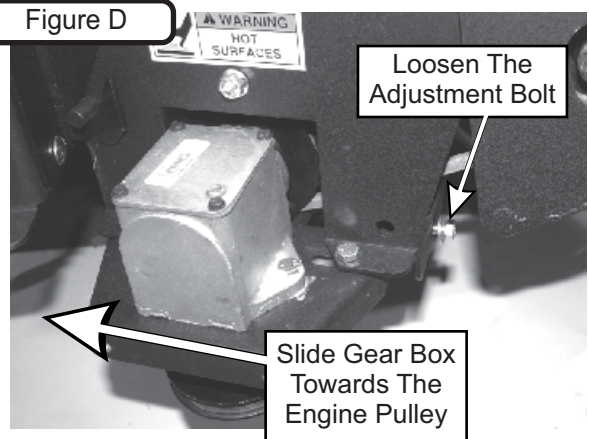


Figure C



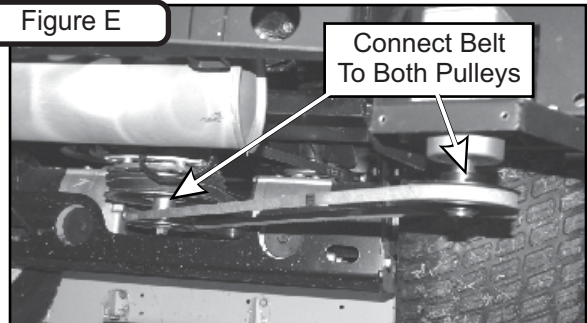
Loosen the adjustment bolt P#(K0348) until the gear box assembly is at its far left adjustment (the gear box is moved toward the mower's engine pulley). Refer to Figure D.

Figure D



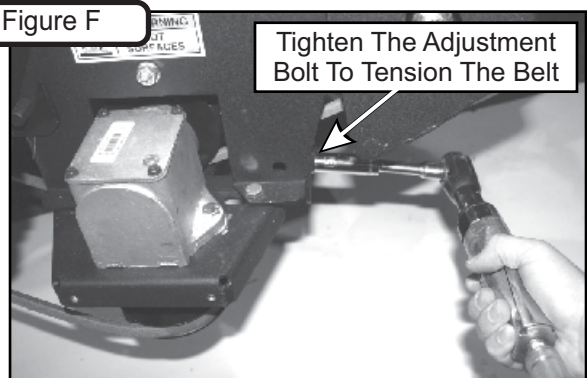
Connect the belt A56K P#(M0239) from the engine pulley to the lower gear box pulley (Figure E).

Figure E



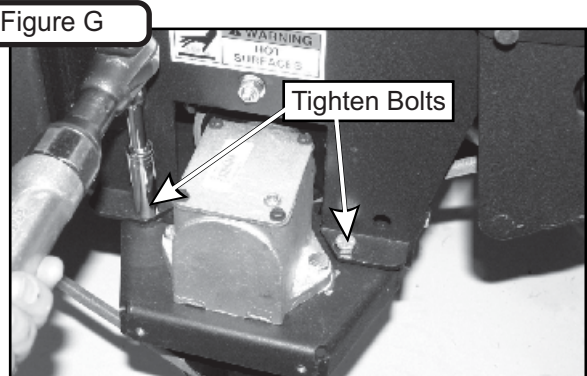
To tension the drive belt, turn the adjustment bolt clockwise (Figure F) until there is 1" of deflection, with 10-11 lbs. of pressure, at the center of the belt between the engine pulley and the gear box pulley.

Figure F



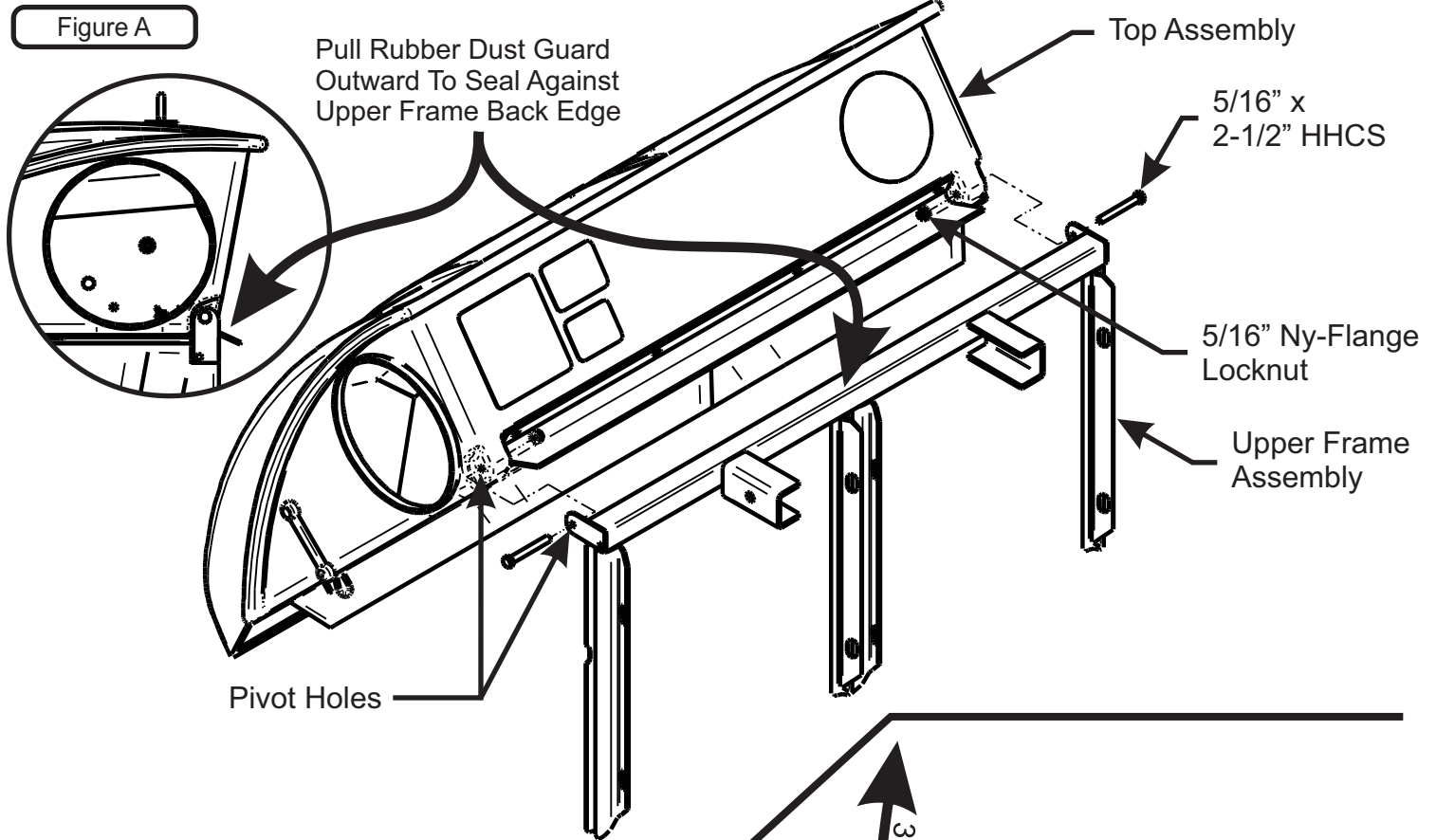
Once the correct tension of the belt is achieved, tighten the (4) bolts that secure the gear box assembly. Refer to Figure G. Replace the belt guard.

Figure G



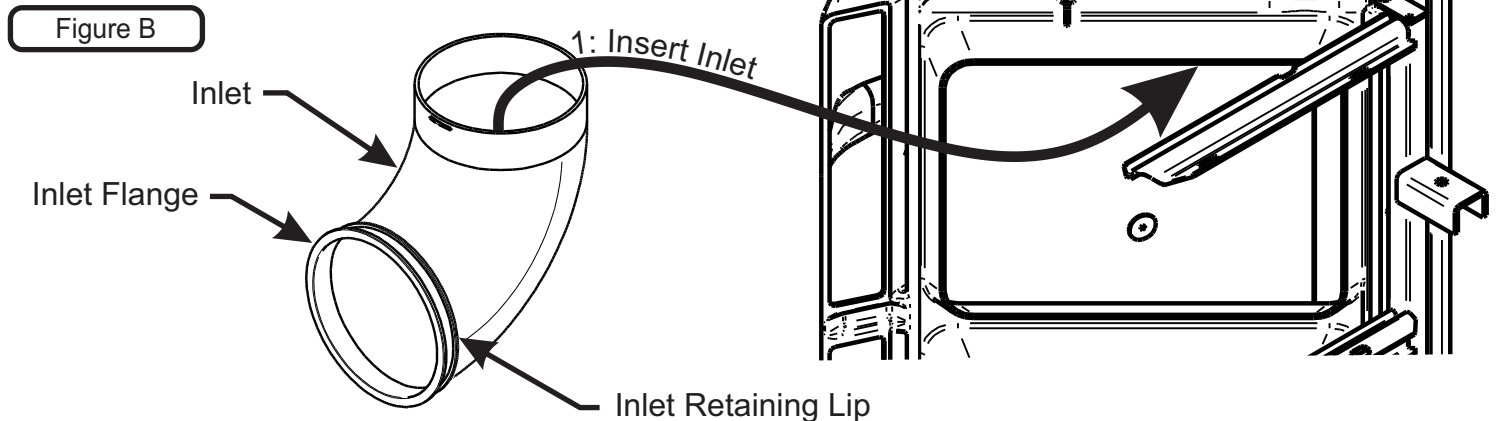
## Top Assembly To Upper Frame Assembly Installation

Align the Top Assembly Pivot Holes to the Upper Frame Assembly. See Figure A below. Before fastening, pull Rubber Dust Guard outward to seal against Upper Frame Assembly (towards the mower's operator seat). Fasten the Top Assembly to the Upper Frame Assembly using (2) 5/16"-18 x 2-1/2" HHCS P#(K0125) and (2) 5/16"-18 Ny-Flange Locknuts P#(K2516). Leave the Ny-Flange Locknuts slightly loose to allow the Top Assembly to open and close easily.



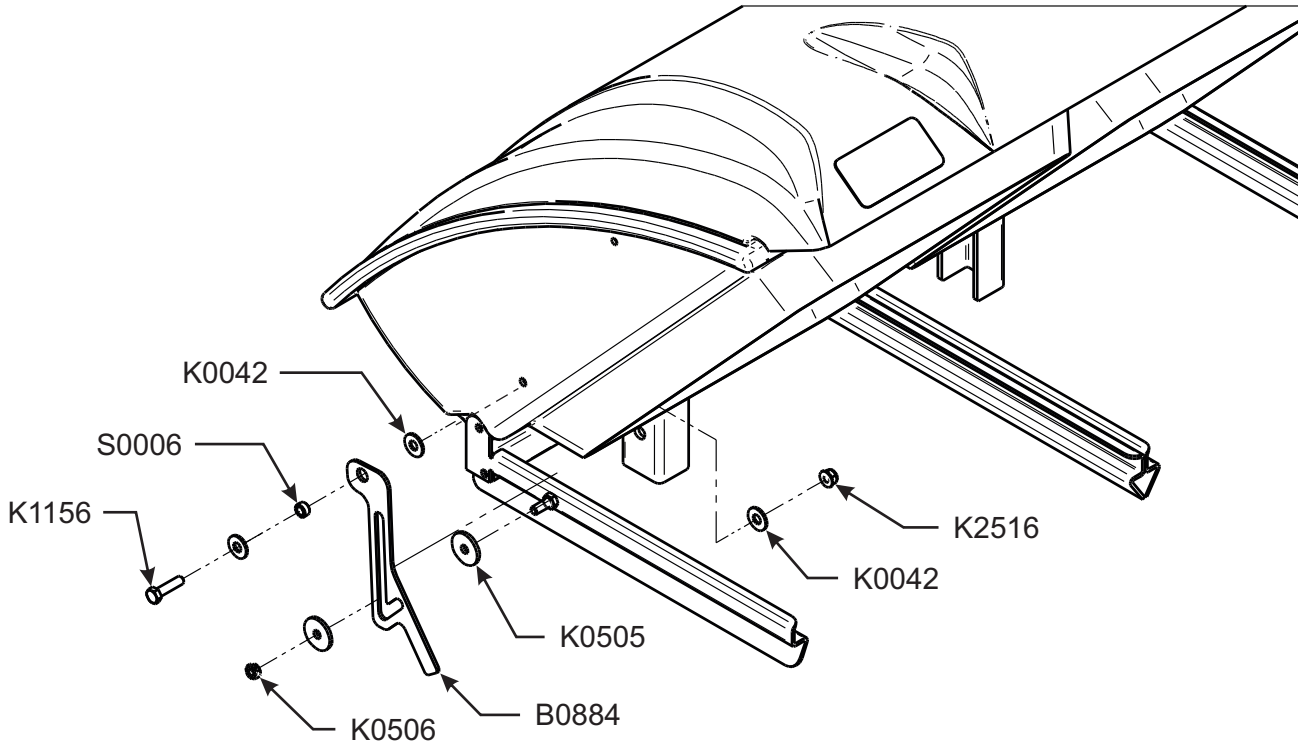
## Inlet Installation

Position the Top Assembly on its side with the Inlet Hole facing up. See Figure B. 1: Insert the Inlet from inside the Top Assembly, up through the Inlet Hole, until the Inlet Retaining Lip meets the Inlet Hole. 2: Position the Inlet as shown in Figure B, then pull the Inlet until a portion of the Inlet Retaining Lip protrudes from the Inlet hole. 3: Next, lift the Inlet as shown in Figure B until all of the Inlet Retaining Lip protrudes from the Inlet Hole. Once installed, the Inlet should pivot freely about the Inlet Hole.



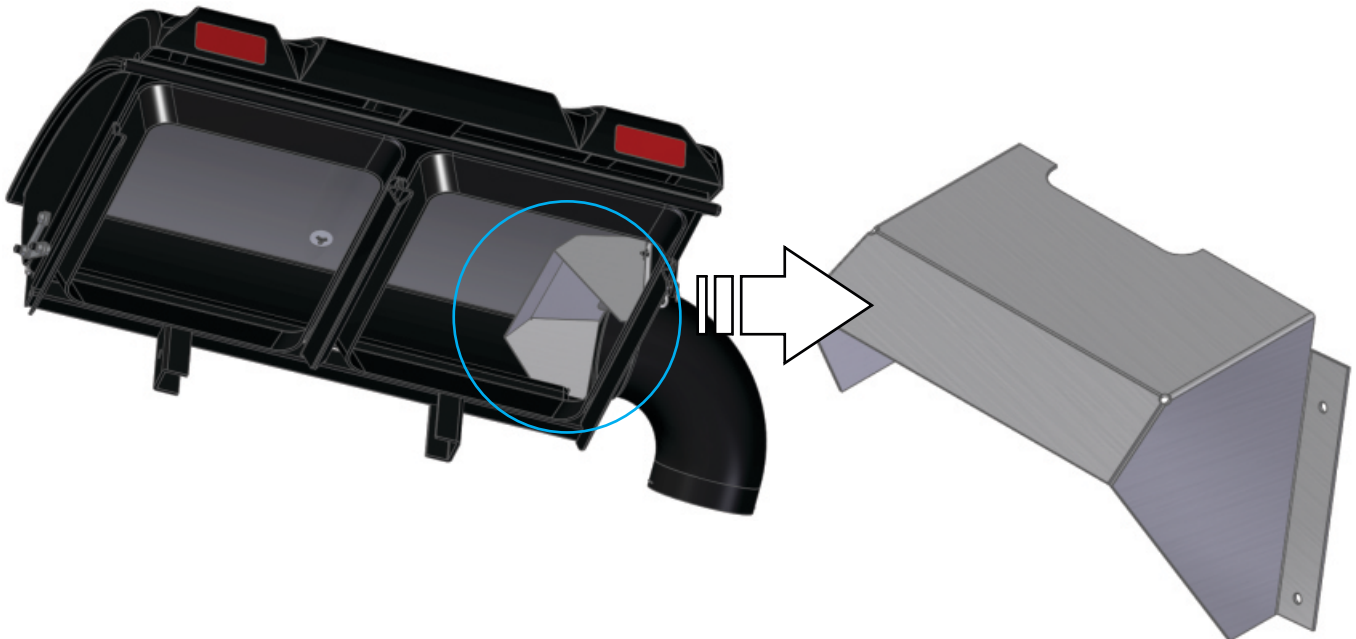
## Hinge Kit Assembly Installation

Assemble the Hinge Kit using (1) Latch Plate P#(B0884), (1) 5/16"-18 x 1-1/4" HHCS P#(K1156), (1) 5/16"-18 Ny-Flange Lock Nut P#(K2516), (3) 5/16" Flat Washers P#(K0042), (1) Latch Spacer P#(S0006), (2) Extra Heavy 5/16" Fender Washers P#(K0505) and (1) 5/16"-18 Lock Nut P#(K0506). Leave the nuts loose enough to allow fluid movement of the top when opening and closing. When opened, the top should rest in the Latch Plate Slot.



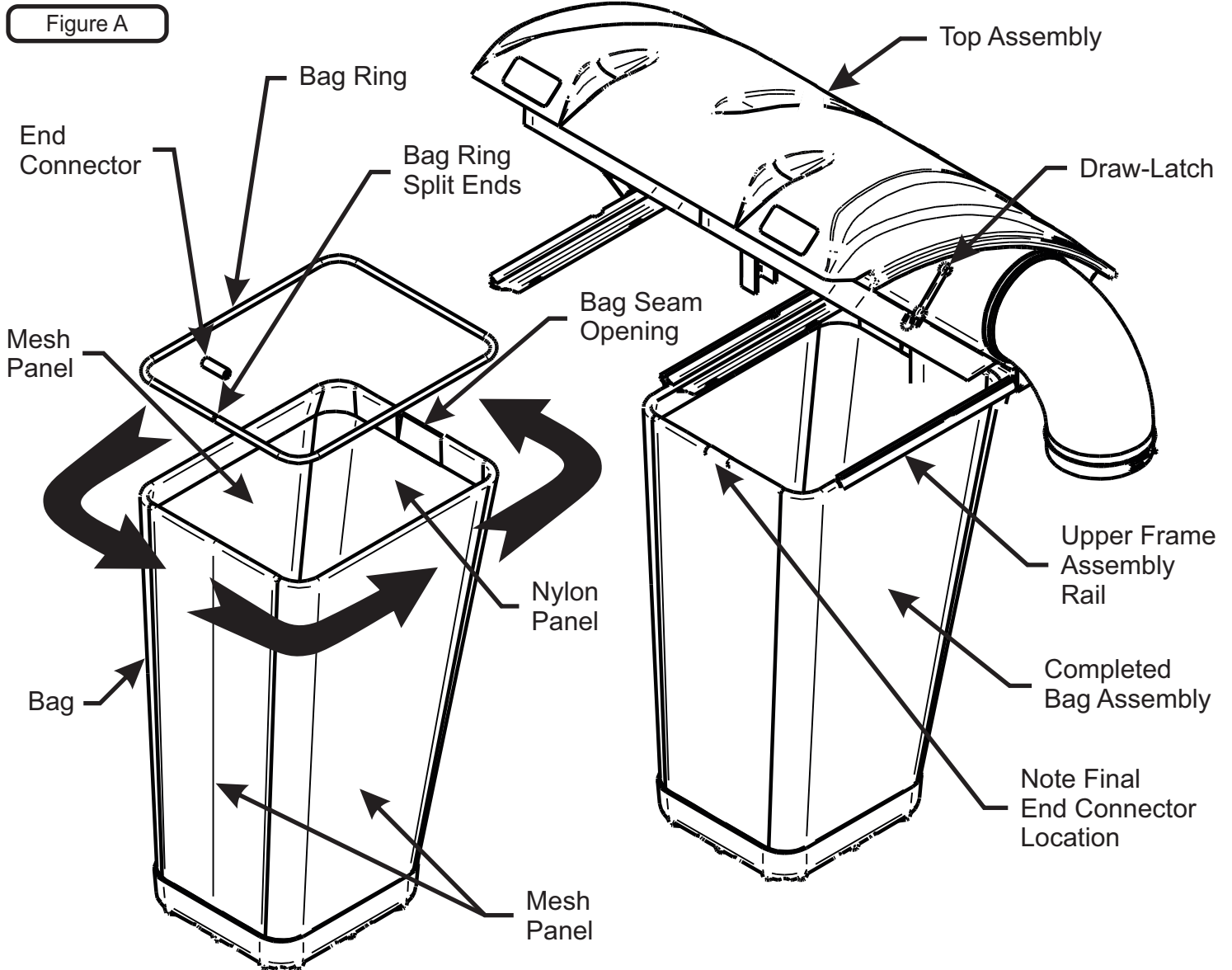
## Even Bag Fill Adjustment

Flap can be adjusted Up/Down depending on mowing conditions. Adjust flap up to allow more dense material to reach left bag. Adjust flap down to allow less dense material to reach the right bag. Once adjusted properly, both bags should fill evenly, but may require further adjusting when mowing conditions change.



## **Bag Assembly**

First, take one of the Bag Ring Split Ends and insert it through the Bag Seam Opening. Next, rotate the Bag around the Bag Ring (1) full turn (360 degrees) until the Bag Ring Split Ends and the Bag Seam Opening are positioned on the same side. Then, connect the Bag Ring Split Ends using (1) End Connector. Last, rotate the Bag Ring and the End Connector Assembly (1/2") turn (180 degrees) to position the Connector opposite of the Bag Seam Opening. Note Final End Connector Location below in Figure A. Repeat for each Bag.



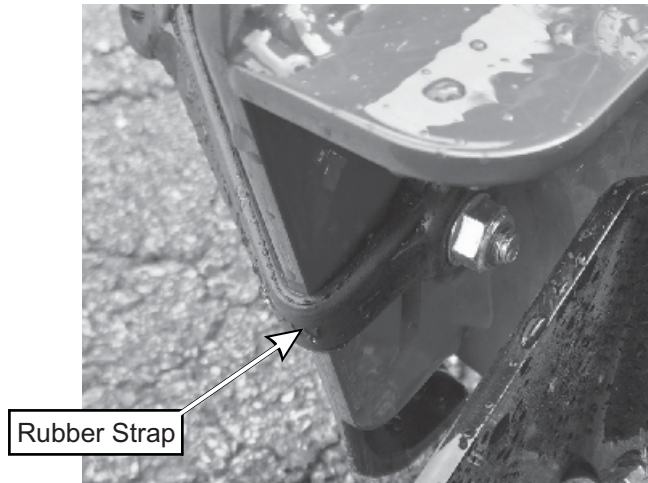
## **Bag Assembly Installation**

Slide the Completed Bag Assembly into the Upper Frame Assembly Rails and close the Top Assembly. Fasten the Draw-Latch on either side to hold the bagger closed.

## Boot Kit Installation

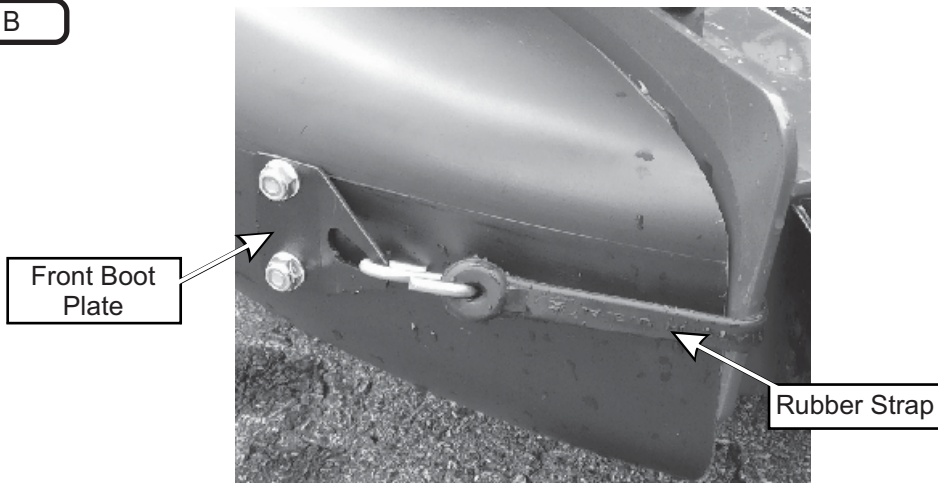
Attach Rubber Strap P#(J4009) to mower deck using (1) P#(K1025) 1/4"-20 Carriage Bolt, (1) P#(K0037) 1/4" Flat Washer and (1) P#(K2014) 1/4"-20 Ny-Flange Lock Nut. Open end of hook should be facing deck discharge. Refer to Figure A

Figure A



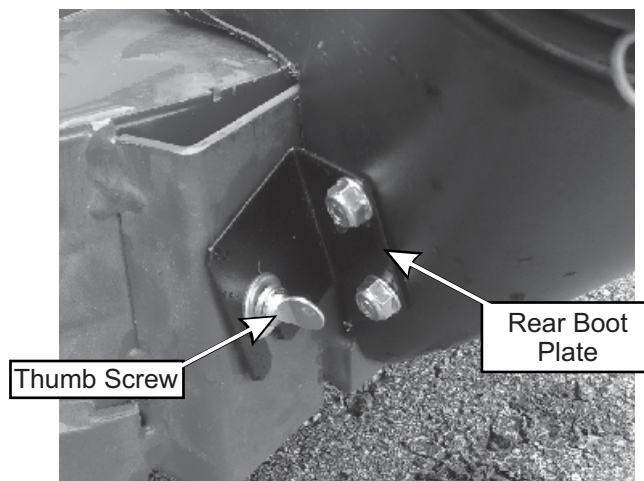
Attach Front Boot Plate P#(B0920) to outside of the Boot and the Boot Plate Fastener P#(B0922) on the inside using (2) P#(K1010) 1/4"-20 x 5/8" Carriage Bolts and (2) P#(K2014) 1/4"-20 Ny-Flange Lock Nuts. Refer to Figure B.

Figure B



Attach the Rear Boot Plate P#(B0921) to the outside of the Boot and Boot Plate Fastener P#(B0922) to the inside using (2) P#(K1010) 1/4"-20 x 5/8" Carriage Bolts and (2) P#(K2014) Flange Lock Nuts to the Boot. Secure Rear Boot Plate using (1) P#(J0008) Thumb Screw with 1/4"-20 x 1/2" threads, (1) P#(K0037) 1/4" Flat Washer and (1) P#(K0039) 1/4" Lock Washer to mower deck. Refer to Figure C.

Figure C



## Length Of Hose Adjustment

The hoses in the following steps must be cut to fit your machine. Do not cut the hoses until you have tried to fit them on your machine. Remember that the hoses need to be long enough to allow for the opening and closing of the collection system as well as allowing ample clamping surface between each component.

## Upper Hose Installation

Slide a Hose Clamp P#(J0060) over one end of the 6" Upper Hose. Secure this end of the 6" Upper Hose to the Blower Outlet. See Figure below for details. Secure opposite end of the 6" Upper Hose to the Inlet. Make sure both ends are securely fastened by tightening the Hose Clamp and rotating the Inlet Snap Fastener towards the hose to lock in place.

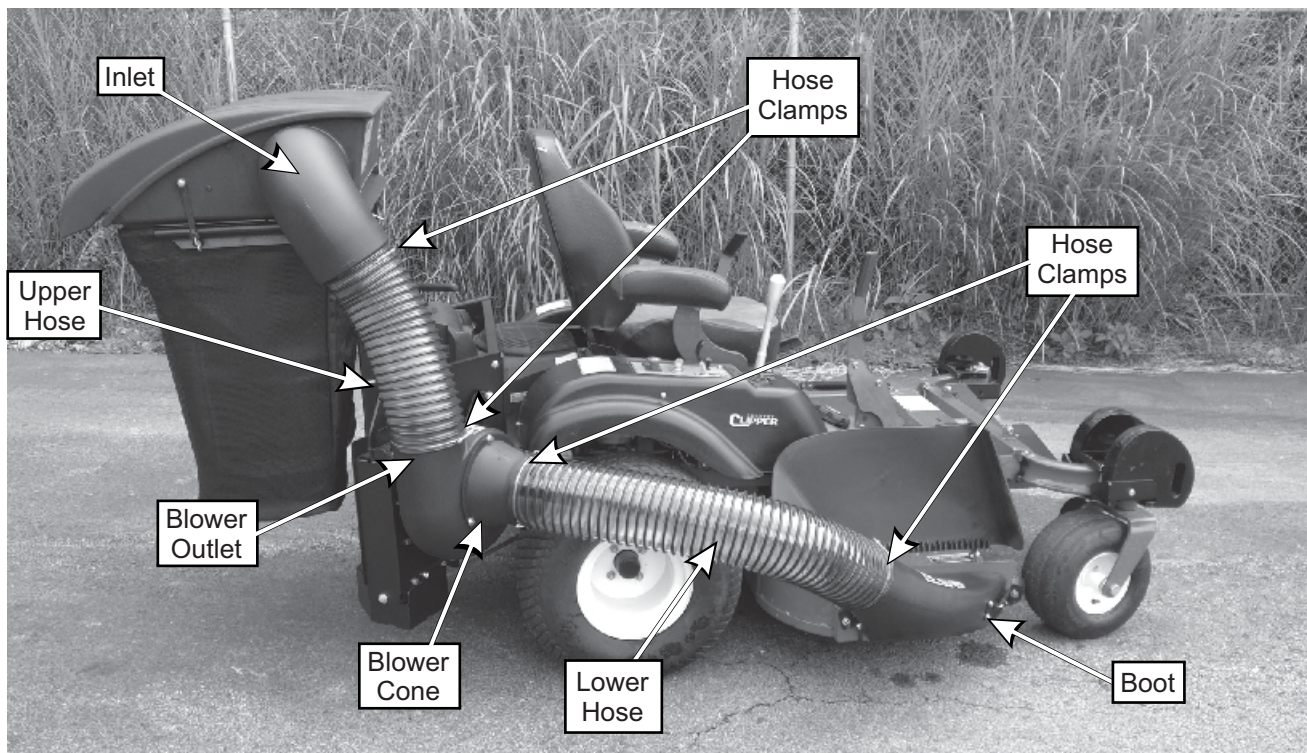
## Lower Hose To Blower Cone Installation

Slide a Hose Clamp P#(J0060) over both ends of the Lower Hose. Secure one end of the Lower Hose to the Blower Cone and fasten by tightening the Hose Clamp.

## Lower Hose To Boot Installation

Take the unattached end of the Lower Hose and secure it to the circular end of the Boot and fasten by tightening the Hose Clamp.

Tip: Before securing Hose Clamp fully, rotate Lower Hose counter-clockwise (away from yourself) approximately 1" to aid in retaining Boot to mower deck.





## Impeller Blade Removal/Replacement

**To Remove:** To access the impeller blade, remove the Blower Cone and Blower Cone Hardware from the Blower Housing (Item#1). Remove the 5/16"-24 x 1-1/4" LH HHCS (Item#3) and (1) Washer (Item#4) (Refer to Figure A). Insert (1) 1/2"-13 x 1" Hex Bolt into the threads on the Impeller Blade (Refer to Figure B). Tighten the Hex Bolt until the Impeller Blade breaks free from the PTO Shaft. Remove the Impeller Blade Assembly (Item#2) from the PTO Shaft. Remove the Key (Item#5) from the PTO shaft.

**To Replace:** Insert the Key (Item#5) into the keyway slot on the PTO Shaft. Align the keyway slot on the Bushing of the Impeller Blade Assembly with the Key on the PTO Shaft and insert the Impeller Blade onto the PTO Shaft. Secure the Impeller Blade with (1) 5/16"-24 x 7/8" LH HHCS (Item#3) and (1) Washer (Item#4) (Refer to Figure A). Replace the Blower Cone and Blower Cone Hardware.

NOTE: Figure A is portraying a cross section view of the PTO Blower Housing.

Figure A

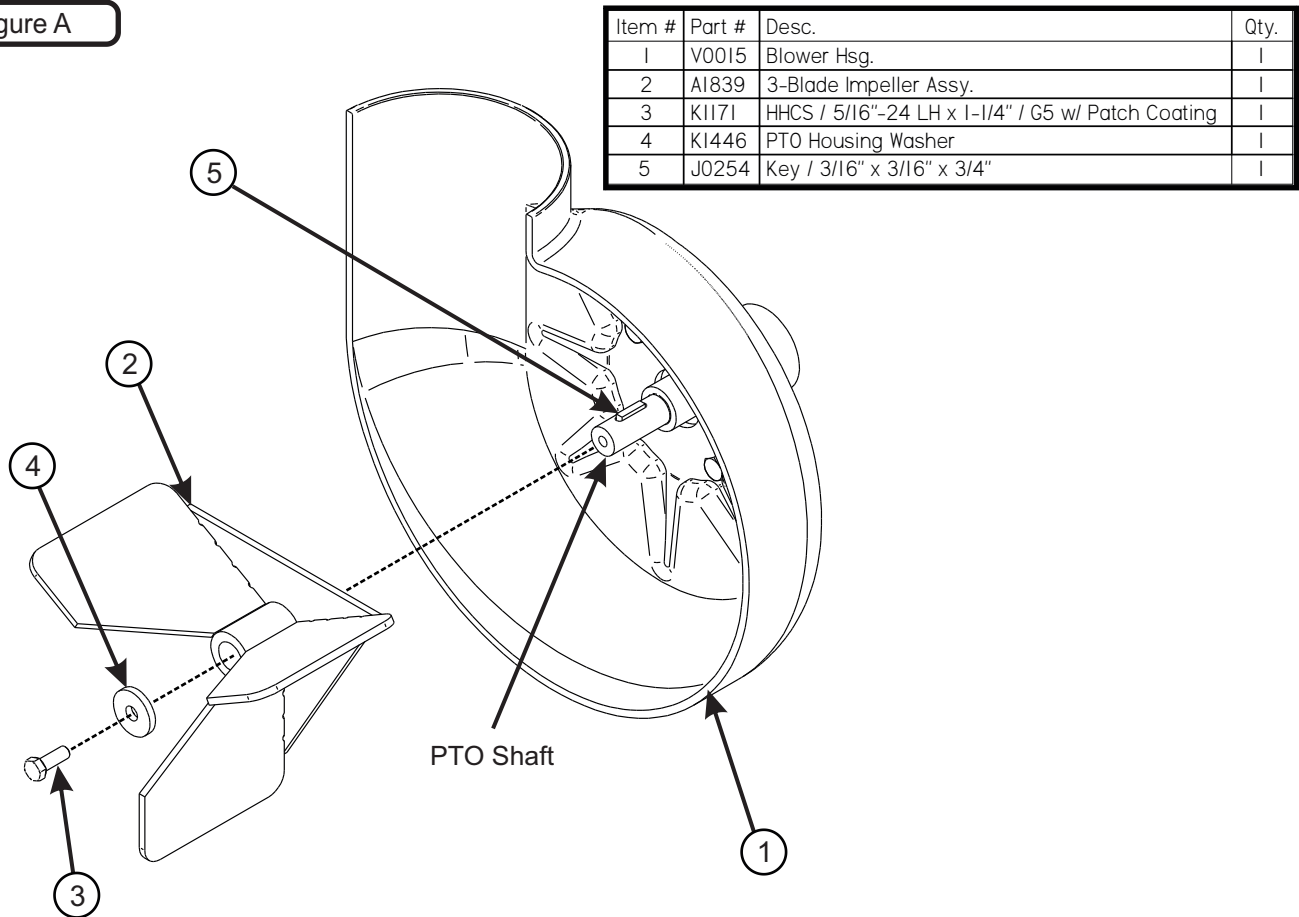
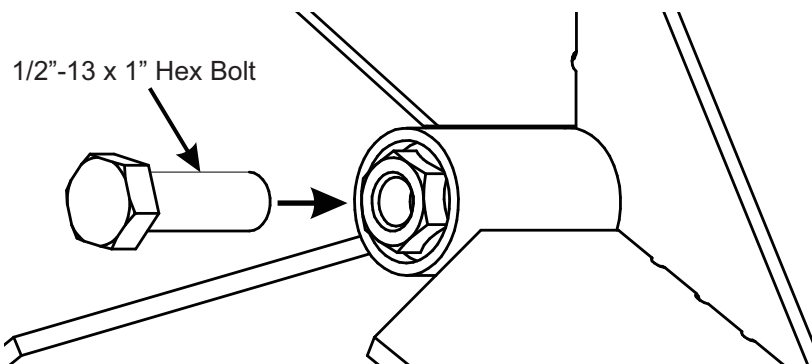


Figure B



## Weight Kit Installation

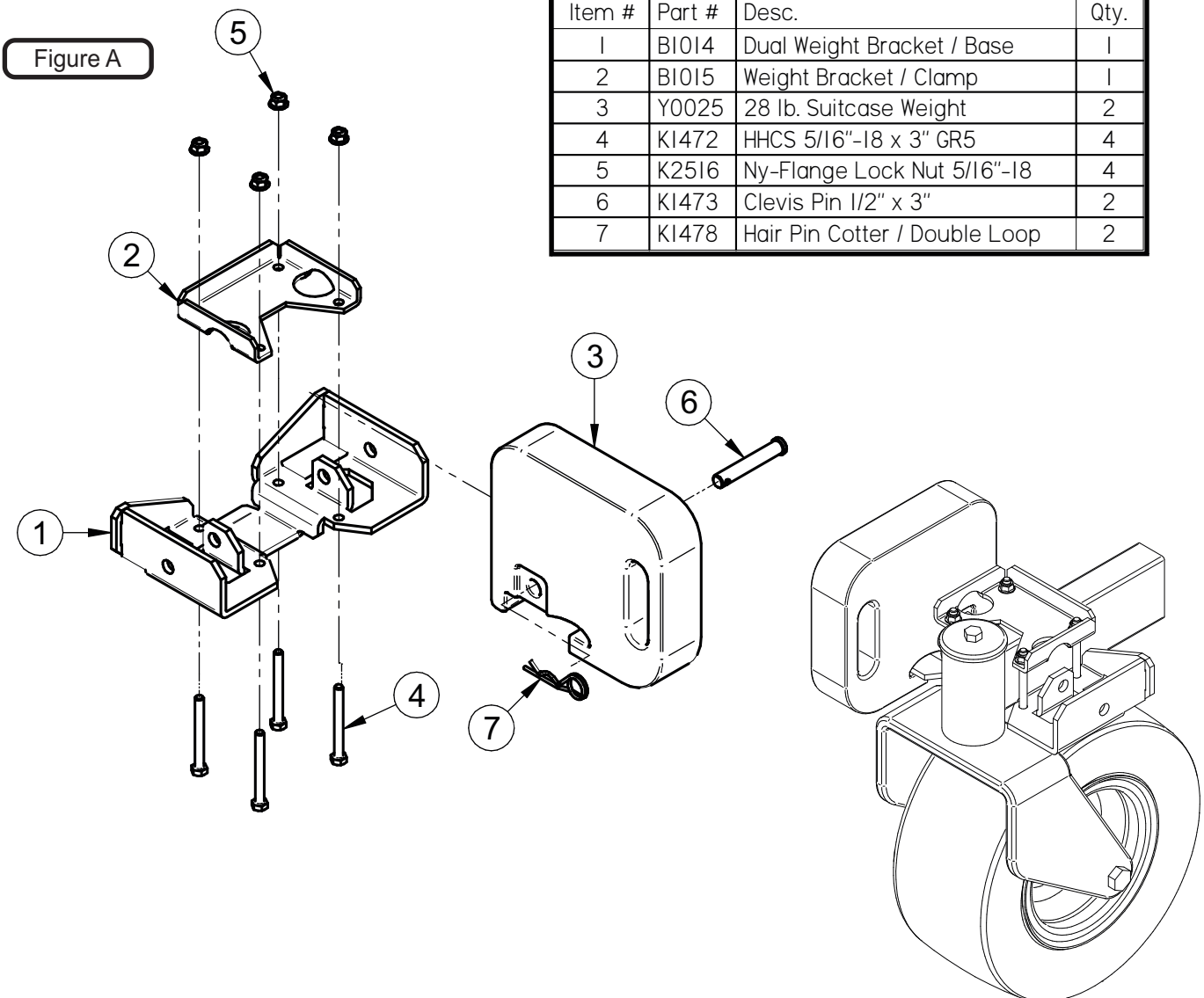
Position the Dual Weight Bracket Base (Item#1) under the caster tubing w/ opening towards caster fork. Next, position the Weight Bracket Clamp (Item#2) on top of caster tubing w/ opening towards caster fork.

Align the (4) holes of the Weight Bracket Clamp (Item#2) to the holes in the Dual Weight Bracket Base (Item#1). Loosely fasten the Weight Bracket Clamp (Item#2) to the Weight Bracket Base (Item#1) using (4) 5/16"-18 x 3" Bolts (Item#4) & (4) 5/16"-18 Ny-Flange Lock Nuts (Item#5).

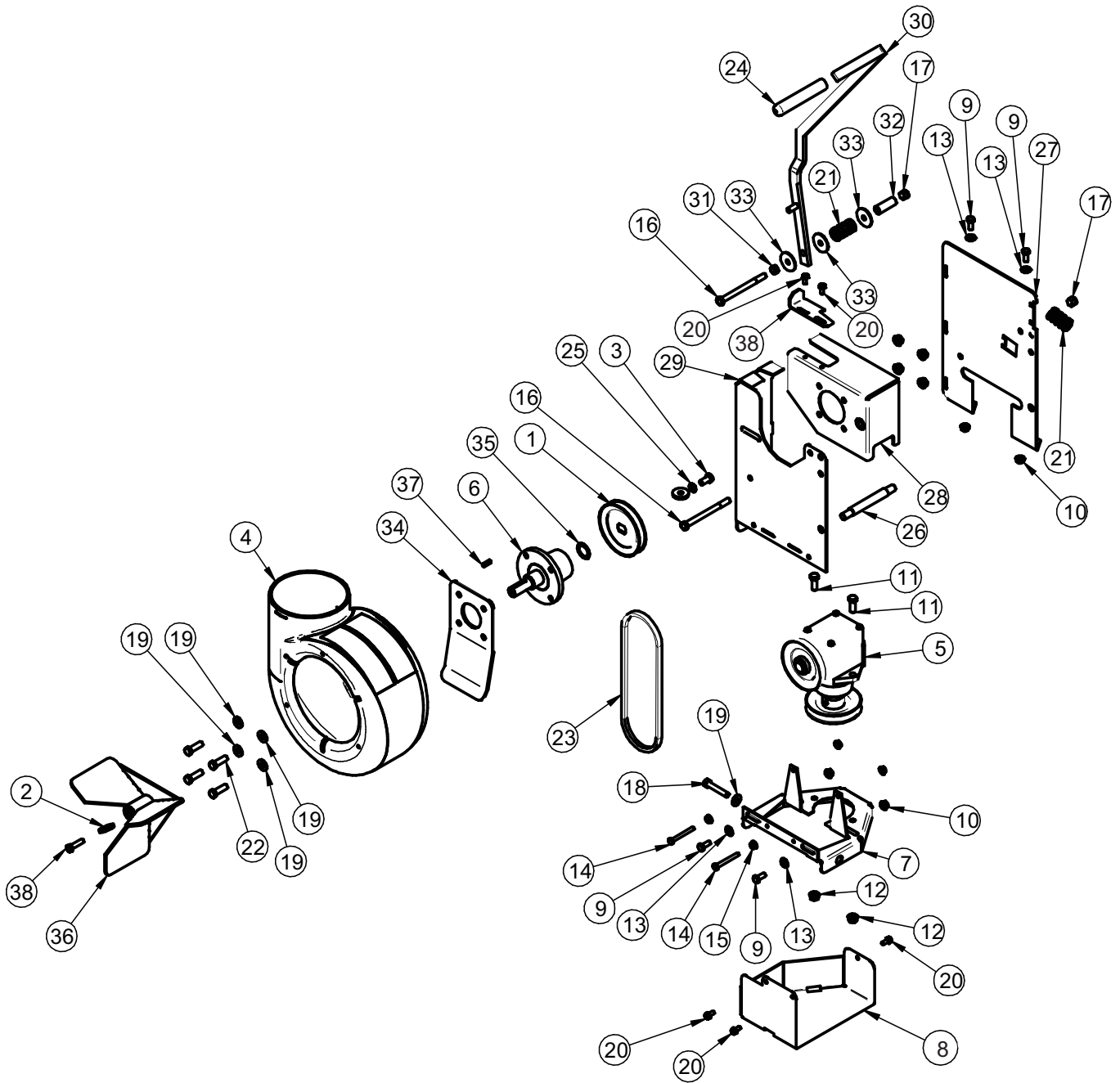
Position the Weight Bracket Base and the Weight Bracket Clamp assembly along the caster tubing to prevent interference from caster forks or any other objects. Tighten the fasteners in an 'X' pattern until assembly is firmly clamped to caster tubing. Do not over tighten which may result in bending Weight Bracket Clamps (Item#3).

Insert (1) Weight (Item#3) Into the Weight Bracket Base (Item#2) & align the holes of the Weight w/ the holes of the Weight Bracket Base (Item#2). Fasten the Weight (Item#1) to the Weight Bracket Base Using (1) Clevis Pin (Item#6) & (1) Hair Pin Clip (Item#7) per weight.

Repeat on additional caster. Refer to the Figure Below.



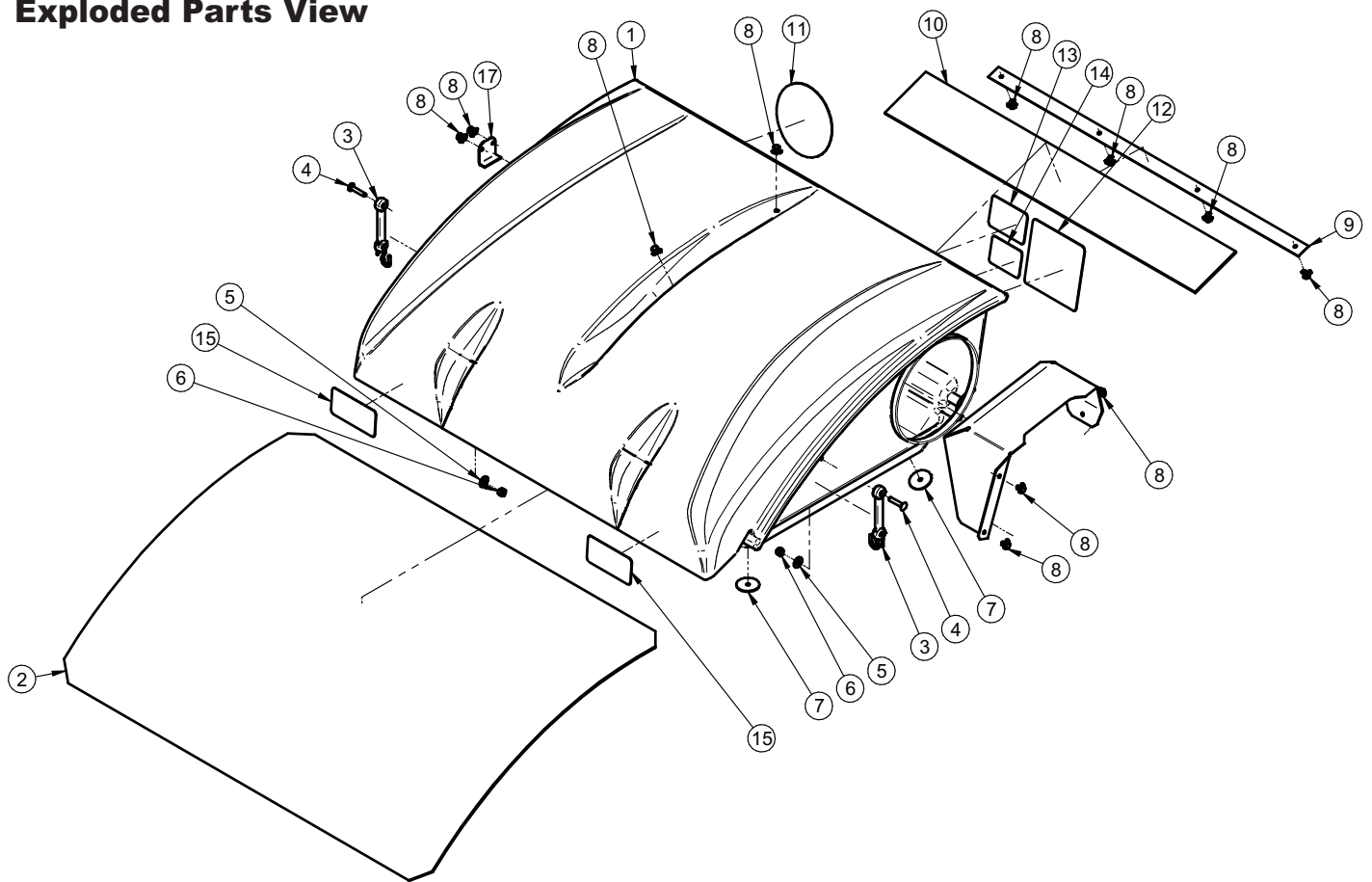
# A2154 PTO Drive Assembly / 3 Blade Impeller



## A2154 Drive Assembly / 3 Blade Impeller

Item #	Part #	Desc.	Qty.
1	M0266	A-Section Pulley / 4.25 OD	1
2	K1446	PTO Housing Washer	2
3	k1190	HHCS / 3/8"-16 x 3/4"	1
4	V0015	Blower Hsg.	1
5	A0429	Gear Box Assy.	1
6	A1004	PTO Shaft Assy.	1
7	A1003	PTO Base Plate Assy.	1
8	B0478	Gear Box Pulley Guard	1
9	K1153	HHCS 5/16"-18 x 3/4"	4
10	K1178	Flange Nut 5/16"-18	4
11	k1191	HHCS 3/8"-16 x 1" GR5	2
12	K1215	Flange Nut 3/8"-16	6
13	K0037	Flat Washer / 1/4" (.75 OD x .312 ID x .060 T)	4
14	k1150	HHCS / 1/4"-20 x 2-1/4"	2
15	K1126	Flange Nut 1/4"-20	4
16	K1202	HHCS / 3/8"-16 x 4-1/2" / G5	2
17	k1216	Nyloc Nut / 3/8"-16	2
18	K0348	HHCS / 3/8"-16 x 2" All Thread	1
19	k0042	Flat Washer 5/16" / .875 OD x .380 ID x .075 T	5
20	K0353	HWHTCS 1/4"-20 x 1/2"	5
21	J0303	Spring	2
22	K1192	HHCS 3/8"-16 x 1-1/4" GR5	4
23	M0267	Kevlar Belt / A28K	1
24	V1151	Black Handle Grip (5/8" ID x 4-3/4" L)	1
25	K0048	Lock Washer 3/8"	1
26	B0505	Mount Rod	1
27	B0506	Lt. PTO Arm	1
28	B0642	Mount Bracket / Blower Hsg.	1
29	B0643	Rt. PTO Arm	1
30	A1137	PTO Handle Assy.	1
31	B0510	Spacer Bushing / Small	1
32	B0511	Spacer Bushing / Large	1
33	K0403	Flat Washer (1-1/2" OD x 3/8" ID x .092 T)	3
34	B0739	Stiffener Plate / Blower Hsg.	1
35	K0070	Flat Washer (1.295 OD x .881 ID x .020 T)	1
36	A1839	3-Blade Impeller Assy.	1
37	J0254	Key / 3/16" x 3/16" x 3/4"	1
38	K1171	HHCS / 5/16"-24 LH x 1-1/4" / G5 w/ Patch Coating	1
39	B0887	Belt Tension Adjust Bracket	1

## A2101 Top Assembly Exploded Parts View



Item #	Part #	Desc.	Qty.
1	V2000	Pro 2 Bagger Top / Gen. 2	1
2	V2001	Screen	1
3	J4009	Short Rubber Strap w/ S-Hook	2
4	K1030	1/4"-20 x 1-1/4" Carriage Bolt	2
5	K0037	Flat Washer / 1/4" (.75 OD x .312 ID x .060 T)	2
6	K1128	1/4"-20 Nyloc Nut	2
7	K0062	Fender Washer / .230 ID x 1.500 OD / Zinc	2
8	K0114	Black Plastic Rivet	11
9	C0067	Dust Guard Mnt. Brkt.	1
10	V1117	Dust Guard	1
11	R0022	Decal / Built In The USA / Lg	1
12	R1069	Decal / Warning - Turn Off Blower	1
13	R1054	Decal / Important Check Hoses	1
14	R1051	Decal / Warning - Use Hearing Protection	1
15	R1057	Decal / 2" x 4" Red Reflector	2
16*	C0026	Grass Deflector	1
17	B0676	Hinge Stop Pl.	1

# Unit Model #: 49120908 (629JH-001A)

Mower: Country Clipper

Owner's Manual: Q0521

Mower Type: XLT

Deck Size: 48" & 54"

Vac Type: P2B+

Deck Type:

Drive Type: PTO-R

Revision #: 0

Fits Year(s): 2018-Newer



**A2155 Vac Kit**

- (1) A2101 Top Assy
- (1) HB0705 Vac Kit Hardware Bag
- (1) F0060 6" x 18" Upper Hose
- (1) V0025 6" & 7" Plastic Inlet
- (1) F0060 6" x 36" Lower Hose
- (2) B0227 Bag Ring
- (2) G0003 4 Cu. Ft. Collection Bags
- (2) B0752 Lwr. Mt. Tubes (29")
- (4) J0060 6" Hose Clamp

**A2156 Mount Kit**

- (1) B1042 Left PTO Mount Plate
- (1) B1041 Right PTO Mount Plate
- (1) B1040 Frame Strap
- (1) B1037 Left Frame Bracket
- (1) B1035 Rear Frame Bracket
- (1) B1036 Right Frame Bracket
- (1) V0016 6" Blower Cone
- (1) A2154 Drive Assy. w/ 3-Blade Impeller
- (1) HB0707 Engine Pulley Hardware Bag
- (1) M0239 A56K Belt

**A2037 Boot Kit**

- (1) V0049 Plastic Boot
- (2) B0922 Boot Plate Fasteners
- (1) B0921 Rear Boot Plate
- (1) HB0656 Boot Kit Hardware Bag
- (1) B0920 Front Boot Plate

**A2157 Single Weight Kit/ Single Caster**

- (1) Y0025 28 lb. Weight
- (1) HB0687 Hardware Bag
- (1) B1015 Weight Bracket
- (1) B1014 Dual Weight Bracket Base

**A2157 Single Weight Kit/ Single Caster**

- (1) Y0025 28 lb. Weight
- (1) HB0687 Hardware Bag
- (1) B1015 Weight Bracket
- (1) B1014 Dual Weight Bracket Base

## SAFETY DECALS

To promote safe operation, New PECO, Inc. supplies safety decals on all products manufactured. Damage can occur to safety decals either through shipment, use or reconditioning. Contact your local Service Center for replacement decals.



Part# R1070  
PECO Logo



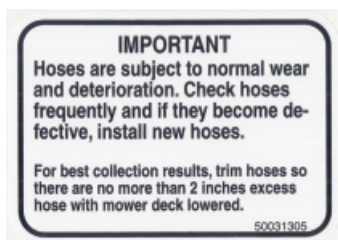
Part# R0022  
Designed & Built  
In The USA



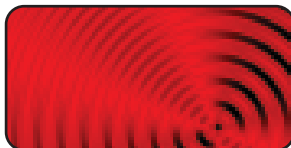
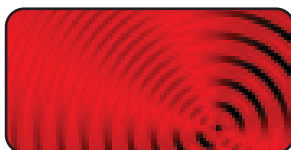
Part #: R2007  
Danger - Never Use Hands



Part #: R2008  
Danger - Rotating Blades



Part #: R1054  
Important - Hose Wear



Part #: R1057 - (2)  
Red Reflectors



Part #: R1069  
Warning - Turn Off Blower



Part # R0024  
Danger - Keep Hands  
Clear



Part #: R1051  
Warning - Hearing Protection



Part # R0025  
Danger - Rotating  
Blades

## SECTION III OPERATING INSTRUCTIONS

### General Safety

Only qualified people familiar with this operator's manual and the mower's operator's manual should operate this machine.

### Operation And Tips On Mowing

- A. Perform BEFORE EACH USE the maintenance list referenced in Section IV.
- B. Start mower.
- C. With the mower at high idle speed, engage the mower deck.
- D. While seated in the operator's seat, move Bagger PTO switch to the on position. With the PTO assembly engaged, you can proceed to operate the control levers of the mower.

**NOTE:** If the collection system does not appear to be collecting the grass clippings, disengage the deck and PTO assembly, then, engage the parking brake and turn the mower off. Check upper and lower hoses for any clogs.

To obtain the maximum effectiveness from your collection system, the tips listed below should be followed:

- \* Watch your speed- Normal conditions will allow a speed of up to approximately 4 mph, but thick, heavy damp conditions will require reduced ground speed.
- \* Mow with sharp blades- A sharp blade cuts cleaner.
- \* Wet grass and leaves will decrease effectiveness and will increase horsepower requirements.
- \* Mow at higher cutting heights- Remove and mulch no more than 2" of grass length with each mowing. (Experts recommend not cutting off more than 1/3 of the grass blade length at any given time.)
- \* Mow twice, at different height settings, (high, then low), if grass is extra tall.
- \* Remember that horsepower requirements will vary with the mowing conditions such as type and height of turf grass, moisture content, amount of leaves, whether the terrain is flat or hilly, etc.

### Disengagement Of The PTO Assembly

- A. To disengage the PTO assembly, move Bagger PTO switch to the off position.

**WARNING:** The PTO assembly blades will continue to spin. DO NOT TOUCH the PTO assembly, pulleys, or the belt until the tractor is turned off. DO NOT adjust the belt tension until the mower is turned off. Refer to the Belt Installation section of the manual.

### Unloading The Collection System

**NOTE:** To determine when the collection bags are full, follow the following steps:

- A. Stop the forward movement of the mower.
- B. Disengage the mower deck.
- C. Disengage the PTO assembly.
- D. Engage the parking brake.
- E. Once the parking brake has been engaged, then and only then, walk behind the mower and check the collection bags by first unhooking the rubber strap with S-hook that secures the plastic top, then lift the plastic hood. Load in bags should not exceed the height of the installed bag.
- F. To remove the bags from the frame, slide bags out and turn bags over to deposit clippings.
- G. Slide empty bags back onto the frame and secure plastic top with the rubber strap with S-hook.

**NOTE:** Do not allow collection bags to become over-filled as potential damage may occur to your equipment. Also, be sure to clean the hood screen as needed.

## SECTION IV MAINTENANCE

### Maintenance Checklist

Before each use:

1. Check blades and spindles to be sure that no foreign objects, such as wire or steel strapping bands, are wrapped around them.
2. Inspect blades for wear. Replace if necessary. If it is necessary to sharpen the blades, remove the blades from the spindles before sharpening. DO NOT sharpen blades while still attached to the mower.



3. Make sure all shields are in place and in good condition. Repair or replace any missing or damaged shields.
4. Perform lubrication per instructions.
5. Listen for abnormal sounds, which might indicate loose parts, damaged bearings, or other damage. Correct any deficiency before continuing operation.
6. With the engine off, engage the blower assembly. Check the belt tension and inspect the pulley belt for cracks or tears.
7. Check for wear or deterioration of the upper or lower hoses. If there are any portions of the hose that have been torn or worn through, replace immediately.

After Each Use:

1. Clean all debris from machine especially from the container, underneath the belt shields, and safety decals. Replace any missing or illegible decals.
2. Inspect the unit for worn or damaged components. Repair or replace before the next use. Any replacement component installed during repair shall include the component's current safety decal specified by the manufacturers to be affixed to the component.
3. Under normal usage, the bag material is subject to deterioration and wear and should therefore be frequently checked for necessary replacement. Any replacement bag should be checked to ensure compliance with the original manufacturer's recommendations or specifications.
4. Check belt for proper tension.

## Lubrication

Gearbox:

1. Every 20 hours of use: Check oil levels in gearbox.
2. First 60 hours of use: Change oil.
3. Every 100 hours of use: Change oil.

**NOTE:** Oil in gearbox should cover the gears. If not, drain the gearbox and fill using an 80W-90 gear oil. The gearbox ships with 6.0 oz. of oil, but we recommend replacing with a measured 5.5 oz. to fill the gearbox. **DO NOT OVERFILL!**

Blower Assembly:

**NOTE:** The following is for older PTO models that contain a greaseable zerc fitting. Newer models contain maintenance-free bearings and are without a greasable fitting.

1. On initial use: Grease the fitting on the blower shaft.
2. Every 25 hours of use: Re-grease the grease fitting.

**NOTE:** Use only white lithium based grease for lubrication of the shaft on the blower assembly.

## SECTION V - PARTS & SERVICE

### Parts And Service Information

Collection system owners should record the name and telephone number of their Service Center. Your Service Center will be happy to supply replacement parts, accessories, and do any service or repairs to your collection system. If for any reason your Service Center is unable to service your collection system or supply replacement parts, contact New PECO, Inc. and include the following information on the chart below.

### DOCUMENT THE FOLLOWING INFORMATION FOR FUTURE REFERENCE

**Unit Model Number:** \_\_\_\_\_

**Unit Engine Size:** \_\_\_\_\_

**Unit Serial Number:** \_\_\_\_\_

**Date of purchase:** \_\_\_\_ / \_\_\_\_ / \_\_\_\_

**Dealer/Distributor Name:** \_\_\_\_\_

**Address:** \_\_\_\_\_ **State:** \_\_\_\_\_ **Zip:** \_\_\_\_\_

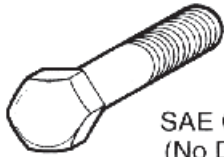
**Phone Number:** \_\_\_\_\_

**New PECO, Inc.**  
**10 Walden Dr | Arden, North Carolina 28704**  
**Phone: 1-800-438-5823 | 828-684-1234**  
**Fax: 828-684-0858**  
**Email: [peco@lawnvac.com](mailto:peco@lawnvac.com)**  
**Website: [www.lawnvac.com](http://www.lawnvac.com)**

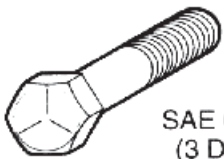
# TORQUE SPECIFICATIONS

Proper torque for American fasteners used on PECO equipment.  
Recommended Torque in Foot Pounds (Newton Meters).\*

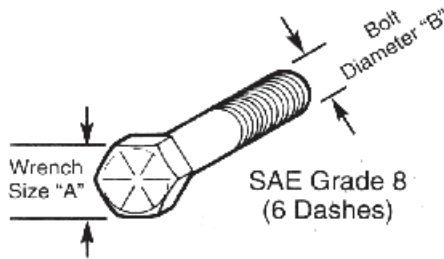
## AMERICAN Bolt Head Markings



SAE Grade 2  
(No Dashes)



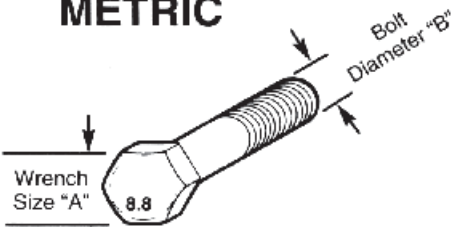
SAE Grade 5  
(3 Dashes)



SAE Grade 8  
(6 Dashes)

WRENCH SIZE (IN.) "A"	BOLT DIAMETER (IN.) "B" AND THREAD SIZE	SAE GRADE 2	SAE GRADE 5	SAE GRADE 8
7/16	1/4 - 20 UNC	6 (7)	8 (11)	12 (16)
7/16	1/4 - 28 UNF	6 (8)	10 (13)	14 (18)
1/2	5/16 - 18 UNC	11 (15)	17 (23)	25 (33)
1/2	5/16 - 24 UNF	13 (17)	19 (26)	27 (37)
9/16	3/8 - 16 UNC	20 (27)	31 (42)	44 (60)
9/16	3/8 - 24 UNF	23 (31)	35 (47)	49 (66)
5/8	7/16 - 14 UNC	32 (43)	49 (66)	70 (95)
5/8	7/16 - 20 UNF	36 (49)	55 (75)	78 (106)
3/4	1/2 - 13 UNC	49 (66)	76 (103)	106 (144)
3/4	1/2 - 20 UNF	55 (75)	85 (115)	120 (163)
7/8	9/16 - 12 UNC	70 (95)	109 (148)	153 (207)
7/8	9/16 - 18 UNF	79 (107)	122 (165)	172 (233)
15/16	5/8 - 11 UNC	97 (131)	150 (203)	212 (287)
15/16	5/8 - 18 UNF	110 (149)	170 (230)	240 (325)
1-1/8	3/4 - 10 UNC	144 (195)	266 (360)	376 (509)
1-1/8	3/4 - 16 UNF	192 (260)	297 (402)	420 (569)
1-5/16	7/8 - 9 UNC	166 (225)	430 (583)	606 (821)
1-5/16	7/8 - 14 UNF	184 (249)	474 (642)	668 (905)
1-1/2	1 - 8 UNC	250 (339)	644 (873)	909 (1232)
1-1/2	1 - 12 UNF	274 (371)	705 (955)	995 (1348)
1-1/2	1 - 14 UNF	280 (379)	721 (977)	1019 (1381)
1-11/16	1-1/8 - 7 UNC	354 (480)	795 (1077)	1288(1745)
1-11/16	1-1/8 - 12 UNF	397 (538)	890 (1206)	1444 (1957)
1-7/8	1-1/4 - 7 UNC	500 (678)	1120 (1518)	1817 (2462)
1-7/8	1-1/4 - 12 UNF	553 (749)	1241 (1682)	2013 (2728)
2-1/16	1-3/8 - 6 UNC	655 (887)	1470 (1992)	2382 (3228)
2-1/16	1-3/8 - 12 UNF	746 (1011)	1672 (2266)	2712 (3675)
2-1/4	1-1/2 - 6 UNC	870 (1179)	1950 (2642)	3161 (4283)
2-1/4	1-1/2 - 12 UNF	979 (1327)	2194 (2973)	3557 (4820)

## METRIC



Numbers appearing on bolt heads indicate ASTM class.

Proper torque for metric fasteners used on PECO equipment.  
Recommended torque in foot pounds (newton Meters).\*

WRENCH SIZE (mm) "A"	BOLT DIA. (mm) "B"	ASTM 4.6	ASTM 8.8	ASTM 9.8	ASTM 10.9
8	5	1.8 (2.4)		5.1 (6.9)	6.5 (8.8)
10	6	3 (4)		8.7 (12)	11.1 (15)
13	8	7.3 (10)		21.1 (29)	27 (37)
16	10	14.5 (20)		42 (57)	53 (72)
18	12	25 (34)	74 (100)	73 (99)	93 (126)
21	14	40 (54)	118 (160)	116 (157)	148 (201)
24	16	62 (84)	167 (226)	181 (245)	230 (312)
30	20	122 (165)	325 (440)		449 (608)
33	22		443 (600)		611 (828)
36	24	211 (286)	563 (763)		778 (1054)
41	27		821 (1112)		1138 (1542)
46	30	418 (568)	1119 (1516)		1547 (2096)

\*Use 75% of the specified torque value for plated fasteners. Use 85% of the specified torque values for lubricated fasteners.

# Troubleshooting

2017 (v1.0)

## Collection System Performance

<b>Problem</b>	<b>Possible Cause</b>	<b>Corrective Action</b>
Abnormal Vibration	<ul style="list-style-type: none"> <li>• Cutting blades are bent or unbalanced</li> <li>• Loose blower pulley or pulley assembly</li> <li>• Impeller blade out of balance</li> </ul>	<ul style="list-style-type: none"> <li>• Install new cutting blade</li> <li>• Tighten the pulley</li> <li>• Contact dealer to replace</li> </ul>
Reduced collection system performance	<ul style="list-style-type: none"> <li>• Low engine speed</li> <li>• Plugged screen</li> <li>• Loose belt</li> <li>• Full collection bags</li> </ul>	<ul style="list-style-type: none"> <li>• Always operate collection system at full throttle</li> <li>• Remove debris, leaves, or grass clippings from the screen</li> <li>• Replace/tighten belt</li> <li>• Empty the collection bags</li> </ul>
Blower and hoses plugging too frequently	<ul style="list-style-type: none"> <li>• Collection bags are too full</li> <li>• Low engine speed</li> <li>• Grass is too wet</li> <li>• Grass is too long</li> <li>• Ground speed is too fast</li> <li>• Worn belt</li> <li>• Loose belt</li> </ul>	<ul style="list-style-type: none"> <li>• Dump more frequently</li> <li>• Always operate collection system at full throttle</li> <li>• Cut grass when it is dry</li> <li>• Cut the grass several times</li> <li>• Drive slower at full throttle</li> <li>• Replace belt</li> <li>• Adjust the pulley and tighten belts</li> </ul>
Debris blowout	<ul style="list-style-type: none"> <li>• Collection bags are too full</li> <li>• Plug/clog in the collection system</li> <li>• Ground speed is too fast</li> </ul>	<ul style="list-style-type: none"> <li>• Dump more frequently</li> <li>• Clean the collection system</li> <li>• Drive more slowly at full throttle</li> </ul>
Impeller doesn't rotate freely	<ul style="list-style-type: none"> <li>• Plug in the blower housing</li> <li>• Worn impeller blade</li> <li>• Shaft bearings bad/failing</li> </ul>	<ul style="list-style-type: none"> <li>• Clean the blower housing</li> <li>• Contact dealer to replace</li> <li>• Contact dealer to replace</li> </ul>



**New PECO, Inc.**  
**10 Walden Dr | Arden, North Carolina 28704**  
**Phone: 1-800-438-5823 | 828-684-1234**  
**Fax: 828-684-0858**  
**Email: [peco@lawnvac.com](mailto:peco@lawnvac.com)**  
**Website: [www.lawnvac.com](http://www.lawnvac.com)**