

Cub Cadet®

PRO-X

DESIGNED
TO FIT:

POWER ASSIST TWIN BAG

MODEL YEAR:

2016-NEWER

Series:

PRO Z 100 L & S

- 48", 54" & 60" DECKS

COLLECTION SYSTEM

MODEL # 59A30046150

FOR SERIAL RANGE:

2E226XP0001 & UP

ALTERNATE

MODEL # 21120902



OPERATOR'S MANUAL

ASSEMBLY • OPERATION • MAINTENANCE

RESIDENTIAL BAGGING SYSTEM

TABLE OF CONTENTS

SECTION	PAGE	SECTION	PAGE
Safety	2	2-14 Lower Hose To Blower Cone Installation	13
Safety Alert Symbols	3	2-15 Lower Hose To Boot Installation	13
Warranty	4	2-16 Installation/Removal Of Collection Bags	14
I INTRODUCTION AND DESCRIPTION	5	2-17 Weight Kit Installation	15
1-1 Introduction	5	2-18 Safety Interlock Harness Installation	16-18
1-2 Description	5	Safety Interlock Harness Wiring Diagram	19
II INSTALLATION FOR USE	5	2-19 Impeller Blade Removal/Replacement	20
2-1 Preparation Of Mower	5	2-20 Even Bag Fill Adjustment	21
2-2 Mount Arm Preparation and Installation	6	Exploded Views & Parts List	22-30
2-3 PTO Drive Assembly	7-8	Pack Drawing	31
2-4 Drive Assembly and Belt Installation	9	Safety Decals	32
2-5 Lower Mount Tube Installation	10	III OPERATING INSTRUCTIONS	33
2-6 Upper Frame Assembly Installation	10	3-1 General Safety	33
2-7 Top Assembly to Upper Frame Assembly Installation	10	3-2 Operation & Tips On Mowing	33
2-8 Inlet Installation	10	3-3 Disengagement Of The PTO Assembly	33
2-9 Hinge Kit Installation	10	3-4 Unloading The Collection System	33
2-10 Blower Cone Installation	11	IV MAINTENANCE	33-34
2-11 Boot To Mower Deck Installation	12	4-1 Maintenance Checklist	33
2-12 Length of Hose Adjustment	13	4-2 Lubrication	34
2-13 Upper Hose Installation	13	V PARTS AND SERVICE	34
		5-1 Parts And Service Information	34
		Torque Specifications	35
		Troubleshooting	36
		Notes	37

SAFETY

1. Read the operator's manual carefully and familiarize yourself with the proper use of your attachment. Do not allow anyone who is not acquainted with the Safety Instructions to use your attachment.
2. Know the controls and how to stop them quickly. **READ THE OPERATOR'S MANUAL!**
3. Do not allow children to operate the machine. Do not allow adults to operate it without proper instruction.
4. Be especially watchful of children and pets entering into the area while operating.
5. Keep your eyes and mind on your machine while mowing or operating your attachment. Don't let others distract you.
6. Do not attempt to operate your machine when not in the driver's seat.
7. Always shut off blades and engine when emptying the container.
8. Stop machine, shut off deck attachment, set parking brake, shut off engine and remove ignition key before removing clogs, removing or replacing hose, boot, blower cone, or performing any maintenance.
9. Mow across the face of slopes (not more than 10 degrees); never up and down the face.
10. It is recommended that the container be emptied when half full while operating on slopes. Start mowing on slopes when the container is empty.
11. Inspect your lawn and remove any foreign objects before mowing. Never deliberately run the mower across any foreign object.
12. Wear hearing protection.
13. Wear eye protection to prevent debris from getting into your eyes.

SAFETY

WARNING! NEVER operate the mower unless the discharge guard and either the deflector assembly or the vacuum collector adapter are fastened securely in place.

WARNING! Do not work around the mower deck boot or the blower area until you are certain that the mower blades and the blower impeller have stopped rotating.

WARNING! To avoid serious injury, perform maintenance on the vacuum collector; **ONLY AFTER STOPPING THE MOWER'S ENGINE AND WAITING FOR ALL MOVING PARTS TO COME TO A COMPLETE STOP.** Set the parking brake. Always remove the ignition key before beginning maintenance.

WARNING! For your own personal safety, **ALWAYS mow ACROSS the face of slopes and NEVER UP and DOWN the face. NEVER attempt to mow excessively steep slopes, and use caution when turning on any slope.**

Safety Alert Symbol



This Safety Alert Symbol means: **“ATTENTION! BECOME ALERT! YOUR SAFETY IS INVOLVED!”**

This symbol is used to call attention to safety precautions that should be followed by the operator to avoid accidents. When you see this symbol, carefully read the message that follows and heed its advice. Failure to comply with safety precautions could result in death or serious bodily injury.

Safety Signs

The signal words **DANGER**, **WARNING**, and **CAUTION** are used on the equipment safety signs. These words are intended to alert the viewer to the existence and the degree of hazard seriousness.



White letters on **RED**

This signal word indicates a potentially hazardous situation which, if not avoided, will result in death or serious injury.



Black letters on **ORANGE**

This signal word indicates a potentially hazardous situation which, if not avoided, could result in death or serious injury.

It may also be used to alert against unsafe practices.



Black letters on **YELLOW**

This signal word indicates a potentially hazardous situation which, if not avoided, will result in minor or moderate injury.

It may also be used to alert against unsafe practices.

PECO LIMITED WARRANTY FOR NEW PRODUCTS

A. WHAT IS UNDER WARRANTY?

PECO extends the following warranties to the original purchaser of each new PECO consumer product subject to the following limitations.

- 1. PRODUCT WARRANTY:** Any part of any consumer product, which is defective in material or workmanship as delivered to the purchaser will be repaired or replaced, as PECO elects, without charge for parts or labor, if the defect appears within 12 months from the date of delivery of the product to the original purchaser. ALL DEFECTIVE PARTS MUST BE RETURNED TO PECO FOR INSPECTION TO DETERMINE VALIDITY OF WARRANTY CLAIMS. Freight and mailing will be borne by the customer.
- 2. PARTS REPLACED DURING WARRANTY:** Any new PECO part which is furnished in performance of this warranty and is defective in material or workmanship as delivered to the purchaser will be repaired or replaced, before the expiration of the original warranty period, whichever is later.
- 3. COMMERCIAL USE:** Products put to personal use around a single household or residence is considered 'Residential'; Products put to any business use (agricultural, commercial, or industrial) or used at multiple locations is considered 'Commercial.' Products designated as 'Commercial' are warrantied for 12 months from the date of delivery of the product to the original purchaser when used for in commercial applications. Products designated as 'Residential' are warrantied for 90 days from the date of delivery of the product to the original purchaser when in commercial applications.

B. SECURING WARRANTY ADJUSTMENTS

Call PECO for Return Authorization. Damaged or broken parts other than engines or batteries, must be returned to New PECO, Inc. at 10 Walden Drive, Arden, NC 28704 before any warranty adjustment can be authorized. At the time of requesting warranty adjustment, the purchaser must present evidence of the date of delivery of the product. The purchaser shall pay any charge for the product to and from Arden, NC.

C. ITEMS NOT COVERED BY PECO WARRANTY

Engines and batteries attached to PECO products are covered under a separate warranty by the respective manufacturer.

D. UNAPPROVED ALTERATION OR MODIFICATION

All obligations of New PECO, Inc. under this warranty shall be terminated if products are altered or modified in ways not approved by New PECO, Inc.

E. ACCIDENTS AND NORMAL MAINTENANCE

The warranty covers only defective material and workmanship. It does not cover depreciation or damage caused by normal wear, accident, improper use or abuse of products. The cost of normal maintenance and normal replacement of service items such as belts, cutting blades, hoses, etc., which are not defective shall be paid for by the purchaser.

F. NO REPRESENTATIONS ADDITIONAL WARRANTIES, DISCLAIMER

Neither New PECO, Inc. nor any company affiliated with it makes any warranties, representations or promises as to the quality of performance of its products other than those set forth herein. Except as described above, New PECO, Inc. makes no other warranties AND SPECIFICALLY DISCLAIMS ANY AND ALL IMPLIED WARRANTIES OF FITNESS AND MERCHANTABILITY.

G. PRODUCTS USED FOR RENTAL OR LEASE PURPOSES ARE WARRANTIED FOR 45 DAYS FROM DATE OF ORIGINAL SALE ONLY

H. REMEDIED EXCLUSIVE

The only remedies the purchaser has in connection with the breach or performance of any warranty on New PECO, Inc. consumer products are set forth above. In no event will PECO be liable for special incidental or consequential damages.

1. NO SERVICE CENTER WARRANTY

The selling Service Center makes no warranty on his own on any item warrantied by New PECO, Inc. unless he delivers to purchaser a separate written warranty certificate specifically warranting the item. The dealer has no authority to make any representation or promise on behalf of PECO or to modify the terms of this warranty in any way.

Section I - INTRODUCTION & DESCRIPTION

1-1 Introduction

Your grass collection system has been designed to give you a low maintenance, simple, and effective way to collect the grass clippings from your mower. This manual is provided to give you the necessary instructions to properly mount and operate the collection system on your mower. Please read this manual thoroughly. Understand what each control is for and how to use it. Observe all safety decal precautions on the machine and noted throughout the manual.

NOTE: All references made to right, left, front, rear, top or bottom are as viewed from the normal operator's position on the mower.

1-2 Description

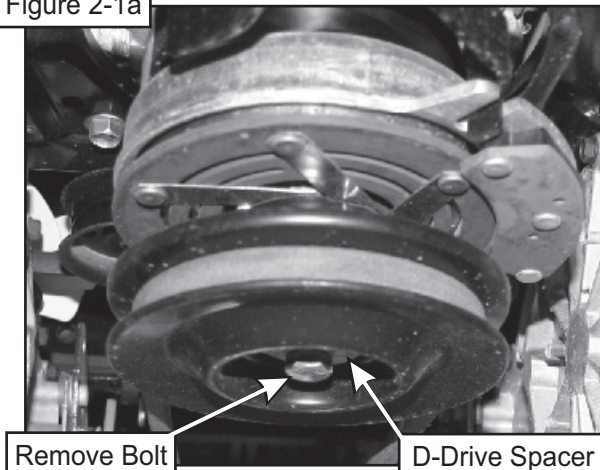
The grass collection system is designed for turf maintenance where there is a need to collect the grass clippings as the mower cuts the turf. It is also used for picking up leaves in pre-season and post-season clean-up. The blower, mounted on the right side of the unit, uses a belt and gearbox system from the engine PTO shaft. Drive train protection comes through belt slippage. The blower draws grass clippings from the discharge area of the cutting deck back to the (2) - 4 cubic foot collection bags P#(G0013-L) at the rear portion of the mower frame. The operator can engage the blower with a toggle switch mounted on the control panel to the right of the operator. Once the bags are full with clippings, they can be easily released for dumping.

Section II - INSTALLATION FOR USE

Collection System May Require Dealer Installation!

Please refer to Page 17 for further details.

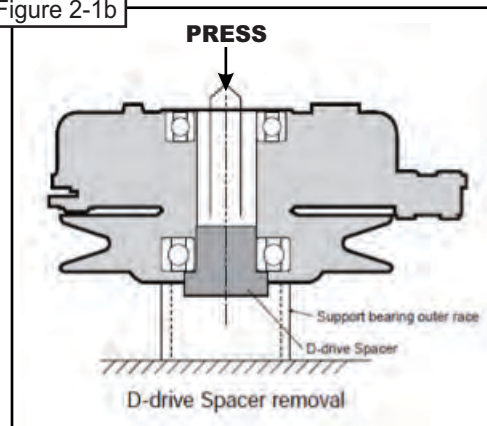
Figure 2-1a



2-1 Preparation Of Mower

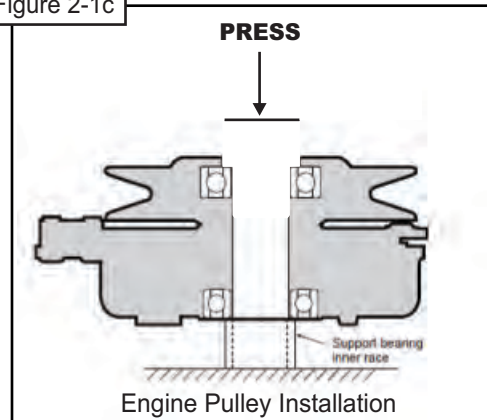
From the underside of the engine, disconnect the wiring harness attached to the electric clutch. Remove the bolt and electric clutch from the mower. Refer to Figure 2-1a. Remove the D-drive spacer using an arbor press or equivalent. On removal, adjacent bearing OUTER race must be supported or bearing damage may occur. Refer to Figure 2-1b.

Figure 2-1b



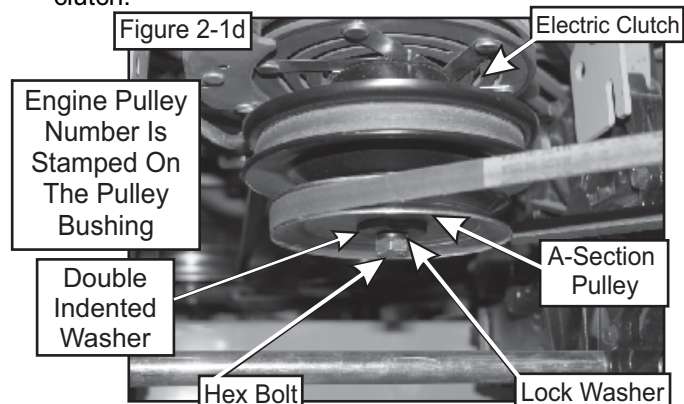
The engine pulley bushing #31 P#(S0220) may need to be installed using an arbor press or equivalent. If pressed, opposite bearing inner race must be supported or bearing damage may occur. Refer to Figure 2-1c.

Figure 2-1c



Fasten the A-Section Pulley P#(M0309) to the pulley bushing and electric clutch assembly using (1) 7/16" Double Indented Washer P#(K0278), (1) 7/16" hi-collar lock washer P#(K0140) and (1) 7/16"-20 x 5" HHCS P#(K0018) as shown in Figure 2-1d. The added pulley will power the collection system. Torque the bolt to 55 ft./lbs. Re-connect the wiring harness to the electric clutch.

Figure 2-1d



2-2 Mount Arm Preparation and Installation

Remove the (3) 1/2"-13 x 1-1/4" existing HHCS, (3) 1/2" washers and (3) 1/2"-13 Ny-Flange locknuts from the right-rear of the mower and save the 1/2" Flat Washers for the next step. Next, loosen bolts on opposite side of mower for rear bumper alignment in the next step. Refer to figure 2-2a.

Secure the Mount Arm Assembly P#(A2063_01) to the rear guard of the mower, using (3) 1/2"-13 x 1-3/4" HHCS GR5 P#(K1301), (3) 1/2" Flat Washers (retained previously), (3) 1/2"-13 Ny-Flange Lock Nuts P#(K2012), (4) 3/8"-16 x 1-1/4" HHCS GR5 P#(K1192), (4) 3/8" Flat Washers P#(K0047), and (4) 3/8"-16 Ny-Flange Lock Nuts P#(2038). Refer to figure 2-2b.

Important: Before tightening bolts (A) (Figure 2-2b), on both sides, make certain that the bumper is rotated fully in the upward position. Once drive is installed, Section 2-4, the correct distance from the center of the engine pulley to the center of the drive pulley is 34.84"(inches). If the dimension is within + or - .06, no further adjustment is necessary.

Figure 2-2a

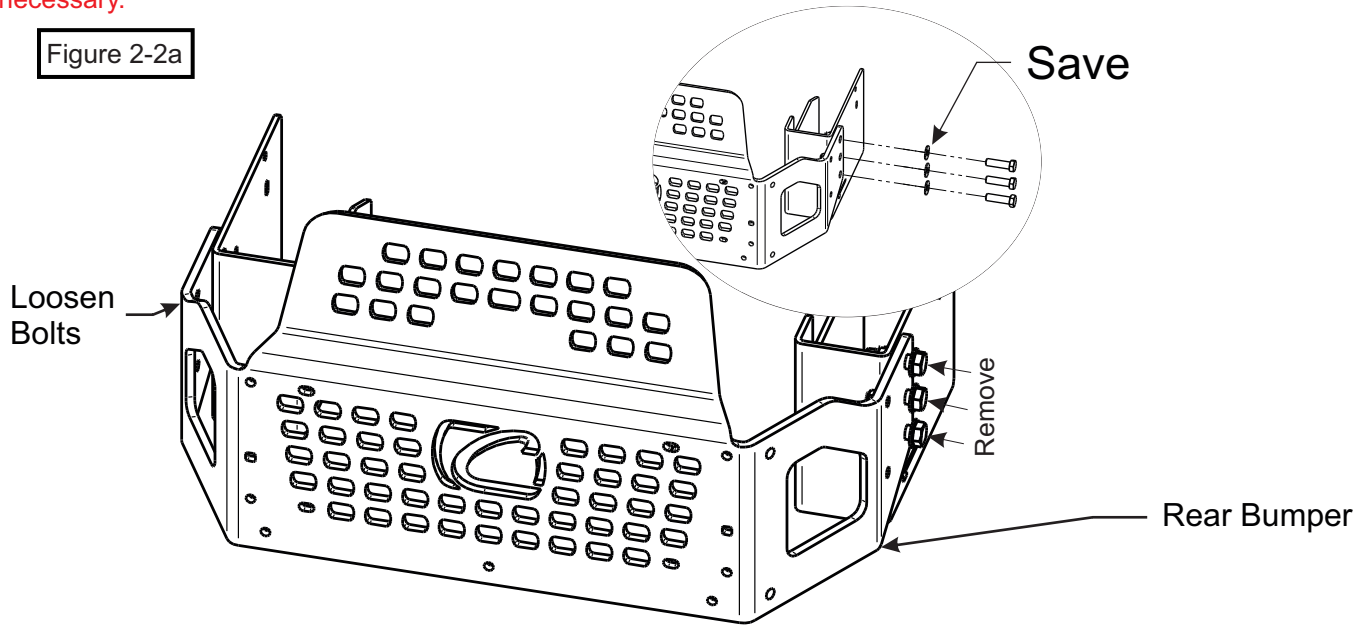
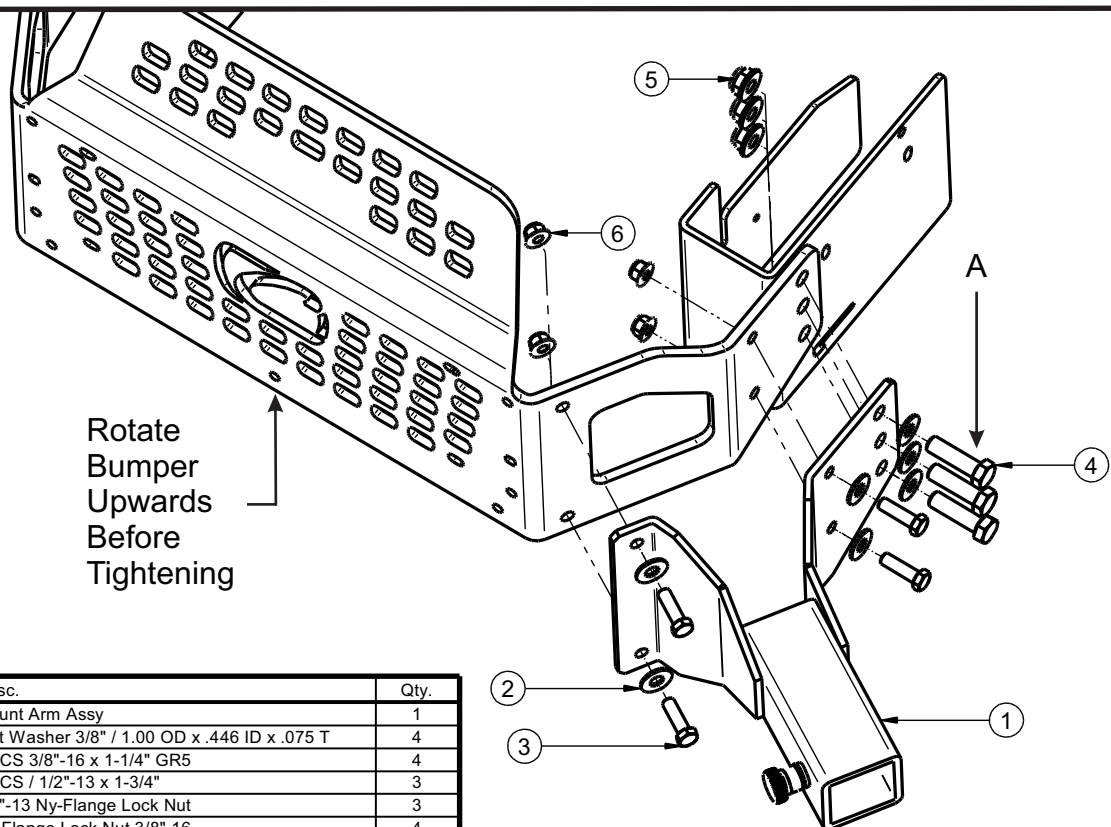


Figure 2-2b

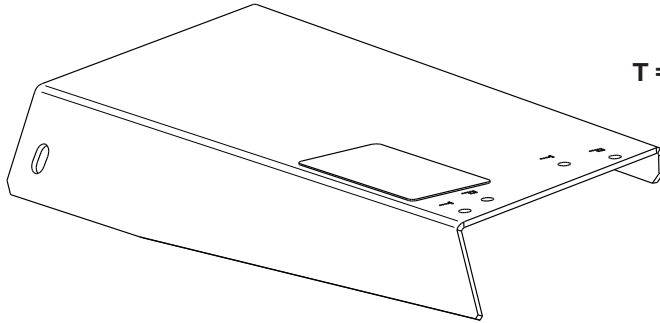


2-3 PTO Drive Assembly

Once the Mount Arm Assembly P#(A2063_01) is installed and secured to the mower, assemble the Drive Assembly P#(A2061_01), Belt Guard Assembly P#(A2069_02), and the Idler Mount Assembly P#(A2067_02).

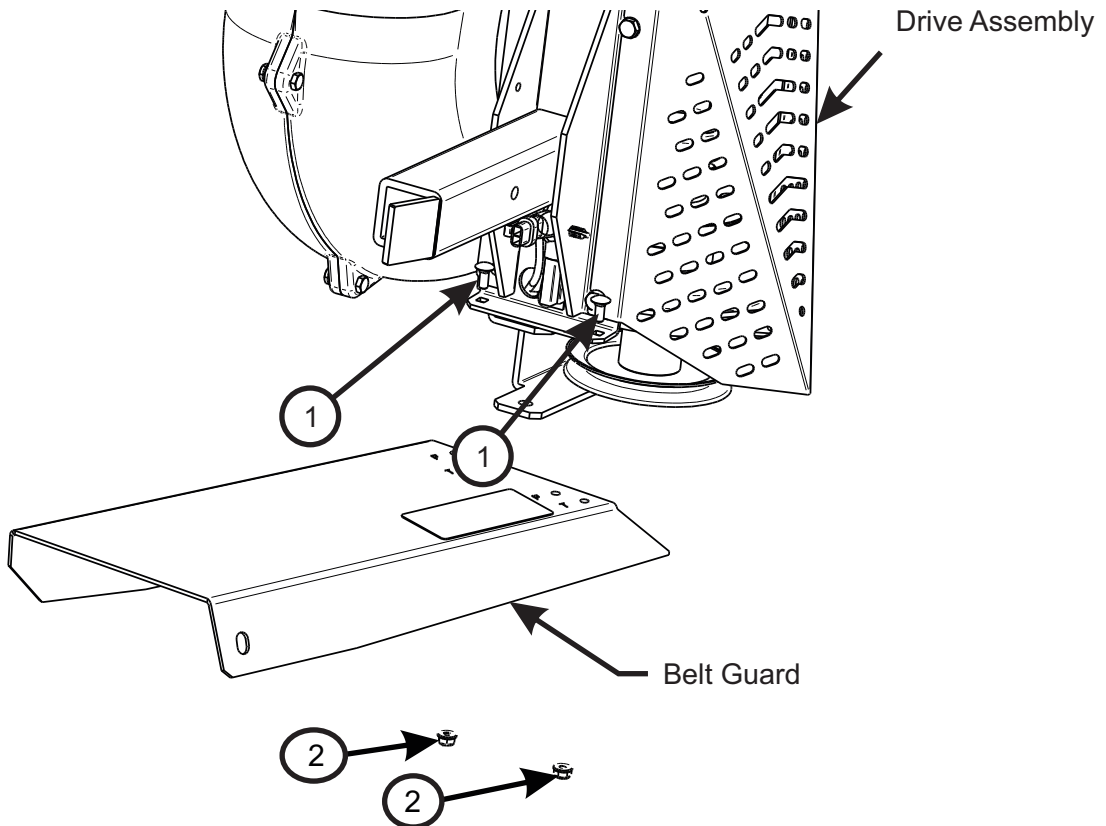
First, attach the Belt Guard Assembly P#(A2069_02) to the Drive Assembly P#(A2061_01) using (2) 1/4"-20 x 5/8" Carriage Bolts P#(K1010) and (2) 1/4"-20 Ny-Flange Lock Nuts P#(K2014). Refer to figure 2-3a. **Leave Bolts Loose.**

BELT GUARD ASSY.



Notice Marked Holes Below;
(Use corresponding holes with type of mower that is being fitted up)
T = Pro Z 500, 700 & 900 series Mounting Hole
P = Pro Z 100 series Mounting Hole

Figure 2-3a

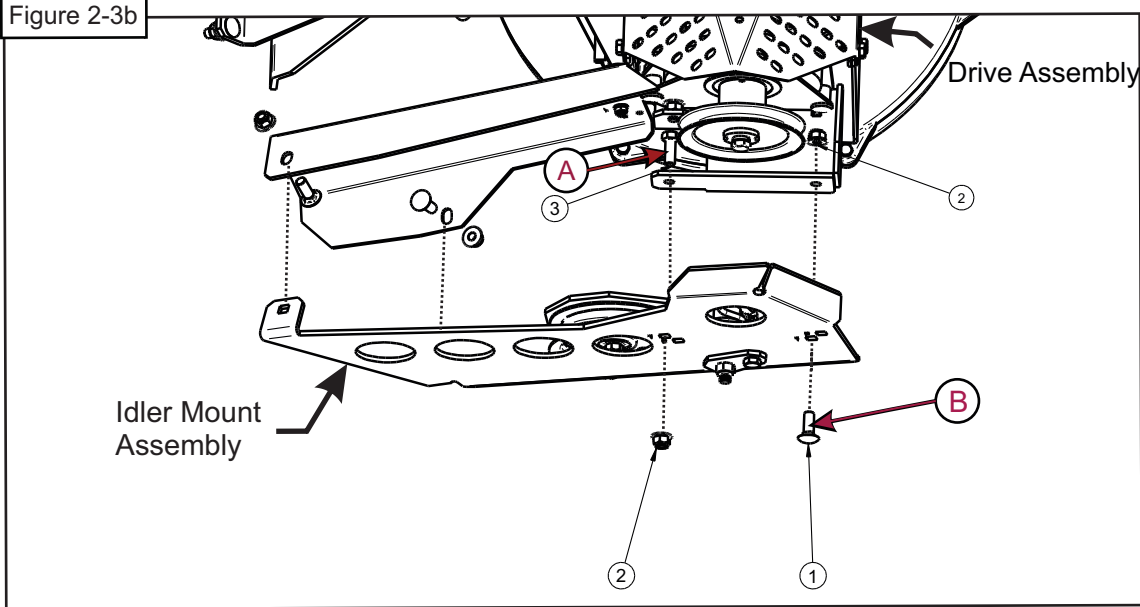


Item #	Part #	Desc.	Qty.
1	K1010	1/4"-20 x 5/8" Carriage Bolt	2
2	K2014	1/4"-20 Ny-Flange Lock Nut	2

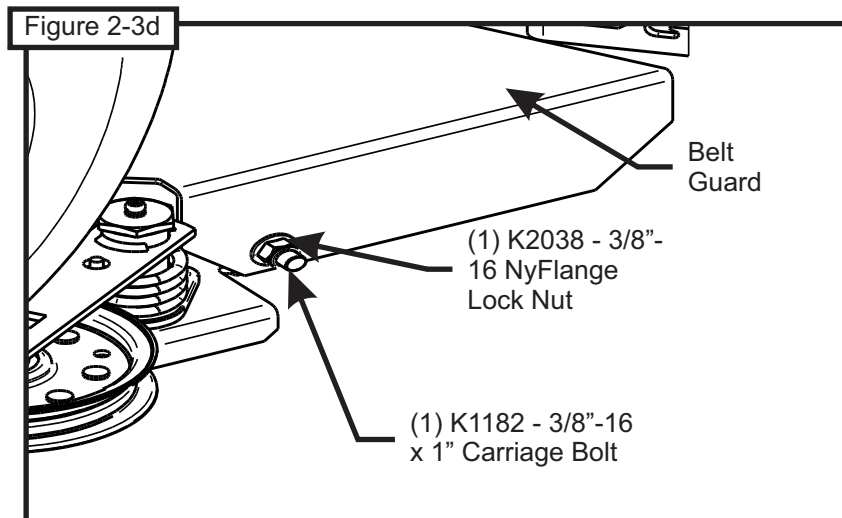
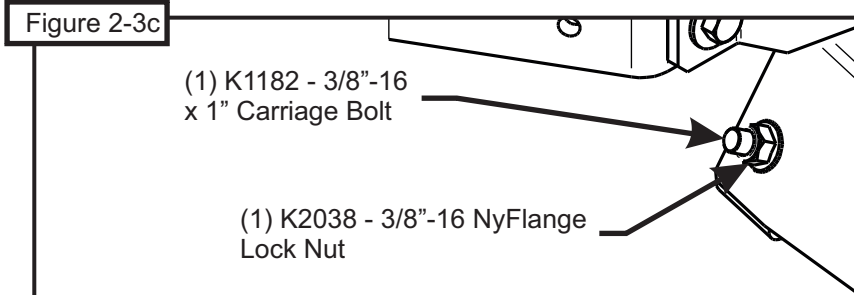
2-3 PTO Drive Assembly (Continued)

Attach the Idler Mount Assembly P#(A2067_02) to the Drive Assembly using (1) 3/8"-16 x 1" HHCS (A) P#(K1191), (1) 3/8"-16 x 1" Carriage Bolt (B) P#(K1182) and (2) 3/8"-16 Ny-Flange Lock Nuts P#(K2038). Refer to Figure 2-3b. Leave Bolts Loose (Note: Orientation of bolts A & B.)

Next, secure the Idler Mount Assembly P#(A2067_02) to the Belt Guard Assembly P#(A2069_02) using (2) 3/8"-16 x 1" Carriage Bolts P#(K1182) and (2) 3/8"-16 Ny-Flange Lock Nuts P#(K2038). Refer to Figure 2-3c & d. Tighten All Bolts.



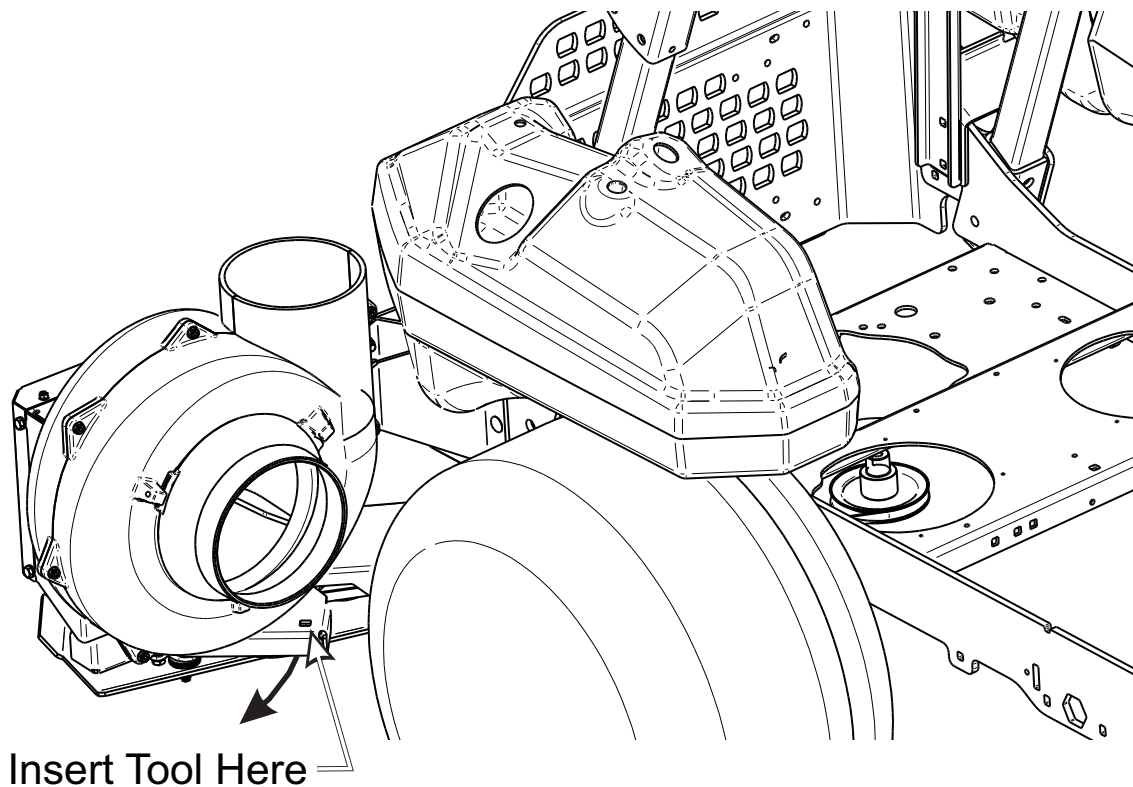
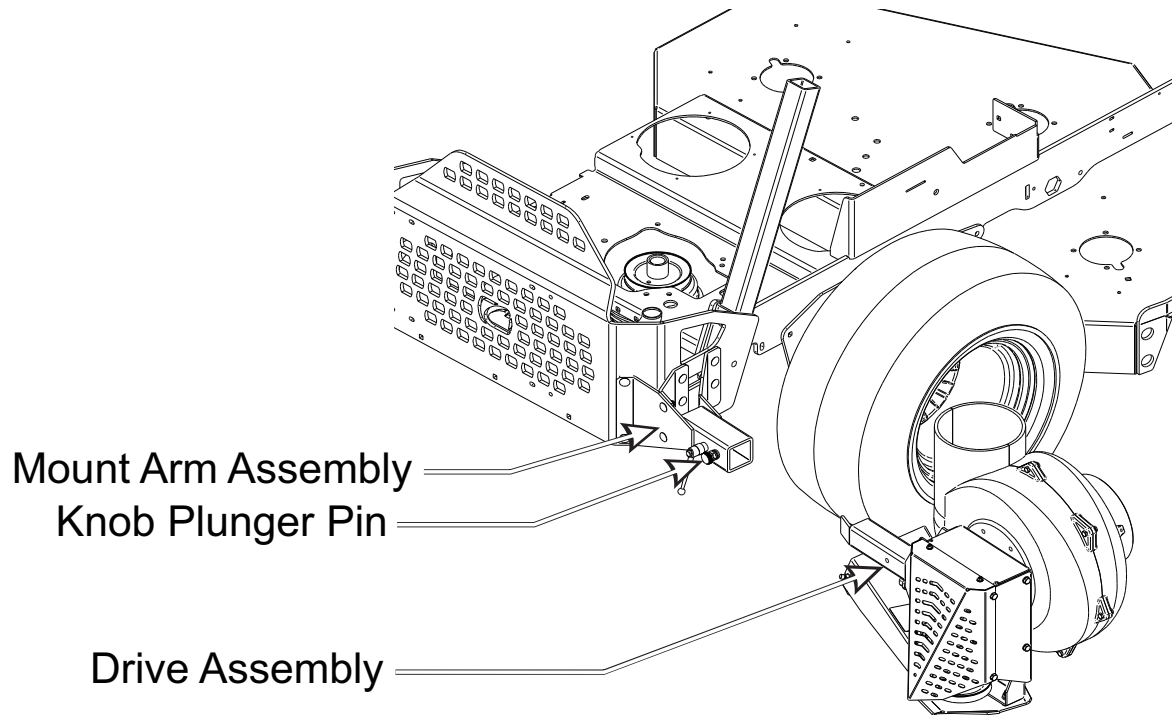
Item #	Part #	Desc.	Qty.
1	K1182	Carriage Bolt 3/8"-16 x 1"	1
2	K2038	Ny-Flange Lock Nut 3/8"-16	2
3	K1191	HHCS 3/8"-16 x 1" GR5	1



2-4 Drive Assembly and Belt Installation

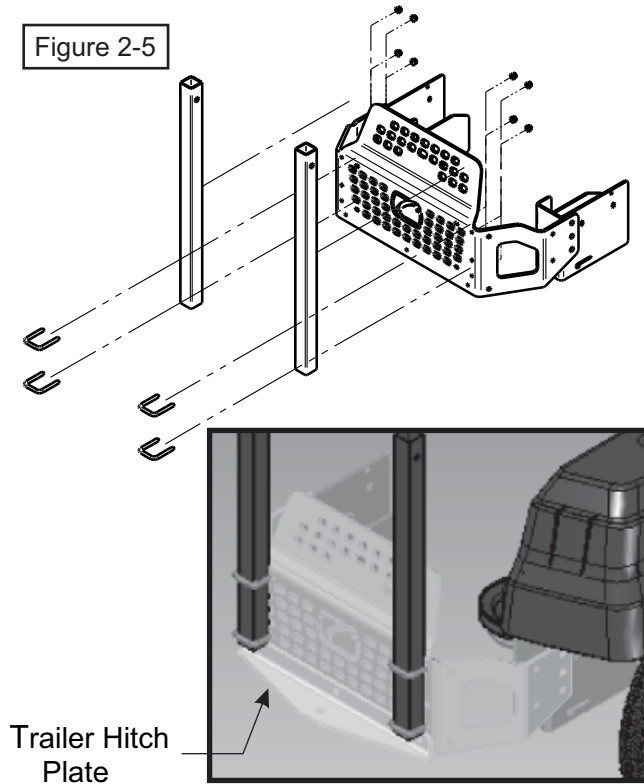
(Note: It is recommended that someone assist during this step.)

Insert the Drive Assembly into the receiver tube on the Mount Arm Assembly until the Knob Plunger Pin engages. Next, feed the AK82 Belt P#(M0311) between the Belt Guard and the Idler Mount Assembly. Place belt around the PTO pulley on the underside of the mower. While one person inserts a 1/2" drive tool (socket handle) into the Idler Mount Assembly and rotates lever arm clockwise, enough to relieve all tension from belt, place belt around the drive pulley. Once belt is in position, carefully release the tension to tighten belt.



2-5 Lower Mount Tube Installation

Secure the (2) lower mount tubes P#(B0752) to the rear frame using (2) 5/16"-18 u-bolts P#(K1098) and (4) 5/16"-18 nylon flange locknuts P#(K2516) PER TUBE. Refer to Figure 2-5. Note: Bottom of Tubes should rest on the top edge of the Trailer Hitch Plate.



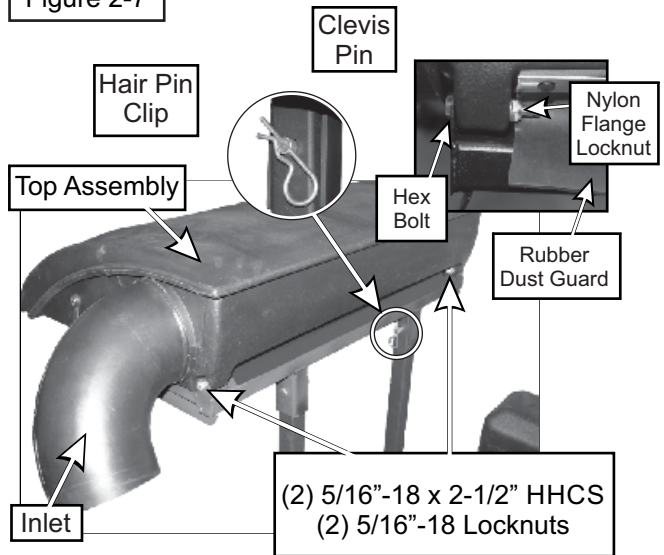
2-6 Upper Frame Assembly Installation

Lift the upper frame assembly P#(A2047) into position, and slide onto the lower mount tubes as shown in Figure 2-7 and secure with (2) 1/2" x 2-1/4" clevis pins P#(K0133) and (2) hair pin clips P#(K0088). **Note:** It is recommended that someone assist you when installing the upper frame assembly.

2-7 Top Assembly To Upper Frame Assembly Installation

Position the top assembly P#(A2110) above the upper frame assembly with the Rubber Dust Guard positioned towards the seat as shown in Figure 2-7. Fasten the top assembly to the upper frame assembly using (2) 5/16"-18 x 2-1/2" HHCS P#(K0125) and (2) 5/16"-18 nylon flange locknuts P#(K2516). Leave the locknuts slightly loose, to allow the top assembly to open and close easily. Refer to Figure 2-7 for hardware location.

Figure 2-7

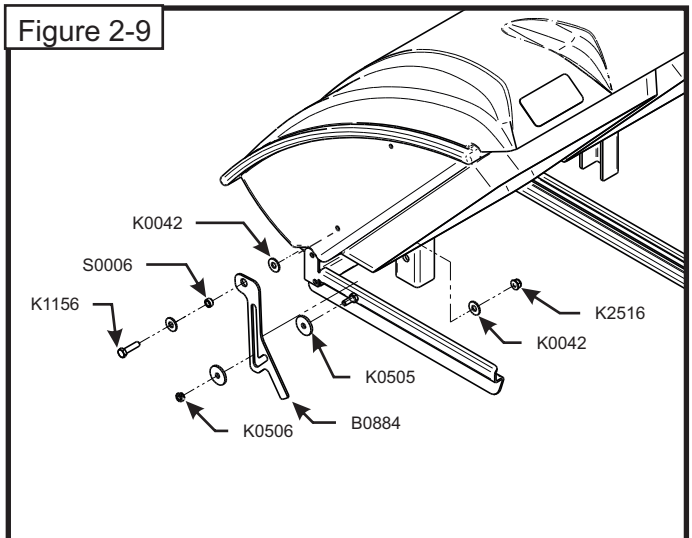


2-8 Inlet Installation

Insert the Inlet P#(A2111) into the hole on the top assembly from the inside and then snap the inlet into place. The inlet should pivot freely about the hole.

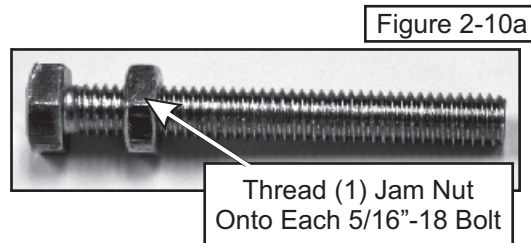
2-9 Hinge Kit Assembly Installation

Assemble the hinge kit as shown in Figure 2-9, using (1) Latch Plate P#(B0884), (1) 5/16"-18 x 1-1/4" HHCS P#(K1156), (1) 5/16"-18 Ny-Flange locknut P#(K2516), (3) 5/16" Flat Washers P#(K0042), (1) Latch Spacer P#(S0006), (2) Extra Heavy 5/16" Fender Washers P#(K0505) and (1) 5/16"-18 Lock Nut P#(K0506). Leave the nuts loose enough to allow fluid movement of the top when opening and closing. When opened, the top should rest in the Latch Plate Slot.

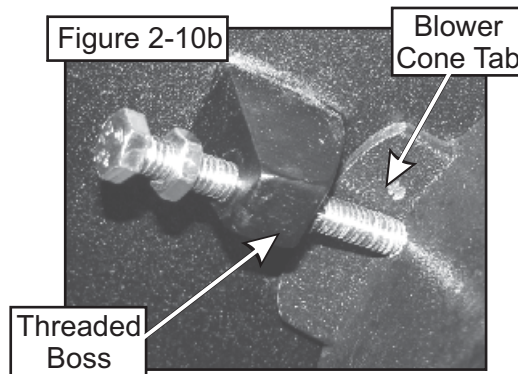


2-10 Blower Cone Installation

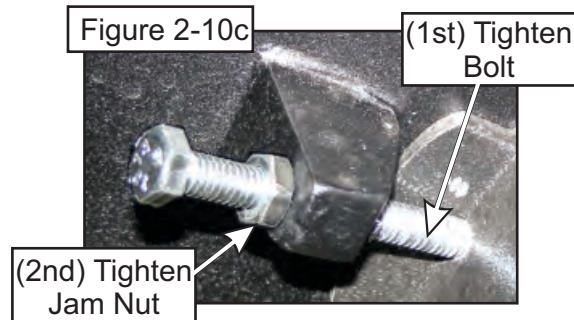
Thread (1) 5/16"-18 jam nut P#(K0120) onto each end of (2) 5/16"-18 x 2-1/2" HHCS P#(K0125) as shown in Figure 2-10a.



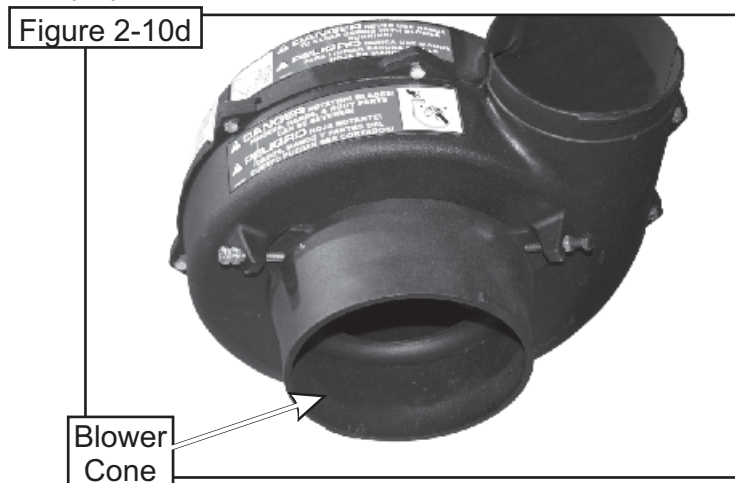
Now partially thread (1) bolt into each of the two threaded bosses located on the blower housing. Place 8" Blower Cone P#(E6009) so the two tabs line up with the bolts and tighten completely as shown in Figure 2-10b.



Once the (2) bolts are tight, tighten the jam nuts against the threaded boss as shown in Figure 2-10c.

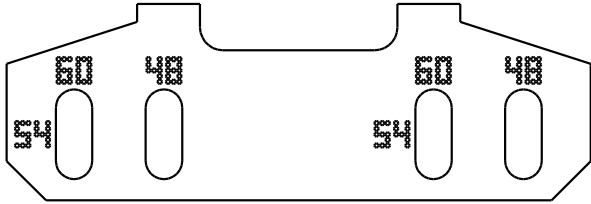


Refer to Figure 2-10d for proper blower cone installation reference.



2-11 Boot To Mower Deck Installation

NOTE: The boot kit assembly is designed to fit the 48", 54" and 60" deck. To ensure a snug fit between the boot and the mower deck, follow the instructions in this step thoroughly, and remove and tighten all hardware in the sequence specified.



According to deck size, align marked holes and Boot holes. Secure the boot mounting assembly P#(A2045) to the aluminum boot P#(E0028A) using (2) 3/8"-16 x 1" carriage bolts P#(K1182) and (2) 3/8"-16 nylon flange locknuts P#(K2038). Insert the carriage bolts from the inside of the boot so the threads are on the outside of the boot (Figure 2-11a). This will prevent grass clippings from collecting on the bolt threads. Leave bolts loose for alignment once installed on mower.

After removing only the wing knobs align the threaded mount posts, on the boot mounting assembly, with the mounting holes located above the mowers discharge chute and insert the into the mounting holes. Secure with the (2) Wing Knobs P#(J0018). Press Boot against discharge chute, to ensure a snug fit and tighten the two nuts on top of the boot. Refer to Figure 2-11b.

Note: Deflector not shown for clarity but must be installed during normal operation.

Figure 2-11a

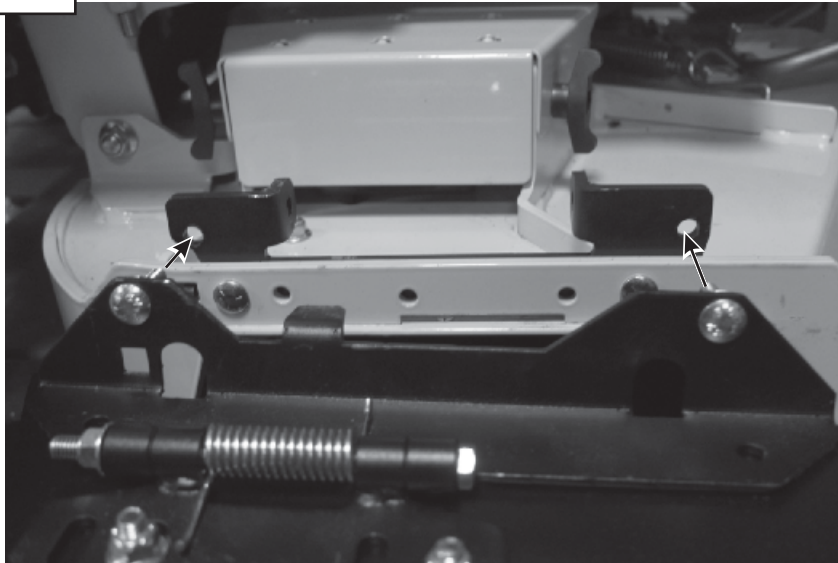
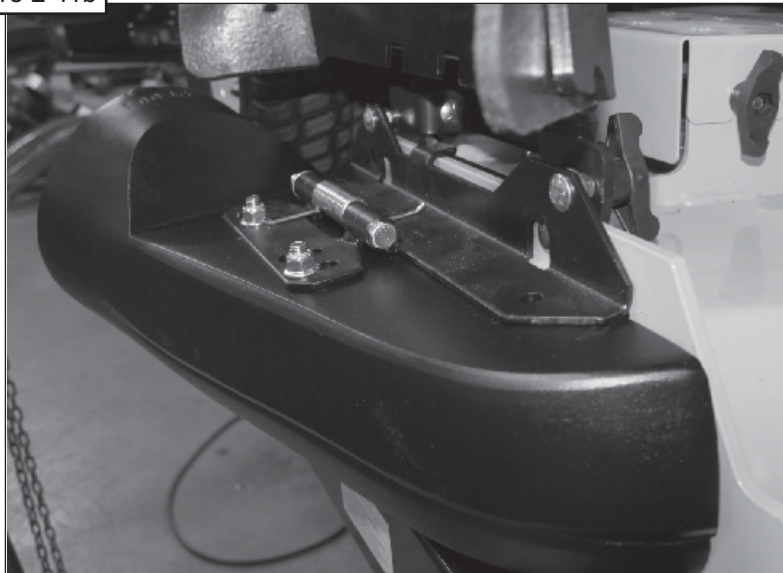


Figure 2-11b



2-12 Length Of Hose Adjustment

The hoses in steps 2-13 and 2-14 must be cut to fit your machine. Follow steps 2-13 and 2-14. do not cut the hoses until you have tried to fit them on your machine. Remember that the hoses have to be long enough to adjust for the blower assembly's movement as well as allow for enough clamping surface between the inlet, blower assembly, and the deck boot.

2-13 Upper Hose Installation

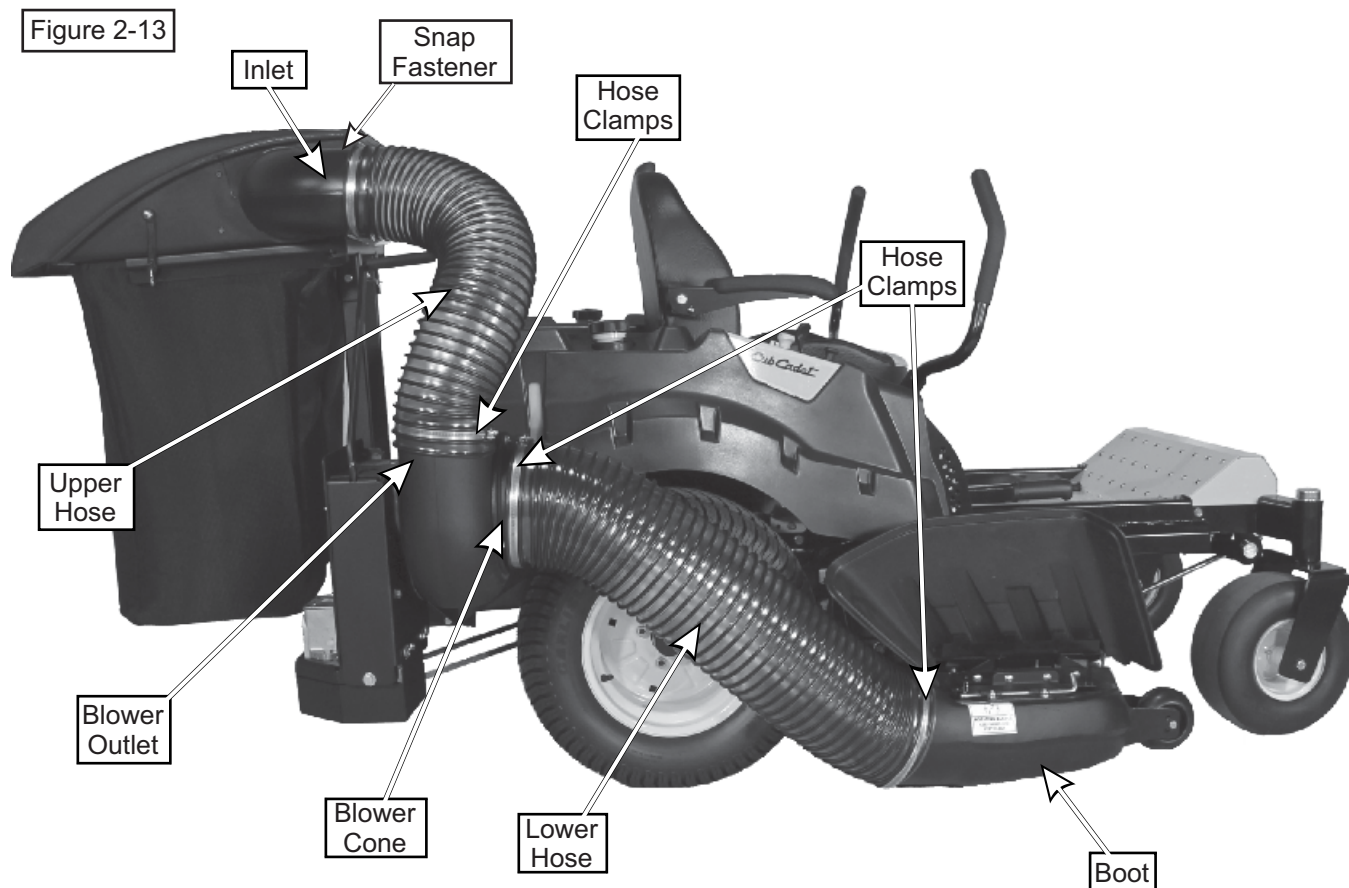
Fasten the inlet to the plastic top by sliding the inlet from the inside of the top to the outside and lock into place. Slide a hose clamp P#(J0060) onto one end of the 6" upper hose (Figure 2-13). Next, slide opposite end of the 6" hose onto the inlet. Make sure that the hose is in position to be secured by the Snap Fastener P#(K0508). Proceed to slide the opposite end of the 6" hose onto the outlet of the blower assembly. Make sure both ends of the hose are clearly attached to the inlet and the blower assembly inlet. Tighten the hose clamp.

2-14 Lower Hose To Blower Cone Installation

Slide a clamp P#(J0080) over both ends of the lower hose. Then proceed to slide the lower hose onto the blower cone. Tighten the hose clamp. The assembly should look like Figure 2-13.

2-15 Lower Hose To Boot Installation

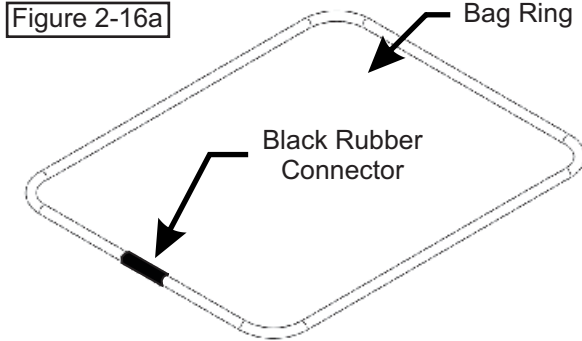
Take the unattached end of the lower hose and slide it over the circular end of the boot. Use the lower hose clamp to secure the hose to the boot (Figure 2-13). Tip: Before securing clamp rotate hose counter-clockwise (away from yourself) approximately 1" to aid in retaining boot to mower deck.



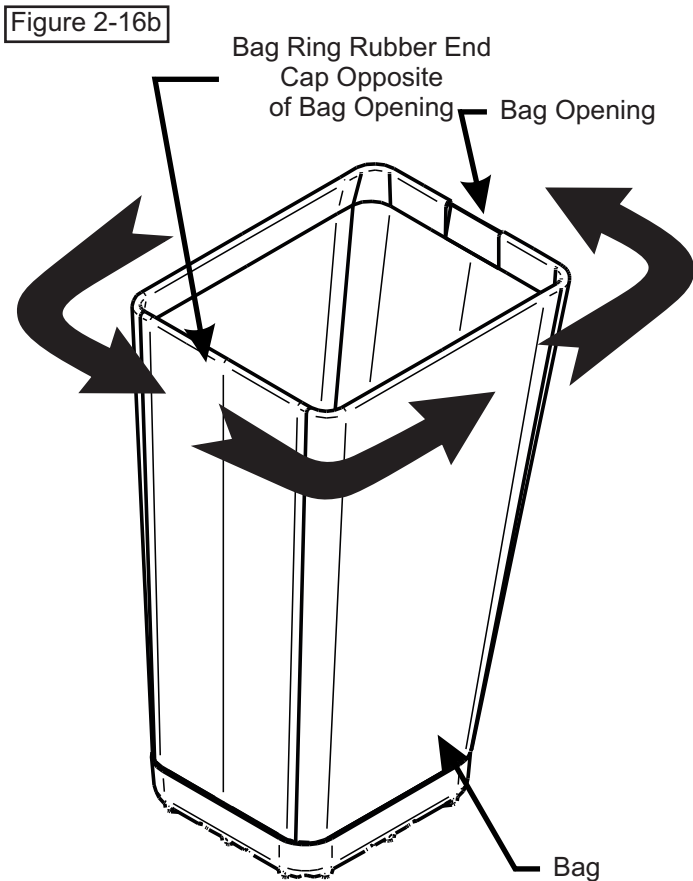
2-16 Installation/Removal Of Collection Bags

IMPORTANT!

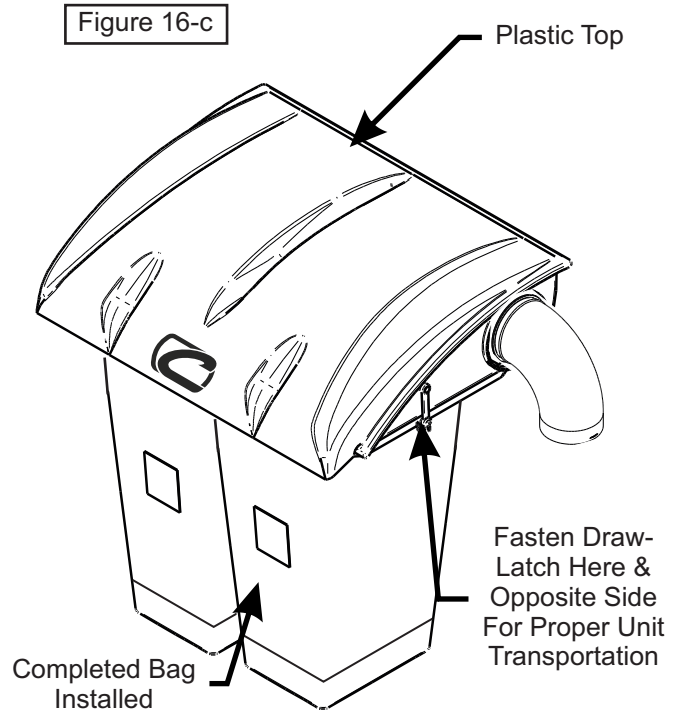
To prevent bag wear, install (1) black rubber end cap P#(F0010), as shown in Figure 2-16a, on each bag ring after rotating bag 360°.



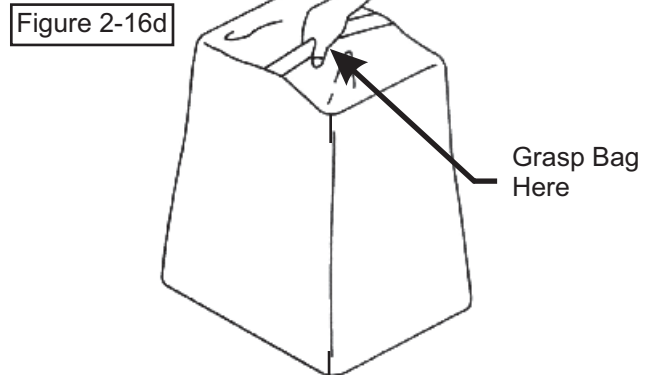
To complete the bag installation, place the seam openings of the bag and the bag ring openings together. Place the rubber bag ring connector on both ends of the bag ring and turn the bag one half turn (180°) so the rubber end cap is located opposite to the opening in the bag (Figure 2-16b). Do this for each bag.



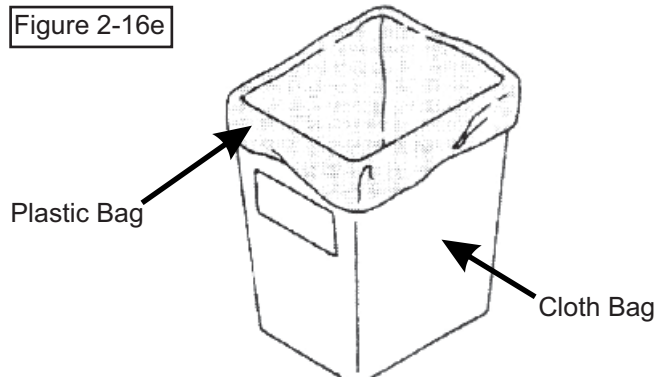
Install the completed assemblies onto the support frame and close the plastic top. Fasten the draw-latches to hold the plastic top closed (Figure 2-16c).



To empty the bag, first unlatch and lift top, next remove the bag and bag ring by sliding rearward, then grasp the handle on the bottom of the bag, and last turn it upside down to empty the collected debris (Figure 2-16d). Repeat for the other bag. Reinstall both bags, line with plastic bags if desired, close the plastic top and reattach the draw latches.



Plastic lawn and leaf bags, 33 gallon size, may be used inside the cloth bags. Be sure to leave enough plastic bag hanging over the frame so the plastic bags can be twist tied before emptying (Figure 2-16e).



2-17 Weight Kit Installation

Note:

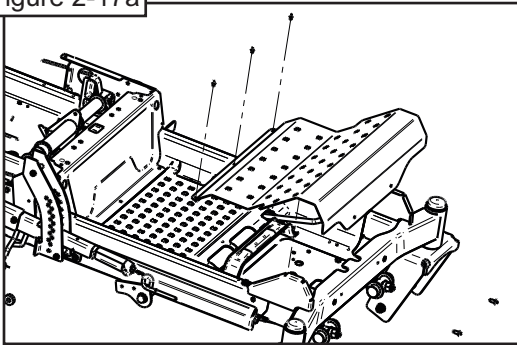
- Installing a weight kit is mandatory for safe operation of the collection system.
- When installing the weight bar, you should have another person to help position the weight.
- If removing PTO assembly for side-discharge mowing, please also remove the weight kit.



Installation:

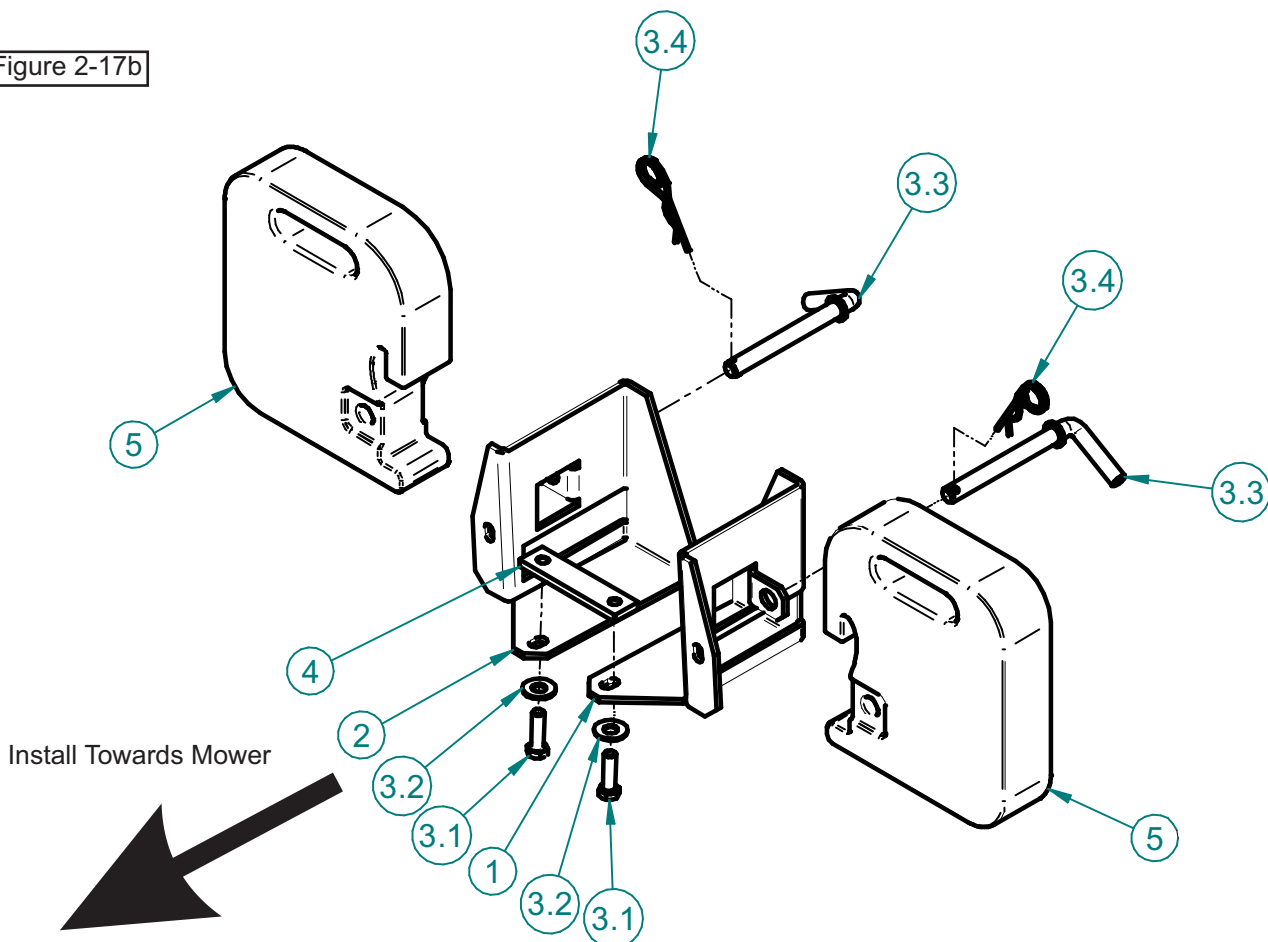
To install weight kit, first remove screws on foot rest panel and retain. Next, remove and discard the HHCS on the under side of the front of the mower. Lift the foot rest panel to access the front frame compartment. Refer to Figure 2-17a. Place Weight Bar Clamp P#(B0943), as shown in Figure 2-17b and loosely attach both the Right Mount Plate P#(B1009) & Left Mount Plate P#(B1010) with (1) 3/8"-16 x 1-1/4" HHCS P#(K1192) and (1) 3/8" Flat Washer P#(K0047) each. Lower the foot rest panel and loosely attach the front of both of the mount plates with the torx screws removed earlier. Replace the remaining foot rest screws and tighten all bolts installed. Attach (1) weight P#(Y0025) per bracket as shown in Figure 2-17b. Fasten each side using (1) Hitch Pin P#(A0312) and (1) Hair Pin Cotter P#(K1478).

Figure 2-17a

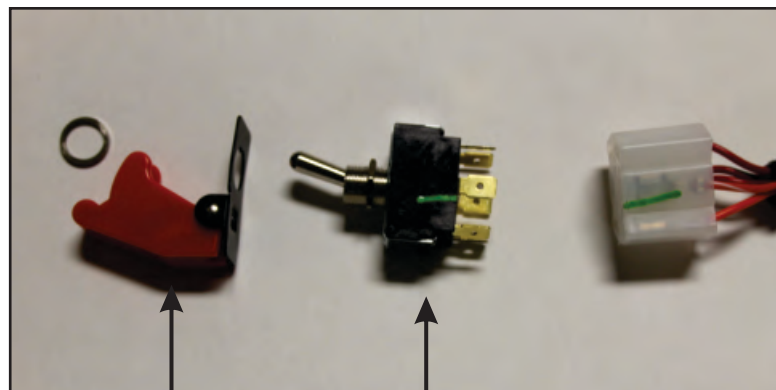
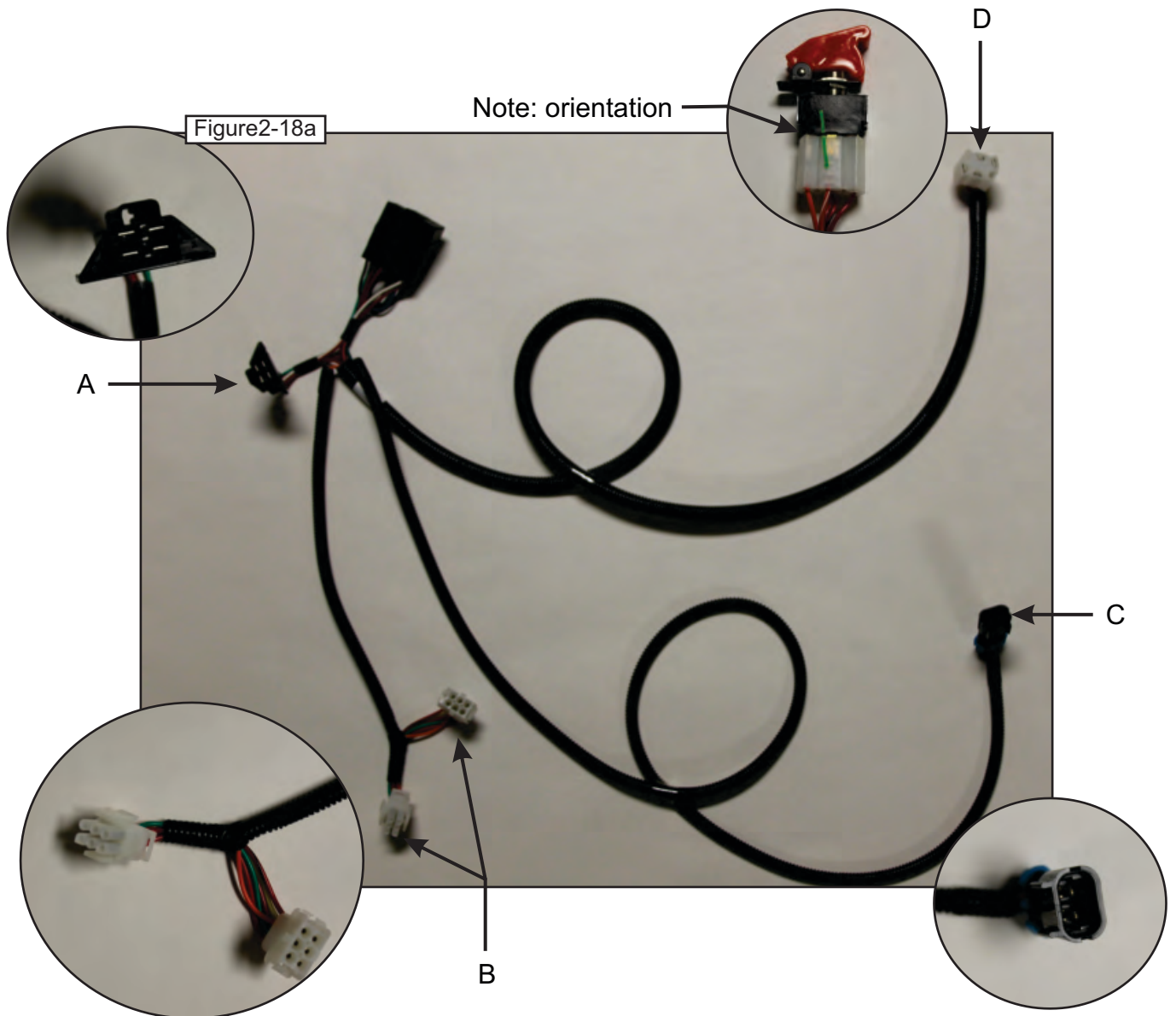


Item #	Part #	Desc.	Qty.
1	B1009	Right Mount Plate / Weight Kit	1
2	B1010	Left Mount Plate / Weight Kit	1
3	HB0658_01	HW Bag / Weight Kit	1
3.1	K1192	HHCS 3/8"-16 x 1-1/4" GR5	2
3.2	K0047	Flat Washer 3/8" / 1.00 OD x .446 ID x .075 T	2
3.3	A0312	Hitch Pin Weldment	2
3.4	K1478	Hair Pin Cotter / Double Loop	2
4	B0943	Clamp Bracket / Weight Kit	1
5	Y0025	28 lb. Suitcase Weight	2

Figure 2-17b



2-18 Safety Interlock Wiring Harness Installation



P#(P0073)

P#(P0270)

2-18 Safety Interlock Harness Installation (Continued)

Collection System May Require Dealer Installation!

Before installing, please verify the presence of an auxiliary 5-way female connector in the mower's electrical harness. The connector is located underneath the operator's seat, near the (+) side of the battery.



WARNING

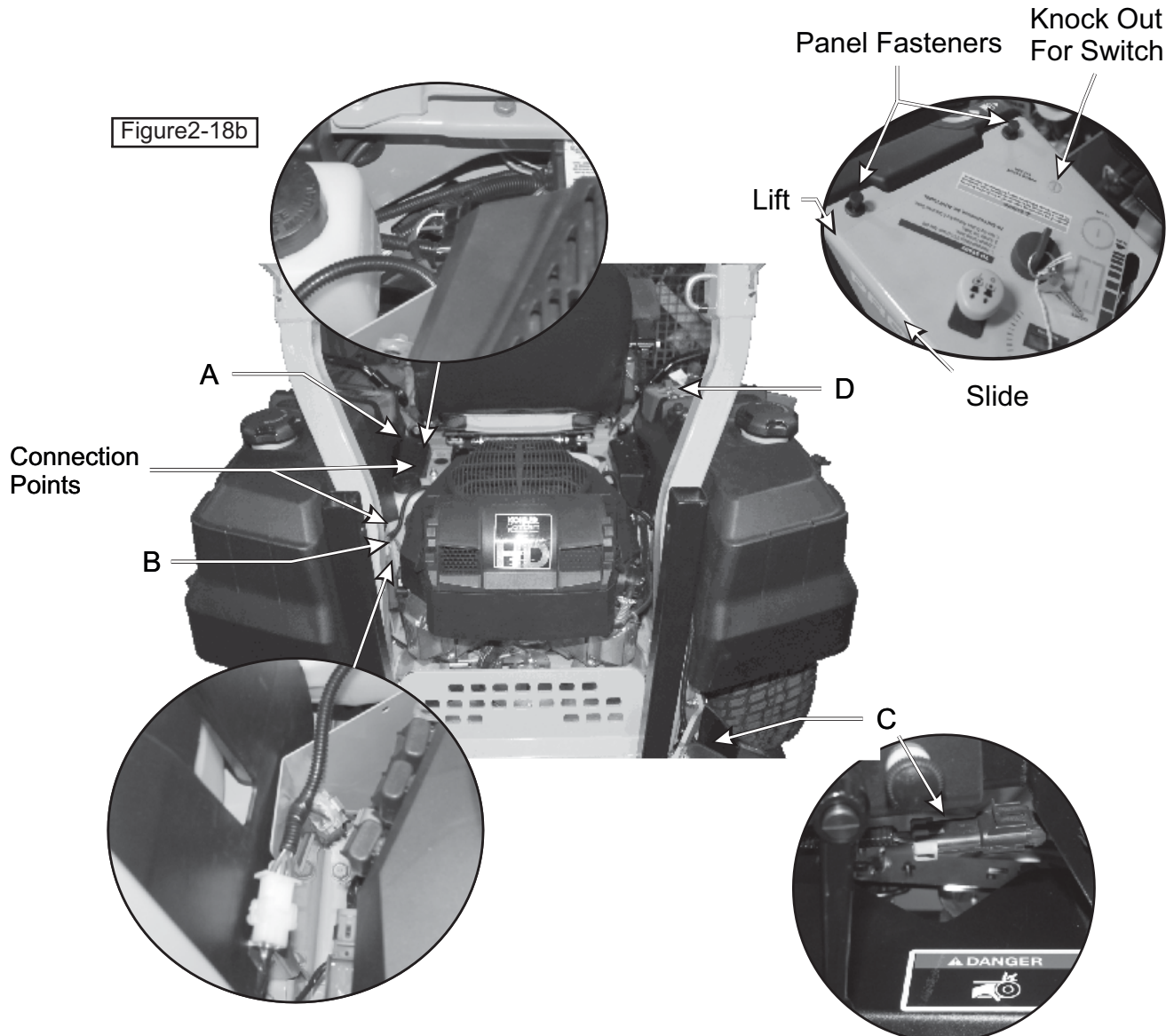
**To Prevent Serious Injury-
Proper Installation Of Safety Interlock Harness
Is Mandatory. Please Check That All Interlock
Points Work Correctly Once Installed.**

Connect (A) the Delphi 5-way Male connector, on the harness, to the connection point under the seat near the (+) side of the battery. Next, on the left side of the engine locate and separate the engine harness from the main harness and connect the Safety Interlock Harness (B) to each side of the motor harness and the mowers main harness. Refer to Figure 2-18a & b.

Route the PTO connector (C) around front side of engine, between the ROPS and gas tank and through the opening in the rear bumper connecting to the quick connect plug located on the PTO Drive.

Before routing the switch (D), remove safety cover from the top of the switch, locate and remove knock out on control panel. The control panel is easily removed by pulling the inner pin up on the fasteners. Lift the back section and pull towards the rear of the mower. Route harness (D) through the frame and up to the underside of the control panel. Insert switch into the knock-out hole, reattach safety cover and orientate the switch with the groove side forward.

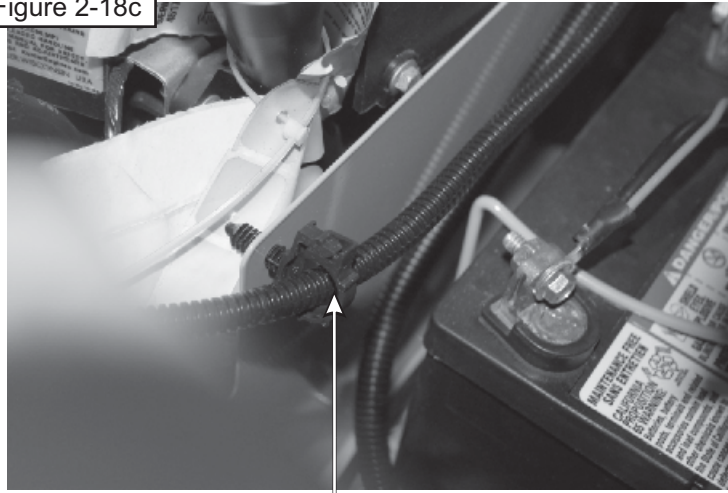
Note: Switch must be oriented correctly, to the harness connector, or mower will not start with switch in the off position.



2-18 Safety Interlock Harness Installation (Continued)

Once the safety interlock wiring harness is installed use the connectors provided to secure in place. Insert the rosebud clips in the 1/4" holes on the engine shield as shown. Zip straps are also included to aid in securing the harness. Refer to Figure 2-18c & d

Figure 2-18c



1/2" Rosebud Conduit Clip
P#(P0273)

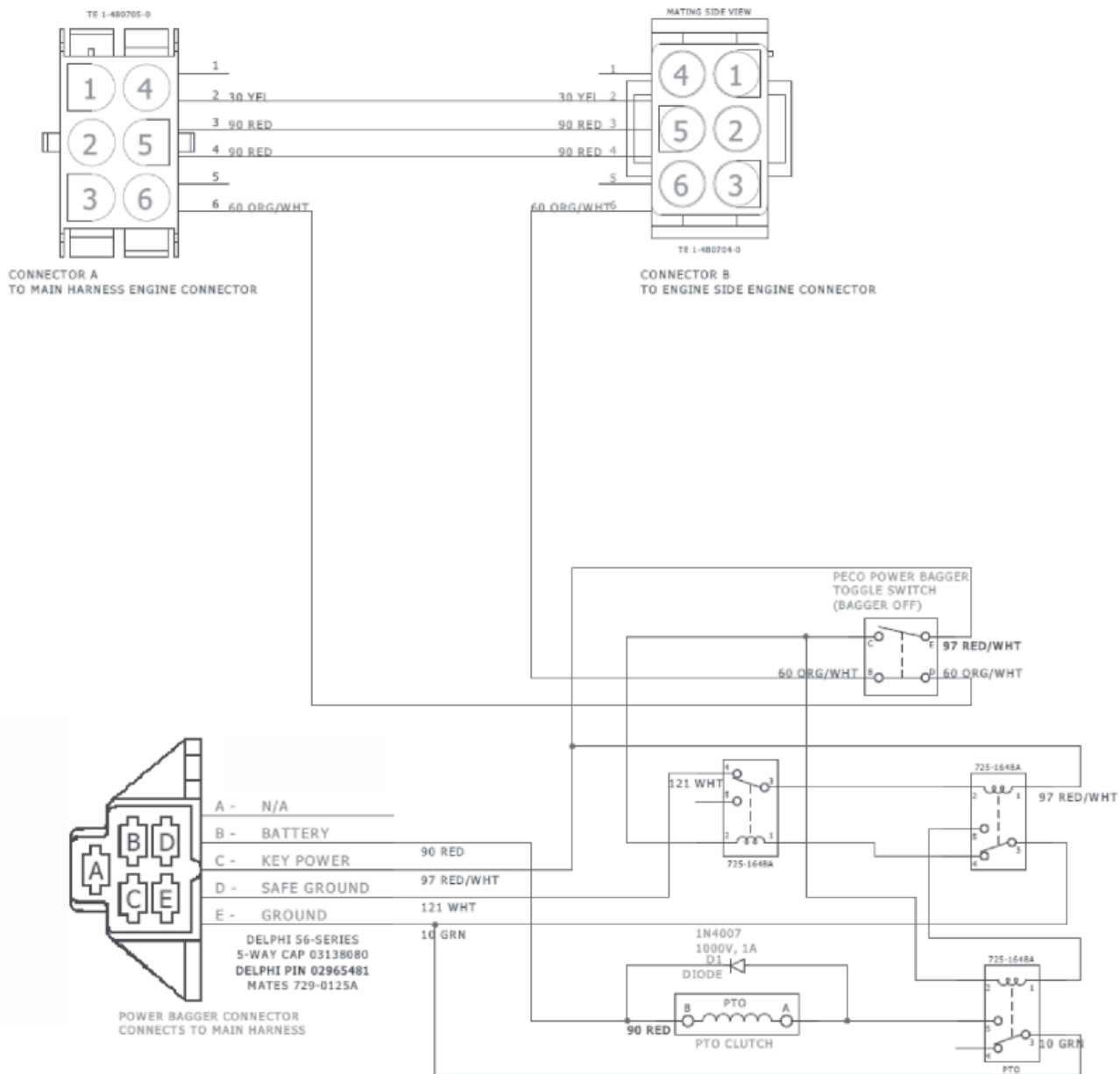
Figure 2-18d



Battery

1" Rosebud Conduit Clip
P#(0272)

2-18 Safety Interlock Harness Installation (Continued) Wiring Schematic



2-19 Impeller Blade Removal/Replacement

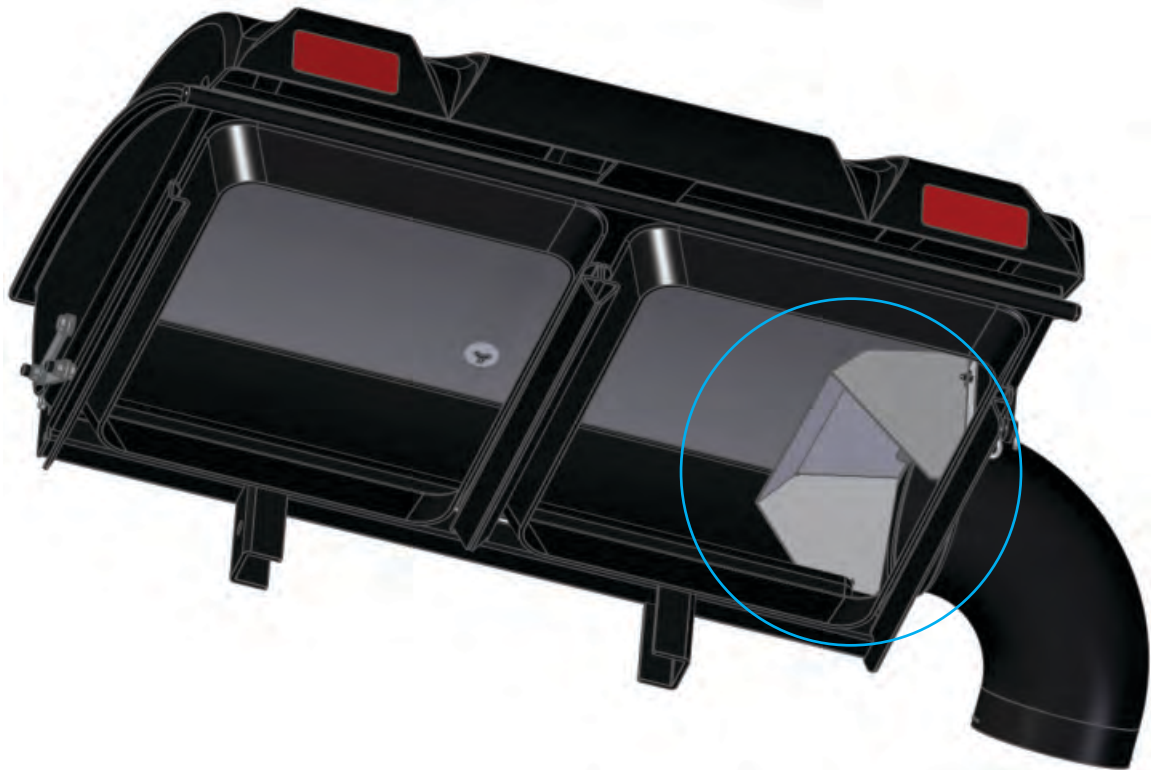
To Remove: First remove the 5/16"-24 x 1" HHCS P#(K0428) (#1), taper lock bushing washer P#(K0284) (#3), (2) 5/16 Flat Wahers P#(K0042) and spacer bushing P#(S0159) (#4) from the taper-lock bushing P#(S0157) (#5). See Figure 2-19. Next remove the (2) 1/4"-20 x 1" HHCS (#2) and place them into the threaded holes of the taper-lock bushing (#5). Gradually thread each bolt evenly into the taper-lock bushing, forcing the blade to break-away from the taper-lock bushing. If the impeller will not move, carefully hit the base of the impeller, between each vein, with a hammer, then try again.

To Replace: Place impeller blade over the engine shaft. Slide the taper-lock bushing (#5) on to the engine shaft and into the impeller blade, aligning the **non-threaded** holes of the taper-lock bushing to the threaded holes of the impeller blade. Fasten by using (2) 1/4"-20 x 1" HHCS (#2), (1) spacer bushing (#4) (1) taper lock bushing washer (#3), and (1) 5/16"-24 x 1" HHCS (#1). Torque to the proper specifications in the torque chart on the back of this manual. Next, rotate the impeller blade to ensure that the blade is clear of contact on all sides of the blower housing.

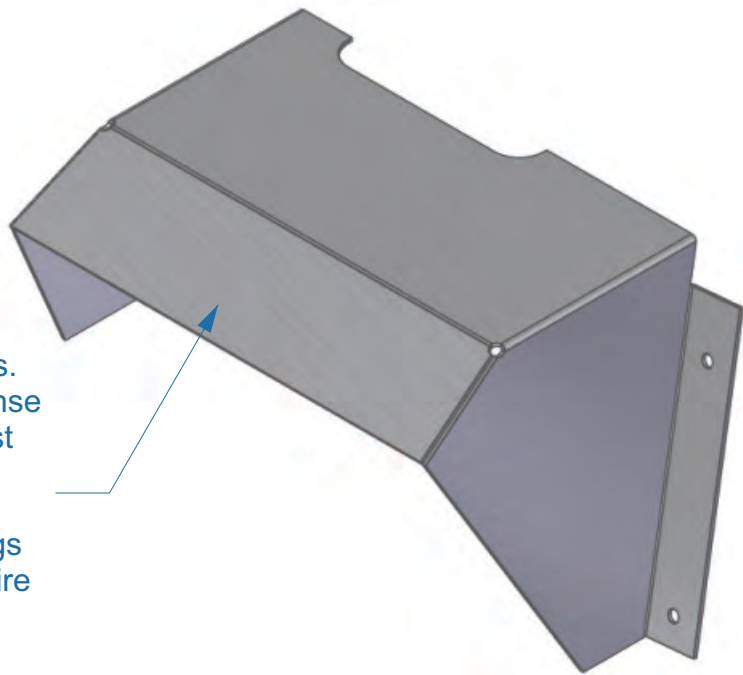


Figure 2-19

2-20 Even Bag Fill Adjustment

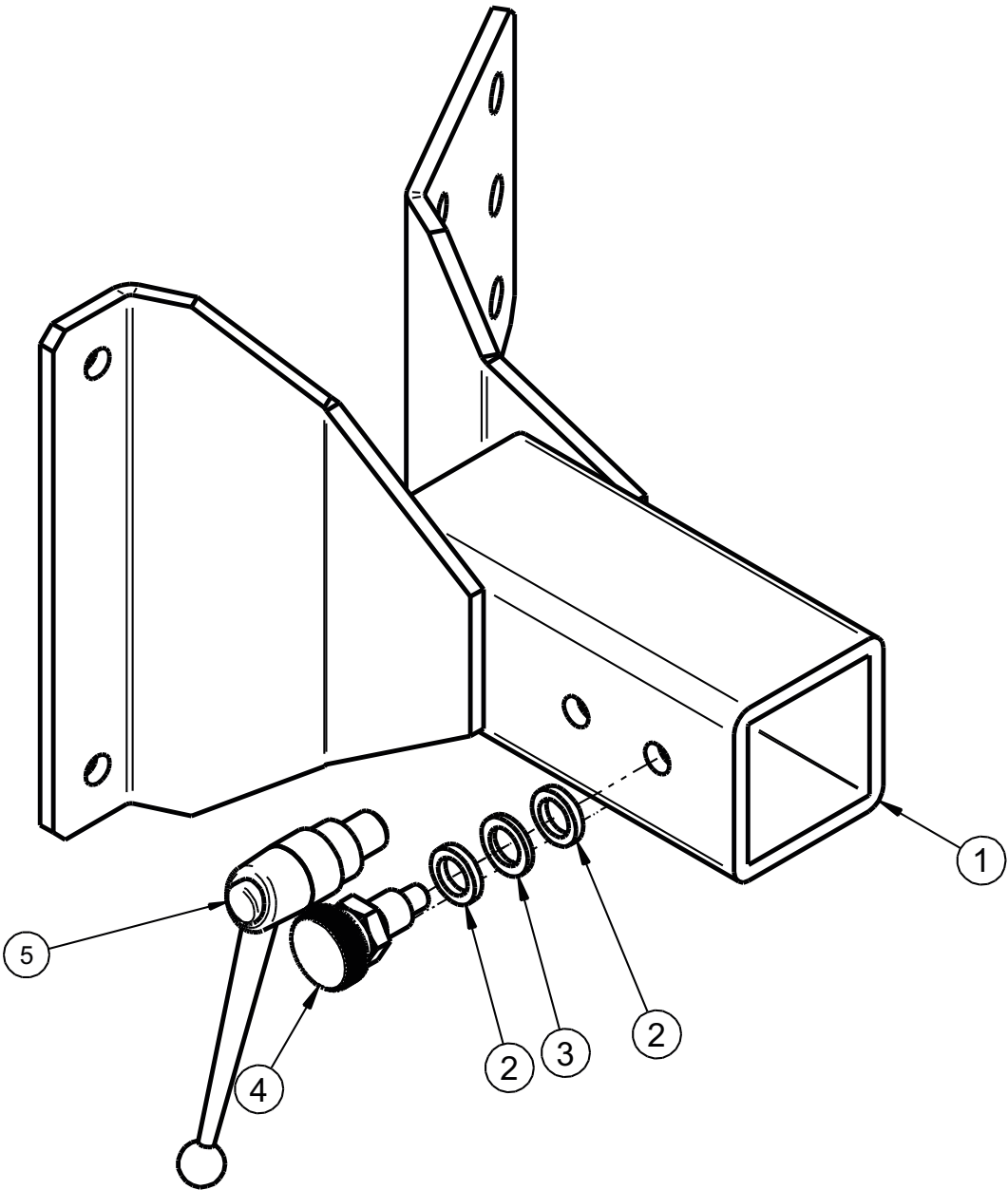


Flap Can Be Adjusted Up/Down Depending On Mowing Conditions. Adjust Flap Up To Allow More Dense Material To Reach Left Bag. Adjust Flap Down To Allow Less Dense Material To Reach The Right Bag. Once Adjusted Properly, Both Bags Should Fill Evenly, But May Require Further Adjusting When Mowing Conditions Change.



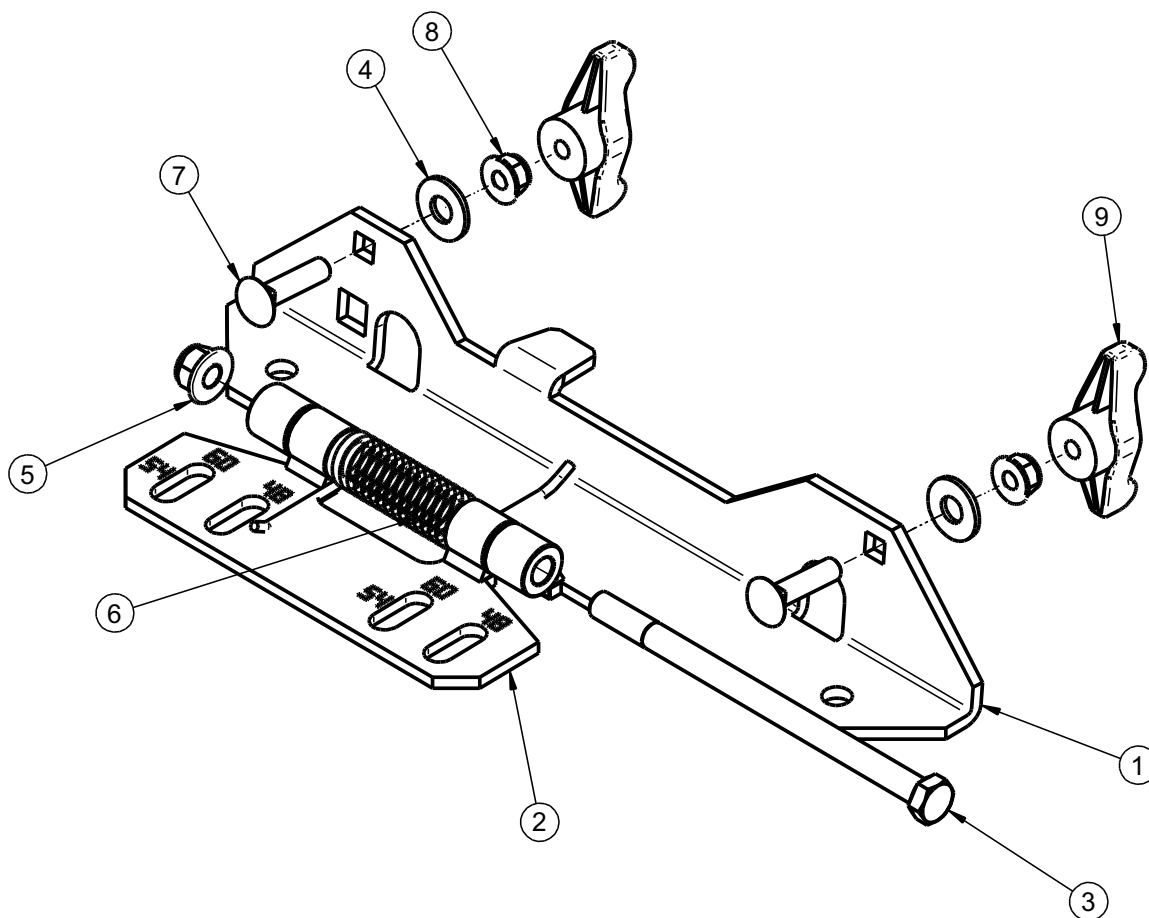
A2063_01 Mount Arm Assembly

Item #	Part #	Desc.	Qty.
1	A2033_01	Mount Arm Sub-Assy	1
2	J0013	Nylon Flat Washer 1/2" x .750" OD Grade 6/6	2
3	K0027	Flat Washer 1/2" / .787 OD x .512 ID x .090 T	1
4	J0020	Knob Plunger Pin 1/2"-13	1
5	J0009	Adjustable Handle 1/2"-13 x .59 Male	1

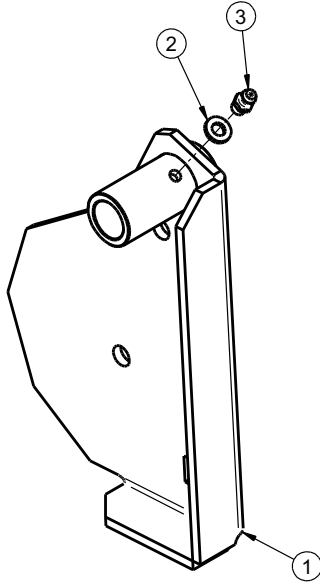


A2045 Boot Mounting Assembly

Item #	Part #	Desc.	Qty.
1	A2044	Deck Plate Assy	1
2	A2043	Boot Plate Assy	1
3	K1429	3/8"-16 x 6" HHCS GR5	1
4	K0042	Flat Washer 5/16" / .875 OD x .380 ID x .075 T	2
5	K2038	Ny-Flange Lock Nut 3/8"-16	1
6	J0017_1	Torsion Spring	1
7	K1146	5/16"-18 x 1-1/4" Carriage Bolt	2
8	K2516	Ny-Flange Lock Nut 5/16"-18	2
9	J0018	Wing Knob / 5/16-18 Thru Nut	2



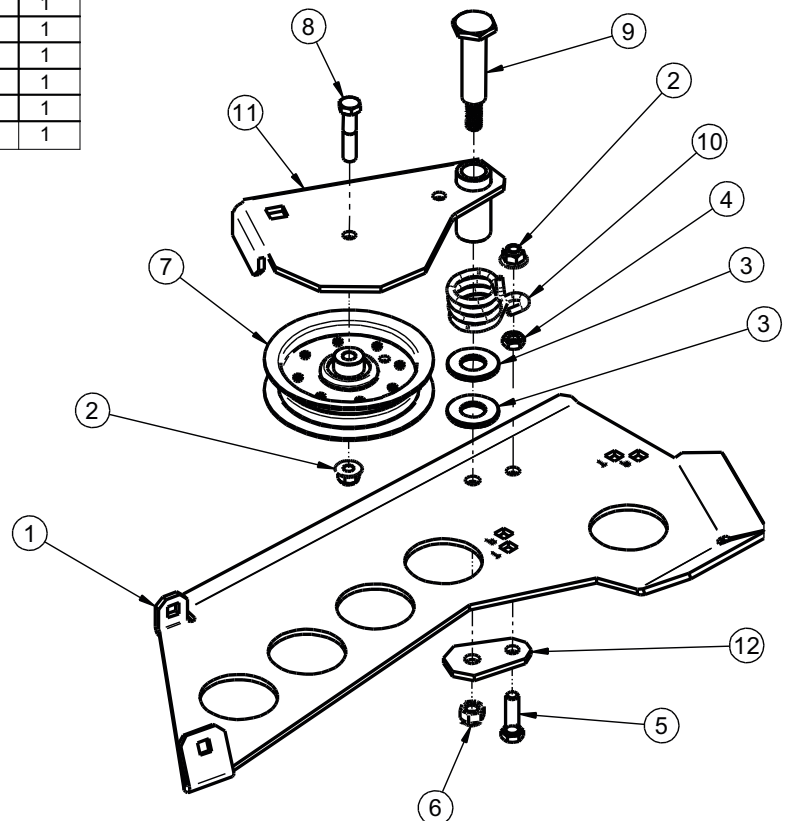
A2092 Idler Arm Assembly



Item #	Part #	Desc.	Qty.
1	A2070_01	Idler Arm Weldment	1
2	K1467	Flat Washer M6 x 12mm OD	1
3	J0801	1/4"-28 Zirc Fitting	1

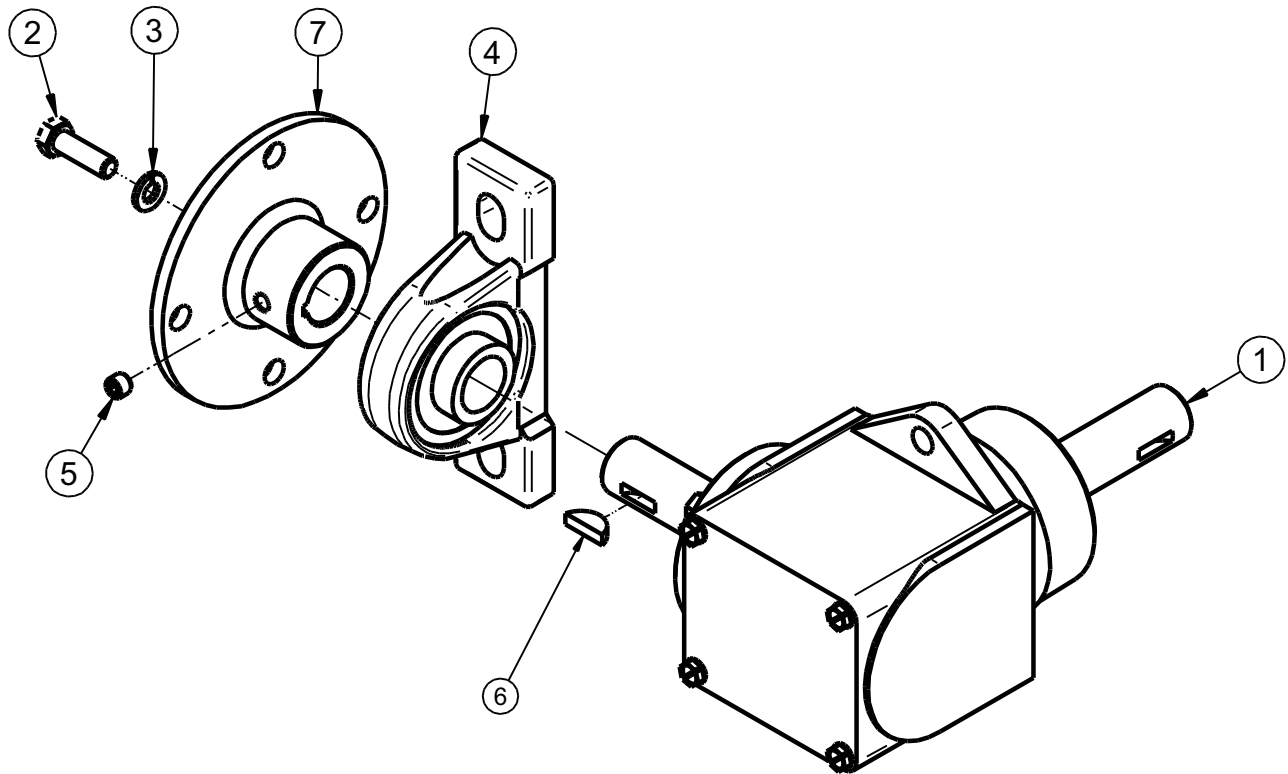
A2067_02 Idler Mount Assembly

Item #	Part #	Desc.	Qty.
1	B0958_02	Idler Mnt Pl	1
2	K2038	Ny-Flange Lock Nut 3/8"-16	2
3	K1463	Flat Washer .720 ID x 1.500 OD x .250 T	2
4	K1219	Jam Nut 3/8"-16	1
5	K1192	HHCS 3/8"-16 x 1-1/4" GR5	1
6	K0329	Nylock Nut 7/16"-14 GR8	1
7	M0003	Idler Pulley	1
8	K1462	HHCS 3/8"-16 x 1-3/4" GR8	1
9	K1464	Shoulder Bolt 7/16"-14 / Idler	1
10	J0024	Torsion Spring	1
11	A2092	Idler Arm Assy	1
12	B0974	Idler Base Plate	1



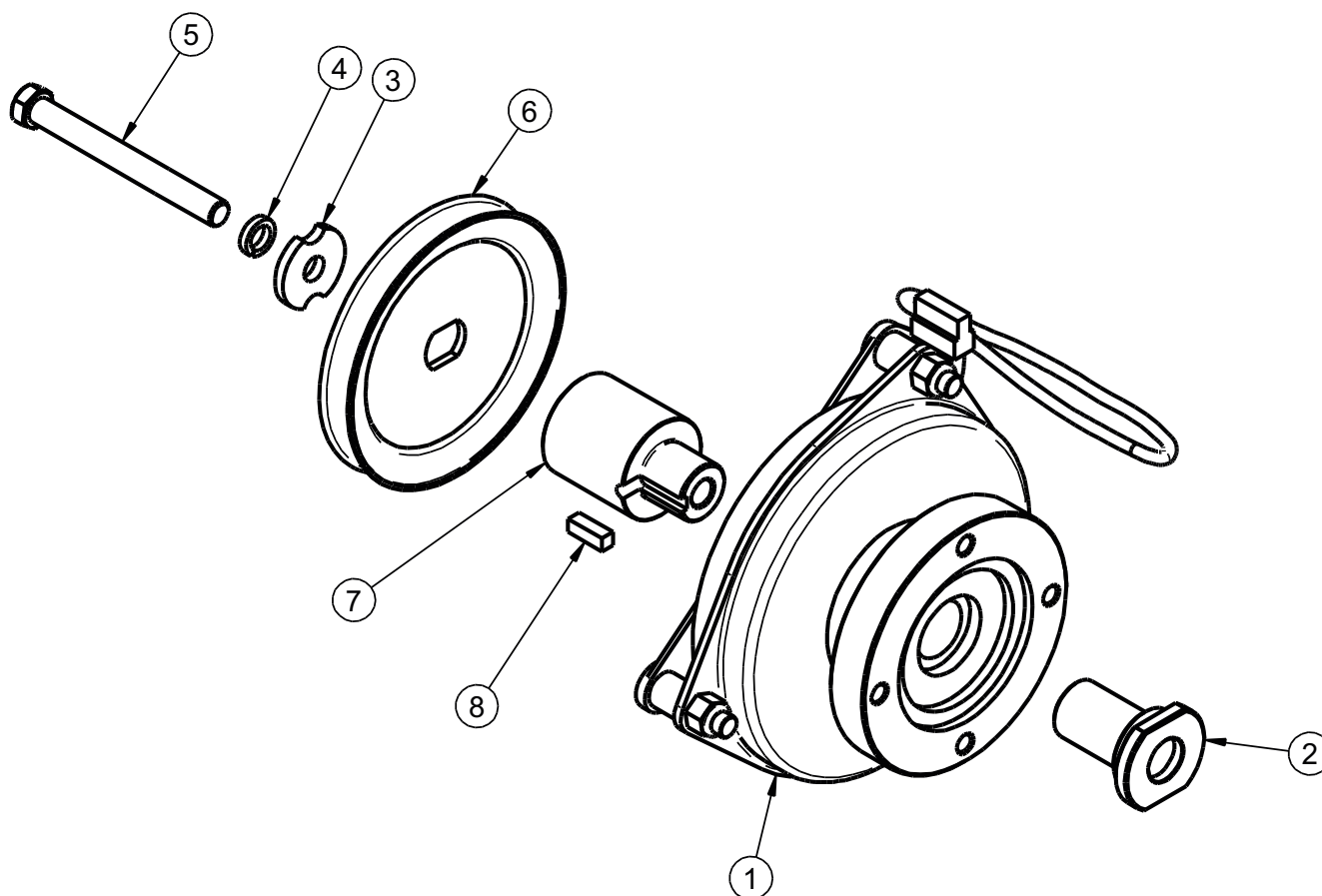
A2058 Gearbox Sub-Assembly

Item #	Part #	Desc.	Qty.
1	M0002	Gearbox	1
2	K0428	HHCS 5/16"-24 x 1" GR8	1
3	K0043	Lock Washer 5/16"	1
4	N0002	Pillow Block Bearing 7/8"	1
5	K0035	Set Screw 5/16"-18 x 1/4" Cup Point	1
6	J0272	Woodruff Key #9	1
7	A2048	Clutch Flange Assy	1



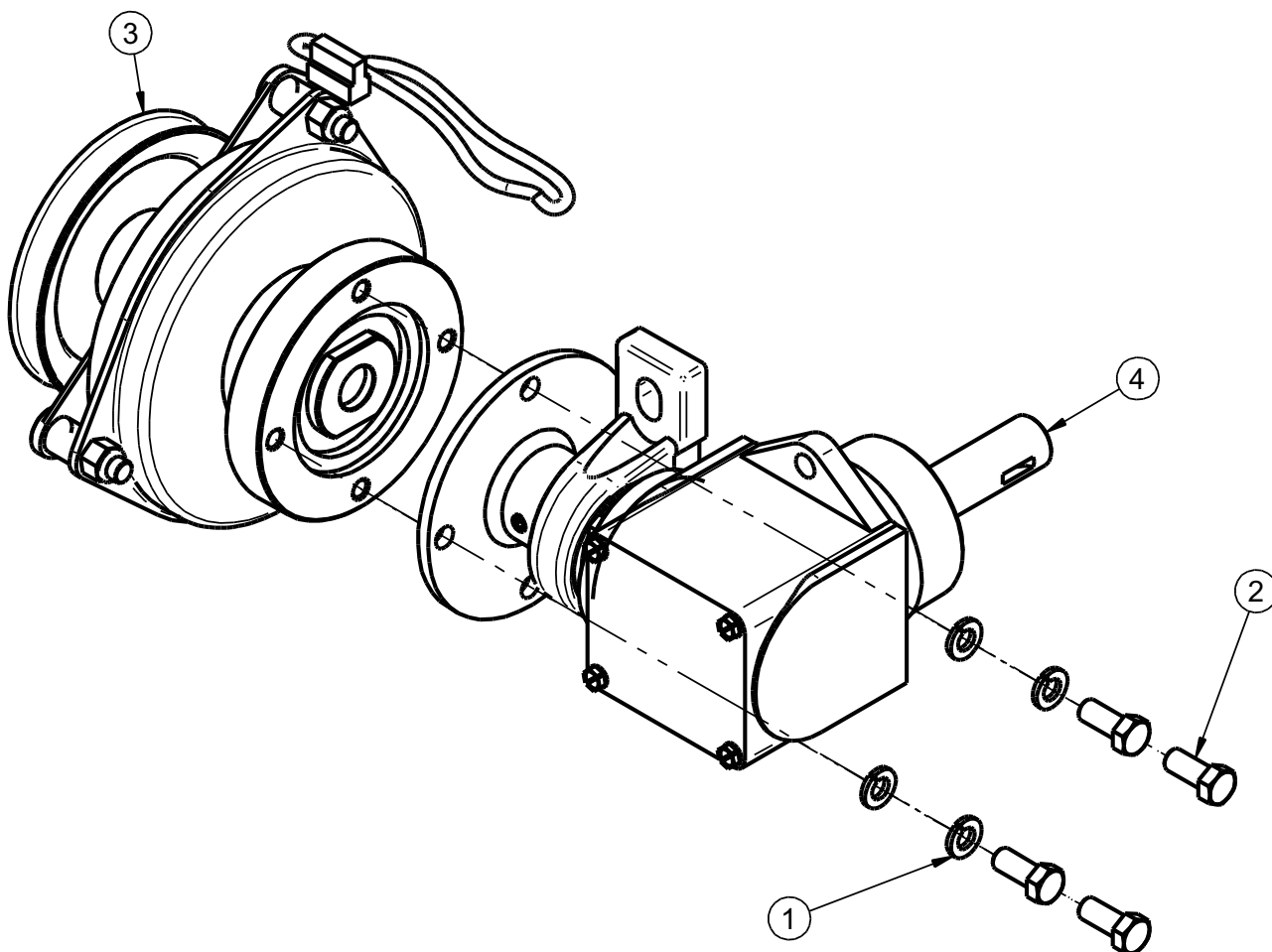
A2059_01 Clutch Sub-Assembly

Item #	Part #	Desc.	Qty.
1	M0001	Electric Clutch (Ogura 110 Ft-Lb Clutch/Brake)	1
2	S0007	Clutch Shaft	1
3	K0278	Double Indented Washer 7/16" / 1.375 OD x .440 ID x .179 T	1
4	K0140	Lock Washer 7/16" / High-Collar Helical Spring	1
5	K0359	HHCS / 7/16"-20 x 4.00" w/ Patch	1
6	M0309	A-Section Pulley / 4.75 OD	1
7	S0221	Eng. Pulley Bushing #27	1
8	K0076	Key 1/4" x 3/4" Long	1



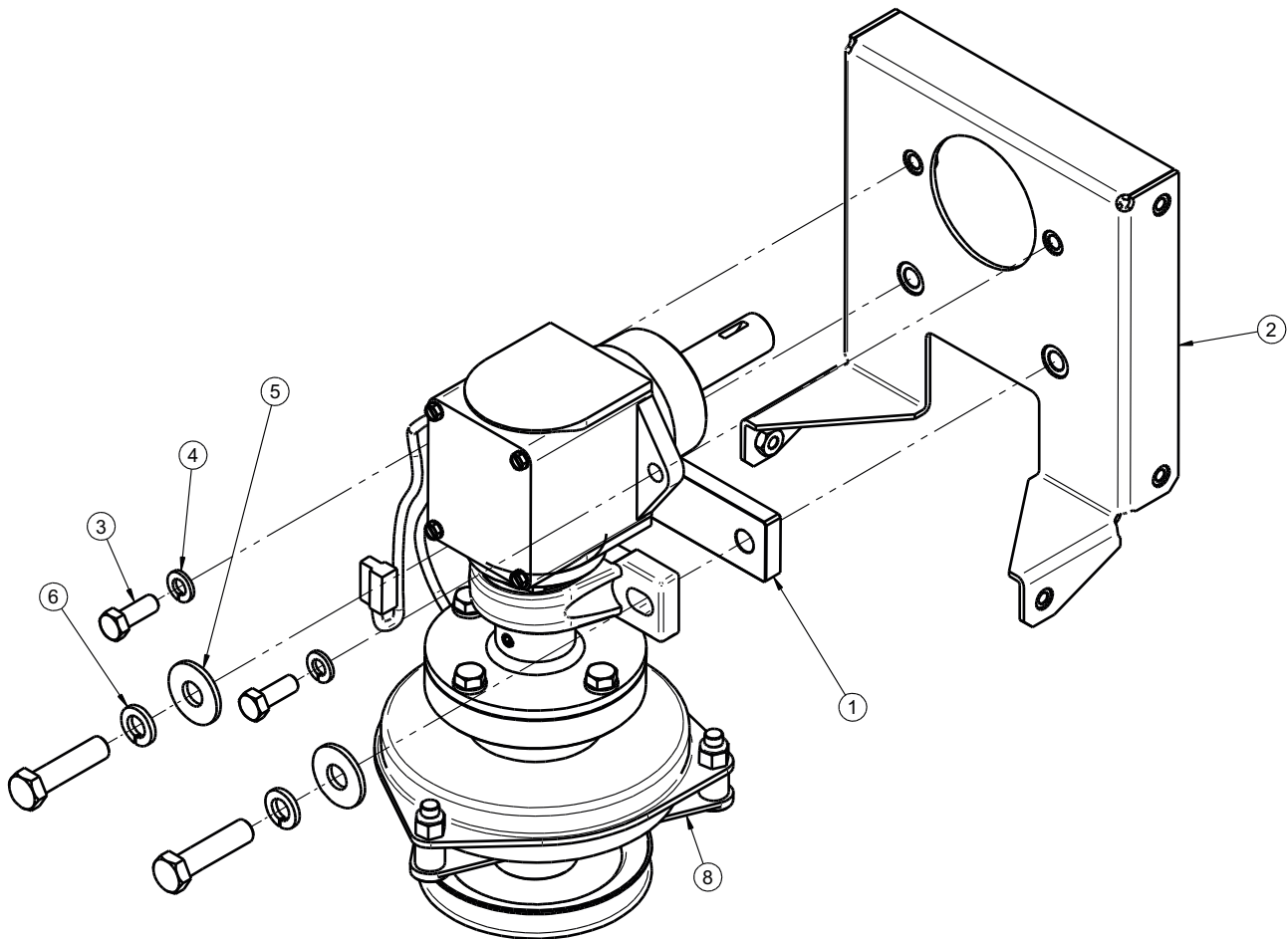
A2057_01 Drive Assembly Exploded Parts View

Item #	Part #	Desc.	Qty.
1	K0048	Lock Washer 3/8"	4
2	K0343	HHCS 3/8"-16 x 7/8" GR8	4
3	A2059_01	Clutch Sub-Assy (See Page 26)	1
4	A2058	Gearbox Sub-Assy (See Page 25)	1



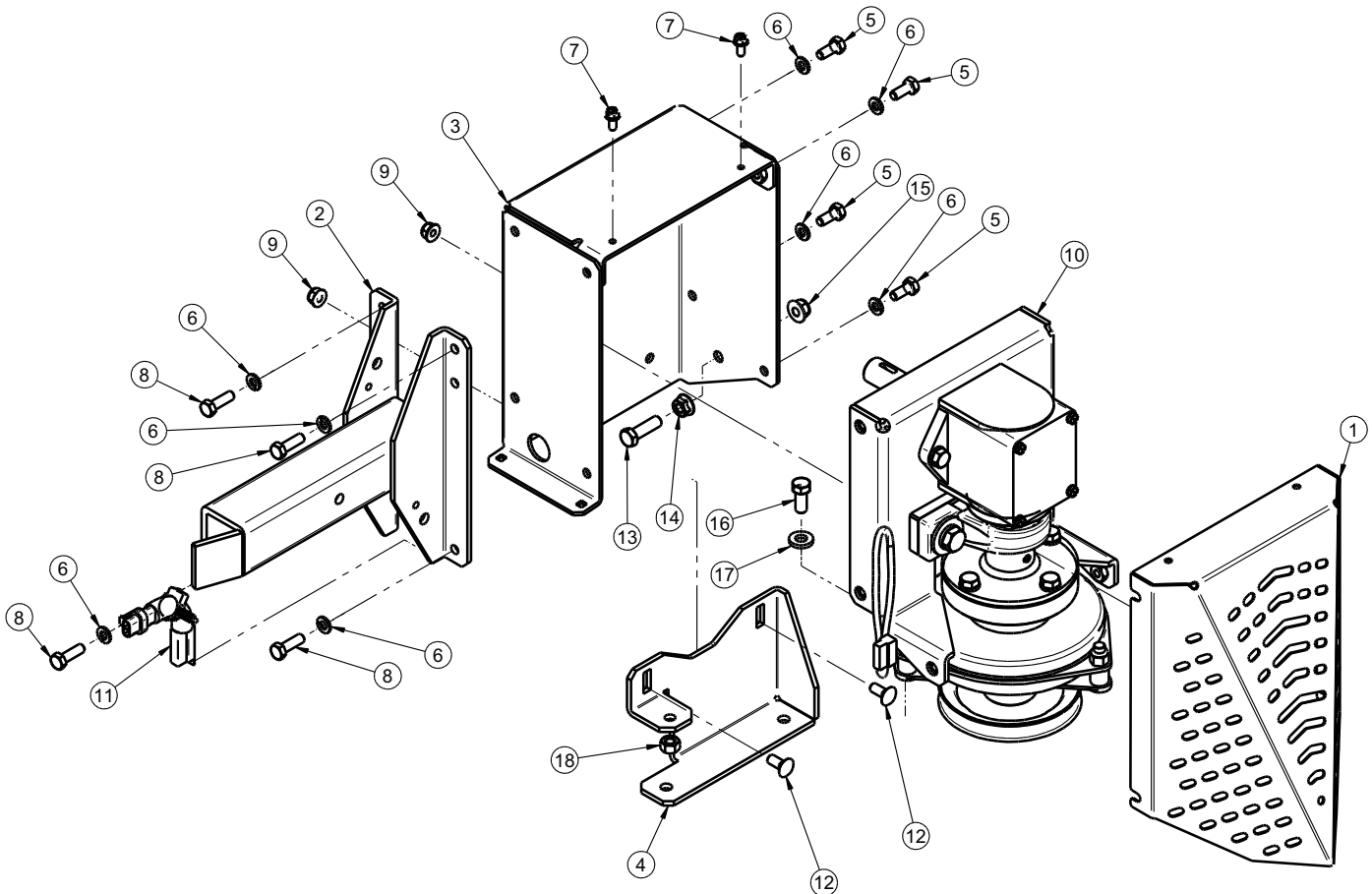
A2060_01 Mounted Drive Assembly

Item #	Part #	Desc.	Qty.
1	B0940	Spacer Plate	1
2	A2034	Drive Mnt Assy	1
3	K1191	HHCS 3/8"-16 x 1" GR5	2
4	K0048	Lock Washer 3/8"	2
5	K0055	Flat Washer 1/2" / 1.383 OD x .560 ID x .120 T	2
6	K0056	Lock Washer 1/2"	2
7	K1234	HHCS 1/2"-13 x 2"	2
8	A2057_01	Drive Assy (See page 27)	1



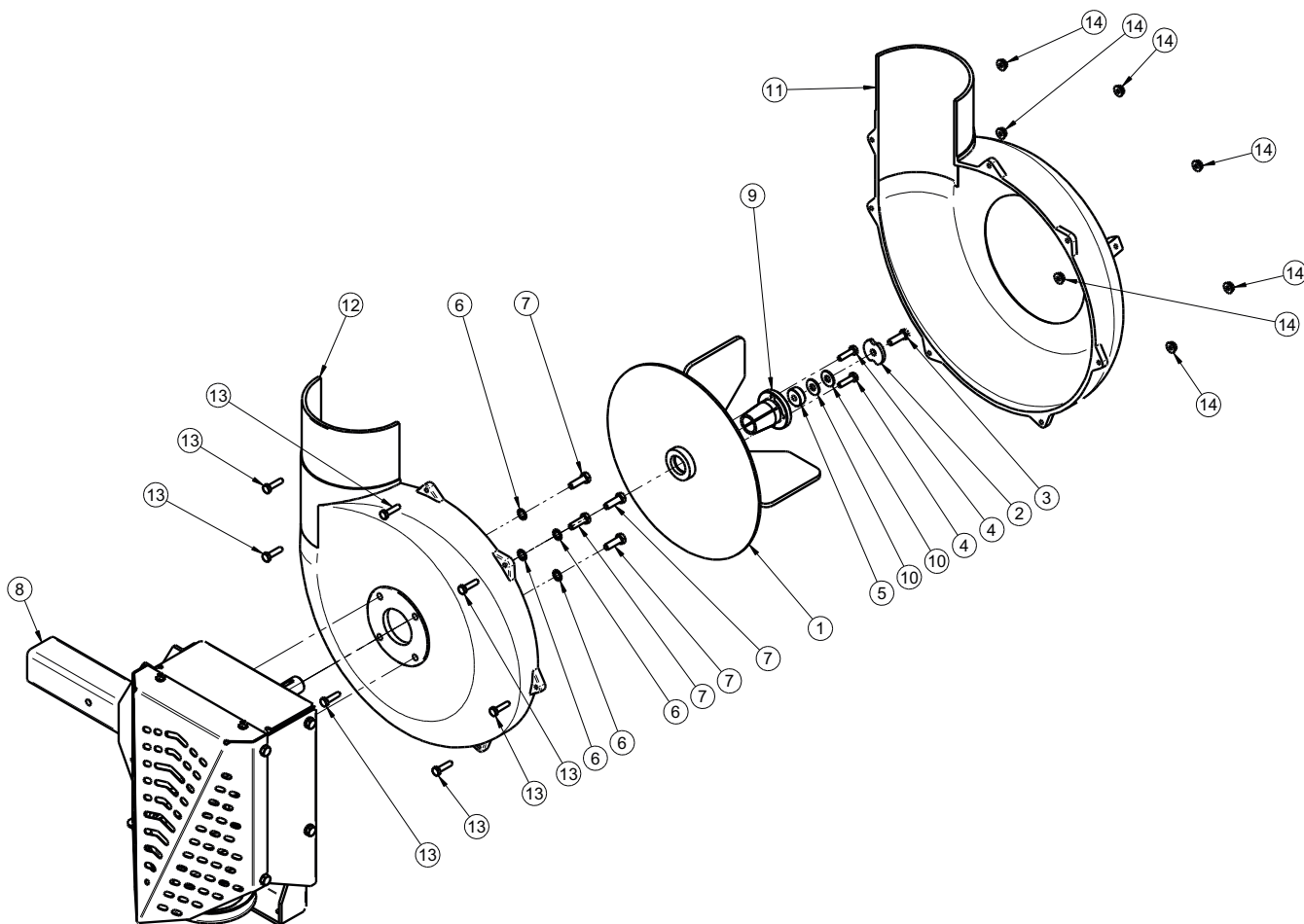
A2039_01 Base Drive Assembly

Item #	Part #	Desc.	Qty.
1	B0938	Drive Guard	1
2	A2032	Drive Arm Assy	1
3	A2035_01	Housing Mnt Assy	1
4	B0942_01	Anti-Rotation Brkt	1
5	K1153	HHCS 5/16"-18 x 3/4"	4
6	K0043	Lock Washer 5/16"	8
7	K0353	HWHTCS 1/4"-20 x 1/2"	2
8	K1154	HHCS 5/16"-18 x 1"	4
9	K2516	Ny-Flange Lock Nut 5/16"-18	2
10	A2060_01	Mounted Drive Assy	1
11	P0271	Quick Connect Wire Harness	1
12	K1142	5/16"-18 x 3/4" Carraige Bolt	2
13	K0509	3/8"-16 x 1-1/4" GR8 HHCS	1
14	K1215	Flange Nut 3/8"-16	1
15	K2038	Ny-Flange Lock Nut 3/8"-16	1
16	K0343	HHCS 3/8"-16 x 1-1/8" GR8	1
17	K1477	Flat Washer / 3/8" / .406 ID x .812 OD x .125 Thk	1
18	K1476	Reverse Lock Nut / 3/8"-16 Grade C	1

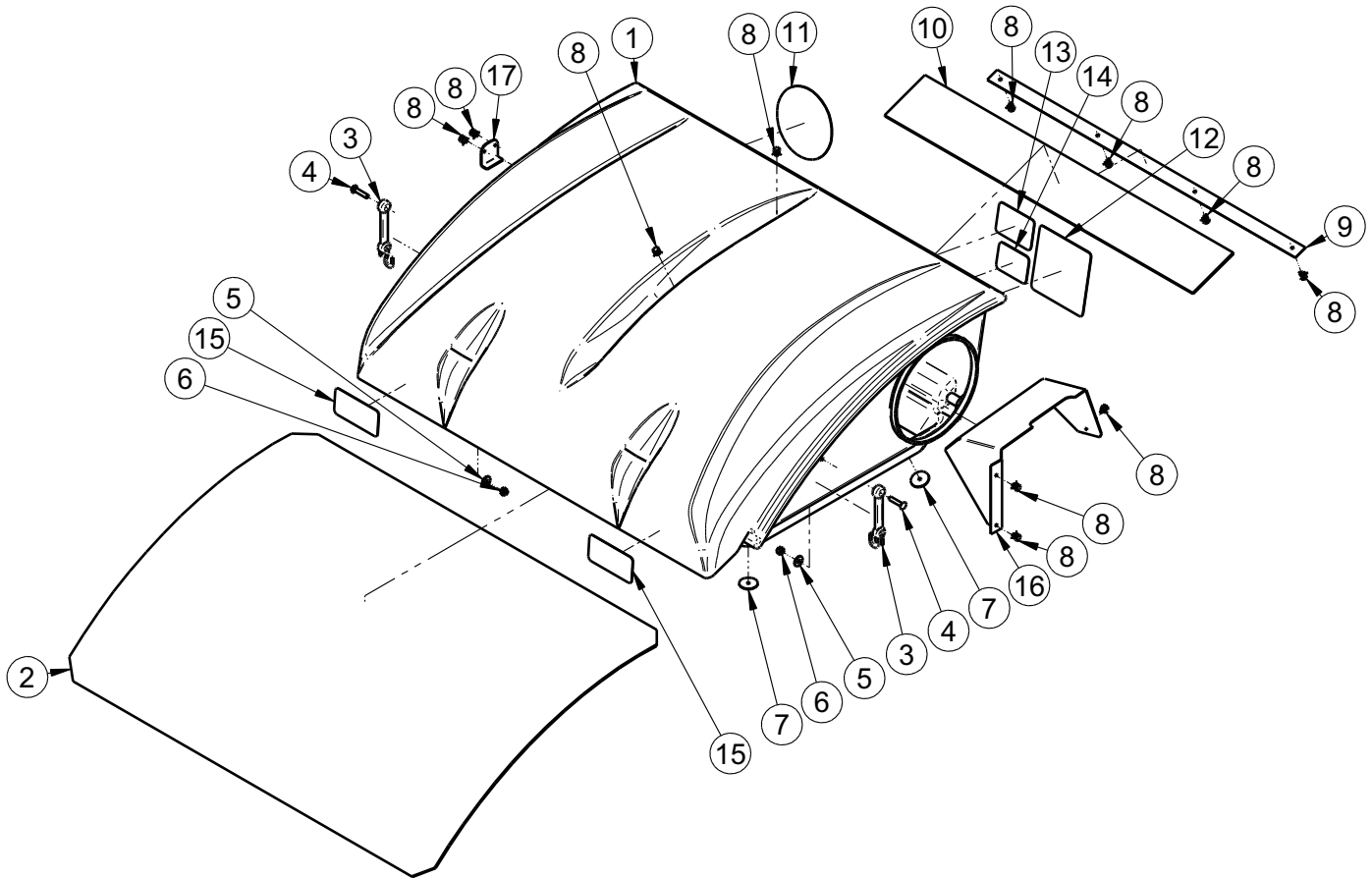


A2061 01 Drive Assembly / 4 Blade Impeller

Item #	Part #	Desc.	Qty.
1	A0645	4-Blade Impeller Assy	1
2	K0284	Double Indented Washer 3/8" / 1.375 OD x .380 ID x .179 T	1
3	K1465	HHCS 5/16"-24 x 1-1/2" GR8	1
4	K1225	HHCS 1/4"-20 X 1" GR8	2
5	S0159	Spacer Bushing .938 OD x .325 ID x .375 T	1
6	K0044	I/T Tooth Lock Washer 5/16"	4
7	K1154	HHCS 5/16"-18 x 1"	4
8	A2039_01	Drive Assy / Base	1
9	S0157	Taperlock Bushing 7/8"	1
10	K0042	Flat Washer 5/16" / .875 OD x .380 ID x .075 T	2
11	E4052F	Blower Hsg Front	1
12	E4052B	Blower Hsg Back	1
13	K1125	HHCS 1/4"-20 X 1" GR2	7
14	K1126	Flange Nut 1/4"-20	7



A2110 Top Assembly Exploded Parts View



Item #	Part #	Desc.	Qty.
1	V2000	Pro 2 Bagger Top / Gen. 2	1
2	V2001	Screen	1
3	J4009	Short Rubber Strap w/ S-Hook	2
4	K1030	1/4"-20 x 1-1/4" Carriage Bolt	2
5	K0037	Flat Washer / 1/4" (.75 OD x .312 ID x .060 T)	2
6	K1128	1/4"-20 Nyloc Nut	2
7	K0062	3/16" x 1-1/2" Fender Washer, Z	2
8	K0114	Black Plastic Rivet	11
9	C0067	Dust Guard Mnt. Brkt.	1
10	V1117	Dust Guard	1
11	R0022	Decal / Built In The USA / Lg	1
12	R1069	Decal / Warning - Turn Off Blower	1
13	R1054	Decal / Important Check Hoses	1
14	R1051	Decal / Warning - Use Hearing Protection	1
15	R1057	Decal / 2" x 4" Red Reflector	2
16	C0026	Grass Deflector	1
17	B0676	Hinge Stop Pl.	1



Unit Model #: 59A30046150 (21120902)

Mower & Type: Cub Cadet Pro Z 100 Series

Mower Models: Pro Z 148S EFI, Pro Z 154S EFI, Pro Z 160S EFI, Pro Z 148L EFI, Pro Z 154L EFI, Pro Z 160L EFI

Vac Serial Range: 2E226XP0001 & Up

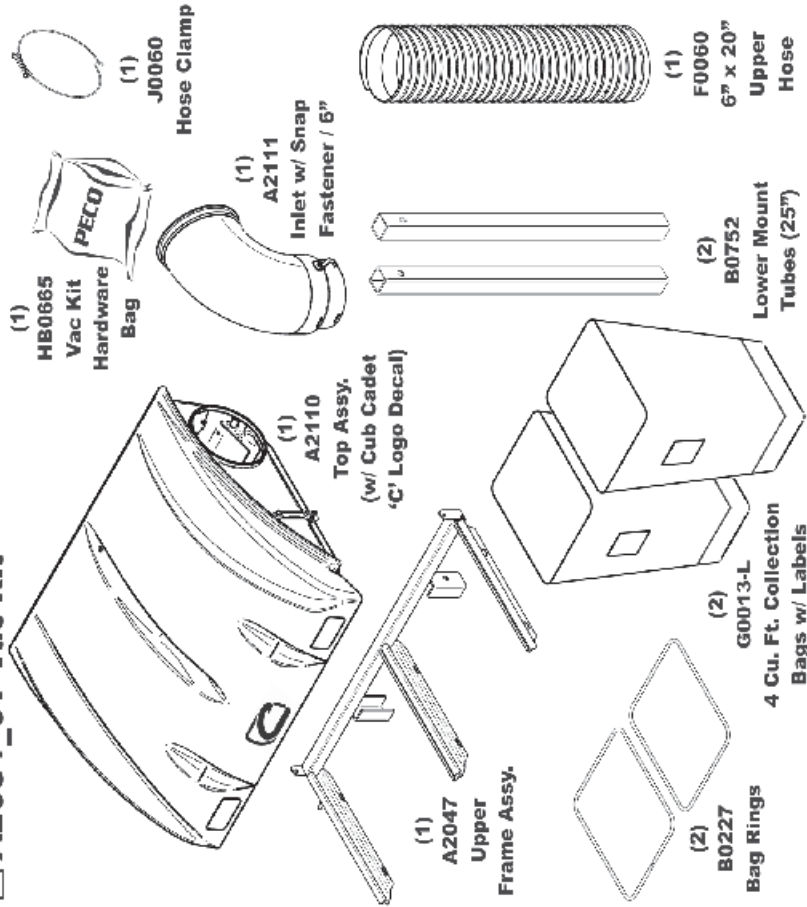
Owner's Manual: Q0506

Vac/Drive Type: P2B+ (9 Cu. Ft.) PTO-X Driven

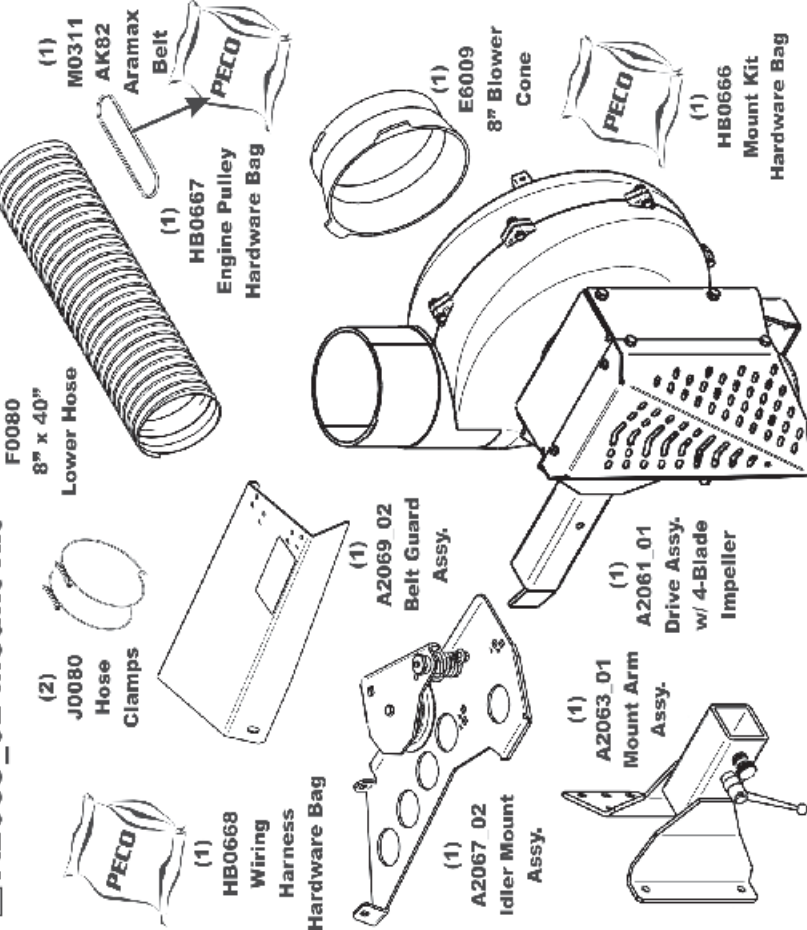
Revision #: 3 - Upd Weight Kit - JPS 4/17/2017

Fits Year[s]: 2016 & Newer

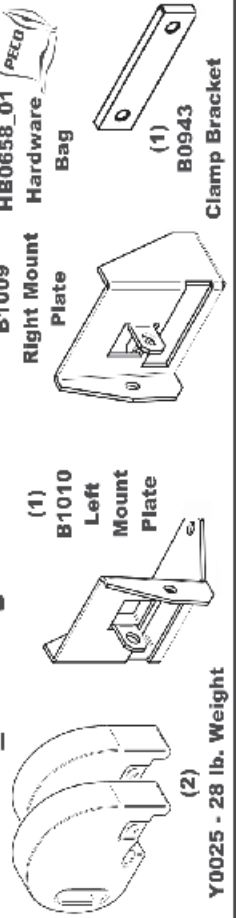
A2064_01 Vac Kit



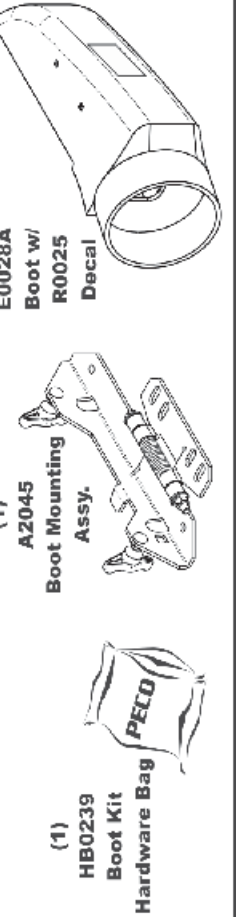
A2065_02 Mount Kit



A2042_01 Weight Kit



A2066 Boot Kit



SAFETY DECALS

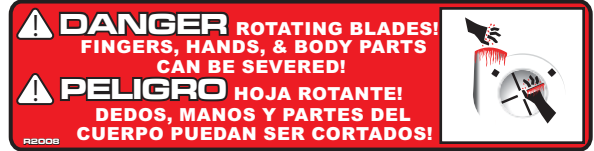
To promote safe operation, New PECO, Inc. supplies safety decals on all products manufactured. Damage can occur to safety decals either through shipment, use or reconditioning. Contact your local Service Center for replacement decals.



Part# R0023
Cub Cadet
Logo



Part #: R2007
Never Use Hands Label



Part #: R2008
Rotating Blades Label



Part #: R1100
Engage-Disengage Label



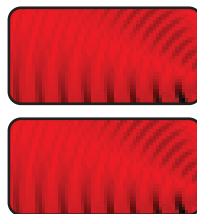
Part #: R4037
Warning: Hot Surface Label



Part #: R1052
Small Warning: Turn Off Blower Label



Part #: R1054
Important Label



Part #: R1057 - (2)



Part #: R1069
Warning: Turn Off Blower Label



Part # R0024
Danger Keep Hands
Clear



Part #: R1051
Warning: Hearing Protection Label



Part # R0025
Danger Rotating
Blades

SECTION III OPERATING INSTRUCTIONS

3-1 General Safety

Only qualified people familiar with this operator's manual and the mower's operator's manual should operate this machine.

3-2 Operation And Tips On Mowing

- A. Perform BEFORE EACH USE the maintenance list in paragraph 4-1.
- B. Start mower.
- C. With the mower at high idle speed, engage the mower deck.
- D. While seated in the operator's seat, pull the engagement handle of the PTO assembly towards the operator's seat until the handle slides into position in the retaining slot. With the PTO assembly engaged, you can proceed to operate the control levers of the mower.

NOTE: If the collection system does not appear to be collecting the grass clippings, disengage the deck and PTO assembly (Section 3-3), then, engage the parking brake and turn the mower off. Check upper and lower hoses for any clogs.

To obtain the maximum effectiveness from your collection system, the tips listed below should be followed:

- * Watch your speed- Normal conditions will allow a speed of up to approximately 4 mph, but thick, heavy damp conditions will require reduced ground speed.
- * Mow with sharp blades- A sharp blade cuts cleaner.
- * Wet grass and leaves will decrease effectiveness and will increase horsepower requirements.
- * Mow at higher cutting heights- Remove and mulch no more than 2" of grass length with each mowing. (Experts recommend not cutting off more than 1/3 of the grass blade length at any given time.)
- * Mow twice, at different height settings, (high, then low), if grass is extra tall.
- * Remember that horsepower requirements will vary with the mowing conditions such as type and height of turf grass, moisture content, amount of leaves, whether the terrain is flat or hilly, etc.

3-3 Disengagement Of The PTO Assembly

A. To disengage the PTO assembly, move switch to the off position.

WARNING: The PTO assembly blades will continue to spin. DO NOT TOUCH the PTO assembly, pulleys, or the belt until the tractor is turned off. DO NOT adjust the belt tension until the mower is turned off. Refer to section 2-4 of the manual.

3-4 Unloading The Collection System

NOTE: To determine when the collection bags are full, follow the following steps:

- A. Stop the forward movement of the mower.
- B. Disengage the mower deck.
- C. Disengage the PTO assembly.
- D. Engage the parking brake.
- E. Once the parking brake has been engaged, then and only then, walk behind the mower and check the collection bags by first unhooking the rubber strap with S-hook that secures the plastic top, then lift the plastic hood. Load in bags should not exceed the height of the installed bag.
- F. To remove the bags from the frame, slide bags out and turn bags over to deposit clippings.
- G. Slide empty bags back onto the frame and secure plastic top with the rubber strap with S-hook.

NOTE: Do not allow collection bags to become over-filled as potential damage may occur to your equipment. Also, be sure to clean the hood screen as needed.

SECTION IV MAINTENANCE

4-1 Maintenance Checklist

Before each use:

1. Check blades and spindles to be sure that no foreign objects, such as wire or steel strapping bands, are wrapped around them.
2. Inspect blades for wear. Replace if necessary. If it is necessary to sharpen the blades, remove the blades from the spindles before sharpening. DO NOT sharpen blades while still attached to the mower.

3. Make sure all shields are in place and in good condition. Repair or replace any missing or damaged shields.
4. Perform lubrication per paragraph 4-2.
5. Listen for abnormal sounds, which might indicate loose parts, damaged bearings, or other damage. Correct any deficiency before continuing operation.
6. With the engine off check the belt tension and inspect the pulley belt for cracks or tears.
7. Check for wear or deterioration of the upper or lower hoses. If there are any portions of the hose that have been torn or worn through, replace immediately.

After Each Use:

1. Clean all debris from machine especially from the container, underneath the belt shields, and safety decals. Replace any missing or illegible decals.
2. Inspect the unit for worn or damaged components. Repair or replace before the next use. Any replacement component installed during repair shall include the component's current safety decal specified by the manufacturers to be affixed to the component.
3. Check belt for proper tension.

4-2 Lubrication

Gearbox:

1. Every 20 hours of use: Check oil levels in gearbox.
2. First 60 hours of use: Change oil.
3. Every 100 hours of use: Change oil.

NOTE: Oil in gearbox should cover the gears. If not, drain the gearbox and fill using an 80W-90 gear oil. The gearbox ships with 6.0 oz. of oil, but we recommend replacing with a measured 5.5 oz. to fill the gearbox. **DO NOT OVERFILL!**

Blower Assembly:

1. Every 100 hours grease idler arm grease fitting with white lithium grease.

**SECTION V
PARTS AND SERVICE**

5-1 Parts And Service Information

Collection system owners should record the name and telephone number of their Service Center. Your Service Center will be happy to supply replacement parts, accessories, and do any service or repairs to your collection system. If for any reason your Service Center is unable to service your collection system or supply replacement parts, contact New PECO, Inc. and include the following information on the chart below.

THE SERIAL NUMBER PLATE
IS LOCATED ON THE TOP
ASSEMBLY

WRITE THE MODEL AND
SERIAL NUMBER IN THE
BOX TO THE LEFT
FOR FUTURE REFERENCE.

MODEL: 59A30046150
SERIAL: 2 XP

R0007

Unit Model Number: _____

Unit Engine Size: _____

Unit Serial Number: _____

Date of purchase: ____/____/____

Dealer/Distributor Name: _____

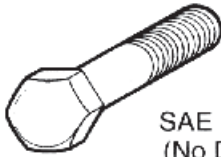
Address: _____ **State:** _____ **Zip:** _____

Phone Number: _____

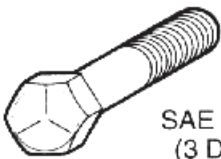
TORQUE SPECIFICATIONS

Proper torque for American fasteners used on PECO equipment.
Recommended Torque in Foot Pounds (Newton Meters).*

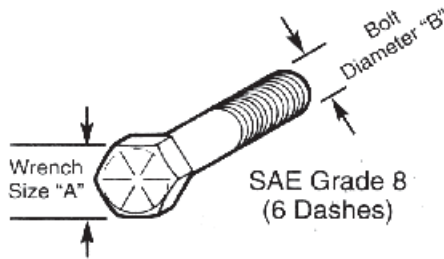
AMERICAN Bolt Head Markings



SAE Grade 2
(No Dashes)



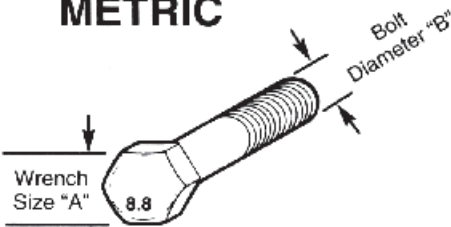
SAE Grade 5
(3 Dashes)



SAE Grade 8
(6 Dashes)

WRENCH SIZE (IN.) "A"	BOLT DIAMETER (IN.) "B" AND THREAD SIZE	SAE GRADE 2	SAE GRADE 5	SAE GRADE 8
7/16	1/4 - 20 UNC	6 (7)	8 (11)	12 (16)
7/16	1/4 - 28 UNF	6 (8)	10 (13)	14 (18)
1/2	5/16 - 18 UNC	11 (15)	17 (23)	25 (33)
1/2	5/16 - 24 UNF	13 (17)	19 (26)	27 (37)
9/16	3/8 - 16 UNC	20 (27)	31 (42)	44 (60)
9/16	3/8 - 24 UNF	23 (31)	35 (47)	49 (66)
5/8	7/16 - 14 UNC	32 (43)	49 (66)	70 (95)
5/8	7/16 - 20 UNF	36 (49)	55 (75)	78 (106)
3/4	1/2 - 13 UNC	49 (66)	76 (103)	106 (144)
3/4	1/2 - 20 UNF	55 (75)	85 (115)	120 (163)
7/8	9/16 - 12 UNC	70 (95)	109 (148)	153 (207)
7/8	9/16 - 18 UNF	79 (107)	122 (165)	172 (233)
15/16	5/8 - 11 UNC	97 (131)	150 (203)	212 (287)
15/16	5/8 - 18 UNF	110 (149)	170 (230)	240 (325)
1-1/8	3/4 - 10 UNC	144 (195)	266 (360)	376 (509)
1-1/8	3/4 - 16 UNF	192 (260)	297 (402)	420 (569)
1-5/16	7/8 - 9 UNC	166 (225)	430 (583)	606 (821)
1-5/16	7/8 - 14 UNF	184 (249)	474 (642)	668 (905)
1-1/2	1 - 8 UNC	250 (339)	644 (873)	909 (1232)
1-1/2	1 - 12 UNF	274 (371)	705 (955)	995 (1348)
1-1/2	1 - 14 UNF	280 (379)	721 (977)	1019 (1381)
1-11/16	1-1/8 - 7 UNC	354 (480)	795 (1077)	1288(1745)
1-11/16	1-1/8 - 12 UNF	397 (538)	890 (1206)	1444 (1957)
1-7/8	1-1/4 - 7 UNC	500 (678)	1120 (1518)	1817 (2462)
1-7/8	1-1/4 - 12 UNF	553 (749)	1241 (1682)	2013 (2728)
2-1/16	1-3/8 - 6 UNC	655 (887)	1470 (1992)	2382 (3228)
2-1/16	1-3/8 - 12 UNF	746 (1011)	1672 (2266)	2712 (3675)
2-1/4	1-1/2 - 6 UNC	870 (1179)	1950 (2642)	3161 (4283)
2-1/4	1-1/2 - 12 UNF	979 (1327)	2194 (2973)	3557 (4820)

METRIC



Numbers appearing on bolt heads indicate ASTM class.

Proper torque for metric fasteners used on PECO equipment.
Recommended torque in foot pounds (newton Meters).*

WRENCH SIZE (mm) "A"	BOLT DIA. (mm) "B"	ASTM 4.6	ASTM 8.8	ASTM 9.8	ASTM 10.9
8	5	1.8 (2.4)		5.1 (6.9)	6.5 (8.8)
10	6	3 (4)		8.7 (12)	11.1 (15)
13	8	7.3 (10)		21.1 (29)	27 (37)
16	10	14.5 (20)		42 (57)	53 (72)
18	12	25 (34)	74 (100)	73 (99)	93 (126)
21	14	40 (54)	118 (160)	116 (157)	148 (201)
24	16	62 (84)	167 (226)	181 (245)	230 (312)
30	20	122 (165)	325 (440)		449 (608)
33	22		443 (600)		611 (828)
36	24	211 (286)	563 (763)		778 (1054)
41	27		821 (1112)		1138 (1542)
46	30	418 (566)	1119 (1516)		1547 (2096)

*Use 75% of the specified torque value for plated fasteners. Use 85% of the specified torque values for lubricated fasteners.

Troubleshooting

Collection System Performance

Problem	Possible Cause	Corrective Action
Abnormal Vibration	<ul style="list-style-type: none"> • Cutting blades are bent or unbalanced • Loose blower pulley or pulley assembly • Impeller blade out of balance 	<ul style="list-style-type: none"> • Install new cutting blade • Tighten the pulley • Contact dealer to replace
Reduced collection system performance	<ul style="list-style-type: none"> • Low engine speed • Plugged screen • Loose belt • Full collection bags 	<ul style="list-style-type: none"> • Always operate collection system at full throttle • Remove debris, leaves, or grass clippings from the screen • Replace belt • Empty the collection bags
Blower and hoses plugging too frequently	<ul style="list-style-type: none"> • Collection bags are too full • Low engine speed • Grass is too wet • Grass is too long • Ground speed is too fast • Worn belt • Loose belt 	<ul style="list-style-type: none"> • Dump more frequently • Always operate collection system at full throttle • Cut grass when it is dry • Cut the grass several times • Drive slower at full throttle • Replace belt
Debris blowout	<ul style="list-style-type: none"> • Collection bags are too full • Plug/clog in the collection system • Ground speed is too fast 	<ul style="list-style-type: none"> • Dump more frequently • Clean the collection system • Drive more slowly at full throttle
Impeller doesn't rotate freely	<ul style="list-style-type: none"> • Plug in the blower housing • Worn impeller blade • Shaft bearings bad/failing 	<ul style="list-style-type: none"> • Clean the blower housing • Contact dealer to replace • Contact dealer to replace

Cub Cadet®

Cub Cadet LLC

P.O. Box 361131
Cleveland, Ohio 44136-0019
Phone: 1-877-282-8684

MTD Products Limited

Kitchener, ON N2G 4J1
1-800-668-1238