

PROFESSIONAL BAGGING SYSTEM

MODEL# WBS2 / EBS

COUNTRY CLIPPER

ZERO TURN MOWER

DESIGNED FOR THE EDGE/EDGE XLT & WRANGLER



629GM-001A
EDGE & EDGE XLT

629GL-001A
WRANGLER

OPERATOR'S MANUAL

ASSEMBLY ● OPERATION ● MAINTENANCE

MANUAL#: Q0468 v3.1 - 9/7/2017

RESIDENTIAL BAGGING SYSTEM

TABLE OF CONTENTS

SECTION	PAGE	SECTION	PAGE
Safety	2	2-16 Boot To Mower Deck Installation	16
Safety Alert Symbols	3	2-17 Length Of Hose Adjustment	17
Warranty	4	2-18 Upper Hose Installation	17
I INTRODUCTION AND DESCRIPTION	5	2-19 Lower Hose To Blower Cone Installation	17
1-1 Introduction	5	2-20 Lower Hose To Boot Installation	17
1-2 Description	5	2-21 Impeller Blade Removal/Replacement	18
II INSTALLATION FOR USE	5	2-22 Weight Kit Installation	19-20
2-1 Preparation Of Mower	5-6	2-23 Installation/Removal of Collection Bags	21
2-2 Left & Right Frame Bracket installation	7	Exploded Views and Parts Lists	22-26
2-3 Rear Mount Plate Installation	8	III OPERATING INSTRUCTIONS	27
2-4 Rear Frame Mount Bracket Installation	9	3-1 General Safety	27
2-5 PTO Mount Plate Component Installation	10	3-2 Operation & Tips On Mowing	27
2-6 PTO Assembly & Exhaust Diverter Installation	11	3-3 Disengagement Of The Blower	27
2-7 Belt Installation and Adjustment	12	3-4 Unloading The Collection System	27
2-8 Blower Cone Installation	13	IV MAINTENANCE	27
2-9 Lower Mount tube Installation	13	4-1 Maintenance Checklist	27-28
2-10 Upper Frame Assembly Installation	14	4-2 Lubrication	28
2-11 Top Assembly To Upper Frame Assembly Installation	14	V PARTS AND SERVICE	28
2-12 Inlet Installation	14	5-1 Parts And Service Information	28
2-13 Hinge Kit Assembly Installation	15	Safety Decals	29
2-14 Blow-By Bracket Installation	16	Torque Specifications	30
2-15 Boot To Mower Deck Installation	16		

Safety

1. Read the operator's manual carefully and familiarize yourself with the proper use of your attachment. Do not allow anyone who is not acquainted with the Safety Instructions to use your attachment.
2. Know the controls and how to stop quickly. READ THE OPERATOR'S MANUAL!
3. Do not allow children to operate the vehicle. Do not allow adults to operate it without proper instruction.
4. Be especially watchful of children and pets darting into the area while operating.
5. Keep your eyes and mind on your unit while mowing or operating your attachment. Don't let others distract you.
6. Do not attempt to operate your unit or mower when not in the driver's seat.
7. Always stop unit when emptying the container.
8. Stop unit, shut off deck attachment, set parking brake, shut off mower engine and remove spark plug wire before removing clogs, removing or replacing hose, boot, blower cone, or performing any maintenance.
9. Mow across the face of slopes (not steeper than 10 degrees); never up and down the face.
10. It is recommended that the container be kept only half full when negotiating any slopes. Start mowing on slopes when the container is empty.
11. Inspect your lawn and remove any foreign objects before mowing. Never deliberately run the mower across any foreign object.
12. Wear ear protection if the noise level is offensive.
13. Wear eye protection to prevent debris from damaging your eyes.

SAFETY

WARNING! NEVER operate the mower unless the discharge guard and either the deflector assembly or the vacuum collector adapter are fastened securely in place.

WARNING! Do not work around the mower deck boot or the blower area until you are certain that the mower blades and the blower impeller have stopped rotating.

WARNING! To avoid serious injury, perform maintenance on the vacuum collector; **ONLY AFTER STOPPING THE MOWER'S ENGINE AND WAITING FOR ALL MOVING PARTS TO COME TO A COMPLETE STOP.** Set the parking brake. Always remove the ignition key before beginning maintenance.

WARNING! For your own personal safety, **ALWAYS** mow **ACROSS** the face of slopes and **NEVER UP and DOWN** the face. **NEVER** attempt to mow excessively steep slopes, and use caution when turning on any slope.

Safety Alert Symbol



This Safety Alert Symbol means: **“ATTENTION! BECOME ALERT! YOUR SAFETY IS INVOLVED!”**

This symbol is used to call attention to safety precautions that should be followed by the operator to avoid accidents. When you see this symbol, carefully read the message that follows and heed its advice. Failure to comply with safety precautions could result in death or serious bodily injury.

Safety Signs

The signal words **DANGER**, **WARNING**, and **CAUTION** are used on the equipment safety signs. These words are intended to alert the viewer to the existence and the degree of hazard seriousness.



White letters on **RED**

This signal word indicates a potentially hazardous situation which, if not avoided, will result in death or serious injury.



Black letters on **ORANGE**

This signal word indicates a potentially hazardous situation which, if not avoided, could result in death or serious injury.

It may also be used to alert against unsafe practices.



Black letters on **YELLOW**

This signal word indicates a potentially hazardous situation exist which, if not avoided, will result in minor or moderate injury.

It may also be used to alert against unsafe practices.

COUNTRY CLIPPER LIMITED WARRANTY FOR NEW PRODUCTS

A. WHAT IS WARRANTED? Country Clipper extends the following warranties to the original purchaser of each new Country Clipper bagging system subject to the following limitations:

1. PRODUCT WARRANTY: Any part of the bagging system, which is defective in material or workmanship as delivered to the purchaser will be repaired or replaced, as Country Clipper elects, without charge for parts or labor, if the defect appears within 12 months from the date of delivery of the product to the original purchaser. **ALL DEFECTIVE PARTS MUST BE RETURNED TO COUNTRY CLIPPER FOR INSPECTION TO DETERMINE VALIDITY OF WARRANTY CLAIMS.** Freight and mailing will be borne by the customer.

2. PARTS REPLACED DURING WARRANTY: Any new Country Clipper bagging system which is furnished in performance of this warranty and is defective in material or workmanship as delivered to the purchaser will be repaired or replaced, as Country Clipper elects, without charge if the defect appears within 90 days from the date of installation of such part or before the expiration of the original warranty period, whichever is later.

B. SECURING WARRANTY ADJUSTMENTS: Call Country Clipper for Return Authorization. Damaged or broken parts, other than engines or batteries, must be returned to Country Clipper Division of Shivers Mfg. Inc., 613 W. English, Corydon, IA, 50060 before any warranty adjustment can be authorized. At the time of requesting warranty adjustment, the purchaser must present evidence for date of delivery of the product. The purchaser shall pay any charge for the product to and from Corydon, IA.

C. ITEMS NOT COVERED BY COUNTRY CLIPPER WARRANTY: Engines, batteries, and gearboxes attached to Country Clipper products are covered under a separate warranty by the respective manufacturer.

D. UNAPPROVED ALTERATION OR MODIFICATION: All obligations of Country Clipper, under this warranty, shall be terminated if products are altered or modified in ways not approved by Country Clipper.

E. ACCIDENTS AND NORMAL MAINTENANCE: The warranty covers only defective material and workmanship. It does not cover depreciation or damage caused by normal wear, accident, improper use or abuse of products. The cost of normal maintenance and normal replacement of service items such as belts, cutting blades, hoses, etc., which are not defective shall be paid for by the purchaser.

F. NO REPRESENTATIONS ADDITIONAL WARRANTIES, DISCLAIMER: Neither Country Clipper nor any company affiliated with it makes any warranties, representations or promises as to the quality of performance of its products other than those set forth herein. Except as described above, Country Clipper makes no other warranties **AND SPECIFICALLY DISCLAIMS ANY AND ALL IMPLIED WARRANTIES OF FITNESS AND MERCHANTABILITY.**

G. ANY MACHINE USED FOR RENTAL PURPOSES ARE GUARANTEED FOR 45 DAYS FROM DATE OF ORIGINAL SALE ONLY.

H. REMEDIED EXCLUSIVE: The only remedies the purchaser has in connection with the breach or performance of any warranty on Country Clipper bagging systems are set forth above. In no event will Country Clipper be liable for special incidental or consequential damages.

1. NO SERVICE CENTER WARRANTY: The selling Service Center makes no warranty on his own on any item warranted by Country Clipper unless he delivers to purchaser a separate written warranty certificate specifically warranting the item. The dealer has no authority to make any representation or promise on behalf of Country Clipper or to modify the terms of this warranty in any way.

Section I

INTRODUCTION & DESCRIPTION

1-1 Introduction

Your grass collection system has been designed to give you a low maintenance, simple, and effective way to collect the grass clippings from your mower. This manual is provided to give you the necessary instructions to properly mount and operate the collection system on your mower. Please read this manual thoroughly. Understand what each control is for and how to use it. Observe all safety decal precautions on the machine and noted throughout the manual.

NOTE: All references made to right, left, front, rear, top or bottom are as viewed from the normal operator's position on the mower.

1-2 Description

The grass collection system is designed for turf maintenance where there is a need to collect the grass clippings as the mower cuts the turf. It is also used for picking up leaves in pre-season and post-season clean-up. The blower, mounted on the right side of the unit, uses a belt and gearbox system from the engine PTO shaft. Drive train protection comes through belt slippage. The blower draws grass clippings from the discharge area of the cutting deck back to the (2) - 4 cubic foot collection bags P#(G0003) at the rear portion of the mower frame. The operator can engage the blower with a spring-lock engagement handle on the right side of the unit. Once the bags are full with clippings, they can be easily released for dumping.

Section II

INSTALLATION FOR USE

2-1 Preparation Of Mower

Remove the PTO belt. From the underside of the engine, disconnect the wiring harness attached to the electric clutch. Remove the bolt and electric clutch from the mower. Remove the D-drive spacer using an arbor press or equivalent. On removal, adjacent bearing OUTER race must be supported or bearing damage may occur. Refer to Figure 2-1a.

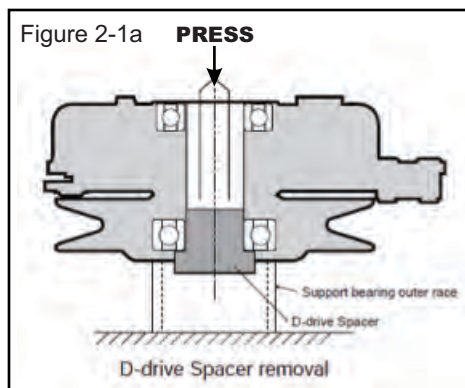

The engine pulley bushing must be installed using an arbor press or equivalent. Upon installation, opposite bearing inner race must be supported or bearing damage may occur. Refer to Figure 2-1b.

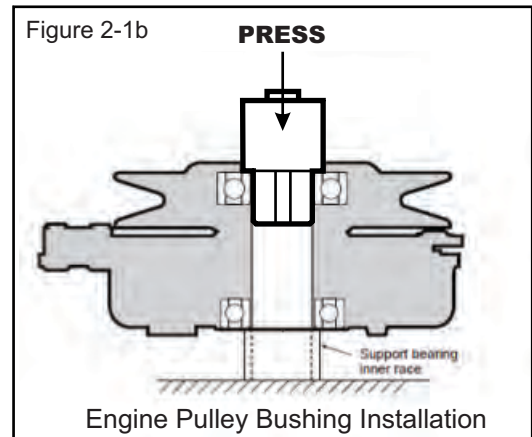

NOTE: Refer to your Country Clipper parts manual for reference during this step.

Detach the deck tension spring shown in Figure 2-1d, on page 6. Remove the engine guard, bumper braces and muffler guard (if equipped) from the rear frame of the mower. Save the hardware for use during the frame bracket installation. Refer to Figure 2-1d on page 6 for reference.

Once the Engine Pulley Bushing is installed, reattach the clutch assembly to the mower and then review Figure 2-1c.

Wrangler Series

Fasten the engine pulley bushing stamped with #12 P#(S0197) to the electric clutch assembly using (1) Clamp Washer P#(K0278), (1) 7/16" lock washer P#(K0140), and 7/16"-20 x 4" hex bolt P#(K0359). Torque the bolt to 55 ft./lbs. The added pulley will power the collection system and should resemble Figure 2-1e when installed.

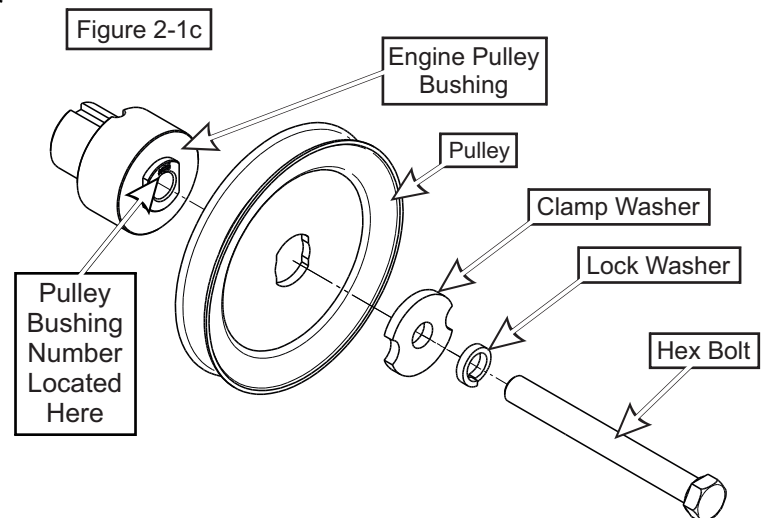

2-1 Preparation of Mower Cont.

Edge Series w/ KW FS651V

Fasten the engine pulley assembly stamped with #12 P#(S0197) to the electric clutch assembly using (1) Clamp Washer P#(K0278), (1) 7/16" lock washer P#(K0140), and 7/16"-20 x 4" hex bolt P#(K0359). Torque the bolt to 55 ft./lbs. The added pulley will power the collection system and should resemble Figure 2-1e when installed.

Edge Series w/ 27HP Kohler & Edge XLT Series

Fasten the engine pulley assembly stamped with #6 P#(S0191) to the electric clutch assembly using (1) Clamp Washer P#(K0278), (1) 7/16" lock washer P#(K0140), and 7/16"-20 x 4" hex bolt P#(K0359). Torque the bolt to 55 ft./lbs. The added pulley will power the collection system and should resemble Figure 2-1e when installed.

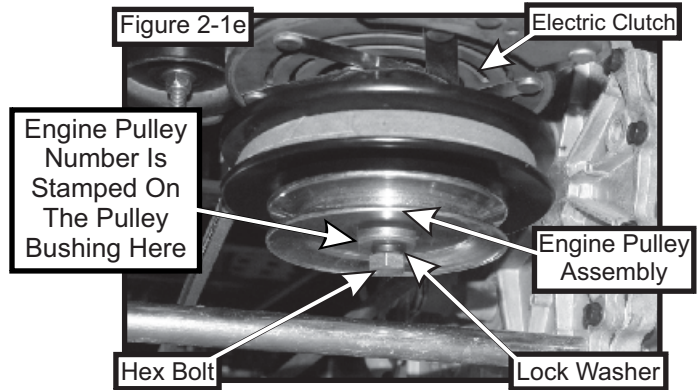
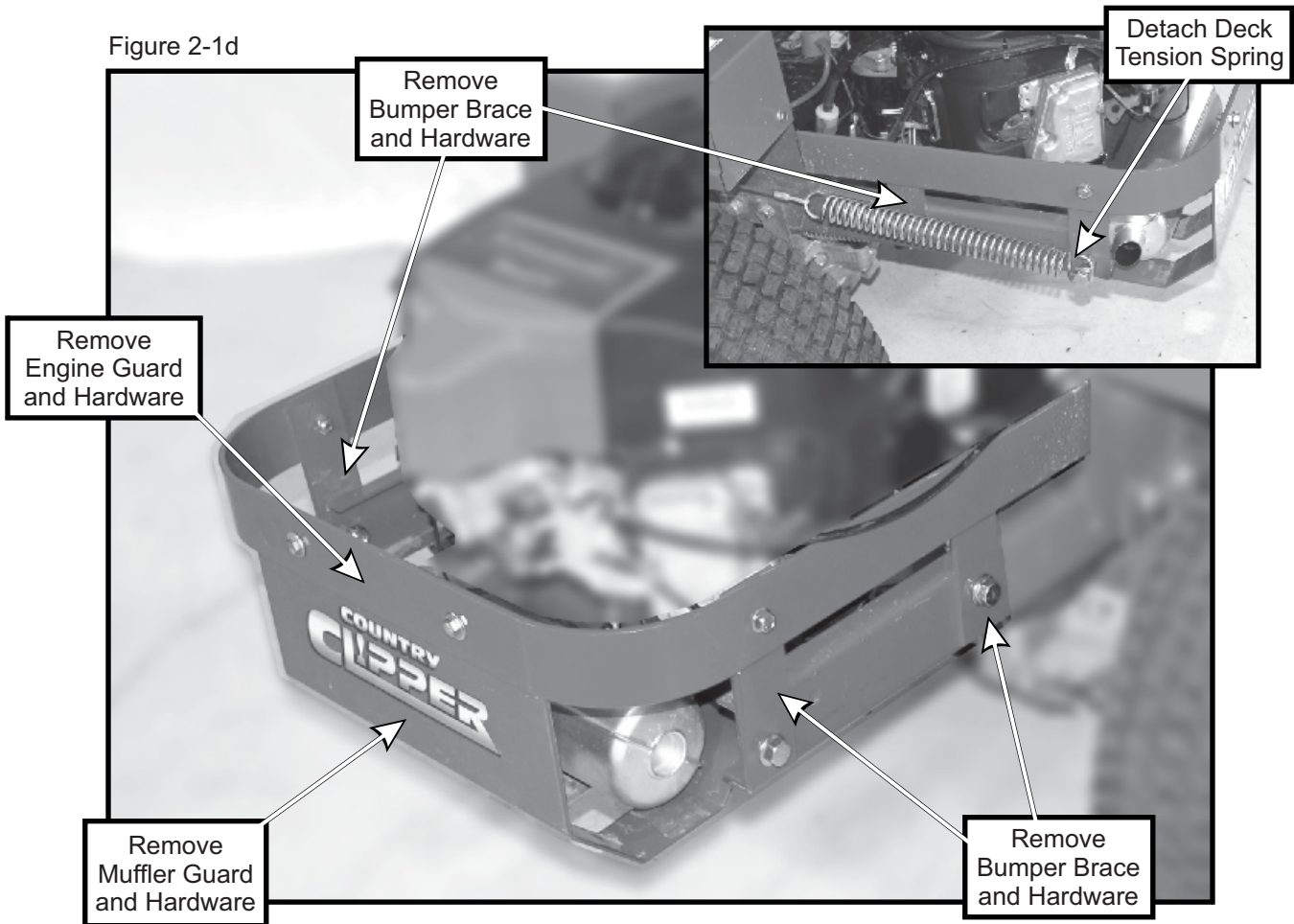
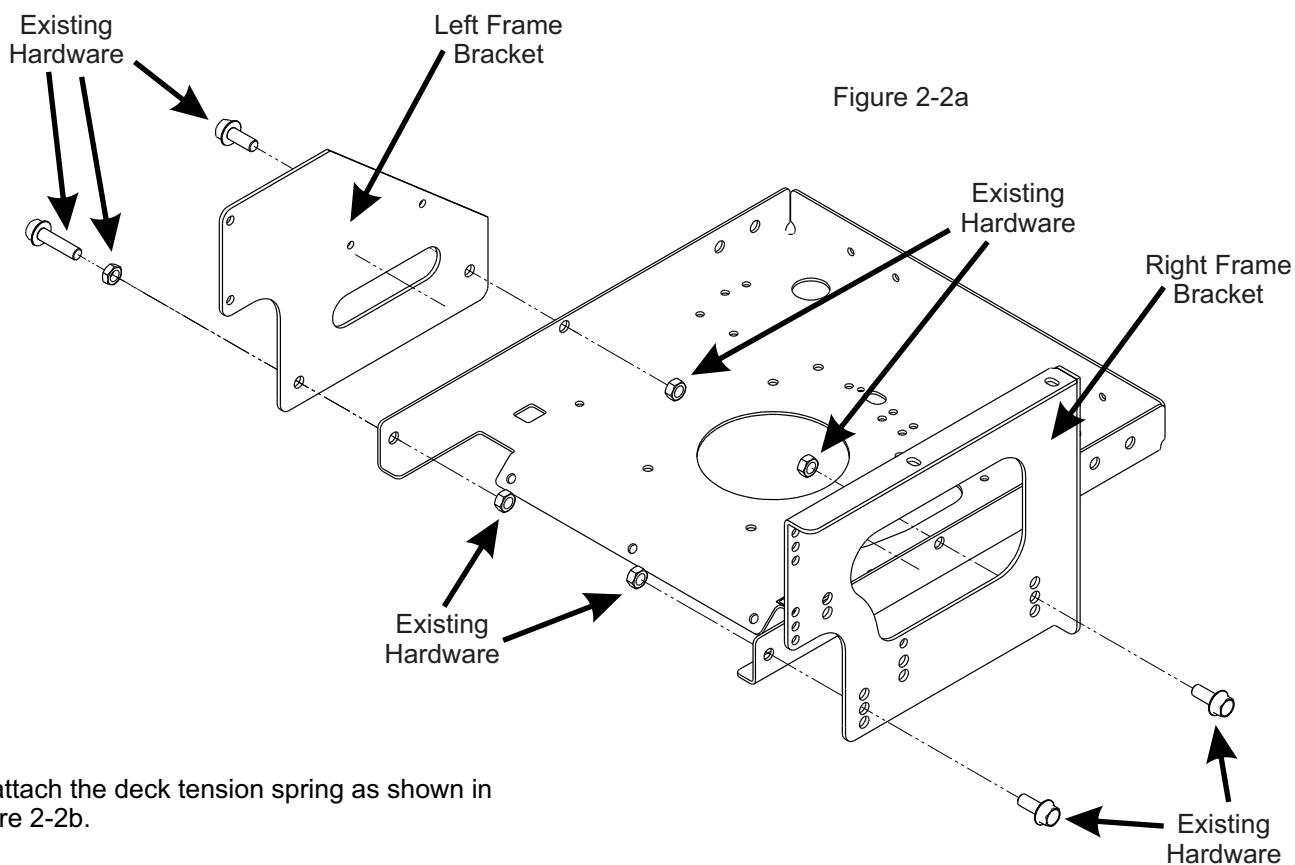

Figure 2-1d



2-2 Left and Right Frame Bracket Installation

Secure the left frame bracket P#(B0809) and right frame bracket P#(B0810) to the rear frame of the mower using the hardware removed from the engine guard. Refer to Figure 2-2a.



Re-attach the deck tension spring as shown in Figure 2-2b.

Figure 2-2b

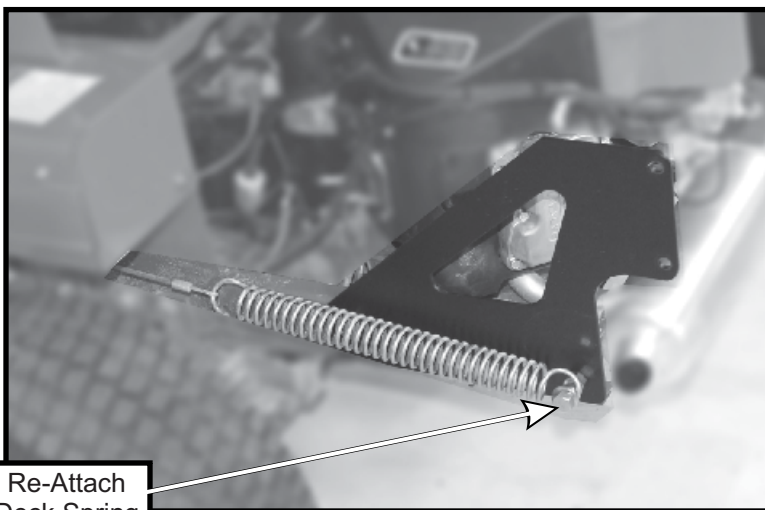

2-3 Rear Mount Plate Installation

Install the rear mount plate to the left and right frame bracket using (4) 3/8"-16 x 1" HHCS P#(K1191) and (4) 3/8"-16 nylon flange locknuts P#(K2038) as shown in Figure 2-3a.

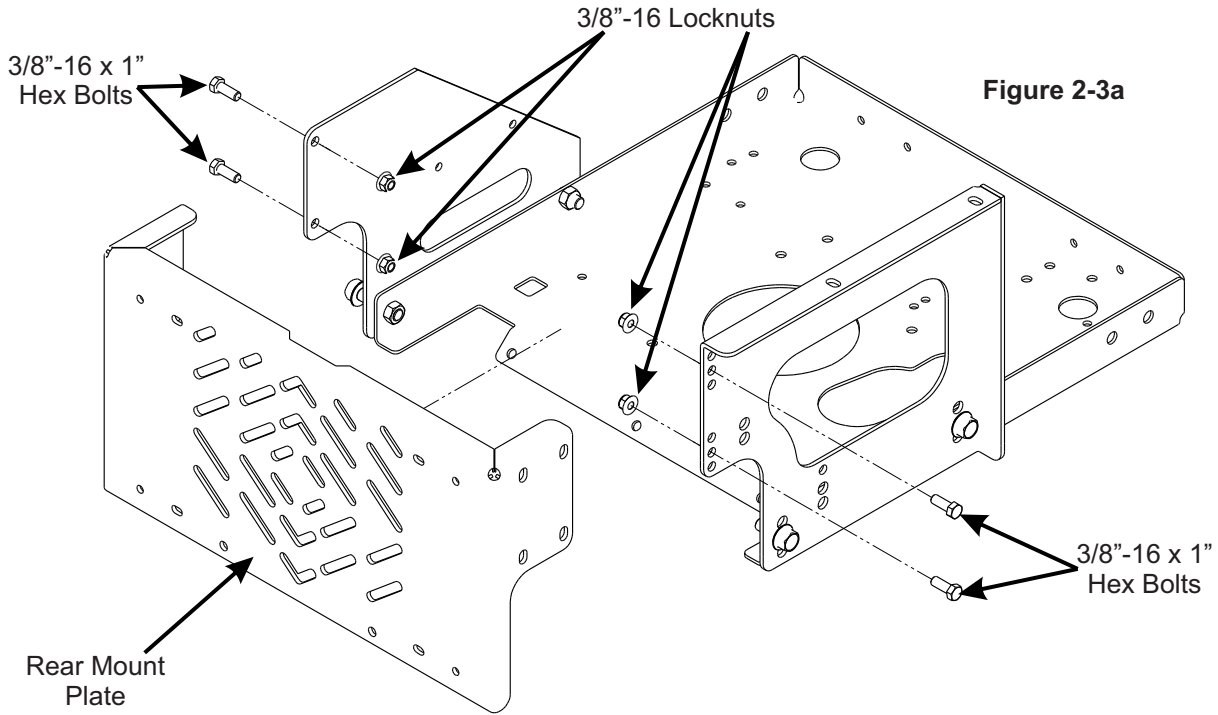

Refer to Figure 2-3b for mounting hole locations specific to your engine option.

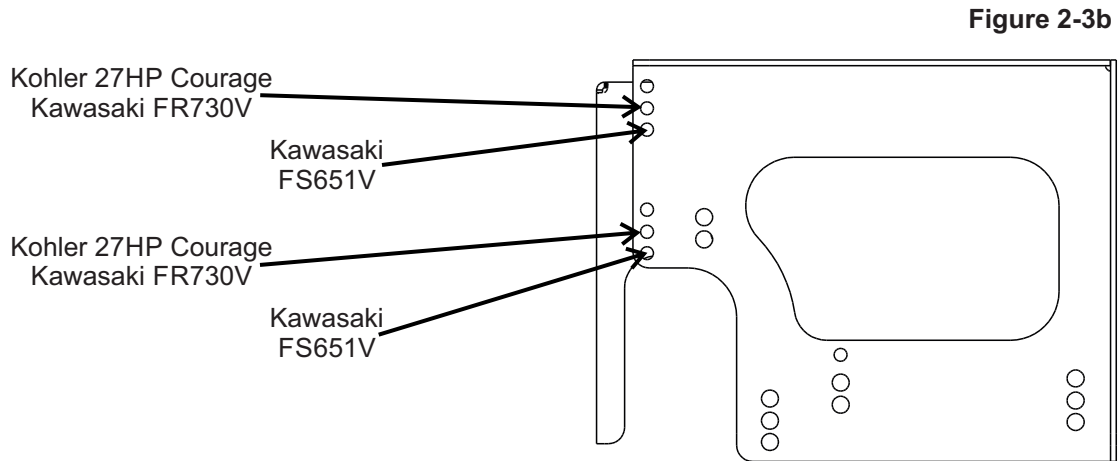

2-4 Rear Frame Mount Bracket Installation

Wrangler Kawasaki FS651V

Insert the rear frame mount bracket P#(B0818) into the notch on the motor mount weldment as shown in Figure 2-4a. Secure the rear frame mount bracket to the rear mount plate using (2) 3/8"-16 x 1" HHCS P#(K1191) and (2) 3/8"-16 nylon flange locknuts P#(K2038). Refer to Figure 2-4b. The rear mount plate has been exploded in this figure to aid in visual clarity, for mounting purposes.

Figure 2-4a

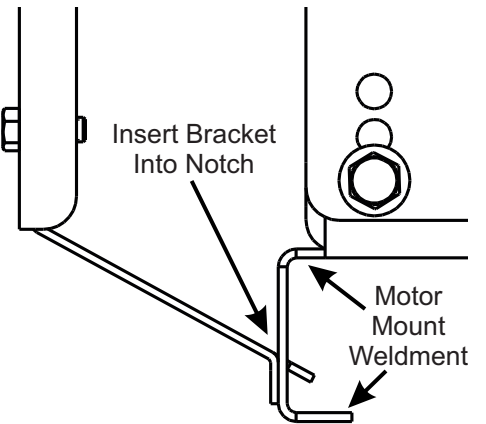
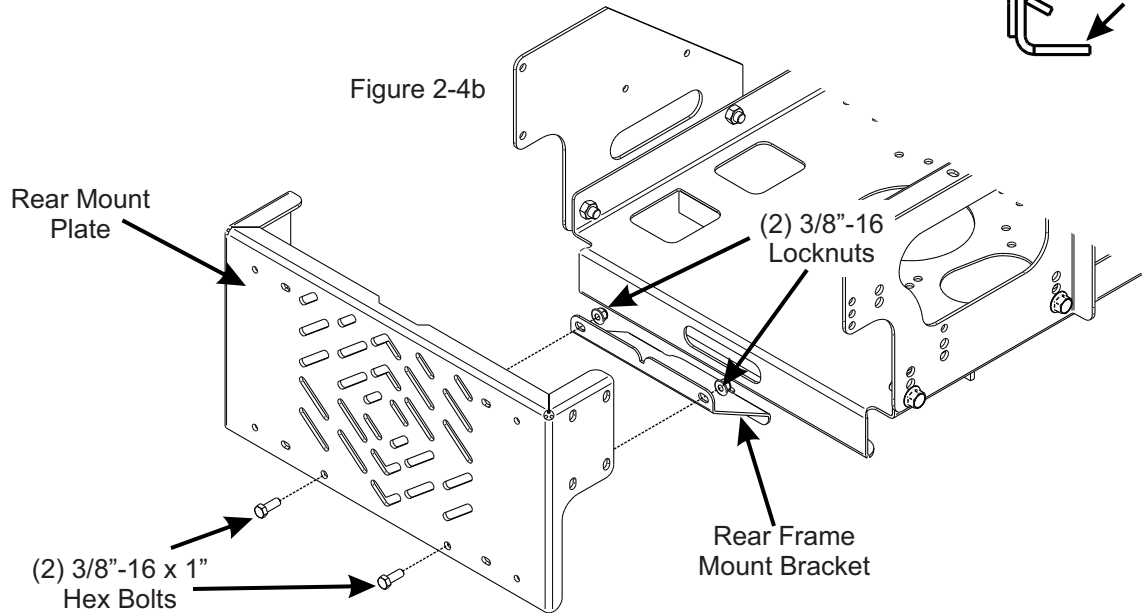

Figure 2-4b



Wrangler Kohler 22HP Edge / Edge XLT Kohler 22HP & 27HP Kawasaki FS651V & FR730V

Replace the muffler guard removed in Section 2-1 with the rear frame mount bracket P#(B0817). Secure the bracket to the motor mount weldment using the existing hardware from the muffler guard. Secure the bracket to the rear mount plate using (2) 3/8"-16 x 1" HHCS P#(K1191) and (2) 3/8"-16 nylon flange locknuts P#(K2038). Refer to Figure 2-4c. The rear mount plate has been exploded in this figure to aid in visual clarity, for mounting purposes.

Figure 2-4c

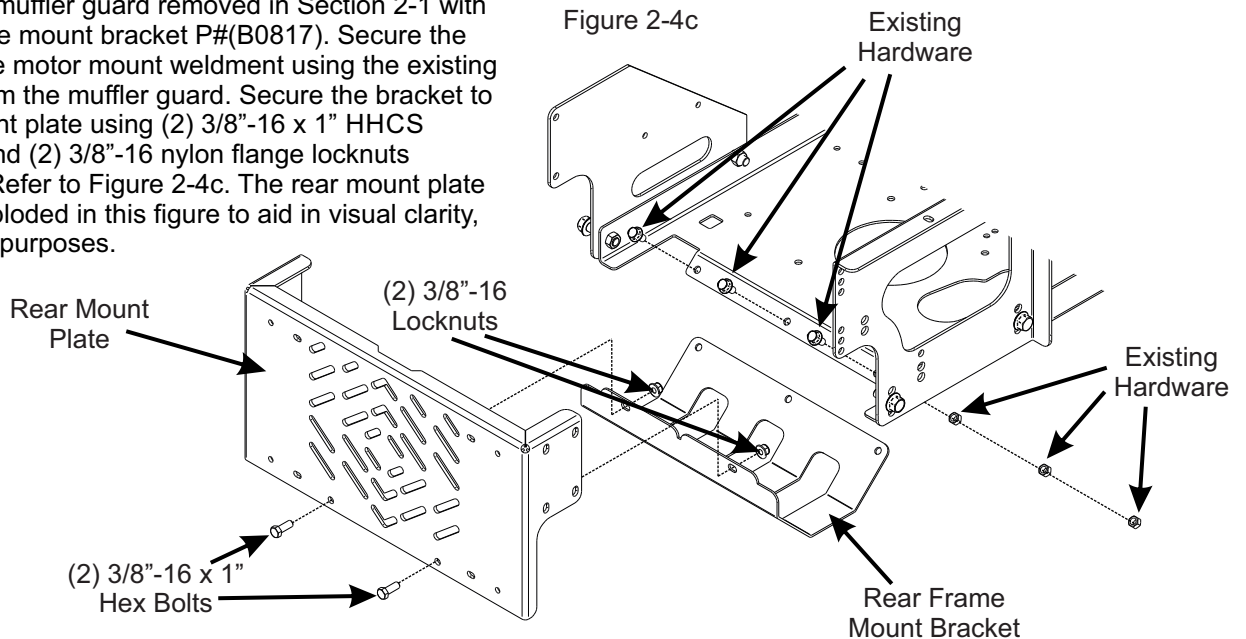

2-5 PTO Mount Plate Component Installation

Secure the left PTO mount plate P#(B0811) to the right frame bracket using (2) 3/8"-16 x 1" HHCS P#(K1191), (2) 3/8" flat washers P#(K0047) and (2) 3/8"-16 nylon flange locknuts P#(K2038). Leave the hardware slightly loose until the PTO stop plate is installed. Secure the right PTO mount plate P#(B0812) to the right frame bracket using (1) 3/8"-16 x 1" HHCS P#(K1191), (1) 3/8" flat washers P#(K0047) and (1) 3/8"-16 nylon flange locknuts P#(K2038).

Secure the lower mount hole on the right PTO mount plate with existing 1/2"-13 hex bolt and nut removed from the bumper brace. Secure the PTO stop plate P#(B0733) to the left and right PTO mount plates using (4) 1/4"-20 x 3/4" HHCS P#(K1222) and (4) 1/4"-20 nylon flange locknuts P#(K2014). Refer to Figure 2-5a. Tighten all PTO component hardware at this time.

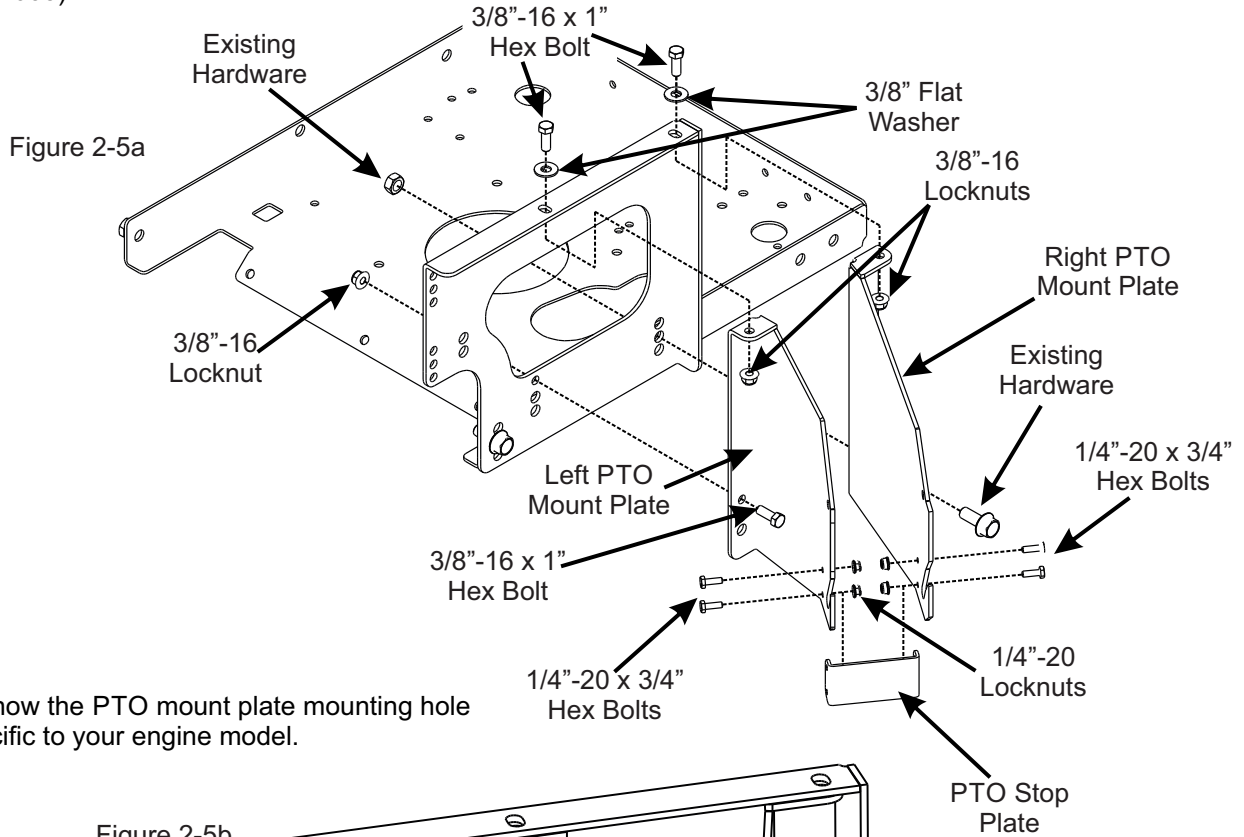
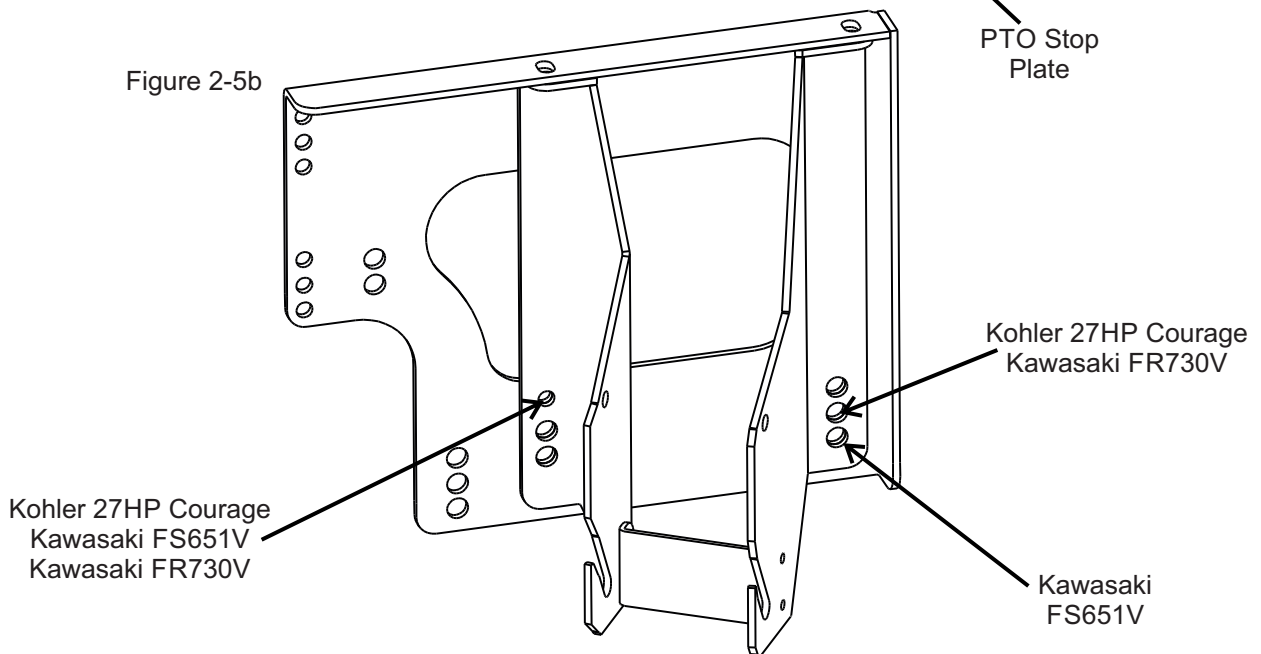

Figure 2-5b show the PTO mount plate mounting hole locations specific to your engine model.



2-6 PTO Assembly Installation & Exhaust Diverter Installation

Insert the PTO Assembly P#(A1840) into the PTO mount plates. Remove the gearbox pulley guard and wrap the kevlar belt P#(M0248) around the engine pulley and gearbox pulley. Rotate the PTO assembly towards the mower frame and align the mount holes in the PTO assembly with the mount holes in the PTO mount plates. Secure the PTO assembly with (1) PTO mount pin P#(B0274) and (1) hair pin clip P#(K0086). Replace the gearbox pulley guard. Refer to Figure 2-6a. Follow the procedures in Section 2-7 for proper belt tensioning.

Wrangler Series with 22HP Kohler Courage engines must have an exhaust diverter P#(J0293) installed. Position the exhaust diverter so that the exhaust is not blowing on the collection bags or the ground. Secure the diverter with (1) exhaust clamp P#(X1064). Refer to Figure 2-6b.

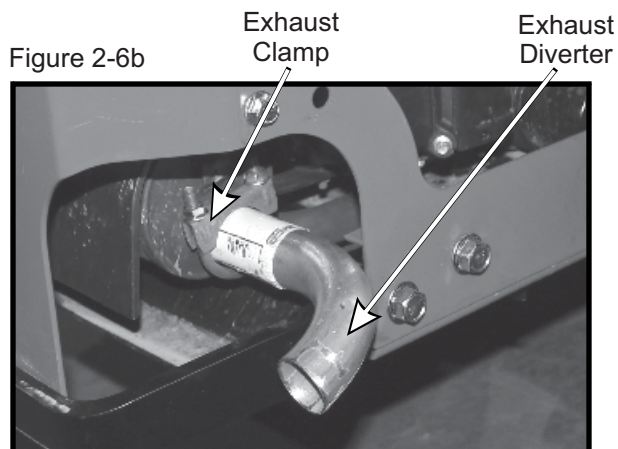
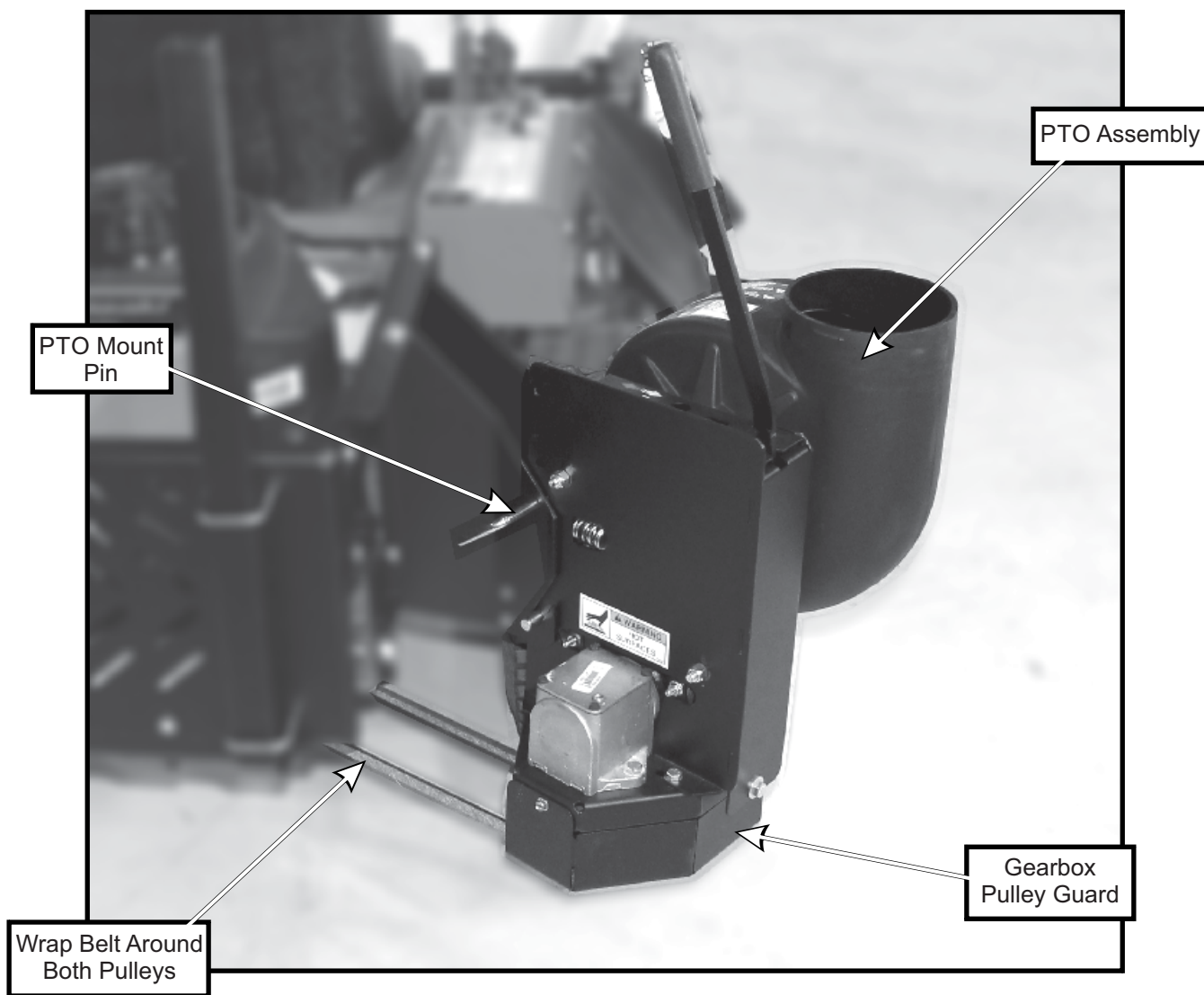

Figure 2-6a



2-7 Belt Installation/Removal and Adjustment

Remove (3) 1/4"-20 x 1/2" HHSTS P#(K0353) from the gearbox pulley guard located on the bottom of the PTO assembly as shown in Figure 2-7a.

Figure 2-7a

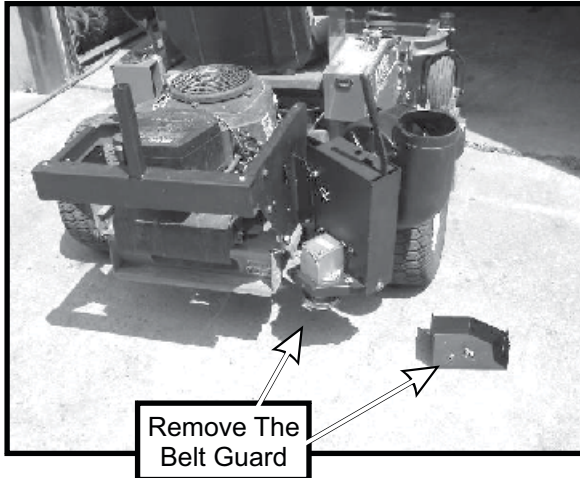

Loosen the (4) 5/16"-18 x 3/4" HHCS P#(K1153) that secure the gearbox assembly to the PTO assembly. Loosen the belt tension adjustment bolt (1) 3/8"-16 x 2" HHCS P#(K1208). Refer to Figure 2-7b and 2-7c.

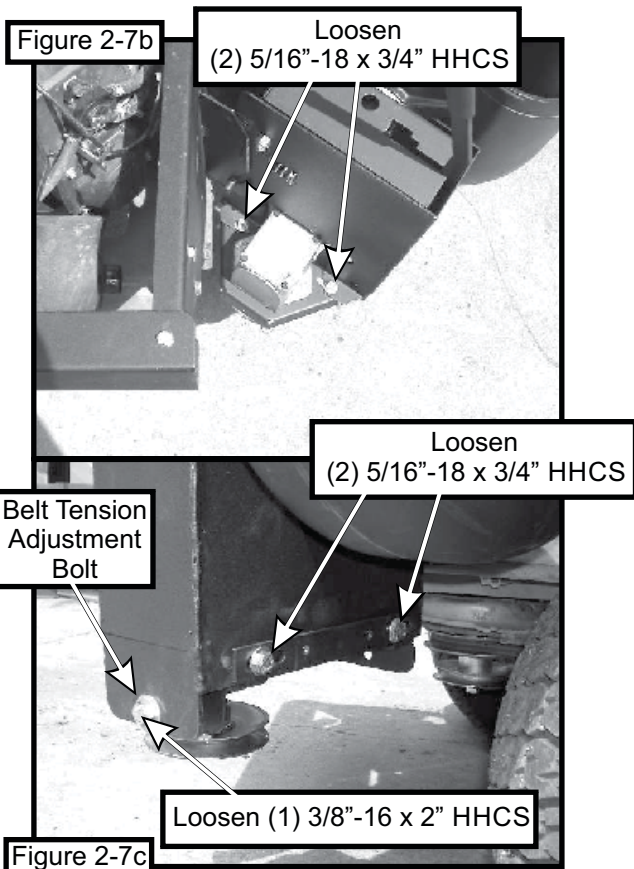

After loosening the hardware in Figure 2-7b and 2-7c, slide the gearbox to the farthest left position (towards the engine). Wrap one end of the kevlar belt P#(M0248) around the engine pulley. Wrap the other end of the belt around the pulley on the gearbox. Refer to Figure 2-7d for reference.

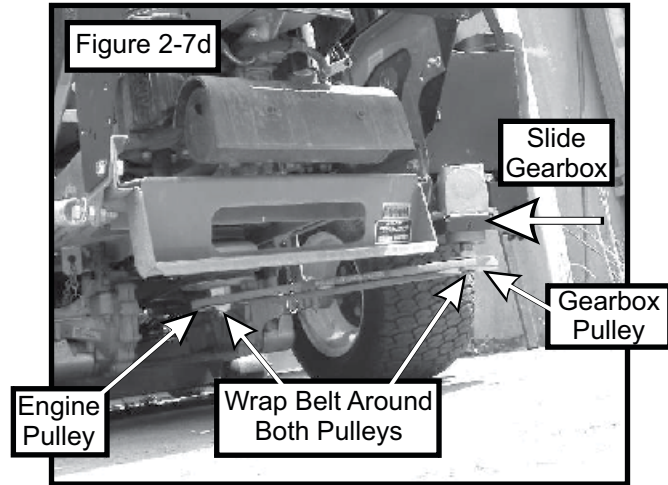

With the kevlar belt wrapped around both pulleys, tilt the PTO assembly towards the mower frame and align the mount holes in the PTO assembly with the mount holes in the PTO mount plates. Secure the PTO assembly with (1) PTO mount pin P#(B0274) and (1) hair pin clip P#(K0086). Replace the gearbox pulley guard. Refer to Figure 2-7e.

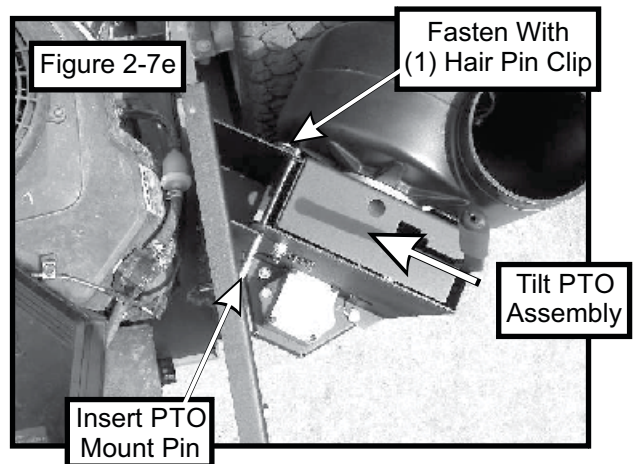

To properly tension the belt, turn the adjustment bolt clockwise until there is 1" of deflection when 10-11 pounds of pressure is applied to the center of the belt (between both pulleys). After tensioning, tighten the (4) 5/16"-18 x 3/4" HHCS P#(K1153) from Figure 2-7b and 2-7c, that secure the gearbox to the PTO assembly. Replace the gearbox pulley guard and (3) 1/4"-20 x 1/2" HHSTS P#(K0353).

2-7 Blower Cone Installation

Secure the 8" aluminum blower cone P#(E8004) to the plastic blower housing, using (3) 1/4"-20 x 3/4" HHCS P#(K1222), (3) 1/4" lock washers P#(K0039) and (3) 1/4" flat washers P#(K0037). Refer to Figure 2-8.

Figure 2-8

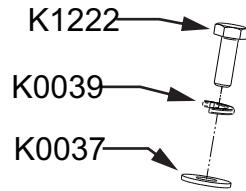

2-9 Lower Mount Tube Installation

Secure the lower mount tubes P#(B0752) to the rear mount bracket using (2) 5/16"-18 x 2-1/4" u-bolts P#(K1098) and (4) 5/16"-18 nylon flange locknuts P#(K2516) PER TUBE. The bottom edge of the lower mount tubes should be flush with the top edge of the bumper guard before the hardware is tightened. Refer to Figure 2-9.

Figure 2-9

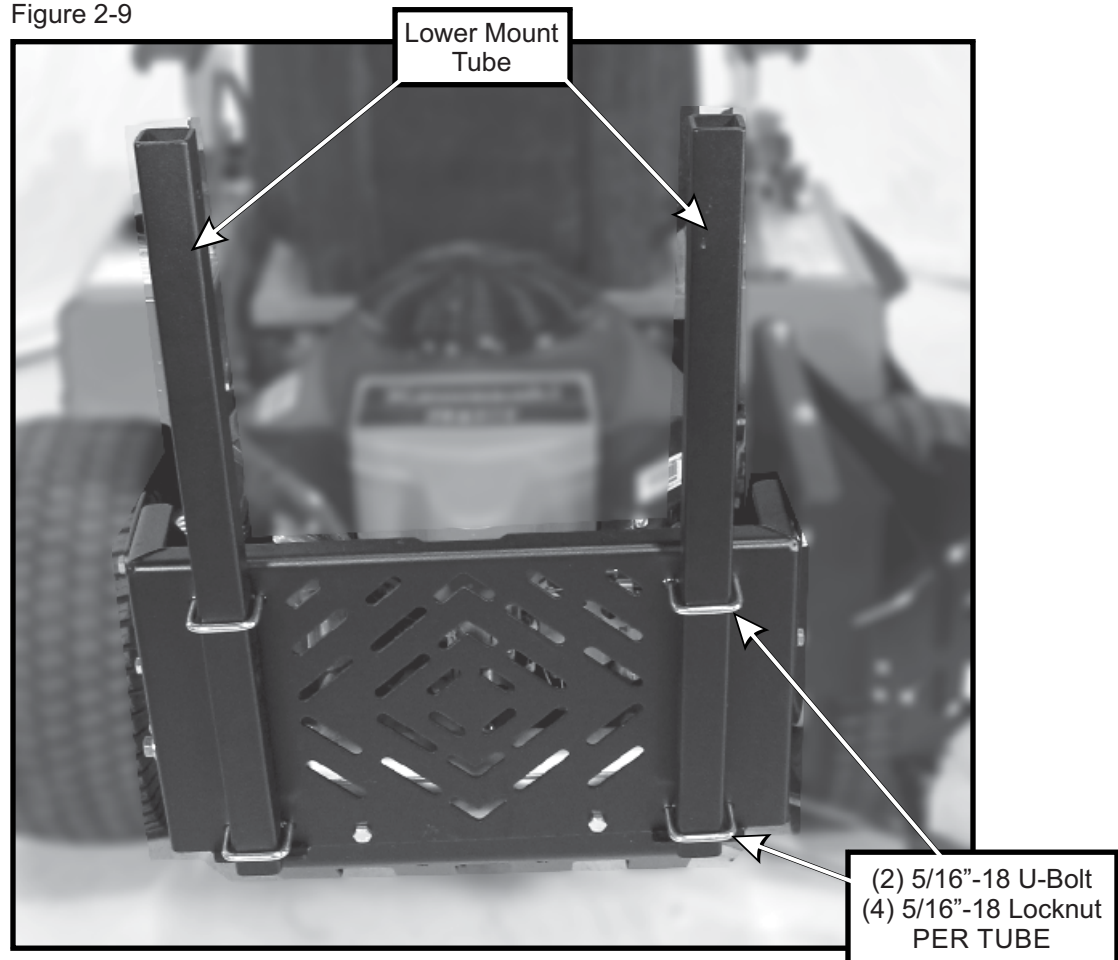

2-10 Upper Frame Assembly Installation

Position the upper frame assembly P#(A1114) above the lower mount tubes as shown in Figure 2-10. Lower the upper frame assembly onto the lower mount tubes and secure using (2) clevis pins P#(K0133) and (2) hair pin clip P#(K0088).

Figure 2-10

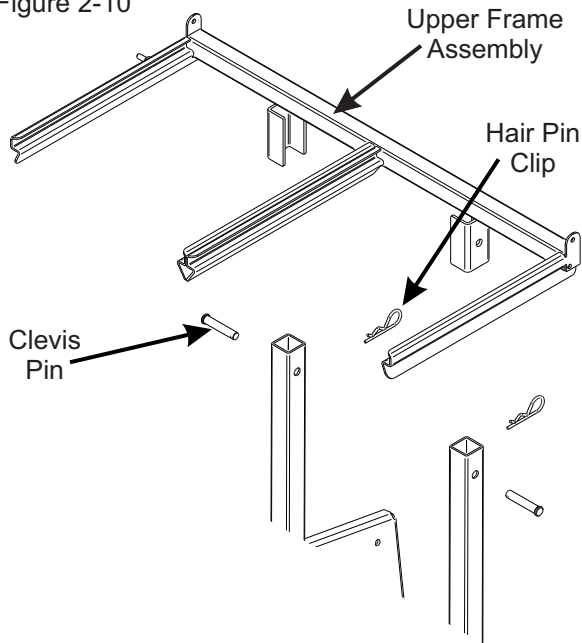

2-11 Top Assembly To Upper Frame Assembly Installation

Position the top assembly P#(A1938) above the upper frame assembly as shown in Figure 2-11. Fasten the top assembly to the upper frame assembly using (2) 5/16"-18 x 2-1/2" HHCS P#(K0125) and (2) 5/16"-18 nylon flange locknuts P#(K2516). Leave the locknuts slightly loose, to allow the top assembly to open and close easily. Refer to Figure 2-11 for hardware location.

2-12 Inlet Installation

Insert the Inlet P#(V0019) into the hole on the top assembly from the inside and then snap the inlet into place. The inlet should pivot freely about the hole.

Figure 2-11

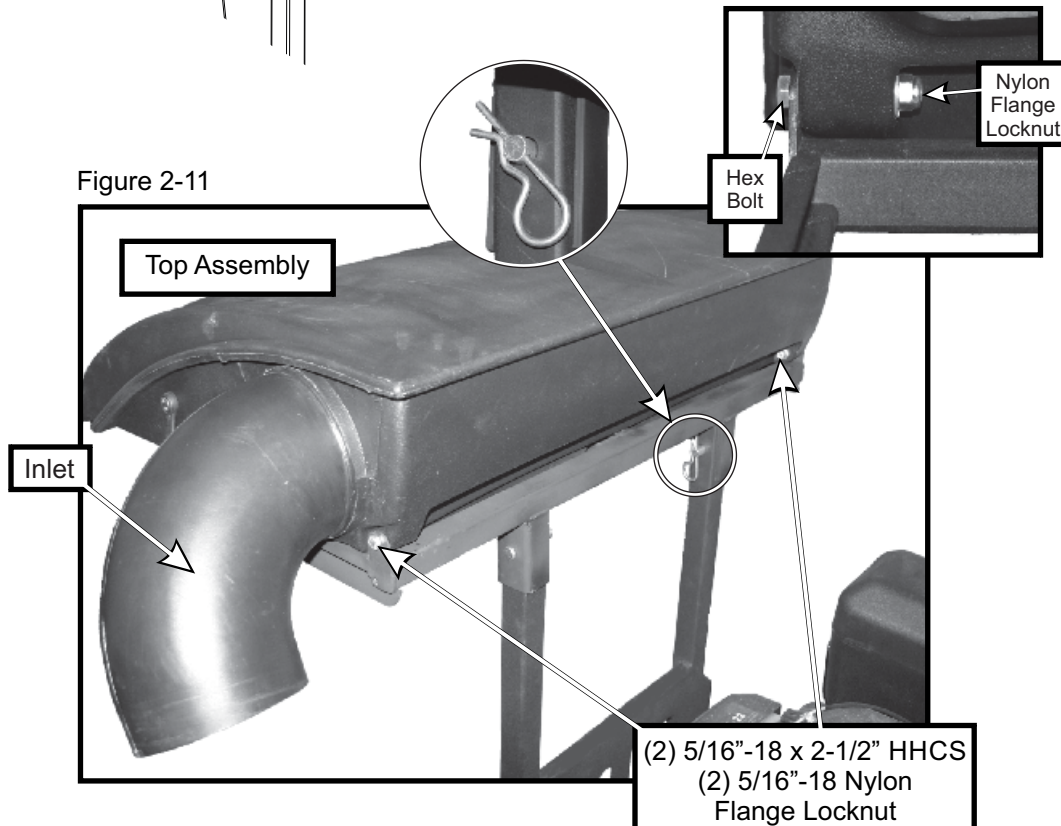

2-13 Hinge Kit Assembly Installation

Assemble the hinge kit as shown in Figure 2-13, using (2) 5/16"-18 x 1" HHCS P#(K1154), (3) 5/16"-18 nylon flange locknuts P#(K2516), (5) 1/4" flat washers P#(K0037) and (2) swing arm brackets P#(ZT-0004). Place (1) vinyl cap P#(J0289) on the end of the hex bolts as shown in Figure 2-13. Leave the nuts loose enough to allow fluid movement of the top when opening and closing. When opened, the top should rest on the middle joint of the hinge allowing it to remain up.

Figure 2-13

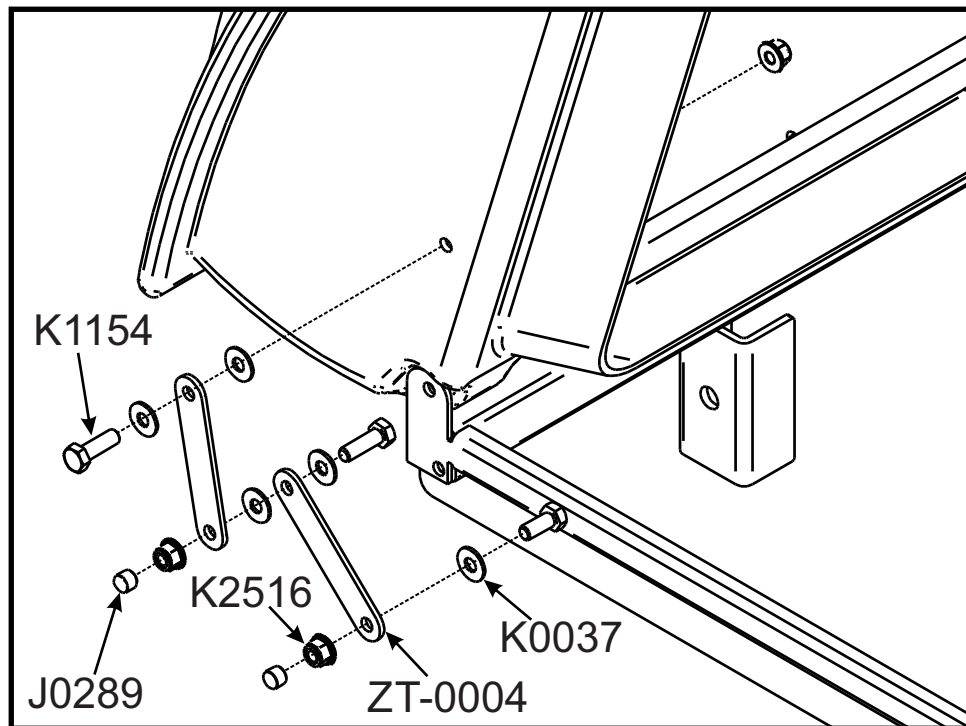

2-14 Blow-By Bracket Installation

48" & 52" Decks

Secure the blow-by bracket to the discharge chute of the mower deck as shown in Figure 2-14, using (1) 5/16"-18-3/4" HHCS (P#(K1153), (1) 5/16" lock washer P#(K0043), (1) 1/4" flat washer P#(K0037) and existing nut from the discharge chute.

Figure 2-14

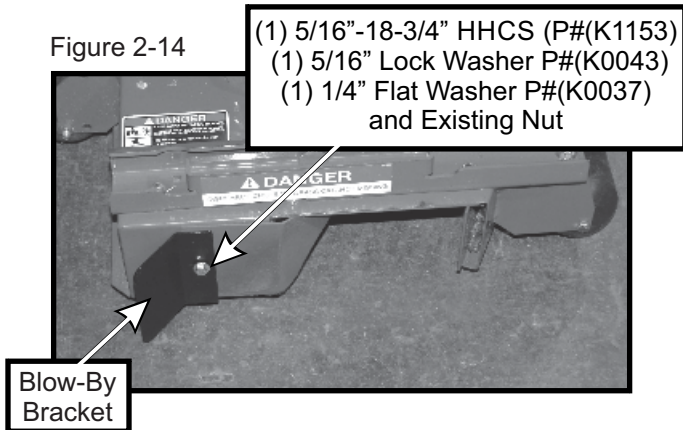

2-15 Boot Plate Installation

Secure the boot plate P#(B0820) to the aluminum boot P#(E1902) using (2) 3/8"-16 x 1" carriage bolts P#(K1182) and (2) 3/8"-16 nylon flange locknuts P#(K2038). Insert the carriage bolts from the inside of the boot so the threads are on the top of the boot. This will prevent grass clippings from collecting on the threads. Leave the hardware loose until the boot plate has been attached to the mower deck. Refer to Figure 2-15a and 2-15b for reference.

Figure 2-15a

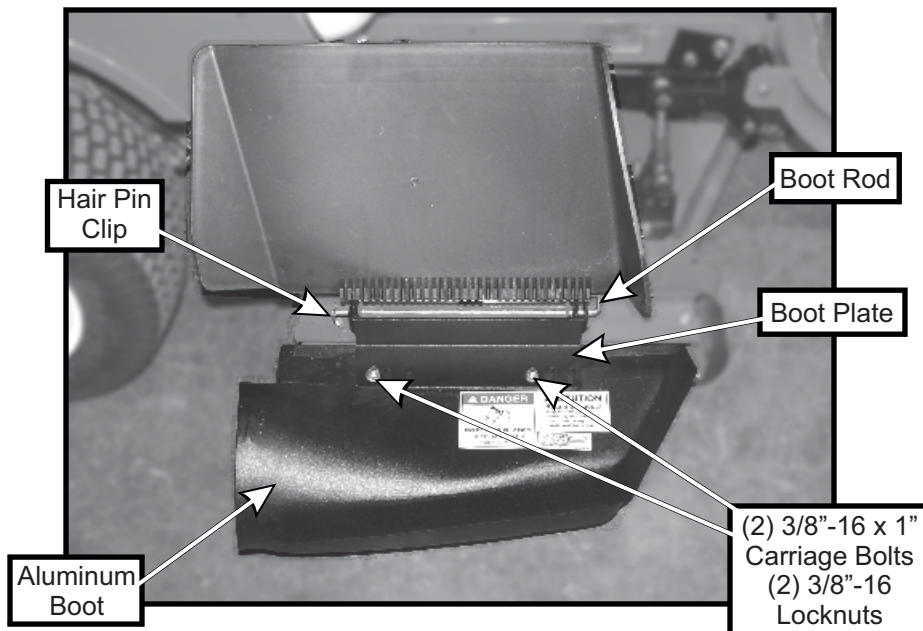

2-16 Boot To Mower Deck Installation

Remove the hardware from the grass deflector and insert (1) boot rod P#(B4331) into the grass deflector mounting holes as shown in Figure 2-15a. Secure the boot rod using (1) hair pin clip P#(K0099). With the carriage bolts from Section 2-15 still loose, adjust the position of the boot so that there is no gap between the mower deck and the boot. Tighten the hardware at this time.

Figure 2-15b

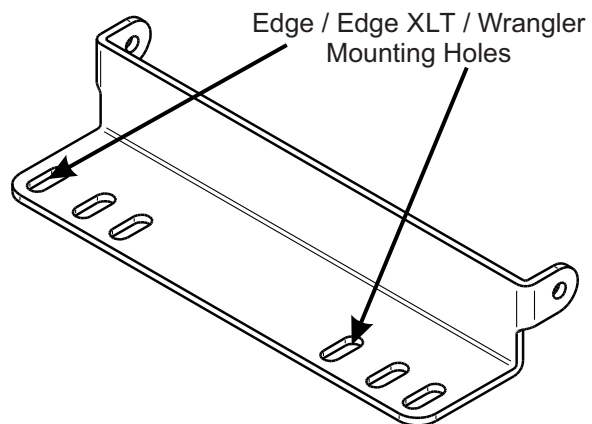

2-17 Length Of Hose Adjustment

The hoses in steps 2-18 and 2-19 must be cut to fit your machine. Follow steps 2-18 and 2-19. do not cut the hoses until you have tried to fit them on your machine. Remember that the hoses have to be long enough to adjust for the blower assembly's movement as well as allow for enough clamping surface between the inlet, blower assembly, and the deck boot.

2-18 Upper Hose Installation

Fasten the inlet to the plastic top by sliding the inlet from the inside of the top to the outside and lock into place. Slide a pre-assembled hose clamp P#(J0060) onto both ends of the 6" upper hose (Figure 2-20). Then slide one end of the 6" hose onto the inlet. Make sure there is about a two-inch overlap between the hose end and the container inlet. Proceed to slide the opposite end of the 6" hose onto the outlet of the blower assembly. See (Figure 2-20) for details. Make sure both ends of the hose are clearly attached to the inlet and the blower assembly inlet. Tighten the hose clamps.

2-19 Lower Hose To Blower Cone Installation

Slide a pre-assembled hose clamp P#(J0080) over both ends of the lower hose. Then proceed to slide the lower hose onto the blower cone. Tighten the hose clamp. The assembly should look like Figure 2-20.

2-20 Lower Hose To Boot Installation

Take the unattached end of the lower hose and slide it over the circular end of the boot. Use the lower hose clamp to secure the hose to the boot (Figure 2-20). Tip: Before securing clamp rotate hose counter-clockwise (away from yourself) approximately 1" to aid in retaining boot to mower deck.

Figure 2-20

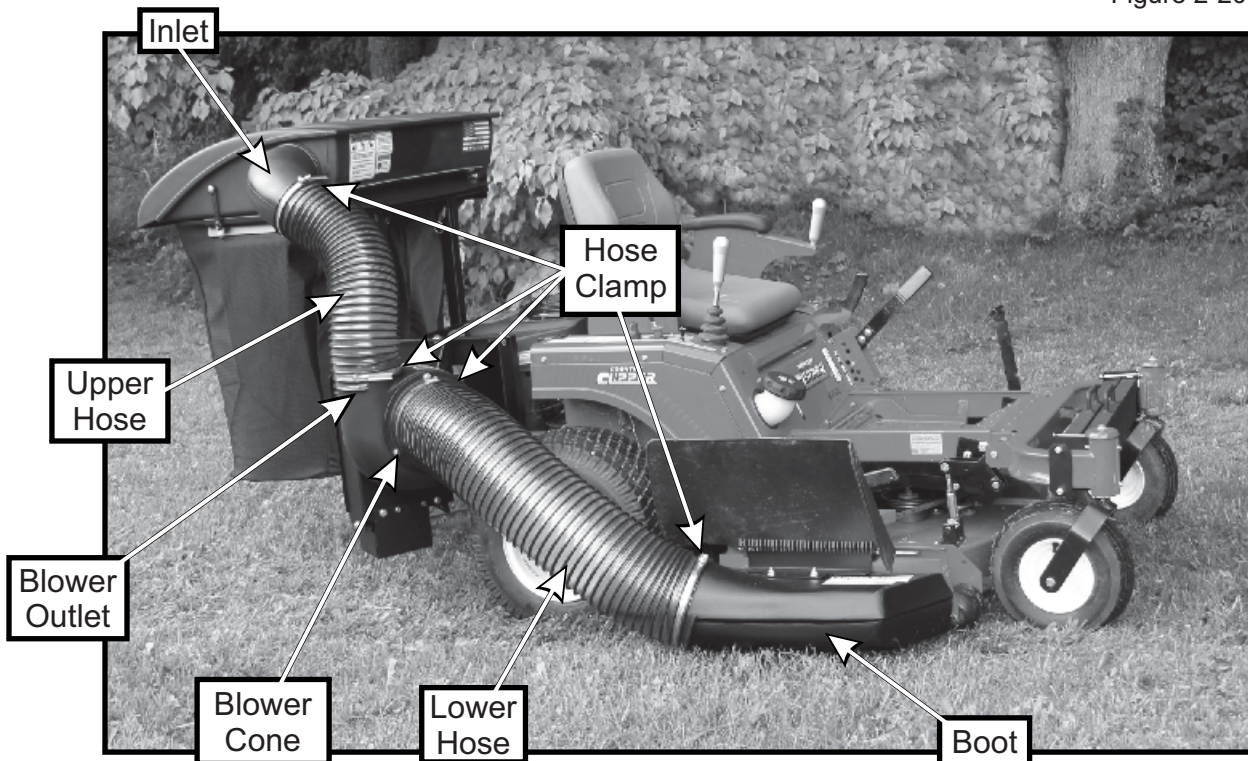

2-21 Impeller Blade Removal/Replacement



BEFORE REMOVING/REPLACING THE IMPELLER BLADES, BE SURE THE MOWER IS TURNED OFF, THE PTO ASSEMBLY IS DISENGAGED AND THE NEGATIVE CABLE IS REMOVED FROM THE BATTERY. FAILURE TO DO SO MAY RESULT IN SEVERE INJURY OR DEATH.

REMOVAL

STEP 1: Remove the blower cone P#(V0016) from the blower housing located on the PTO assembly P#(A1878). With the blower cone removed, you will have access to the impeller blade assembly P#(A1839). Refer to Figure 2-21.

STEP 2: Remove the 5/16"-24 LH x 1-1/4" hex bolt P#(K1171) and washer P#(K1446).

STEP 3: Insert the 1/2"-13 x 1" hex bolt (K1231) into the threads on the blade assembly and tighten. The blade should break free from the shaft.

STEP 4: Remove the blade assembly and key P#(J0254) from the PTO shaft. **Note:** If necessary, use a break free agent to aid in the removal of the blade.

INSTALLATION

STEP 1: Insert the key P#(J0254) into the key way on the PTO shaft.

STEP 2: Insert the blade assembly P#(A1839) onto the PTO shaft.

STEP 3: Secure the blade assembly to the PTO shaft with (1) washer P#(K1446) and (1) 5/16"-24 LH x 1-1/4" hex bolt. Torque the bolt to 19 ft./lbs.

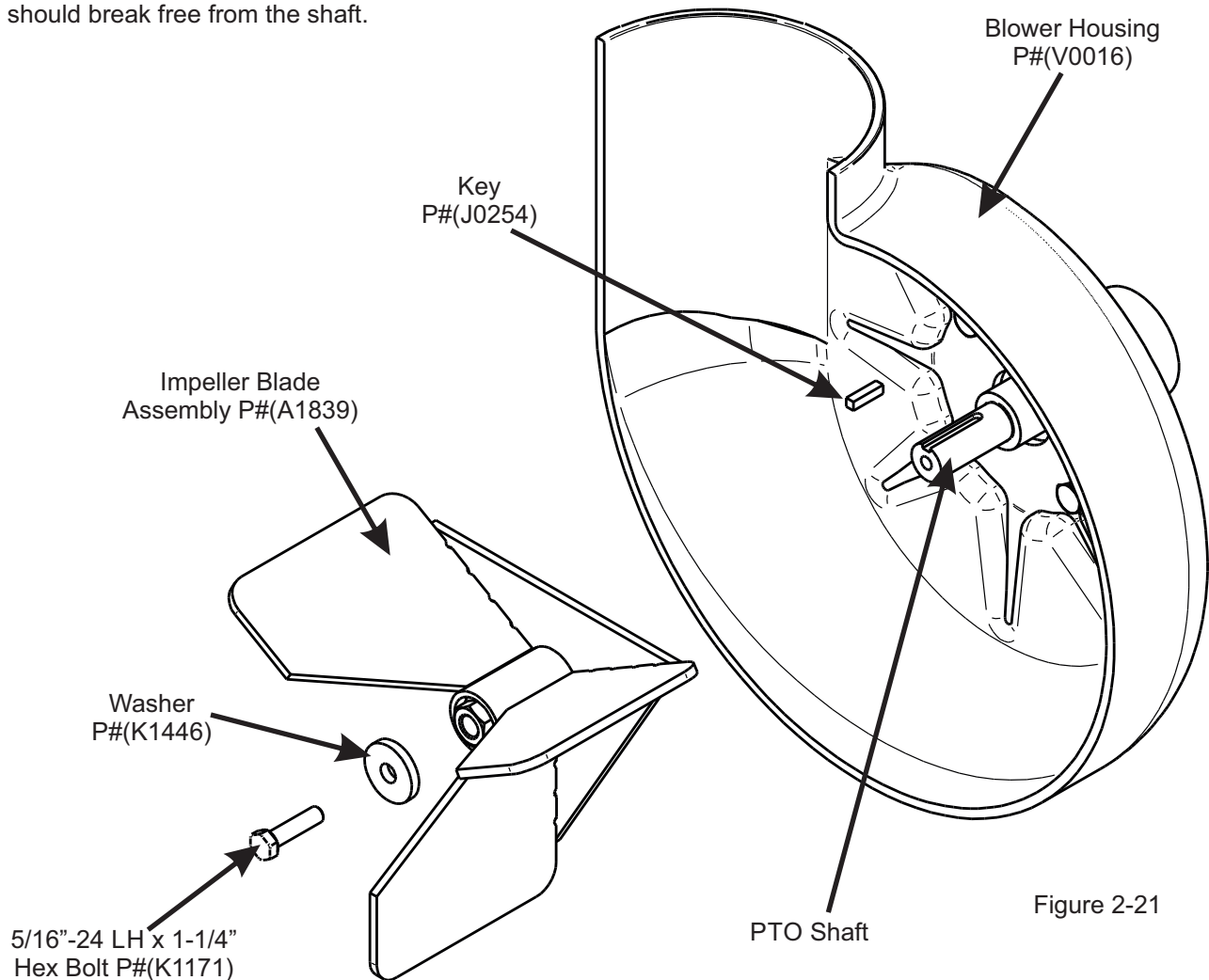

2-22 Weight Kit Installation

Edge XLT Series

A front counter weight must be installed to this unit before operation of the collection system. Remove the front step and hardware from the mower.

Attach (2) weight bracket clamps P#(B0834) and (2) weight brackets P#(B0479) to the front casters of the mower using (2) 3/8"-16 x 1" carriage bolts P#(K1182) and (2) 3/8"-16 nylon flange locknuts P#(K2038) PER BRACKET assembly. Insert (2) weight assemblies into the weight brackets and secure using (1) clevis pin P#(K1625) and (1) hair pin clip P#(K0086) PER BRACKET assembly. Refer to Figure 2-22a for reference.

Figure 2-22a

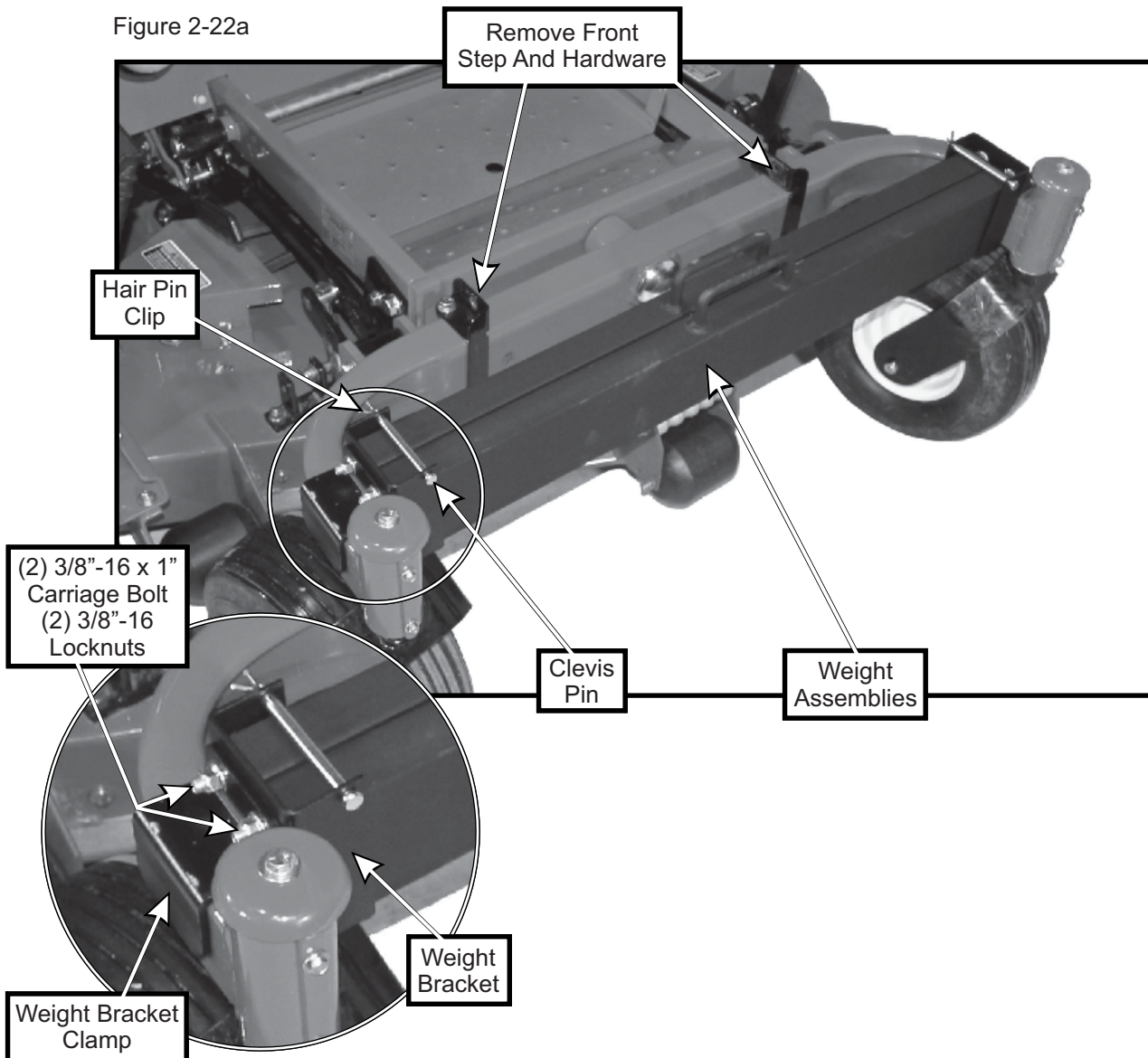

2-22 Weight Kit Installation Cont.

Edge & Wrangler Series

A front counter weight must be installed to this unit before operation of the collection system.

NOTE: If there is a front deck step installed on your mower, remove the front step and hardware.

Fasten the weight brackets P#(B0479) to the front casters using (2) 3/8"-16 x 3" HHCS P#(K1187) and (2) 3/8"-16 nylon flange locknuts P#(K2038) PER BRACKET). Leave the bolts finger tight until the weight assemblies P#(A1113) for the Wrangler or P#(A0852) Edge Series have been installed. Insert the weight assemblies into the weight brackets and secure using (1) clevis pin P#(K1625) and (1) hair pin clip P#(K0086) PER BRACKET. Tighten all hardware at this time. Refer to Figure 2-22b.

Figure 2-22b

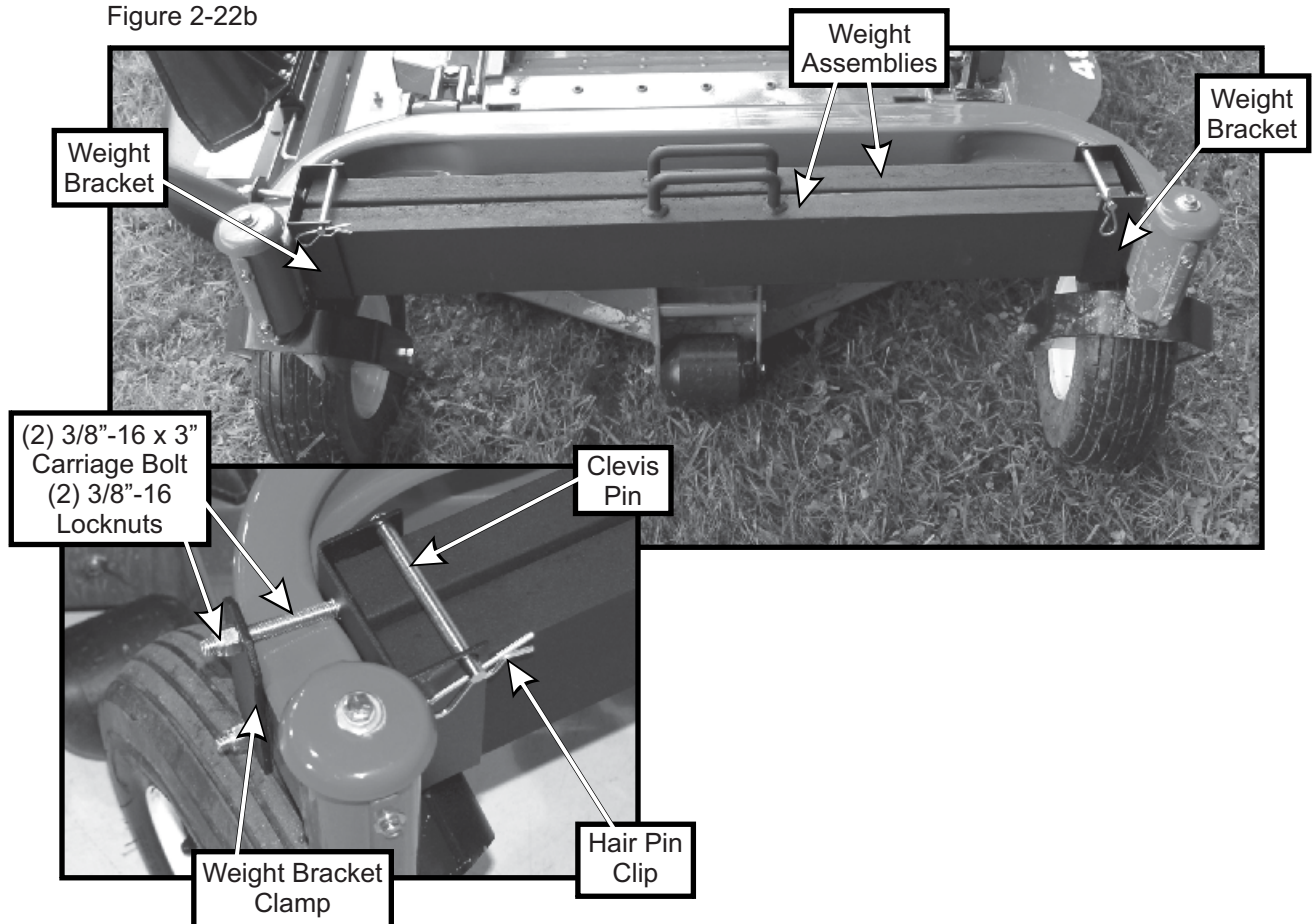

2-23 Installation/Removal Of Collection Bags

IMPORTANT!

To prevent bag wear, install (2) red plastic end caps P#(J0274), as shown in Figure 2-23a, on each bag ring before installing bags.

Figure 2-23a

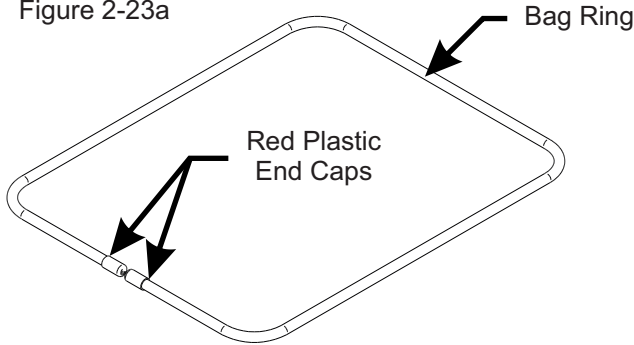

To install the bag onto the bag ring, place the seam openings of the bag onto the bag ring openings and turn the bag one full turn (360°) so the plastic end caps are located opposite to the opening in the bag (Figure 2-23b). Do this for each bag.

Figure 2-23b

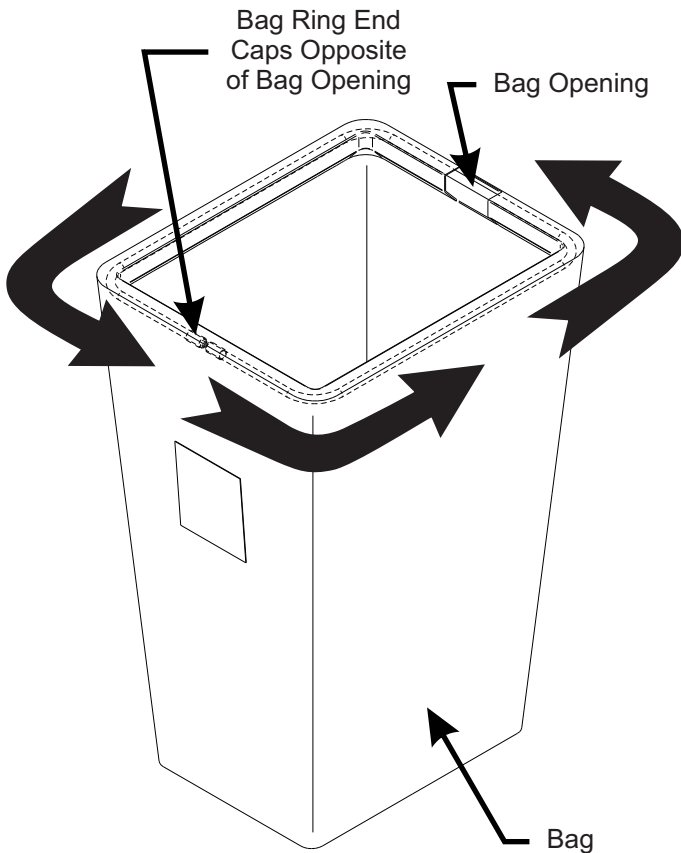

Install the completed assemblies onto the support frame and close the plastic top. Fasten the draw-latches to hold the plastic top closed (Figure 2-23c).

Figure 2-23c

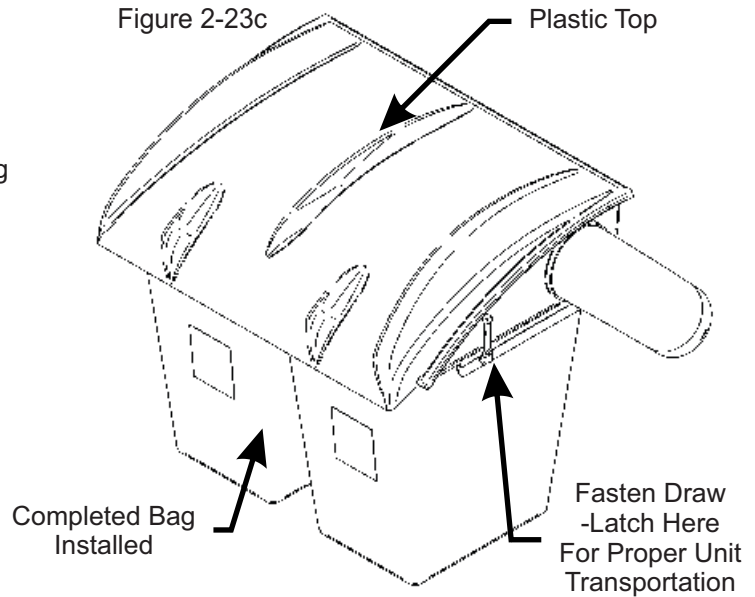

To empty the bag, first unlatch and lift top, next remove the bag and bag ring by sliding rearward, then grasp the loop on the bottom of the bag, and last turn it upside down to empty the collected debris (Figure 2-23d). Repeat for the other bag. Reinstall both bags, line with plastic bags if desired, close the plastic top and reattach the draw latches.

Figure 2-23d

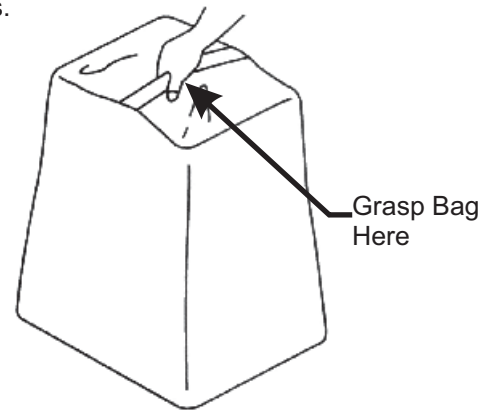

Plastic lawn and leaf bags, 33 gallon size, may be used inside the cloth bags. Be sure to leave enough plastic bag hanging over the frame so the plastic bags can be twist tied before emptying (Figure 2-23e).

Figure 2-23e

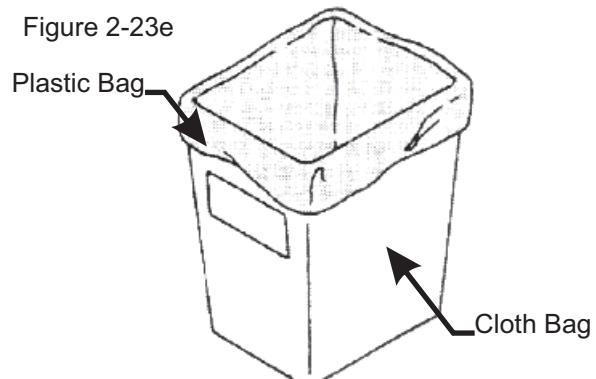

**A1938 TOP ASSEMBLY
A1114 UPPER FRAME ASSEMBLY
EXPLODED PARTS VIEW**

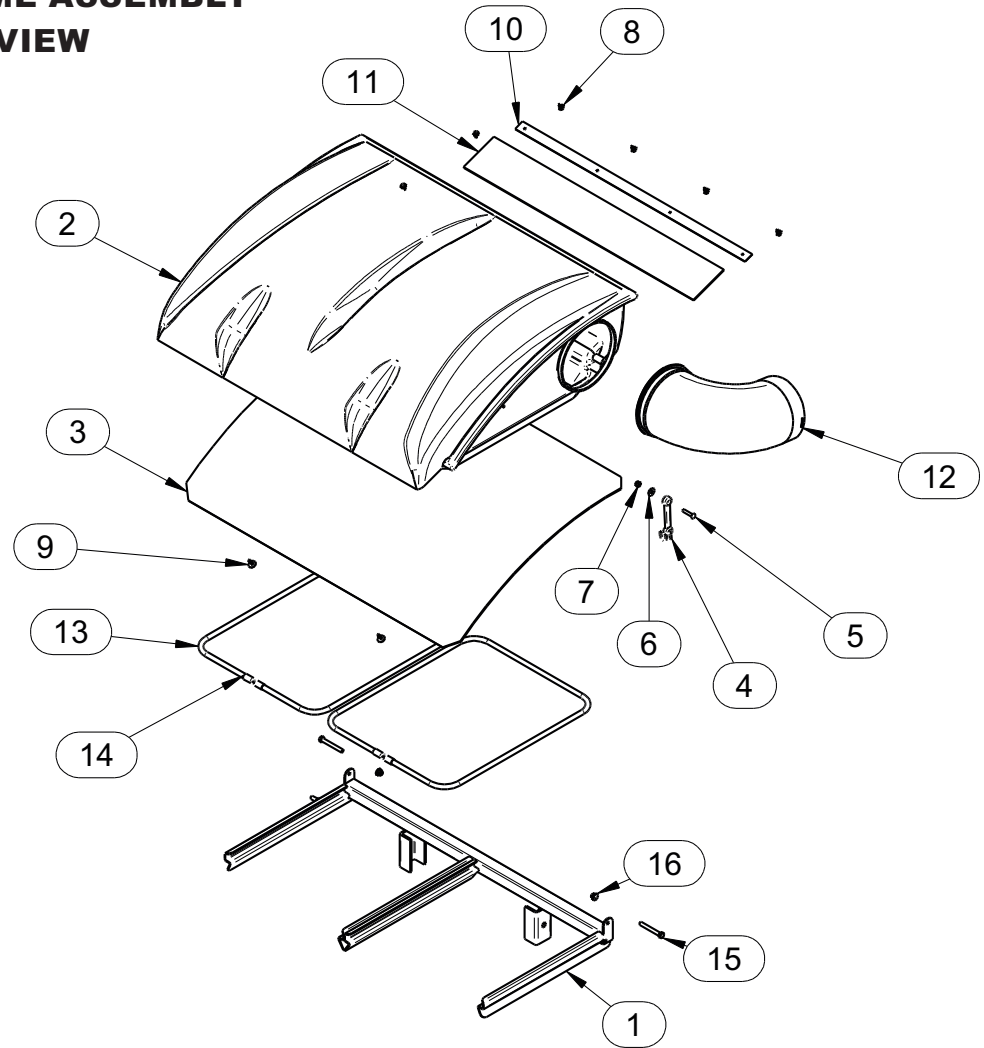

Item #	Part #	Desc.	Qty.
1	A1114	2 BAG FRAME ASSY	1
2	V0017	PRO 2 BAGGER TOP	1
3	V0018	Black Plastic Screen	1
4	J4009	SHORT RUBBER STRAP W/ S HOOK	1
5	K1030	1/4\"-20 x 1-1/4\" CARRIAGE BOLT	1
6	K0037	1/4\" FLAT WASHER .75 OD x .314 ID x .060 T	1
7	k1128	1/4\"-20 NYLOC NUT	1
8	K0114	BLACK PLASTIC RIVET	6
9	K1265	BLACK PANEL RETAINER	2
10	C0067	DUST GUARD BRACE	1
11	V1117	DUST GUARD	1
12	V0019	INLET	1
13	b0227	BAG RING	2
14	j0274	BAG RING END CAP	4
15	K0125	5/16\"-18 x 2-1/2\" ALL THREAD HHCS	2
16	K2516	5/16\"-18 Nylon Flange Locknut	2

A1840 PTO ASSEMBLY EXPLODED PARTS VIEW DESCRIPTION

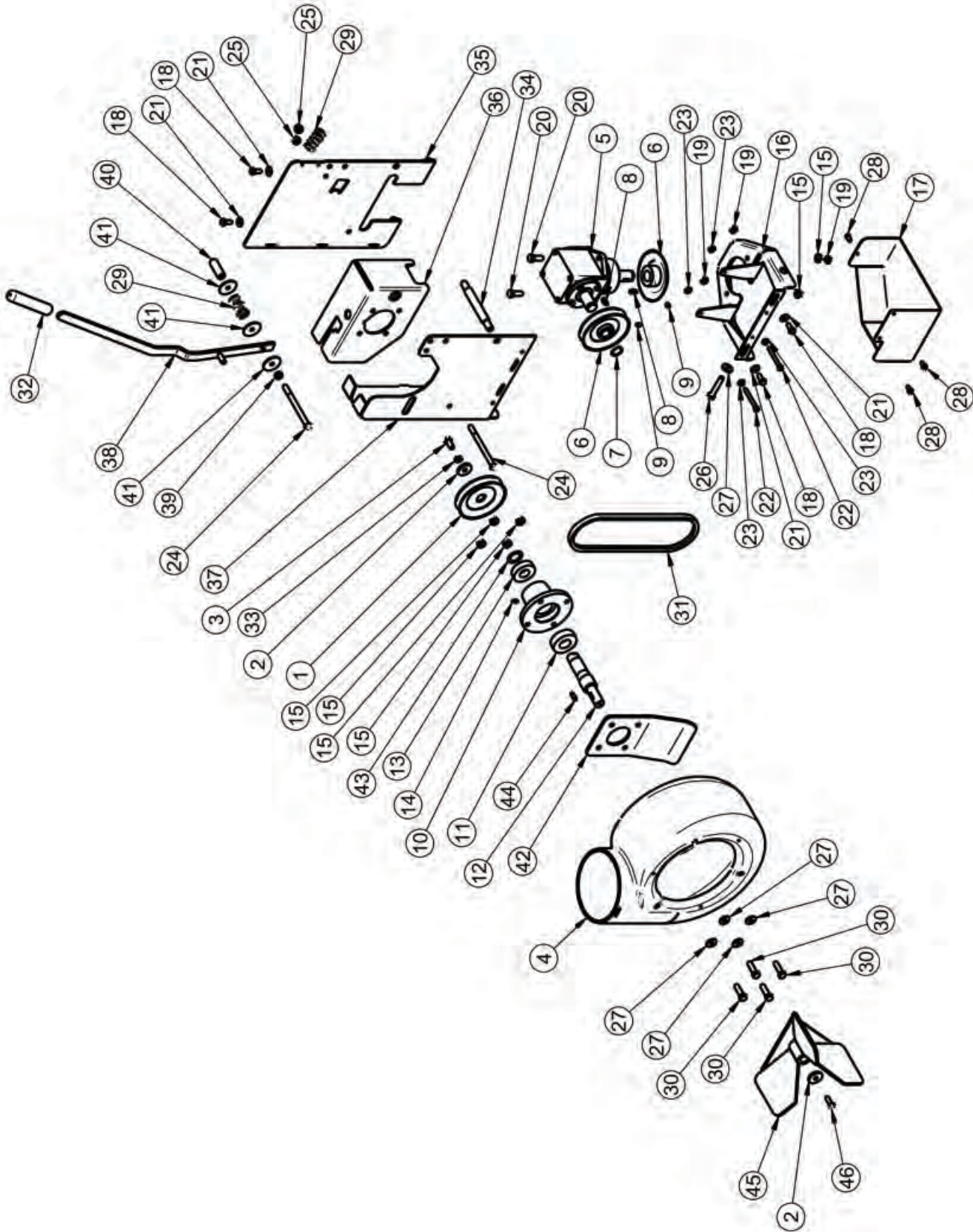

**A1840 PTO ASSEMBLY
EXPLODED PARTS VIEW**

Item #	Doc #	Title	Qty
1	M0266	'A' PULLEY FOR DECK DRIVE PTO	1
2	K1446	1.187 OD x .380 ID x .187 WASHER	2
3	k1190	3/8"-16 x 3/4" HHCS	1
4	V0015	BLOWER HSG.	1
5	A0431	GEAR BOX	1
6	A0498	PULLEY ASSY. FOR GEAR BOX	2
7	K0360	7/8" SNAP RING	2
8	J0272	#9 WOODRUFF KEY	2
9	K0035	5/16-18 SET SCREW	2
10	E0015	PTO SHAFT HOUSING	1
11	n0147	BEARING 2.0472 OD, 0.9843 ID, 0.5906 W (6205RS PEER)	1
12	B0460	PTO SHAFT	1
13	N0165	BEARING	1
14	J0801	1/4"-28 ZIRC FITTING	1
15	K1215	3/8"-16 FLANGE NUT	7
16	B0466	BASE PL.	1
17	B0478	GEAR BOX PULLEY GUARD	1
18	K1153	5/16"-18 x 3/4" HHCS	4
19	K1178	5/16"-18 FLANGE NUT	4
20	k1191	3/8"-16 x 1" HHCS	2
21	K0037	1/4" FLAT WASHER .75 OD x .314 ID x .060 T	4
22	k1150	1/4"-20 x 2-1/4" HHCS	2
23	K1126	1/4"-20 FLANGE NUT	4
24	K1202	3/8"-16 x 4-1/2" HHCS G5	2
25	k1216	3/8"-16 NYLOC NUT	2
26	K0348	3/8"-16 x 2" ALL THREAD HHCS	1
27	k0042	5/16" FLAT WASHER .875 OD x .380 ID x .075 T	5
28	K0353	1/4"-20 x 1/2" HHSTS	3
29	J0303	SPRING	2
30	K1192	3/8"-16 x 1-1/4" HHCS	4
31	M0267	A28K KEVLAR BELT	1
32	V1151	5/8" ID x 4-3/4" BLACK HANDLE GRIP	1
33	K0048	3/8" LOCK WASHER	1
34	B0505	PTO ARM MNT. ROD	1
35	B0506	LT. PTO ARM	1
36	B0642	BLWR. MNT. BRKT.	1
37	B0643	RT PTO ARM	1
38	A1112	PTO HANDLE ASSY	1
39	B0510	SPACER BUSHING	1
40	B0511	SPACER BUSHING	1
41	K0403	WASHER 1-1/2" OD x 3/8" ID	3
42	B0739	Blower Hsg. Stiffener Pl.	1
43	K0070	Flat Washer SS	1
44	J0254	3/16" x 3/16". x 3/4" Key	1
45	A1839	3-Blade Impeller Assy.	1
46	K1171	5/16"-24 LH x 7/8" HHCS GR. 5 w/ Patch Coating	1



Unit Model #: 49120901 (629GM-001A)

Mower: Country Clipper

Owner's Manual: Q0468

Mower Type: Edge & Edge XLT

Engine Type: KW FR730V & FS651V - KH 27HP

Deck Size: 48" & 52"

Vac Type:

Deck Type:

Drive Type: PTO (3-Blade)

Revision #: 2.2 - Updated Model Year - 9/6/2017

Fits Year(s): 2013 - 2017

Vac Kit A1935

- (2) J0080 8" Hose Clamps
- (2) J0060 6" Hose Clamps
- (1) A1938 Top Assy.
- (1) V0019 INLET
- (1) B0809 Left Frame Bracket
- (1) B0810 Rt. Frame Bracket
- (1) B0808 Rear Mount Plate
- (2) B0752 Lwr. Mnt. Tube
- (1) F0060 6" x 28" Upper Hose
- (1) F0080 8" x 40" Lower Hose
- (2) B0227 Bag Ring
- (2) G0003 4 Cu. Ft. Collection Bags
- (1) HB0572 Vac Kit Hardware Bag

Mount Kit A1937

- (1) B0811 Lt. PTO Mnt. Pl.
- (1) B0812 Rt. PTO Mnt. Pl.
- (1) HB0569 Engine Pulley Hardware Bag
- (1) B0818 Rear Frame Mnt. Bracket
- (1) B0817 Rear Frame Mnt. Bracket
- (1) B0733 PTO Stop Plate
- (1) E8004 8" Blower Cone
- (1) A1840 3-Blade PTO Assembly
- (1) HB0571 Mount Kit Hardware Bag

A1948 Boot Kit

- (1) B0841 Blow-By Bracket
- (1) B0820 Boot Plate
- (1) HB0581 Hardware Bag
- (1) B4331 Boot Rod
- (1) E1902A Boot

A1939 Weight Kit

- (1 LT. & 1 RT.) B0479 Weight Brkt.
- (2) B0834 Weight Brkt. Clamp
- (2) B0419 Weight Mnt. Pl.
- (2) A0852 Weight Assy.
- (1) HB0582 Hardware Bag



Unit Model #: 49120902 (629GL-001A)

Mower: Country Clipper	Owner's Manual: Q0468
Mower Type: Wrangler	Engine Type: Kawasaki FS651V & Kohler 22HP
Deck Size: 41", 48" & 52"	Vac Type:
Deck Type:	Drive Type: PTO (3-Blade)
Revision #: 2.1 - Updated Model Year - 9/6/2017	Fits Year(s): 2013 - 2017

Vac Kit A1935

- (4) J1000 Hose Clamps
- (1) A1938 Top Assy.
- (1) V0019 INLET
- (1) A1114 UPPER FRAME ASSY
- (2) B0227 Bag Ring
- (1) B0809 Left Frame Bracket
- (1) B0810 Rt. Frame Bracket
- (1) B0808 Rear Mount Plate
- (2) B0752 Lwr. Mnt. Tube
- (1) F0060 6" x 28" Upper Hose
- (1) F0080 8" x 40" Lower Hose
- (2) G0003 4 Cu. Ft. Collection Bags

Mount Kit A1965

- (1) B0811 Lt. PTO Mnt. Pl.
- (1) B0812 Rt. PTO Mnt. Pl.
- (1) B0818 Rear Frame Mnt. Bracket
- (1) B0817 Rear Frame Mnt. Bracket
- (1) B0733 PTO Stop Plate
- (1) E8004 8" Blower Cone
- (1) HB0569 Engine Pulley Hardware Bag
- (1) A1840 3-Blade PTO Assembly

A1948 Boot Kit

- (1) B0841 Blow-By Bracket
- (1) B4331 Boot Rod
- (1) B0820 Boot Plate
- (1) HB0581 Hardware Bag
- (1) E1902A Boot

A1129 Weight Kit

- (2) A1113 Weight Assy.
- (1 LT. & 1 RT.) B0479 Weight Brkt.
- (2) B0419 Weight Mnt. Pl.
- (1) HB0353 Hardware Bag

SECTION III - P2B+

OPERATING INSTRUCTIONS

3-1 General Safety

Only qualified people familiar with this operator's manual and the mower's operator's manual should operate this machine.

3-2 Operation And Tips On Mowing

- A. Perform BEFORE EACH USE the maintenance list in paragraph 4-1.
- B. Start mower.
- C. With the mower at high idle speed, engage the mower deck.
- D. While seated in the operator's seat, pull the engagement handle of the PTO assembly towards the operator's seat until the handle slides into position in the retaining slot. With the PTO assembly engaged, you can proceed to operate the control levers of the mower.

NOTE: If the collection system does not appear to be collecting the grass clippings, disengage the deck and PTO assembly, then, engage the parking brake and turn the mower off. Proceed to section 3-3, and review the sections regarding PTO assembly Installation and belt installation/removal and adjustment. Check upper and lower hoses for any clogs.

To obtain the maximum effectiveness from your collection system, the tips listed below should be followed:

- * Watch your speed- Normal conditions will allow a speed of up to approximately 4 mph, but thick, heavy damp conditions will require reduced ground speed.
- * Mow with sharp blades- A sharp blade cuts cleaner.
- * Wet grass and leaves will decrease effectiveness and will increase horsepower requirements.
- * Mow at higher cutting heights- Remove and mulch no more than 2" of grass length with each mowing. (Experts recommend not cutting off more than 1/3 of the grass blade length at any given time.)
- * Mow twice, at different height settings, (high, then low), if grass is extra tall.
- * Remember that horsepower requirements will vary with the mowing conditions such as type and height of turf grass, moisture content, amount of leaves, whether the terrain is flat or hilly, etc.

3-3 Disengagement Of The PTO Assy.

- A. To disengage the PTO assembly, slide the engagement handle out of the retaining slot and push the engagement handle away from the operator's seat.

WARNING: The PTO assembly blades will continue to spin. DO NOT TOUCH the PTO assembly, pulleys, or the belt until the tractor is turned off. DO NOT adjust the belt tension until the mower is turned off. Refer to the belt adjustment section of the manual.

3-4 Unloading The Collection System

NOTE: To determine when the collection bags are full, follow the following steps:

- A. Stop the forward movement of the mower.
- B. Disengage the mower deck.
- C. Disengage the PTO assembly.
- D. Engage the parking brake.
- E. Once the parking brake has been engaged, then and only then, walk behind the mower and check the collection bags by first unhooking the rubber strap with S-hook that secures the plastic top, then lift the plastic hood. Load in bags should not exceed the height of the installed bag.
- F. To remove the bags from the frame slide bags out and turn bags over to deposit clippings.
- G. Slide empty bags back onto the frame and secure plastic top with the rubber strap with S-hook.

NOTE: Do not allow collection bags to become over-filled as potential damage may occur to your equipment. Also, be sure to clean the hood screen as needed.

SECTION I - MAINTENANCE

4-1 Maintenance Checklist

NOTE: REMOVE PTO ASSEMBLY BEFORE RAISING DECK FOR MAINTENANCE.

Before each use:

1. Check blades and spindles to be sure that no foreign objects, such as wire or steel strapping bands, are wrapped around them.
2. Inspect blades for wear. Replace if necessary. If it is necessary to sharpen the blades, remove the blades from the spindles before sharpening. DO NOT sharpen blades while still attached to the mower.

3. Make sure all shields are in place and in good condition. Repair or replace any missing or damaged shields.
4. Perform lubrication per paragraph 4-2.
5. Listen for abnormal sounds, which might indicate loose parts, damaged bearings, or other damage. Correct any deficiency before continuing operation.
6. With the engine off, engage the blower assembly. Check the belt tension and inspect the pulley belt for cracks or tears.
7. Check for wear or deterioration of the upper or lower hoses. If there are any portions of the hose that have been torn or worn through, replace immediately.

After Each Use:

1. Clean all debris from machine especially from the container, underneath the belt shields, and safety decals. Replace any missing or illegible decals.
2. Inspect the unit for worn or damaged components. Repair or replace before the next use. Any replacement component installed during repair shall include the component's current safety decal specified by the manufacturers to be affixed to the component.
3. Under normal usage, the bag material is subject to deterioration and wear and should therefore be frequently checked for necessary replacement. Any replacement bag should be checked to ensure compliance with the original manufacturer's recommendations or specifications.
4. Check belt for proper tension.

4-2 Lubrication

Gearbox:

1. Every 20 hours of use: Check oil levels in gearbox.
2. First 60 hours of use: Change oil.
3. Every 100 hours of use: Change oil.

NOTE: Oil in gearbox should cover the gears. If not, drain the gearbox and fill using an 80W-90 gear oil. The gearbox ships with 6.0 oz. of oil, but we recommend replacing with a measured 5.5 oz. to fill the gearbox. **DO NOT OVERFILL!**

Blower Assembly:

NOTE: The following is for older PTO models that contain a greaseable zirc fitting. Newer models contain maintenance-free bearings and are without a greasable fitting.

1. On initial use: Grease the fitting on the blower shaft.
2. Every 25 hours of use: Re-grease the grease fitting.

NOTE: Use only white lithium based grease for lubrication of the shaft on the blower assembly.

SECTION V - PARTS & SERVICE

5-1 Parts And Service Information

Collection system owners should record the name and telephone number of their Service Center. Your Service Center will be happy to supply replacement parts, accessories, and do any service or repairs to your collection system. If for any reason your Service Center is unable to service your collection system or supply replacement parts, contact Country Clipper and include the following information on the chart below.

DOCUMENT THE FOLLOWING INFORMATION FOR FUTURE REFERENCE

Unit Model Number: _____

Unit Engine Size: _____

Unit Serial Number: _____

Date of purchase: ____ / ____ / ____

Dealer/Distributor Name: _____

Address: _____ **State:** _____ **Zip:** _____

Phone Number: _____

Country Clipper Division of Shivers Mfg. Inc
613 W. English | Corydon, IA | 50060
Phone: 1-800-344-8237 | 641-872-2544
Fax: 641-872-1593
E-Mail: countryclipper@countryclipper.com

SAFETY DECALS

To promote safe operation, Country Clipper supplies safety decals on all products manufactured. Damage can occur to safety decals either through shipment, use or reconditioning. Contact your local Service Center for replacement decals.



Part #: R4037
Warning: Hot Surface Label



Part #: R2008
Rotating Blades Label



Part #: R1051
Warning: Hearing Protection Label



Part #: R2007
Never Use Hands Label

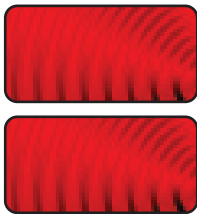

Part #: R1057 - (2)



Part #: R1065
Made In America Label



Part #: R1069
Warning: Turn Off Blower Label



Part #: R1100
Engage-Disengage Label

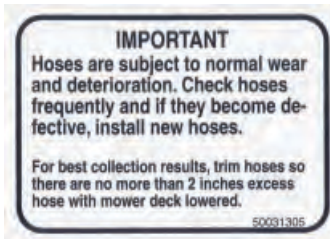

Part #: R1054
Important Label



Part #: R4015
Danger: Rotating Blades Label



Part #: R4008
Caution: Rotating Blades Label



Part #: R1052
Small Warning: Turn Off Blower Label

TORQUE SPECIFICATIONS

AMERICAN Bolt Head Markings

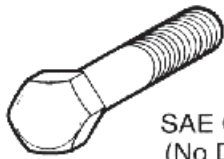

SAE Grade 2
(No Dashes)

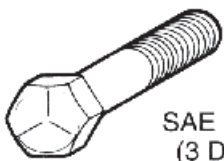

SAE Grade 5
(3 Dashes)

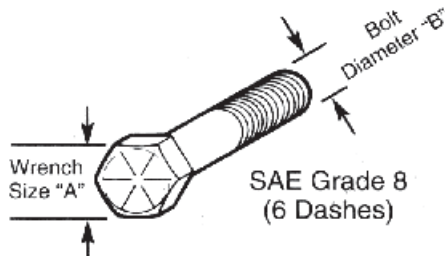

SAE Grade 8
(6 Dashes)

Recommended Torque in Foot Pounds (Newton Meters).*

WRENCH SIZE (IN.) "A"	BOLT DIAMETER (IN.) "B" AND THREAD SIZE	SAE GRADE 2	SAE GRADE 5	SAE GRADE 8
7/16	1/4 - 20 UNC	6 (7)	8 (11)	12 (16)
7/16	1/4 - 28 UNF	6 (8)	10 (13)	14 (18)
1/2	5/16 - 18 UNC	11 (15)	17 (23)	25 (33)
1/2	5/16 - 24 UNF	13 (17)	19 (26)	27 (37)
9/16	3/8 - 16 UNC	20 (27)	31 (42)	44 (60)
9/16	3/8 - 24 UNF	23 (31)	35 (47)	49 (66)
5/8	7/16 - 14 UNC	32 (43)	49 (66)	70 (95)
5/8	7/16 - 20 UNF	36 (49)	55 (75)	78 (106)
3/4	1/2 - 13 UNC	49 (66)	76 (103)	106 (144)
3/4	1/2 - 20 UNF	55 (75)	85 (115)	120 (163)
7/8	9/16 - 12 UNC	70 (95)	109 (148)	153 (207)
7/8	9/16 - 18 UNF	79 (107)	122 (165)	172 (233)
15/16	5/8 - 11 UNC	97 (131)	150 (203)	212 (287)
15/16	5/8 - 18 UNF	110 (149)	170 (230)	240 (325)
1-1/8	3/4 - 10 UNC	144 (195)	266 (360)	376 (509)
1-1/8	3/4 - 16 UNF	192 (260)	297 (402)	420 (569)
1-5/16	7/8 - 9 UNC	166 (225)	430 (583)	606 (821)
1-5/16	7/8 - 14 UNF	184 (249)	474 (642)	668 (905)
1-1/2	1 - 8 UNC	250 (339)	644 (873)	909 (1232)
1-1/2	1 - 12 UNF	274 (371)	705 (955)	995 (1348)
1-1/2	1 - 14 UNF	280 (379)	721 (977)	1019 (1381)
1-11/16	1-1/8 - 7 UNC	354 (480)	795 (1077)	1288(1745)
1-11/16	1-1/8 - 12 UNF	397 (538)	890 (1206)	1444 (1957)
1-7/8	1-1/4 - 7 UNC	500 (678)	1120 (1518)	1817 (2462)
1-7/8	1-1/4 - 12 UNF	553 (749)	1241 (1682)	2013 (2728)
2-1/16	1-3/8 - 6 UNC	655 (887)	1470 (1992)	2382 (3228)
2-1/16	1-3/8 - 12 UNF	746 (1011)	1672 (2266)	2712 (3675)
2-1/4	1-1/2 - 6 UNC	870 (1179)	1950 (2642)	3161 (4283)
2-1/4	1-1/2 - 12 UNF	979 (1327)	2194 (2973)	3557 (4820)

METRIC

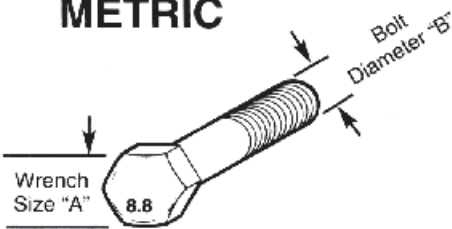

Numbers appearing on bolt heads indicate ASTM class.

Recommended torque in foot pounds (newton Meters).*

WRENCH SIZE (mm) "A"	BOLT DIA. (mm) "B"	ASTM 4.6	ASTM 8.8	ASTM 9.8	ASTM 10.9
8	5	1.8 (2.4)		5.1 (6.9)	6.5 (8.8)
10	6	3 (4)		8.7 (12)	11.1 (15)
13	8	7.3 (10)		21.1 (29)	27 (37)
16	10	14.5 (20)		42 (57)	53 (72)
18	12	25 (34)	74 (100)	73 (99)	93 (126)
21	14	40 (54)	118 (160)	116 (157)	148 (201)
24	16	62 (84)	167 (226)	181 (245)	230 (312)
30	20	122 (165)	325 (440)		449 (608)
33	22		443 (600)		611 (828)
36	24	211 (286)	563 (763)		778 (1054)
41	27		821 (1112)		1138 (1542)
46	30	418 (566)	1119 (1516)		1547 (2096)

*Use 75% of the specified torque value for plated fasteners. Use 85% of the specified torque values for lubricated fasteners.

Notes

C O U N T R Y
CLIPPER
ZERO TURN MOWER

Country Clipper Division of Shivers Mfg. Inc

613 W. English | Corydon, IA | 50060

Phone: 1-800-344-8237 | 641-872-2544

Fax: 641-872-1593

E-Mail: countryclipper@countryclipper.com