

Cub Cadet®

PRO-X

DESIGNED
TO FIT:

POWER ASSIST DFS 12 Cu. Ft.

MODEL YEAR:

2016-NEWER

Series:

PRO Z 500, 700, 900 L&S 54" & 60" DECKS

COLLECTION SYSTEM

MODEL # 59A30051150

ALTERNATE

MODEL # 21651217



* **L MODELS:** COLLECTION SYSTEM REQUIRES INSTALLATION
OF ADDED WEIGHT KIT P# 59B30037150 (A1149) FOR SAFE OPERATION!

OPERATOR'S MANUAL

ASSEMBLY • OPERATION • MAINTENANCE

GRASS COLLECTION SYSTEM

TABLE OF CONTENTS

SECTION	PAGE	SECTION	PAGE
Safety	2	2-14 Upper Hose Installation	16
Safety Alert Symbols	3	2-15 Lower Hose To Blower Cone Installation	16
Warranty	4	2-16 Lower Hose To Boot Installation	16
I INTRODUCTION AND DESCRIPTION	5	2-17 Safety Interlock Harness Installation	17-19
1-1 Introduction	5	2-18 Impeller Blade Removal/Replacement	20
1-2 Description	5	Weight Kit Installation Instructions	21
II INSTALLATION FOR USE	5	Exploded Views & Parts List	22-32
2-1 Preparation Of Mower	5	Pack Drawing	33
2-2 Mount Arm Preparation and Installation	6	Safety Decals	34
2-3 PTO Drive Assembly	7-8	III OPERATING INSTRUCTIONS	35
2-4 Drive Assembly and Belt Installation	9	3-1 General Safety	35
2-5 Lower Main Frame Leg Installation	10	3-2 Operation & Tips On Mowing	35
2-6 Main Frame Assembly Installation	10	3-3 Disengagement Of The PTO Assembly	35
2-7 Lift Handle Installation	11	3-4 Unloading The Collection System	35
2-8 Aluminum Box Assembly Installation	12	IV MAINTENANCE	35-36
2-9 Dump Mechanism Adjustment	12	4-1 Maintenance Checklist	35
2-10 Inlet, Inlet Ring & Debris Deflector Installation	13	4-2 Lubrication	36
2-11 Blower Cone Installation	14	V PARTS AND SERVICE	36
2-12 Boot To Mower Deck Installation	15	5-1 Parts And Service Information	36
2-13 Length of Hose Adjustment	16	Torque Specifications	37
		Troubleshooting	38
		Notes	39

SAFETY

1. Read the operator's manual carefully and familiarize yourself with the proper use of your attachment. Do not allow anyone who is not acquainted with the Safety Instructions to use your attachment.
2. Know the controls and how to stop them quickly. **READ THE OPERATOR'S MANUAL!**
3. Do not allow children to operate the machine. Do not allow adults to operate it without proper instruction.
4. Be especially watchful of children and pets entering into the area while operating.
5. Keep your eyes and mind on your machine while mowing or operating your attachment. Don't let others distract you.
6. Do not attempt to operate your machine when not in the driver's seat.
7. Always shut off blades and engine when emptying the container.
8. Stop machine, shut off deck attachment, set parking brake, shut off engine and remove ignition key before removing clogs, removing or replacing hose, boot, blower cone, or performing any maintenance.
9. Mow across the face of slopes (not more than 10 degrees); never up and down the face.
10. It is recommended that the container be emptied when half full while operating on slopes. Start mowing on slopes when the container is empty.
11. Inspect your lawn and remove any foreign objects before mowing. Never deliberately run the mower across any foreign object.
12. Wear hearing protection.
13. Wear eye protection to prevent debris from getting into your eyes.

SAFETY

WARNING! NEVER operate the mower unless the discharge guard and either the deflector assembly or the vacuum collector adapter are fastened securely in place.

WARNING! Do not work around the mower deck boot or the blower area until you are certain that the mower blades and the blower impeller have stopped rotating.

WARNING! To avoid serious injury, perform maintenance on the vacuum collector; **ONLY AFTER STOPPING THE MOWER'S ENGINE AND WAITING FOR ALL MOVING PARTS TO COME TO A COMPLETE STOP.** Set the parking brake. Always remove the ignition key before beginning maintenance.

WARNING! For your own personal safety, **ALWAYS mow ACROSS the face of slopes and NEVER UP and DOWN the face. NEVER attempt to mow excessively steep slopes, and use caution when turning on any slope.**

Safety Alert Symbol



This Safety Alert Symbol means: **“ATTENTION! BECOME ALERT! YOUR SAFETY IS INVOLVED!”**

This symbol is used to call attention to safety precautions that should be followed by the operator to avoid accidents. When you see this symbol, carefully read the message that follows and heed its advice. Failure to comply with safety precautions could result in death or serious bodily injury.

Safety Signs

The signal words **DANGER**, **WARNING**, and **CAUTION** are used on the equipment safety signs. These words are intended to alert the viewer to the existence and the degree of hazard seriousness.



White letters on **RED**

This signal word indicates a potentially hazardous situation which, if not avoided, will result in death or serious injury.



Black letters on **ORANGE**

This signal word indicates a potentially hazardous situation which, if not avoided, could result in death or serious injury.

It may also be used to alert against unsafe practices.



Black letters on **YELLOW**

This signal word indicates a potentially hazardous situation exist which, if not avoided, will result in minor or moderate injury.

It may also be used to alert against unsafe practices.

PECO LIMITED WARRANTY FOR NEW PRODUCTS

A. WHAT IS UNDER WARRANTY?

PECO extends the following warranties to the original purchaser of each new PECO consumer product subject to the following limitations.

- 1. PRODUCT WARRANTY:** Any part of any consumer product, which is defective in material or workmanship as delivered to the purchaser will be repaired or replaced, as PECO elects, without charge for parts or labor, if the defect appears within 12 months from the date of delivery of the product to the original purchaser. ALL DEFECTIVE PARTS MUST BE RETURNED TO PECO FOR INSPECTION TO DETERMINE VALIDITY OF WARRANTY CLAIMS. Freight and mailing will be borne by the customer.
- 2. PARTS REPLACED DURING WARRANTY:** Any new PECO part which is furnished in performance of this warranty and is defective in material or workmanship as delivered to the purchaser will be repaired or replaced, before the expiration of the original warranty period, whichever is later.
- 3. COMMERCIAL USE:** Products put to personal use around a single household or residence is considered 'Residential'; Products put to any business use (agricultural, commercial, or industrial) or used at multiple locations is considered 'Commercial.' Products designated as 'Commercial' are warrantied for 12 months from the date of delivery of the product to the original purchaser when used for in commercial applications. Products designated as 'Residential' are warrantied for 90 days from the date of delivery of the product to the original purchaser when in commercial applications.

B. SECURING WARRANTY ADJUSTMENTS

Call PECO for Return Authorization. Damaged or broken parts other than engines or batteries, must be returned to New PECO, Inc. at 10 Walden Drive, Arden, NC 28704 before any warranty adjustment can be authorized. At the time of requesting warranty adjustment, the purchaser must present evidence of the date of delivery of the product. The purchaser shall pay any charge for the product to and from Arden, NC.

C. ITEMS NOT COVERED BY PECO WARRANTY

Engines and batteries attached to PECO products are covered under a separate warranty by the respective manufacturer.

D. UNAPPROVED ALTERATION OR MODIFICATION

All obligations of New PECO, Inc. under this warranty shall be terminated if products are altered or modified in ways not approved by New PECO, Inc.

E. ACCIDENTS AND NORMAL MAINTENANCE

The warranty covers only defective material and workmanship. It does not cover depreciation or damage caused by normal wear, accident, improper use or abuse of products. The cost of normal maintenance and normal replacement of service items such as belts, cutting blades, hoses, etc., which are not defective shall be paid for by the purchaser.

F. NO REPRESENTATIONS ADDITIONAL WARRANTIES, DISCLAIMER

Neither New PECO, Inc. nor any company affiliated with it makes any warranties, representations or promises as to the quality of performance of its products other than those set forth herein. Except as described above, New PECO, Inc. makes no other warranties AND SPECIFICALLY DISCLAIMS ANY AND ALL IMPLIED WARRANTIES OF FITNESS AND MERCHANTABILITY.

G. PRODUCTS USED FOR RENTAL OR LEASE PURPOSES ARE WARRANTIED FOR 45 DAYS FROM DATE OF ORIGINAL SALE ONLY

H. REMEDIED EXCLUSIVE

The only remedies the purchaser has in connection with the breach or performance of any warranty on New PECO, Inc. consumer products are set forth above. In no event will PECO be liable for special incidental or consequential damages.

1. NO SERVICE CENTER WARRANTY

The selling Service Center makes no warranty on his own on any item warrantied by New PECO, Inc. unless he delivers to purchaser a separate written warranty certificate specifically warranting the item. The dealer has no authority to make any representation or promise on behalf of PECO or to modify the terms of this warranty in any way.

Section I - INTRODUCTION & DESCRIPTION

1-1 Introduction

Your grass collection system has been designed to give you a low maintenance, simple, and effective way to collect the grass clippings from your mower. This manual is provided to give you the necessary instructions to properly mount and operate the collection system on your mower. Please read this manual thoroughly. Understand what each control is for and how to use it. Observe all safety decal precautions on the machine and noted throughout the manual.

NOTE: All references made to right, left, front, rear, top or bottom are as viewed from the normal operator's position on the mower.

1-2 Description

The grass collection system is designed for turf maintenance where there is a need to collect the grass clippings as the mower cuts the turf. It is also used for picking up leaves and in pre-season and post-season clean-up. The blower, mounted on the right side of the unit, uses a belt and gearbox system from the engine PTO shaft. Drive train protection comes through belt slippage. The blower draws grass clippings from the discharge area of the cutter deck back to the 12 cubic foot aluminum box at the rear portion of the mower frame. The operator can engage the blower with a toggle switch mounted on the control panel to the right of the operator. Once the collection box is full with clippings, it can be released to make for easy dumping.

Section II - INSTALLATION FOR USE

L Models: Collection system requires installation of added weight kit 59B30037150 (A1149) for safe operation! **S Models** do not require a weight kit.

Collection System May Require Dealer Installation!

Please refer to Page 17 for further details.

Figure 2-1a

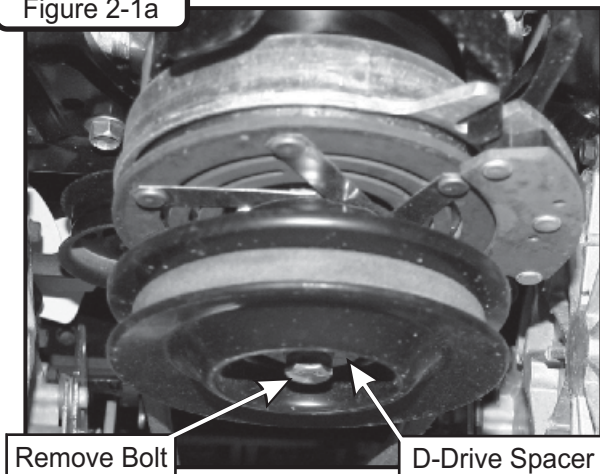

2-1 Preparation Of Mower

From the underside of the engine, disconnect the wiring harness attached to the electric clutch. Remove the bolt and electric clutch from the mower. Refer to Figure 2-1a. Remove the D-drive spacer using an arbor press or equivalent. On removal, adjacent bearing OUTER race must be supported or bearing damage may occur. Refer to Figure 2-1b.

Figure 2-1b

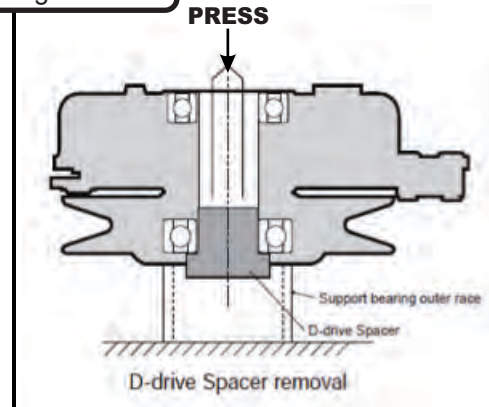

The Engine Pulley Bushing #18 P#(S0210) may need to be installed using an arbor press or equivalent. If pressed, opposite bearing inner race must be supported or bearing damage may occur. Refer to Figure 2-1c.

Figure 2-1c

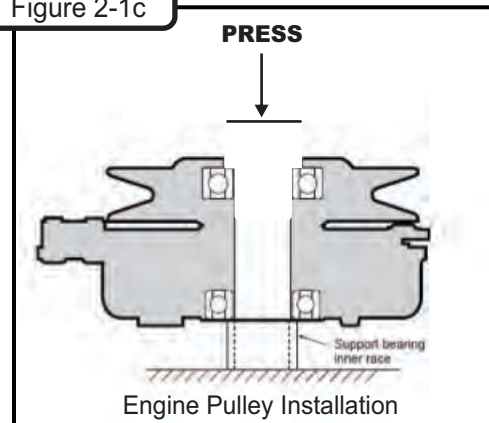

Fasten the A-Section Pulley P#(M0309) to the Pulley Bushing and electric clutch assembly using (1) 7/16" Double Indented Washer P#(K0278), (1) 7/16" Hi-Collar Lock Washer P#(K0140) and (1) 7/16"-20 x 3-3/4" HHCS P#(K0350) as shown in Figure 2-1d. **Torque the bolt to 55 ft-lbs.** Re-connect the wiring harness to the electric clutch.

Figure 2-1d

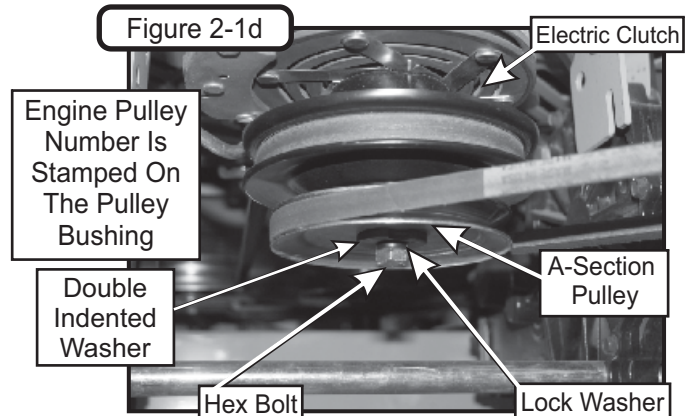

2-2 Mount Arm Preparation and Installation

Remove the (4) 3/8"-16 x 1-1/4" existing Carriage Bolts and (4) 3/8"-16 Ny-Flange Lock Nuts from the right-rear of the mower and discard. Refer to Figure 2-2a.

First, loosely attach the Mount Arm Brace P#(B0953) to the Mount Arm Assy. P#(A2071) using (2) 3/8"-16 x 1" Carriage Bolts P#(K1182) and (2) 3/8"-16 Ny-Flange Lock Nuts P#(K2038). Next, attach both parts to the right rear of the mower using (4) 3/8"-16 x 1-1/2" Carriage Bolts P#(K1337), (2) 3/8"-16 x 1-1/4" Carriage Bolts P#(K1183) and (6) 3/8"-16 Ny-Flange Lock Nuts P#(K2038). Once in place tighten all bolts to suggested torque. Refer to Figure 2-2b.

Figure 2-2a

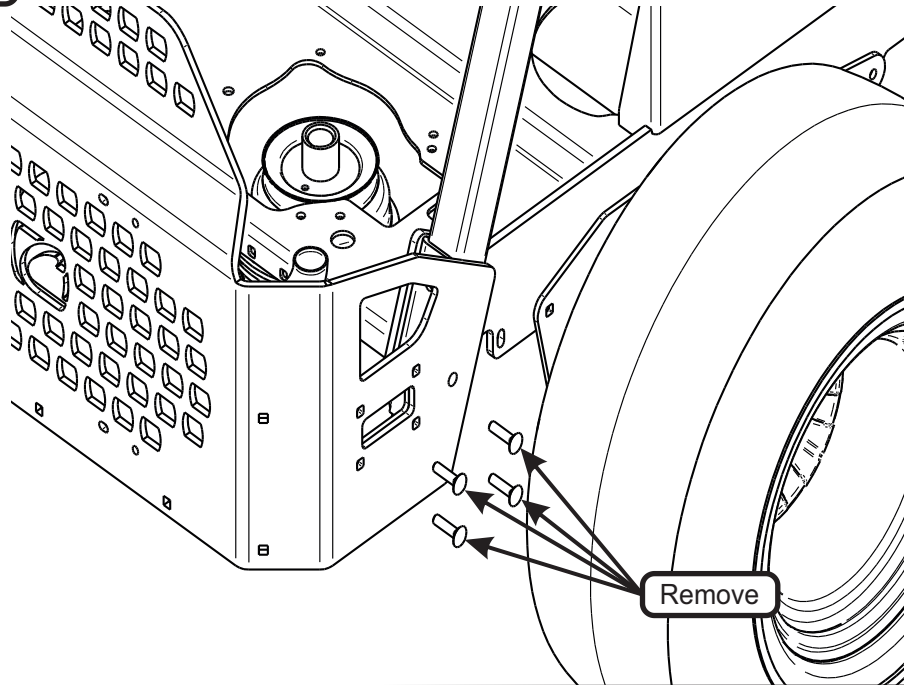
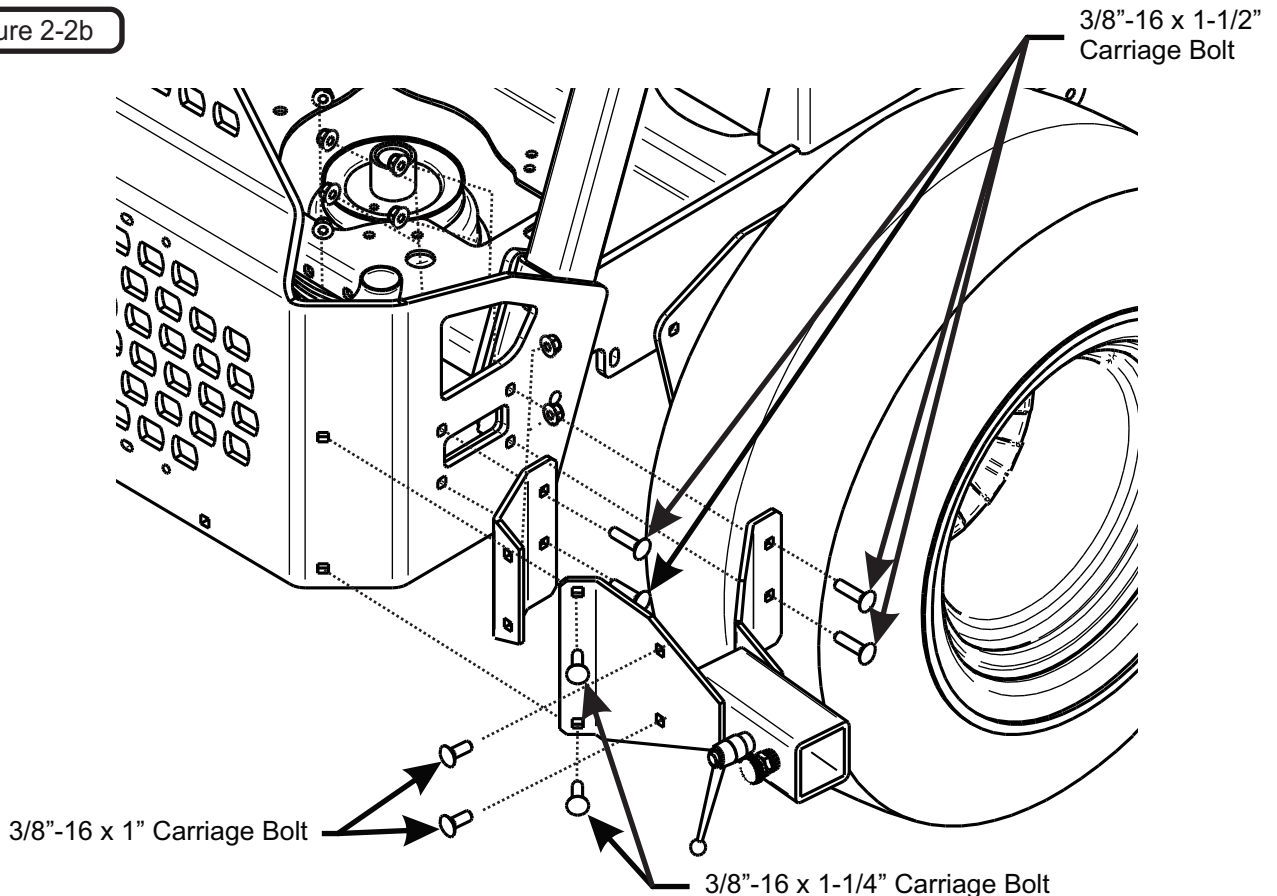

Figure 2-2b



2-3 PTO Drive Assembly

Once the Mount Arm Assembly P#(A2071) is installed and secured to the mower, assemble the Drive Assembly P#(A2072), Belt Guard Assembly P#(A2069_03), Idler Mount Assembly P#(A2067_03) & Belt Guard Gusset P#(B1026).

First, attach the Belt Guard Assembly P#(A2069_03) to the Drive Assembly P#(A2072) using (2) 1/4"-20 x 5/8" Carriage Bolts P#(K1010) and (2) 1/4"-20 Ny-Flange Lock Nuts P#(K2014). Refer to Figure 2-3a. **Leave Bolts Loose.**

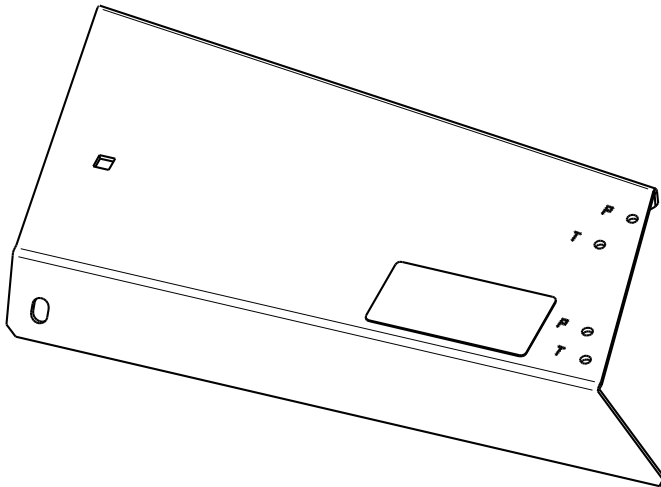

BELT GUARD ASSY. HOLES

Notice Marked Holes Below;
(Use corresponding holes with type of
mower that is being fitted up)

T = Pro Z 500, 700 & 900 Series Mounting Hole
P = Pro Z 100 Series Mounting Hole

Figure 2-3a

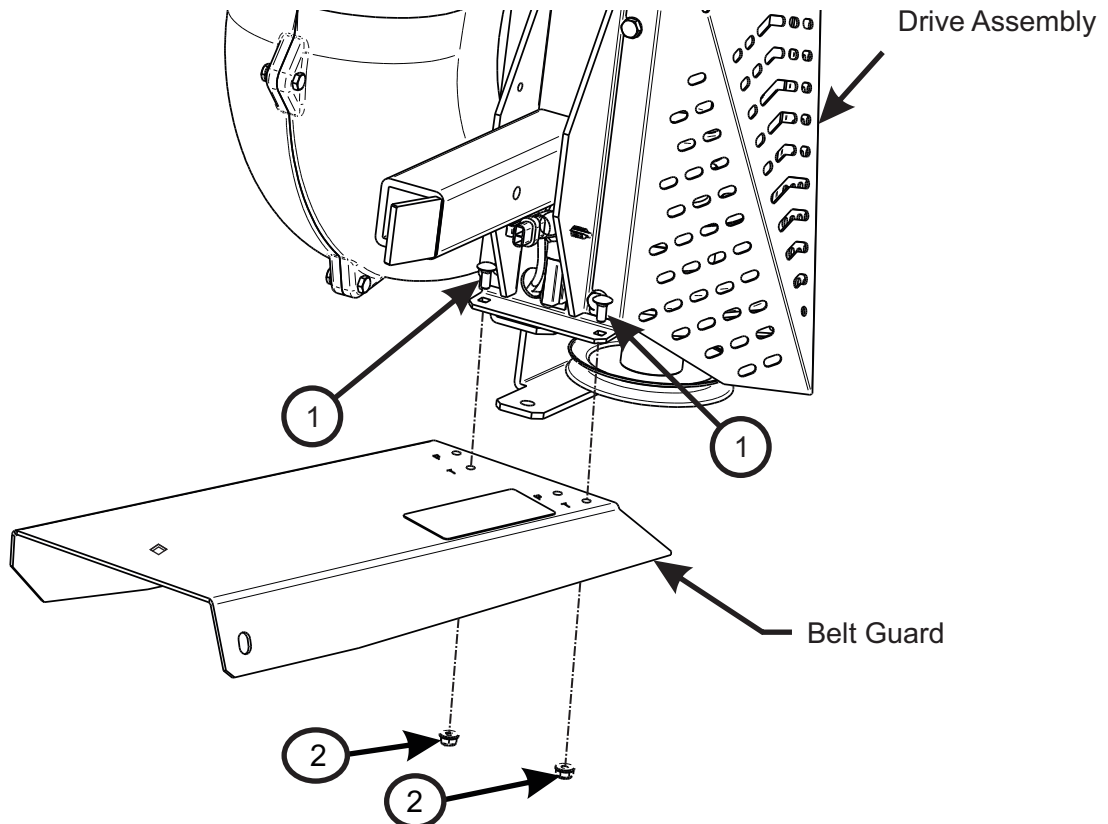

Item #	Part #	Desc.	Qty.
1	K1010	1/4"-20 x 5/8" Carriage Bolt	2
2	K2014	1/4"-20 Ny-Flange Lock Nut	2

2-3 PTO Drive Assembly (Continued)

Attach the Idler Mount Assembly P#(A2067_03) to the Drive Assembly using (1) 3/8"-16 x 1" HHCS (A) P#(K1191), (1) 3/8"-16 x 1" Carriage Bolt (B) P#(K1182) and (2) 3/8"-16 Ny-Flange Lock Nuts P#(K2038). Refer to Figure 2-3b. Leave Bolts Loose (Note: Orientation of bolts A & B).

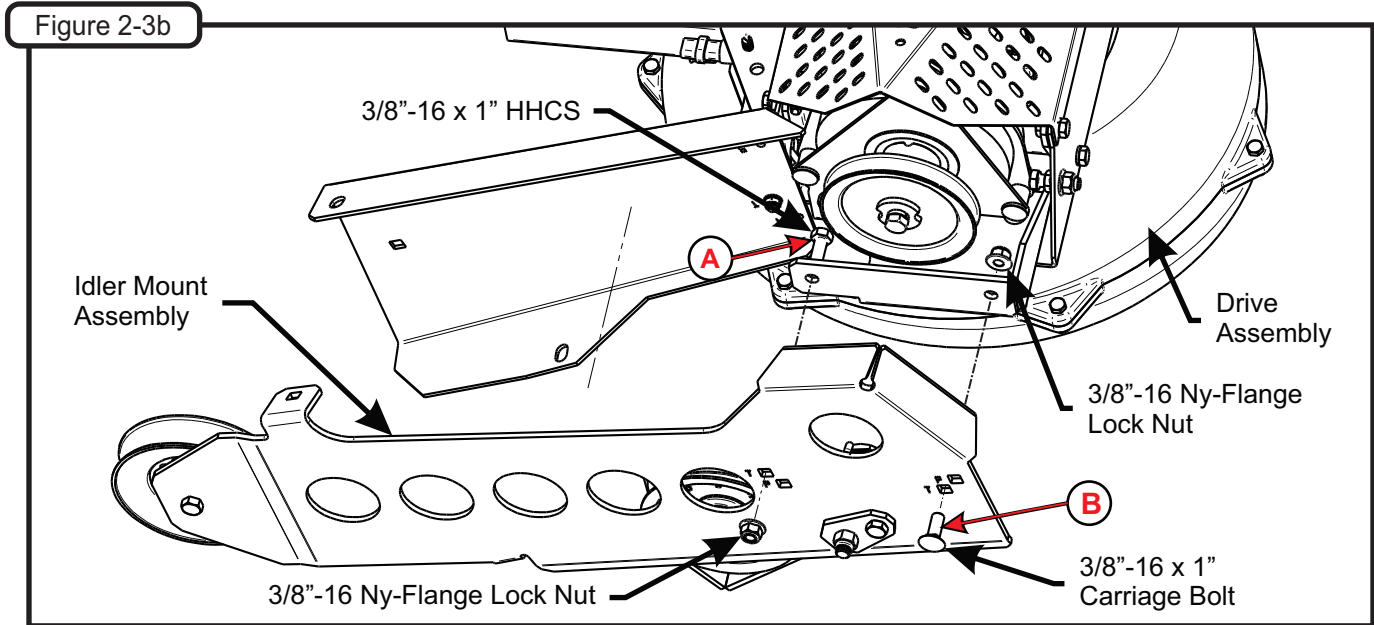

Next, secure the Idler Mount Assembly P#(A2067_03) to the Belt Guard Assembly P#(A2069_03) using (2) 3/8"-16 x 1" Carriage Bolts P#(K1182) and (2) 3/8"-16 Ny-Flange Lock Nuts P#(K2038).

Then, secure the Belt Guard Gusset P#(B1026) to the Belt Guard Assembly using (2) 3/8"-16 x 1" Carriage Bolts P#(K1182) & (2) 3/8"-16 Ny-Flange Lock Nuts P#(K2038). Refer to Figure 2-3c & 2-3d.

Finally, tighten all bolts.

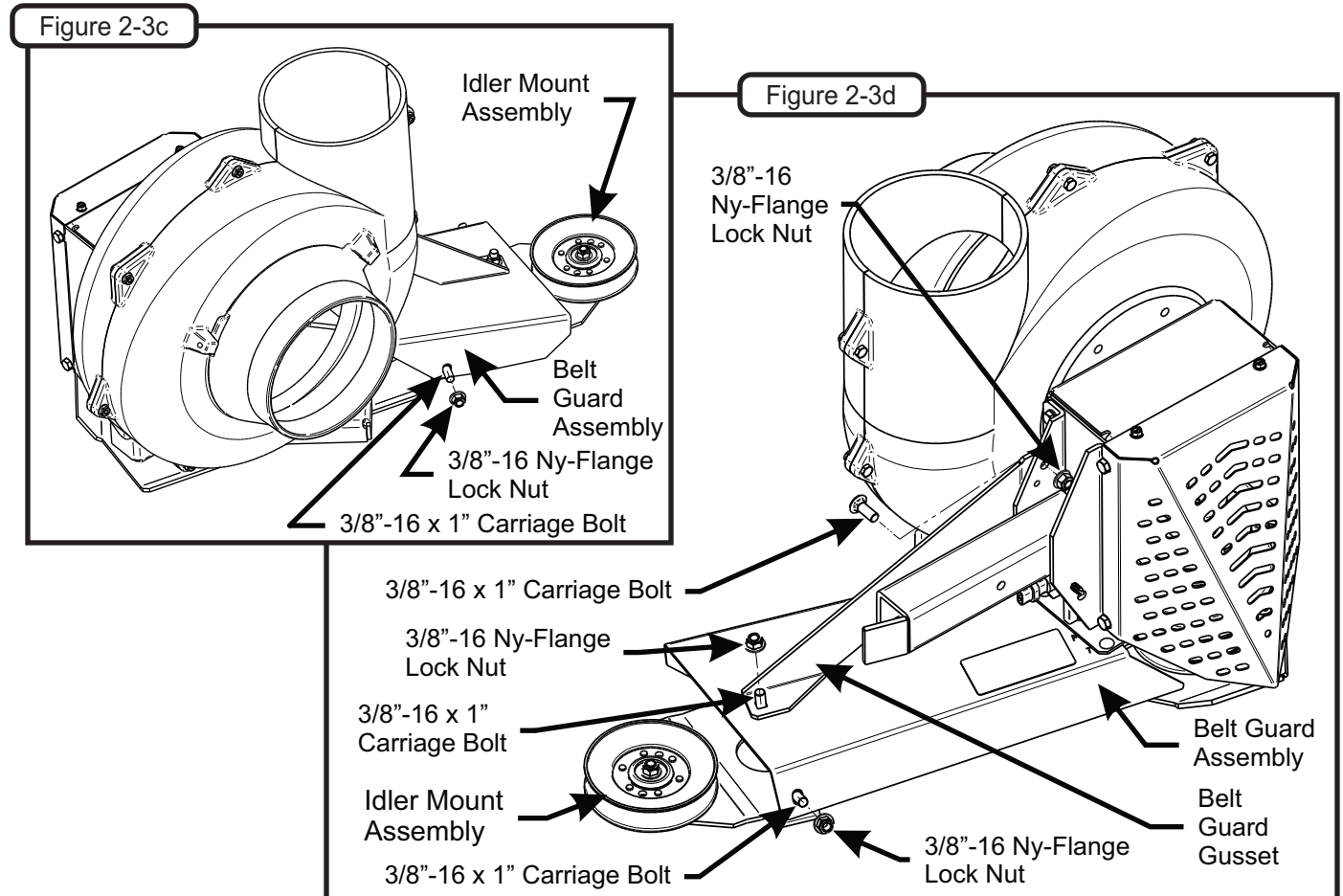

2-4 Drive Assembly and Belt Installation

(Note: It is recommended that someone assist during this step.)

Insert the Drive Assembly into the receiver tube on the Mount Arm Assembly until the Knob Plunger Pin engages. Once in place, turn Lock Handle clockwise until tight. Next, feed the AK87 Belt P#(M0312) between the Belt Guard and the Idler Mount Assembly. Place belt around the Engine Drive Pulley on the underside of the mower. While one person inserts a 1/2" drive tool (socket handle) into the Idler Mount Assembly and rotates lever arm clockwise, enough to relieve all tension from belt, place belt around the Drive Assembly Pulley. Once belt is in position, carefully release the tension to tighten belt.

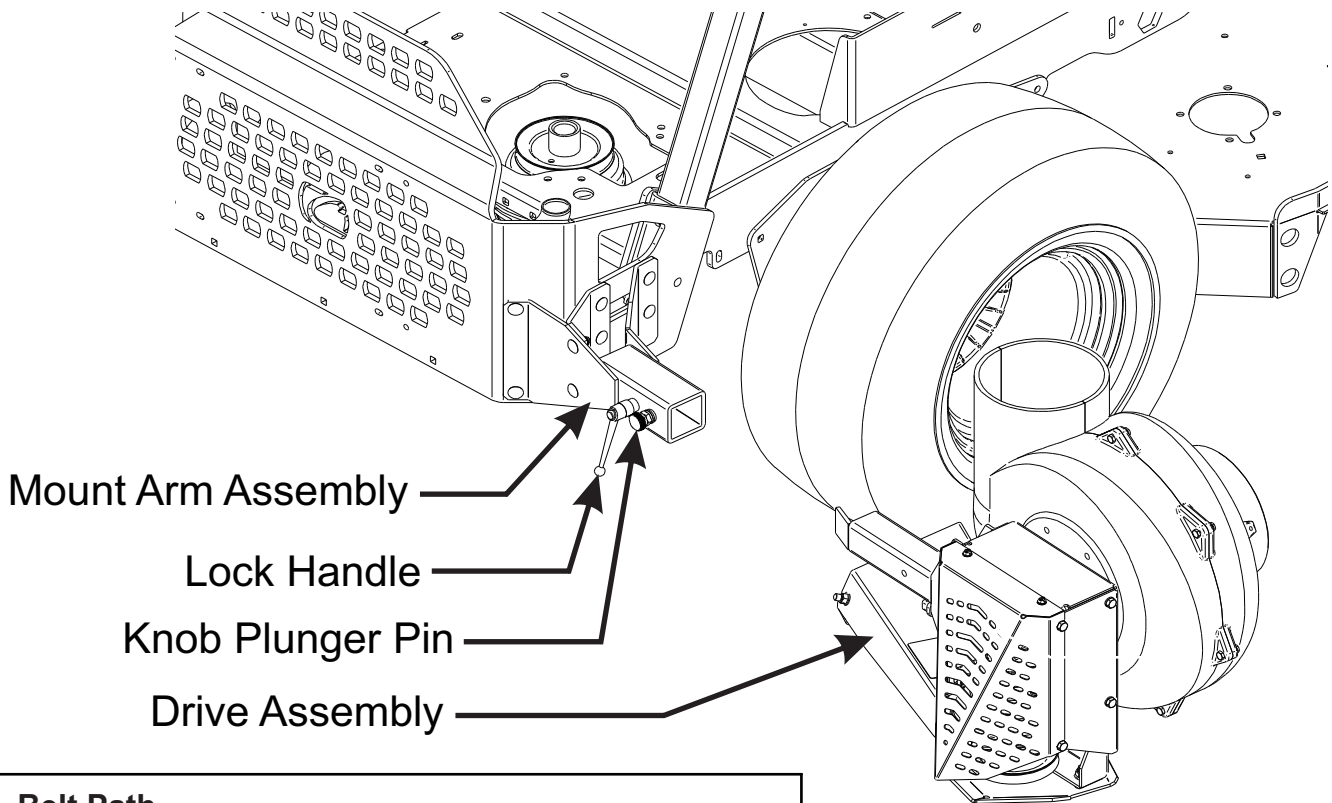

Belt Path

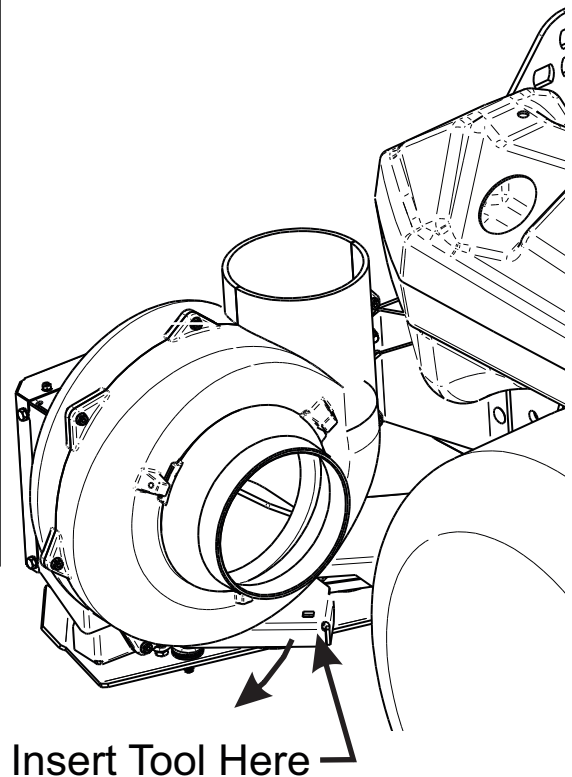
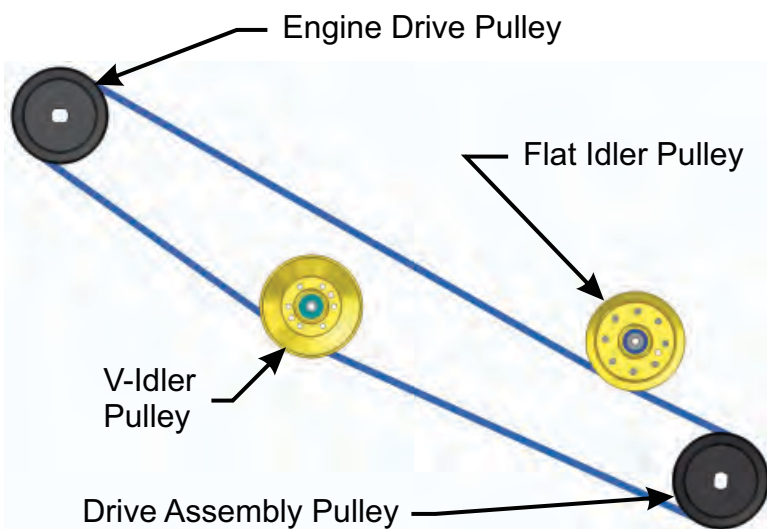

2-5 Lower Main Frame Leg Installation

Loosely connect (1) Left Main Frame Leg P#(B0976) to the Left Frame Leg Brace P#(B0987) using (2) 3/8"-16 x 1" Carriage Bolts P#(K1182) and (2) 3/8"-16 Ny-Flange Lock Nuts P#(K2038). Secure (1) Right Main Frame Leg P#(B0975) to the Right Frame Leg Brace P#(B0986) using (2) 3/8"-16 x 1" Carriage Bolts P#(K1182) and (2) 3/8"-16 Ny-Flange Lock Nuts P#(K2038). Next, position the two parts inside the rear frame and secure using (1) 3/8"-16 U-Bolt P#(K1119), (2) 3/8"-16 Ny-Flange Lock Nuts, (2) Existing 3/8"-16 x 1-1/2" Carriage Bolts and (2) Existing 3/8"-16 Ny-Flange Lock Nuts per side. Tighten all fasteners installed. Refer to Figure 2-5.

Figure 2-5

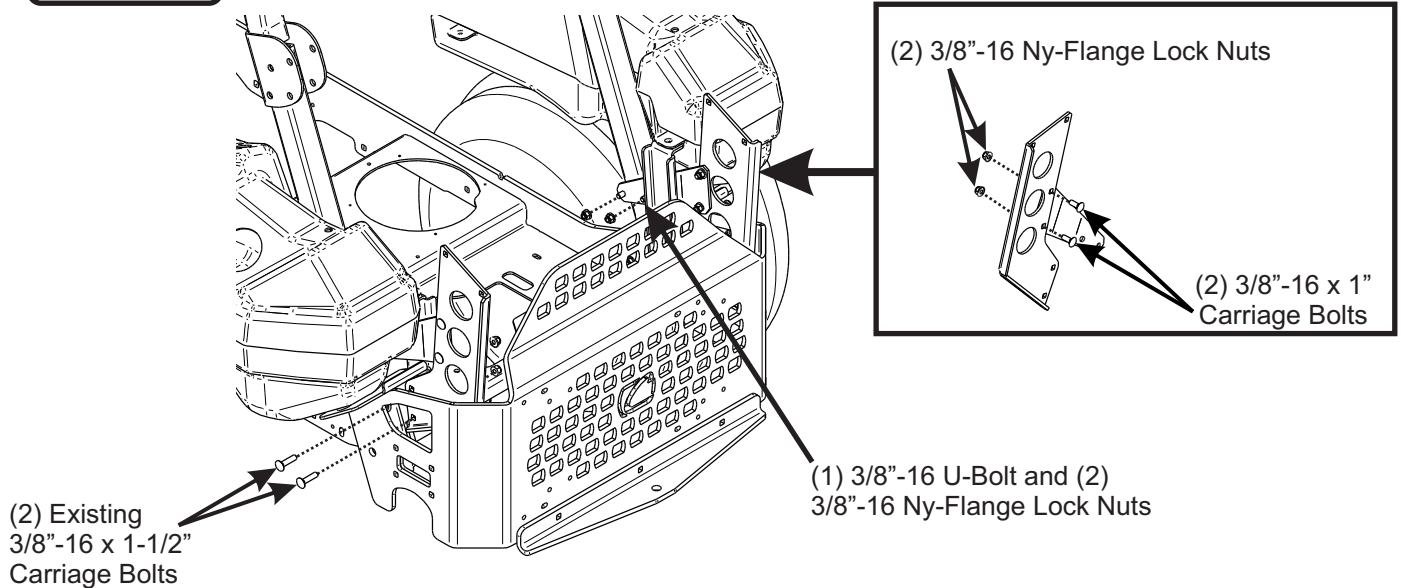

2-6 Main Frame Assembly Installation

Lift the Main Frame Assembly P#(A1192) into position. Space each Frame Bracket using (1) Frame Spacer P#(B0977) per outer side of the Frame and secure to the Lower Main Frame Legs using (4) 3/8"-16 x 1-1/4" Carriage Bolts P#(K1183) and (4) 3/8"-16 Ny-Flange Lock Nuts P#(K2038). Refer to Figure 2-6.

Figure 2-6

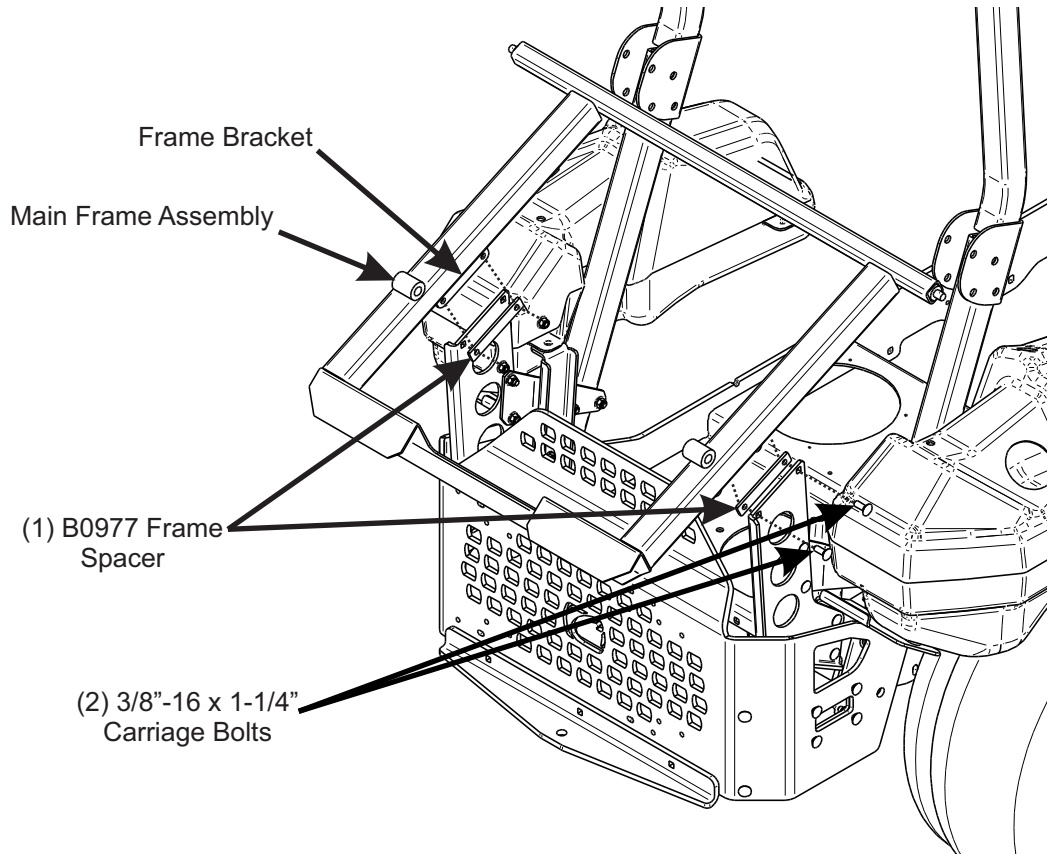

2-7 Lift Handle Installation

NOTE: Before continuing the Lift Handle installation, have someone assist you in turning the Box Assembly upside down. Insert (1) 3/8"-16 x 2" HHCS P#(K1208) into the Lift Handle P#(A0897), and secure with (1) 3/8"-16 Flange Nut P#(K1215). Thread the flange nut onto the bolt upside down, as shown in Figure 2-7a. Do not tighten the nut fully at this time.

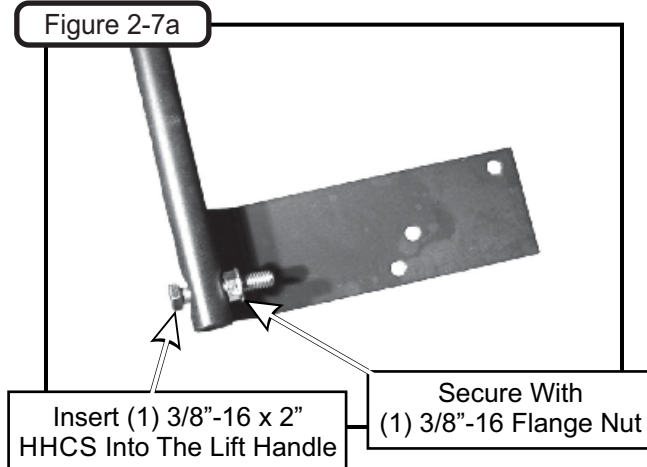

Slide the Lift Handle through the slot on the Handle Mount Bracket. Insert the Lift Handle into the Box Frame as shown in Figure 2-7b, and secure using (1) 3/8"-16 Flange Nut P#(K1215) on the inside of the Box as shown in Figure 2-7c. Now test the movement of the handle. It should have full-range of movement in the slot. If the handle does not have full-range of movement, adjust the 3/8"-16 Flange Nut from step 2-7a. Once achieved, tighten the fasteners.

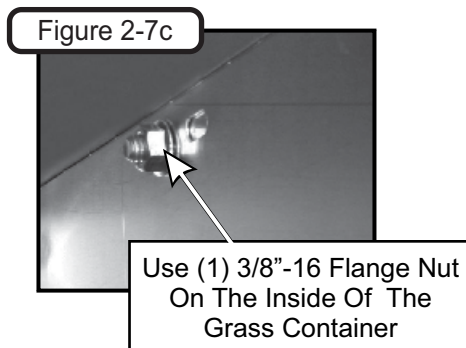
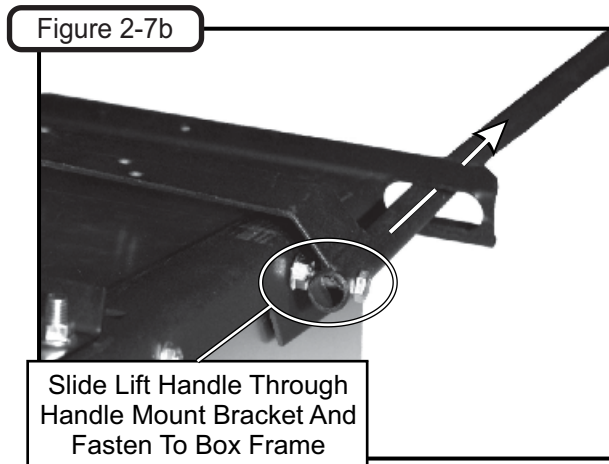

Fasten the Ball Joint P#(K1442) to the end of the Latch Rod P#(A2107). Tighten the Ball Joint to approximately half-way down the threads on the Latch Rod. Attach the Ball Joint to the Latch Hook as shown in Figure 2-7d, using (1) 5/16"-24 Hex Nut P#(K1444) and (1) 5/16" Lock Washer P#(K0043).

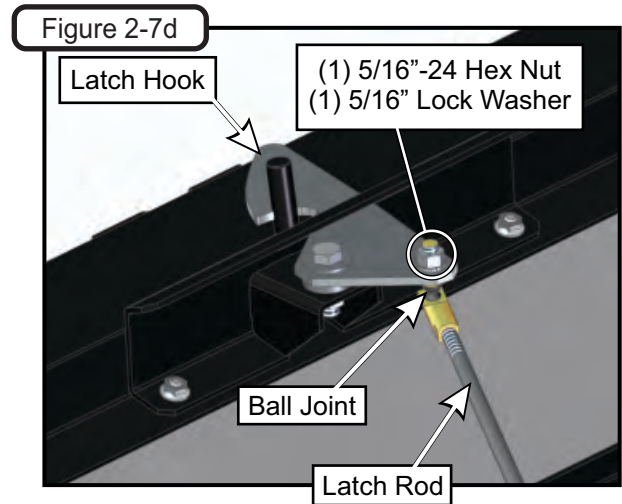

Attach the other end of the Latch Rod to the Lift Handle, as shown in Figure 2-7e. Attach one end of the Spring P#(J0176) to the Lift Handle and the other end of the Spring to the Handle Mount Bracket as shown in Figure 2-7f. Adjust the Ball Joint up or down on the Latch Rod threads until the Latch Hook closes completely. After adjusting the Latch Hook, secure the Latch Rod to the Lift Handle using (1) Cotter Pin P#(K0094).

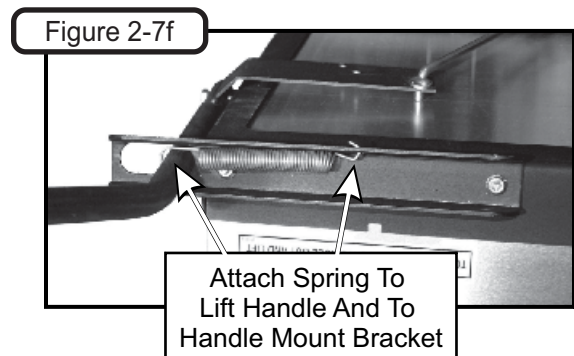
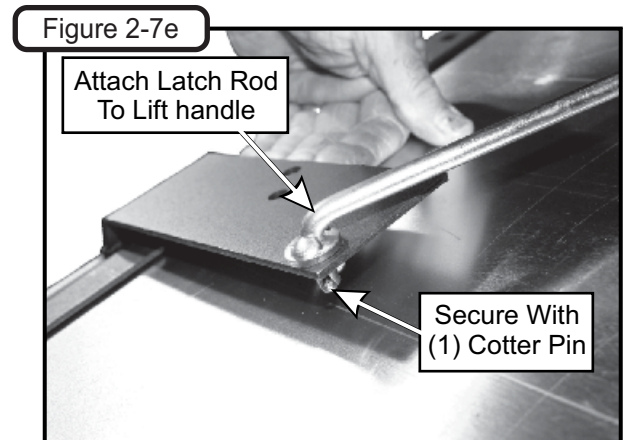

2-8 Aluminum Box Assembly Installation

NOTE: It is recommended that two extra people assist in mounting the Box Assembly. Two can lower the Box onto the frame while the third person inserts the Pivot Pins P#(K0172) through the holes. Insert the Pins from the outside to the inside. Secure with (1) 5/8" Washer P#(K0058) and (1) 5/32" x 2-5/8" Hair Pin Clip P#(K0088) per Pivot Pin (Figure 2-8b). Reattach the bottom ends of the door opening linkages to the Main Frame by using (1) Rue-Ring Cotter Pin P#(K1437) per side. To test the functionality of the dump mechanism, pull the Lift Handle away from the unit, and lift upward. The Door of the Box Assembly should open and the Box should pivot clockwise towards the ground.

Figure 2-8a

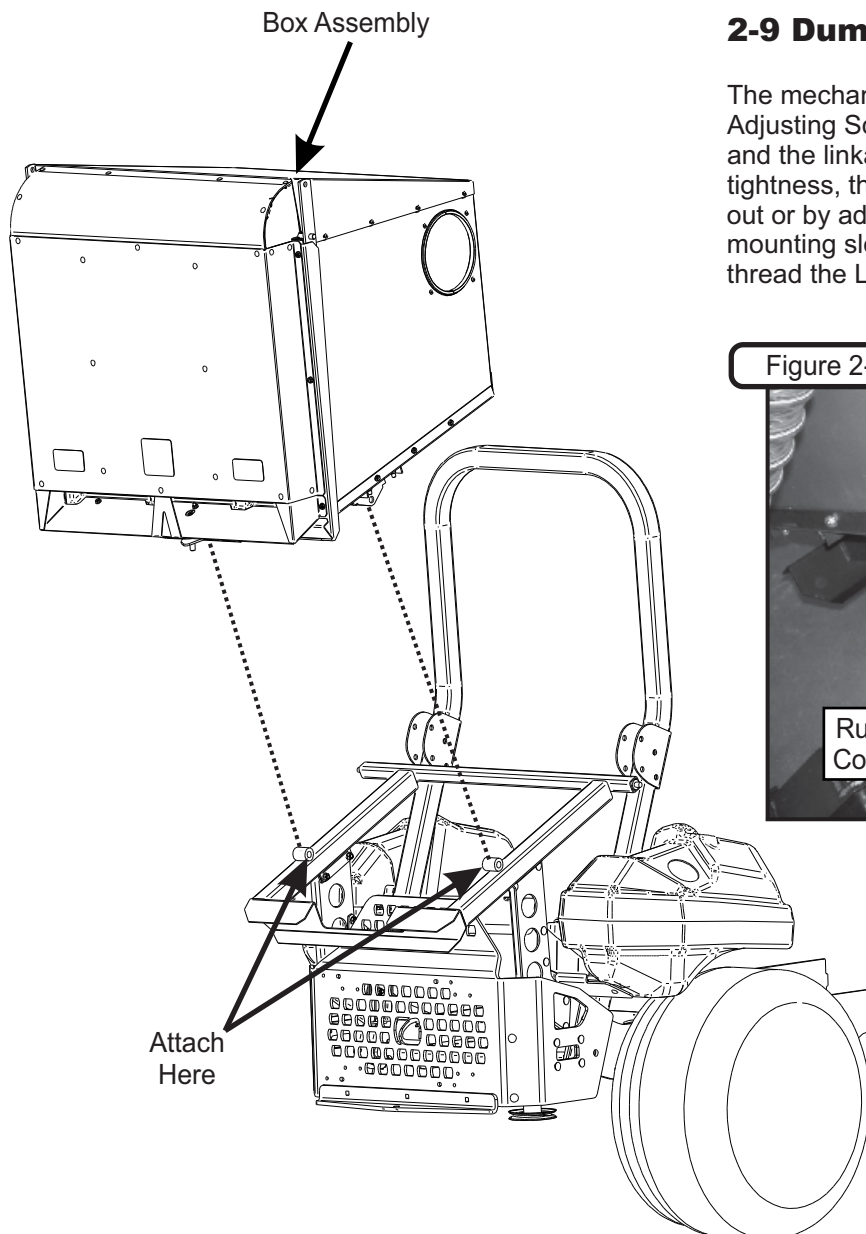
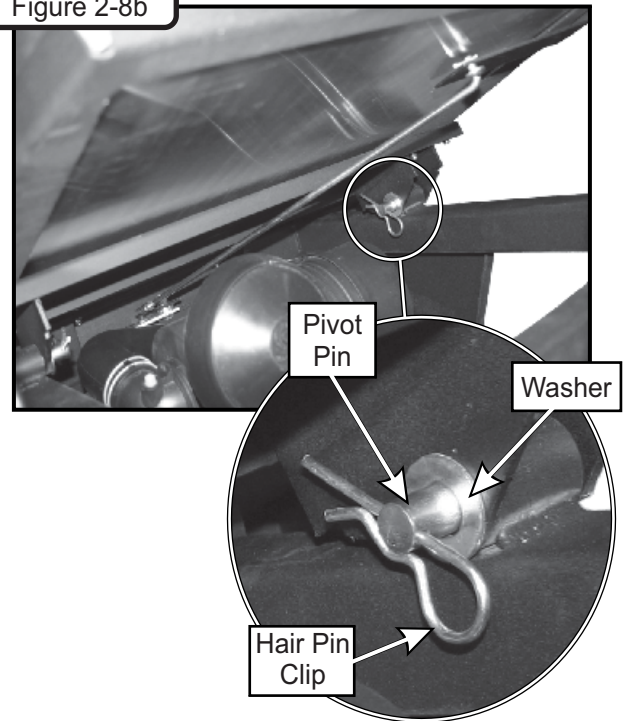

Figure 2-8b



2-9 Dump Mechanism Adjustment

The mechanism may be adjusted in three places, at the Adjusting Screw P#(K1435), at the Latch Hook Pivot Bolt and the linkage Ball Joint. To change the door closure tightness, thread the Adjusting Screw (Figure 2-9) in or out or by adjusting the Latch Hook Pivot Bolt within its' mounting slot. To adjust the Latch Hook closure angle, thread the Linkage Ball Joint in or out.

Figure 2-9

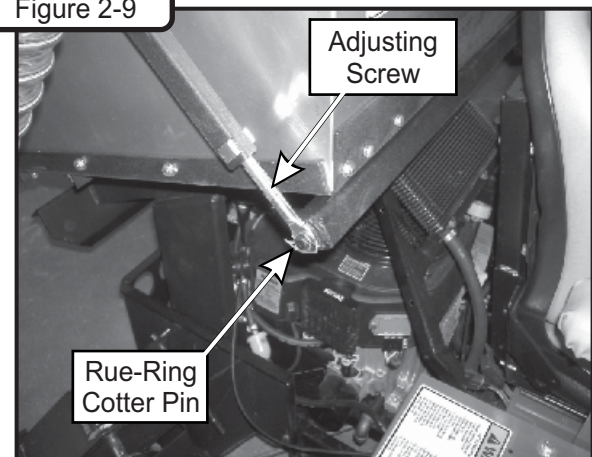

2-10 Inlet, Inlet Ring & Debris Deflector Installation

Open box door. From inside box, slide Inlet (#1) halfway into inlet hole (See Figure 2-10a). Take each half of the Inlet Ring (#2) and attach around matching groove in Inlet (#1). Slide Inlet (#1) & Inlet Ring (#2) against inlet hole and align four holes. Fasten Inlet Ring (#2) bottom holes using (2) 5/16" IT Tooth Lock Washers (#5) & (2) 5/16"-18 x 1/2" HHCS (#6) (See Figure 2-10b). Fasten Inlet Ring (#2) top holes using (2) 5/16" IT Tooth Lock Washers (#5) & (2) 5/16"-18 x 1-1/4" HHCS (#4). Slide Debris Deflector (#3) over inside top bolt threads (#4). Fasten Debris Deflector (#3) using (2) 5/16"-18 Ny-Flange Lock Nuts (#7). Final assembly should resemble Figure 2-10c.

Figure 2-10a

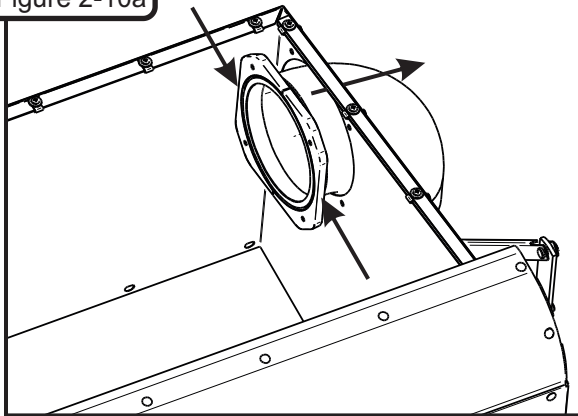

Figure 2-10c

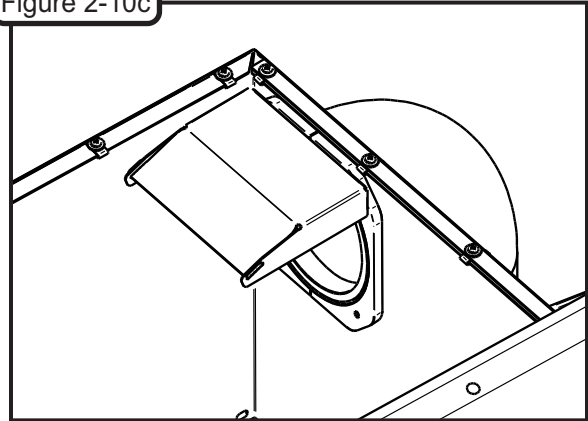
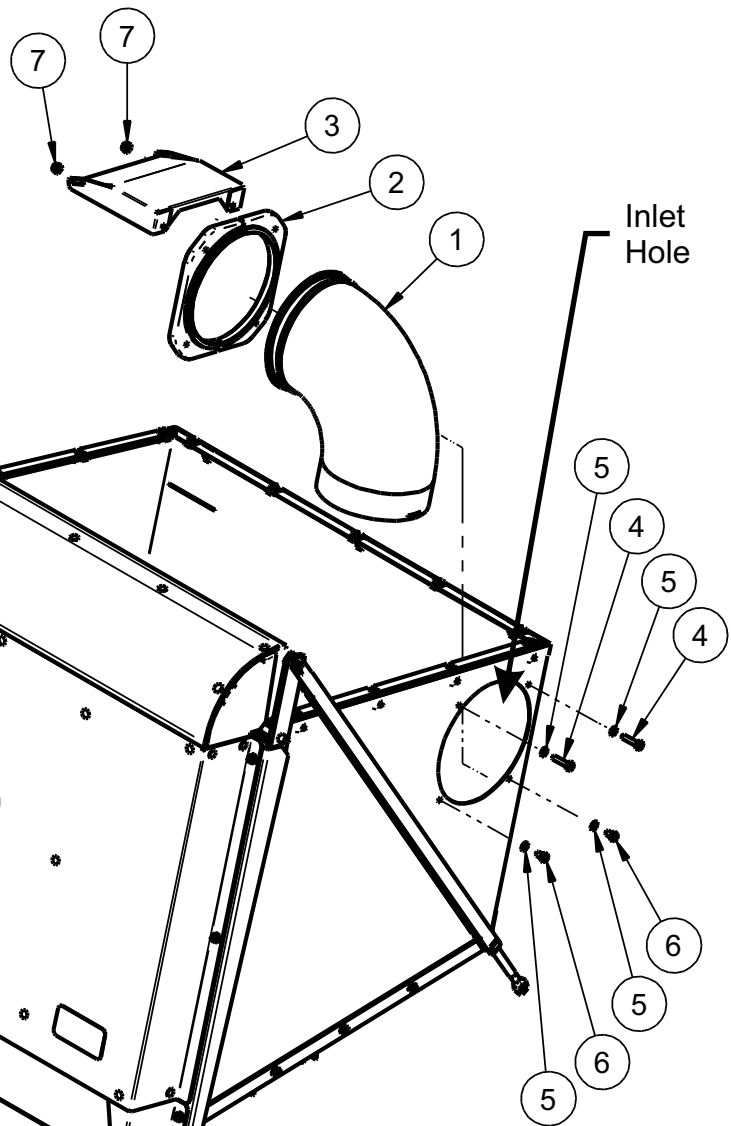

Figure 2-10b

Item #	Part #	Desc.	Qty.
1	A2074	P3B Inlet w/ Snap Fastener	1
2	C0074	Inlet Ring	1
3	C0088	Debris Deflector	1
4	K1156	5/16"-18 x 1-1/4" HHCS	2
5	K0044	I/T Tooth Lock Washer 5/16"	4
6	K1152	HHCS 5/16"-18 x 1/2"	2
7	K2516	Ny-Flange Lock Nut 5/16"-18	2



Open Box Door
To Assemble Inlet,
Inlet Ring & Debris
Deflector

Note: Box Top & Screen Removed
In Figure Above For Visual Clarity.

2-11 Blower Cone Installation

Thread (1) 5/16"-18 Jam Nut P#(K0120) onto each end of (2) 5/16"-18 x 2-1/2" HHCS P#(K0125) as shown in Figure 2-11a.

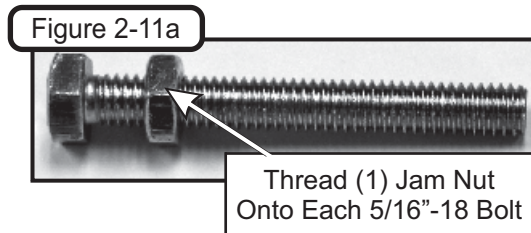

Now partially thread (1) bolt into each of the two threaded bosses located on the Blower Housing. Place 8" Blower Cone P#(E6008) so the two tabs line up with the bolts and tighten completely as shown in Figure 2-11b.

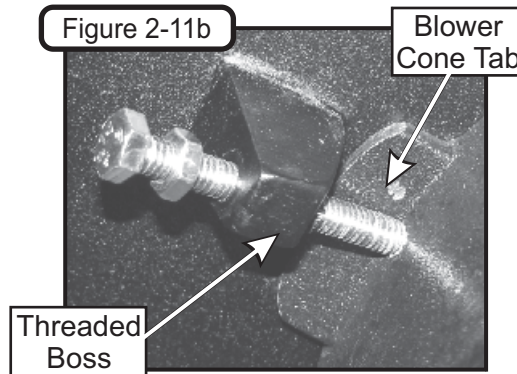

Once the (2) bolts are tight, tighten the Jam Nuts against the threaded boss as shown in Figure 2-11c.

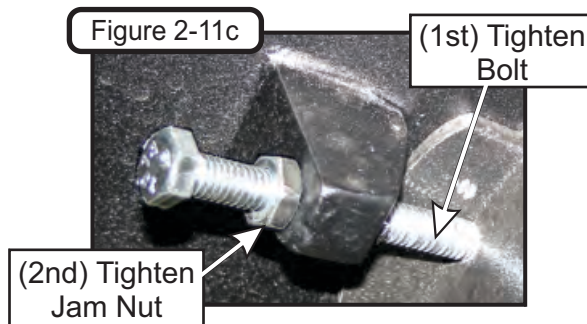

Refer to Figure 2-11d for proper Blower Cone installation reference.

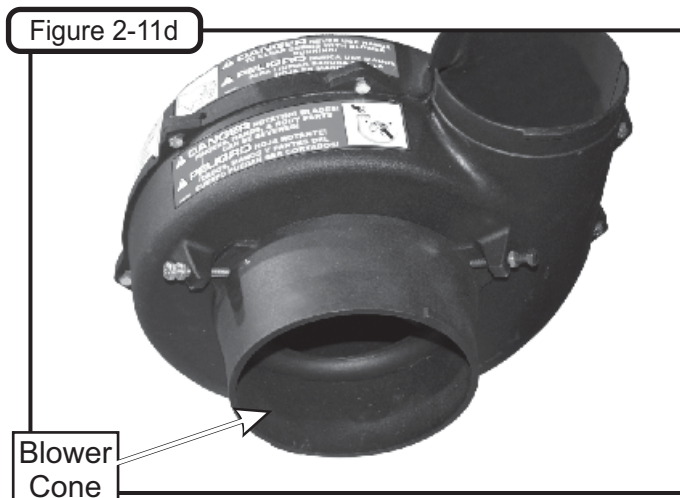

2-12 Boot To Mower Deck Installation

NOTE: The boot kit assembly is designed to fit the 54" and 60" deck. To ensure a snug fit between the boot and the mower deck, follow the instructions in this step thoroughly, and remove and tighten all hardware in the sequence specified.

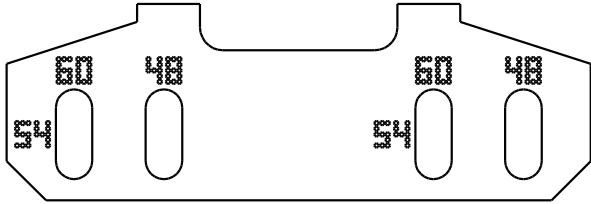

According to deck size, align marked holes and Boot holes. Secure the Boot Mounting Assembly P#(A2045) to the Aluminum Boot P#(E0028A) using (2) 3/8"-16 x 1" Carriage Bolts P#(K1182) and (2) 3/8"-16 Ny-Flange Lock Nuts P#(K2038). Insert the Carriage Bolts from the inside of the Boot so the threads are on the outside of the Boot (Figure 2-12a). This will prevent grass clippings from collecting on the bolt threads. Leave bolts loose for alignment once installed on mower.

After removing only the Wing Knobs, align the threaded mount posts on the Boot Mounting Assembly with the mounting holes located above the mowers discharge chute and insert into the mounting holes. Secure with the (2) Wing Knobs P#(J0018). Press Boot against discharge chute, to ensure a snug fit and tighten the two nuts on top of the boot. Refer to Figure 2-12b.

Note: Deflector not shown for clarity but must be installed during normal operation.

Figure 2-12a

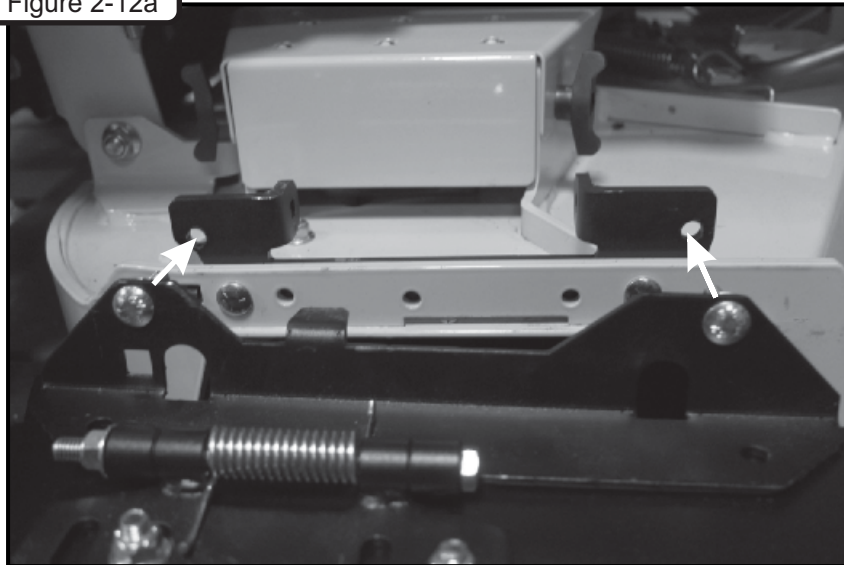
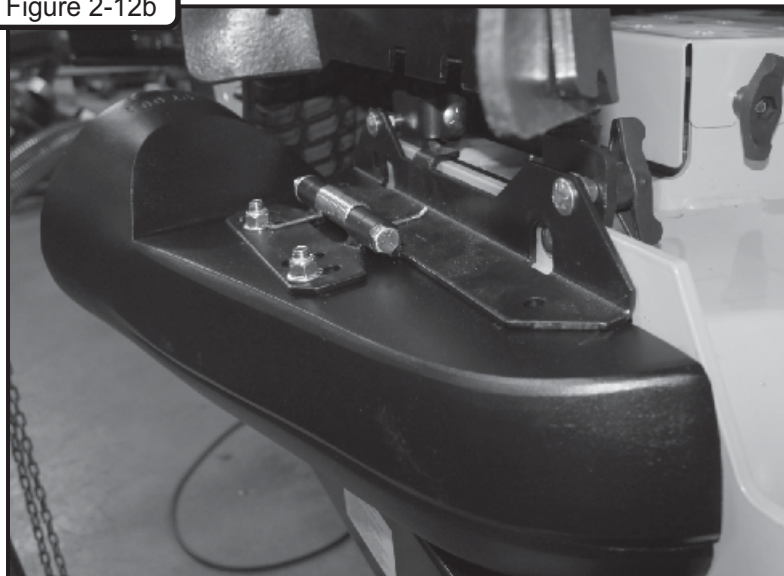

Figure 2-12b



2-13 Length Of Hose Adjustment

The hoses in the following steps must be cut to fit your machine. Do not cut the hoses until you have tried to fit them on your machine. Remember that the hoses need to be long enough to allow for the opening and closing of the collection system as well as allowing ample clamping surface between each component.

2-14 Upper Hose Installation

Slide a pre-assembled Hose Clamp P#(J0070) over one end of the 7" Upper Hose. Secure this end of the 7" Upper Hose to the Blower Outlet. See Figure below for details. Secure opposite end of the 7" Upper Hose to the Inlet. Make sure both ends are securely fastened by tightening the Hose Clamp and rotating the Inlet Snap Fastener towards the hose to lock in place.

2-15 Lower Hose To Blower Cone Installation

Slide a pre-assembled Hose Clamp P#(J0080) over both ends of the Lower Hose. Secure one end of the Lower Hose to the Blower Cone and fasten by tightening the Hose Clamp.

2-16 Lower Hose To Boot Installation

Take the unattached end of the Lower Hose and secure it to the circular end of the Boot and fasten by tightening the Hose Clamp (Figure 2-14). Tip: Before securing Hose Clamp fully, rotate Lower Hose counter-clockwise (away from yourself) approximately 1" to aid in retaining Boot to mower deck.

Figure 2-14

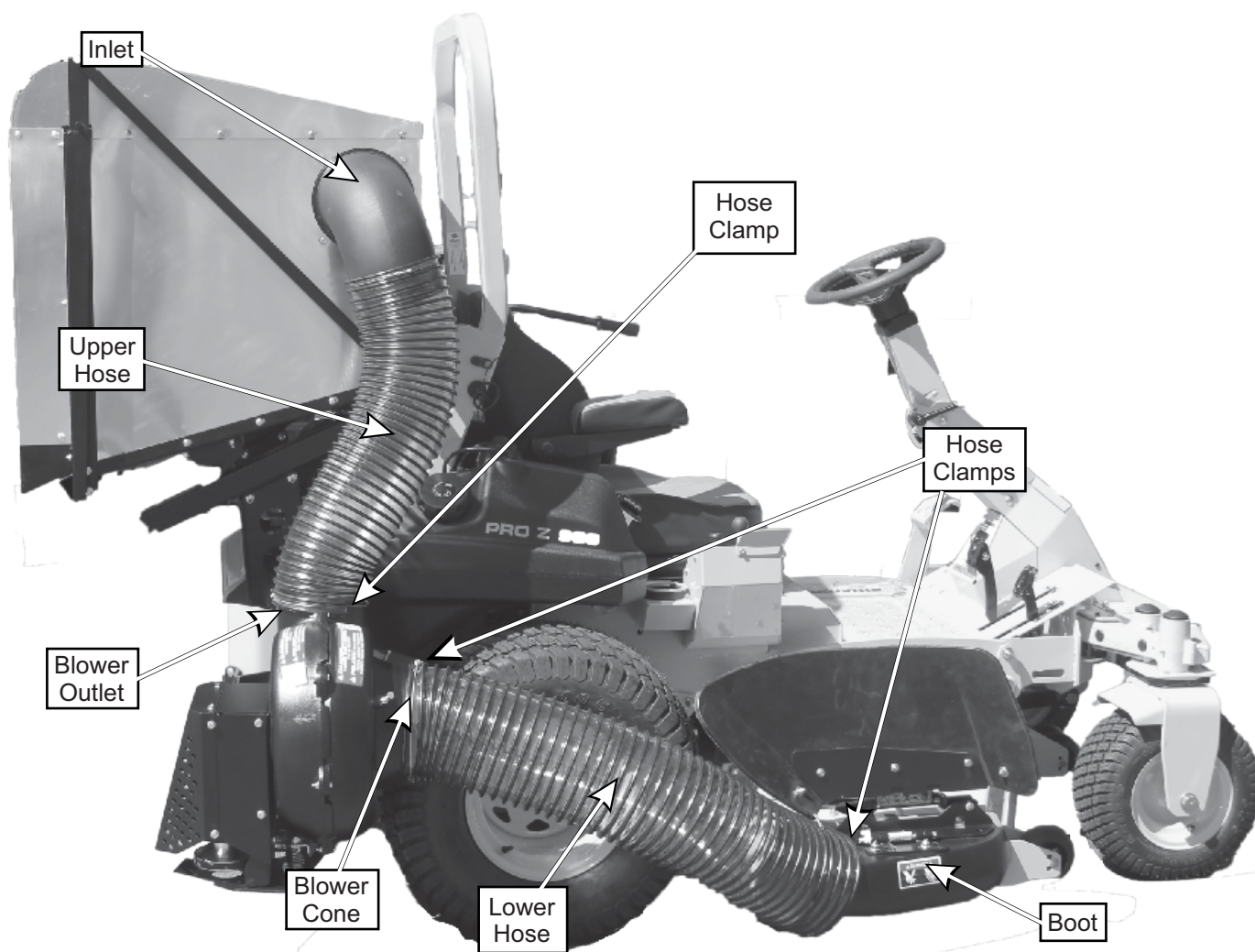

2-17 Safety Interlock Harness Installation

Collection System May Require Dealer Installation!

Before installing, please verify the presence of an auxiliary 5-way female connector in the mower's electrical harness. The connector is located underneath the operator's seat in between the two hydraulic pump cooling fans.



WARNING

**To Prevent Serious Injury-
Proper Installation Of Safety Interlock Harness
Is Mandatory. Please Check That All Interlock
Points Work Correctly Once Installed.**

Connect (A) the Delphi 5-way Male Connector, on the harness, to the connection point under the seat and between the two cooling fans. Next, on the left side of the engine locate and separate the engine harness from the mower's main harness. Connect (B) to the engine side connector and (C) to the main harness connector. Refer to Figure 2-17a & 2-17b.

Route the Drive Clutch Connector (D) around the front side of the engine, between the ROPS and gas tank and through the opening in the rear bumper connecting to the quick connect plug located on the PTO Drive.

Before routing the PTO Switch (E), locate and remove knock out on the mower's control panel. The control panel is easily accessed by removing the (9) hex head screws around the outside of the control panel housing. Route (E) through the frame and up to the underside of the control panel. Insert switch into the hole, previously knocked out, and snap the provided retaining plate to the underside of the control panel. The retainer plate (F) should be seated fully over the snap wings of switch from the underside of the panel after the switch is installed. Connect the switch to connector and reattach control panel.

Use the zip ties that are provided to secure in place.

Figure 2-17a

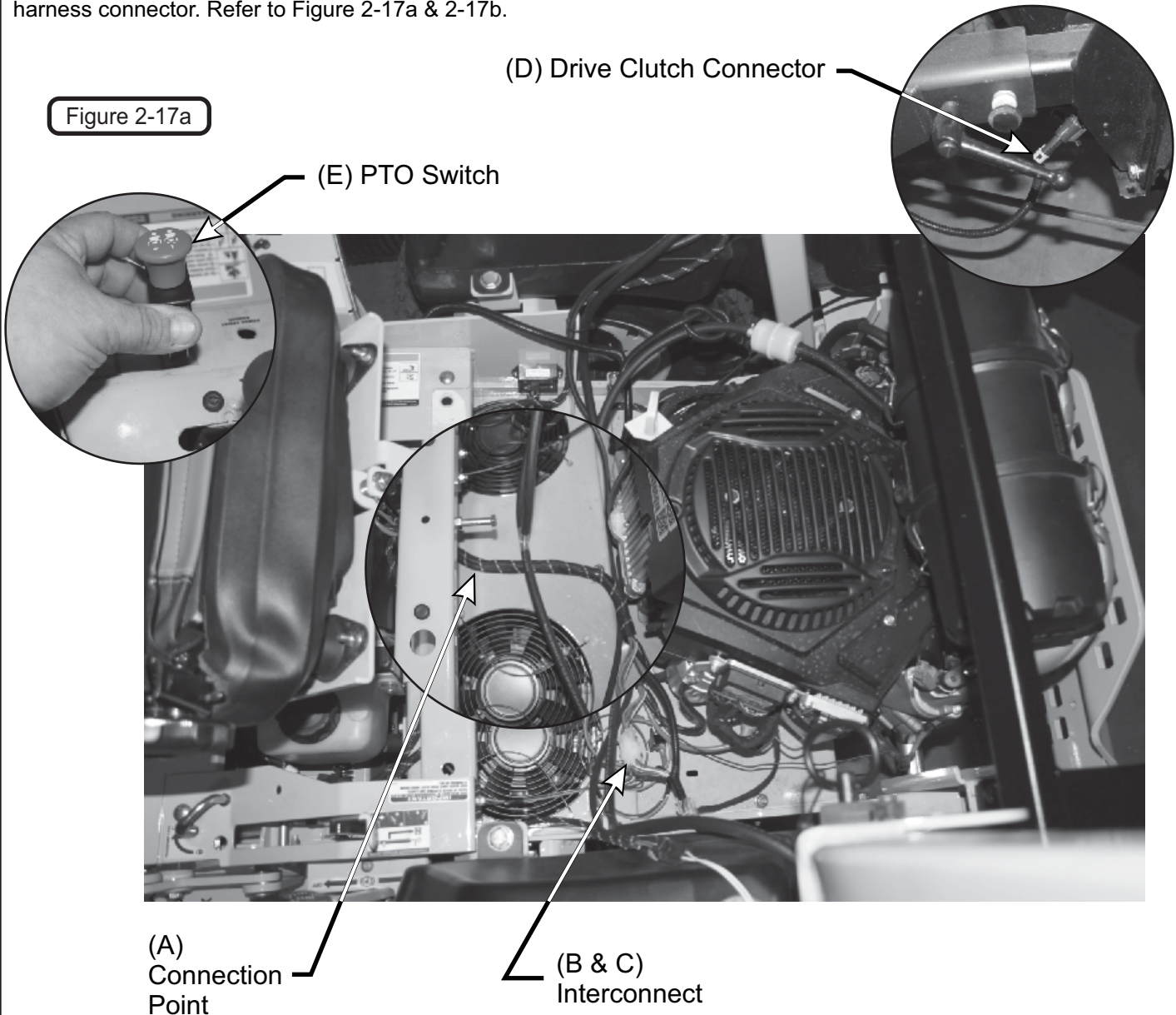

2-17 Safety Interlock Wiring Harness Installation (Continued)

Figure 2-17b

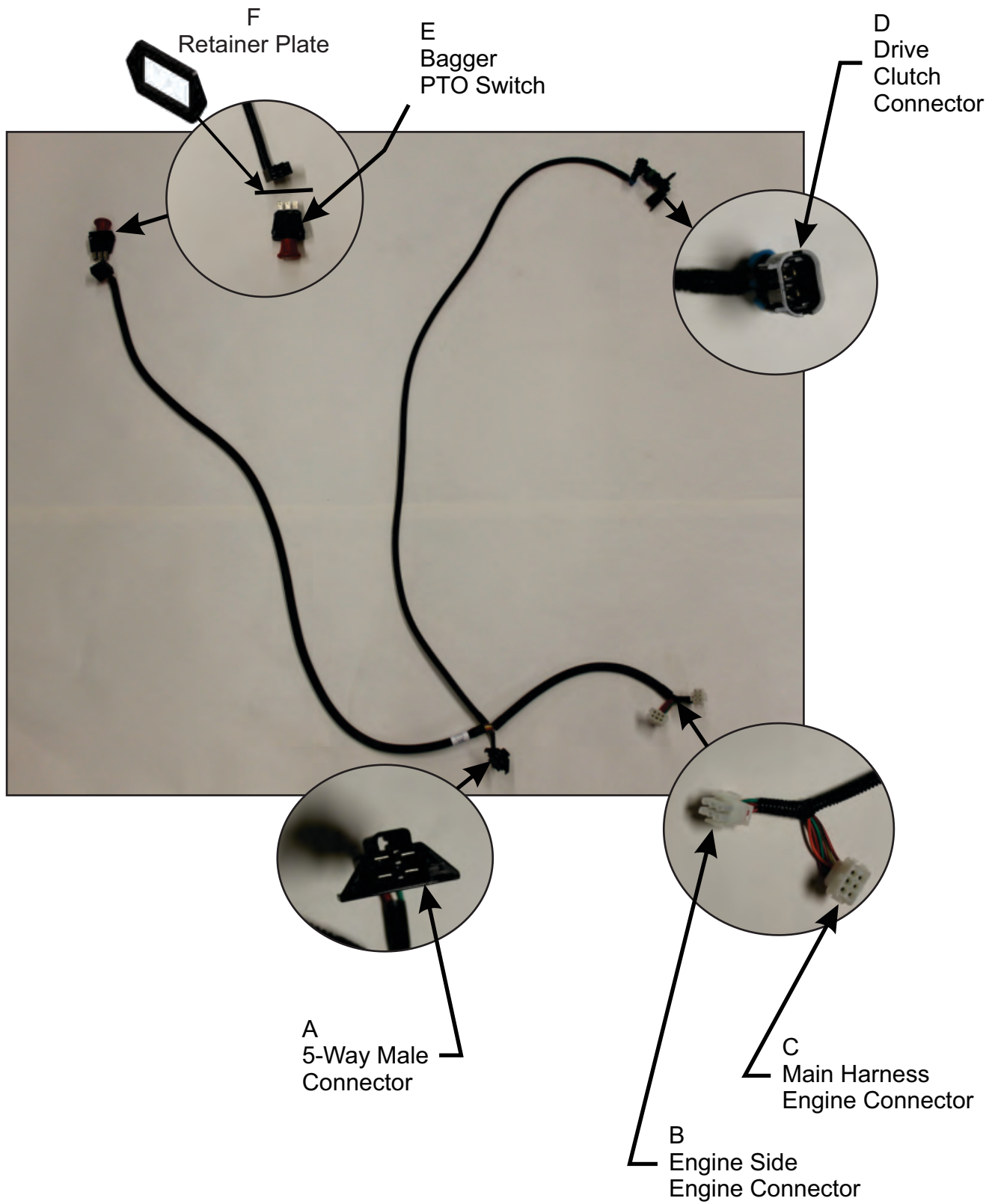

2-17 Safety Interlock Harness Installation (Continued) Wiring Schematic

P0274 Rev. 1

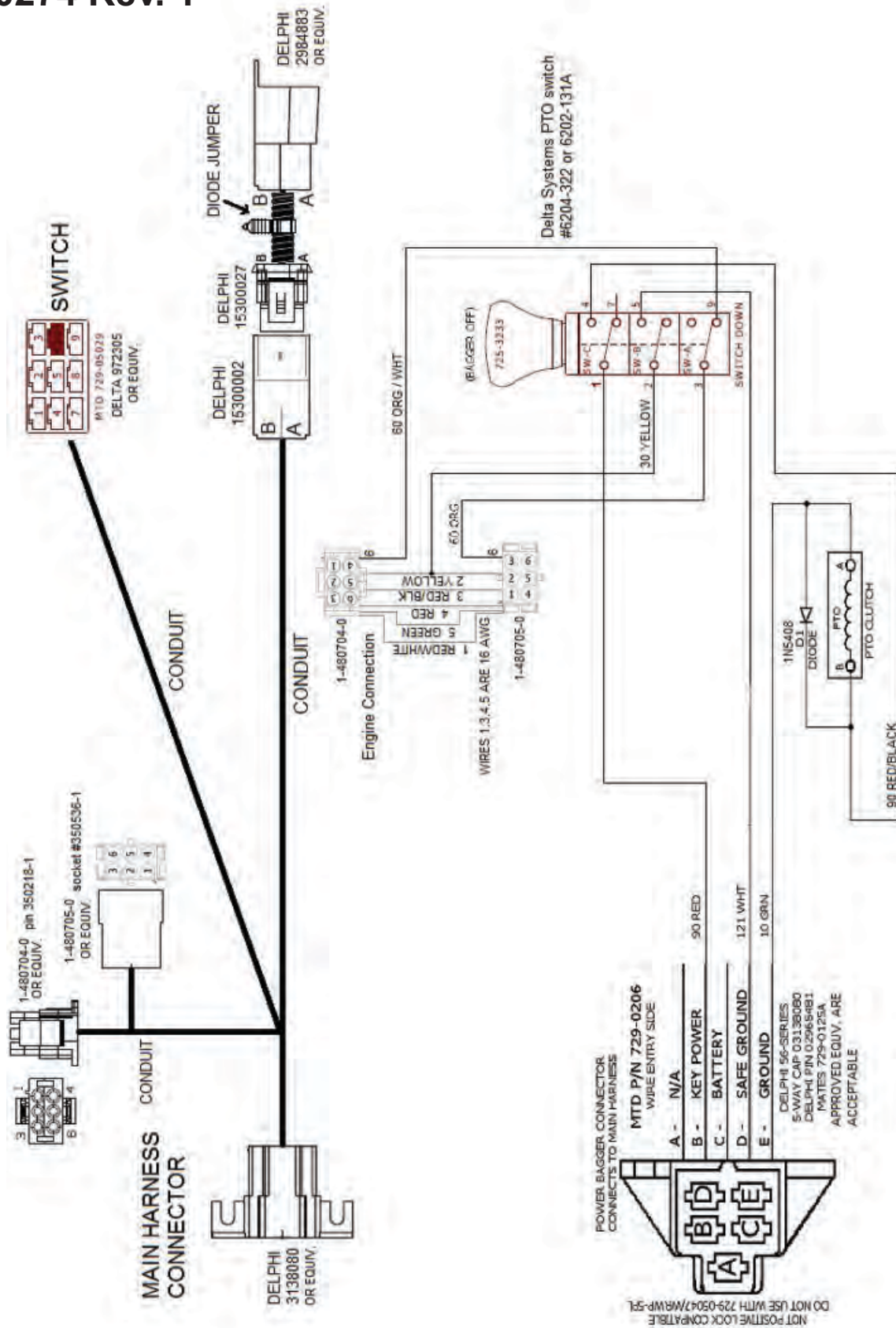

2-18 Impeller Blade Removal/Replacement

To Remove: First remove the 5/16"-24 x 1-1/2" HHCS GR8 P#(K1465) (#1), Taper-Lock Bushing Washer P#(K0284) (#3) and (2) Spacer Bushings P#(S0159) (#4) from the Taper-Lock Bushing P#(S0157) (#5). See Figure 2-18. Next remove the (2) 1/4"-20 x 1" HHCS (#2) and place them into the threaded holes of the Taper-Lock Bushing (#5). Gradually thread each bolt evenly into the Taper-Lock Bushing, forcing the Impeller Blade to break-away from the Taper-Lock Bushing. If the Impeller Blade will not move, carefully hit the base of the Impeller Blade, between each vein, with a hammer, then try again.

To Replace: Place Impeller Blade over the engine shaft. Slide the Taper-Lock Bushing P#(S0157) (#5) on to the engine shaft and into the Impeller Blade, aligning the **non-threaded** holes of the Taper-Lock Bushing to the threaded holes of the Impeller Blade. Fasten by using (2) 1/4"-20 x 1" HHCS (#2), (2) Spacer Bushing P#(S0159) (#4) (1) Taper-Lock Bushing Washer P#(K0284) (#3), and (1) 5/16"-24 x 1-1/2" HHCS P#(K1465) (#1). Torque to the proper specifications in the torque chart within the last pages of this manual. Next, rotate the Impeller Blade to ensure that the Blade is clear of contact on all sides of the Blower Housing.

Figure 2-18

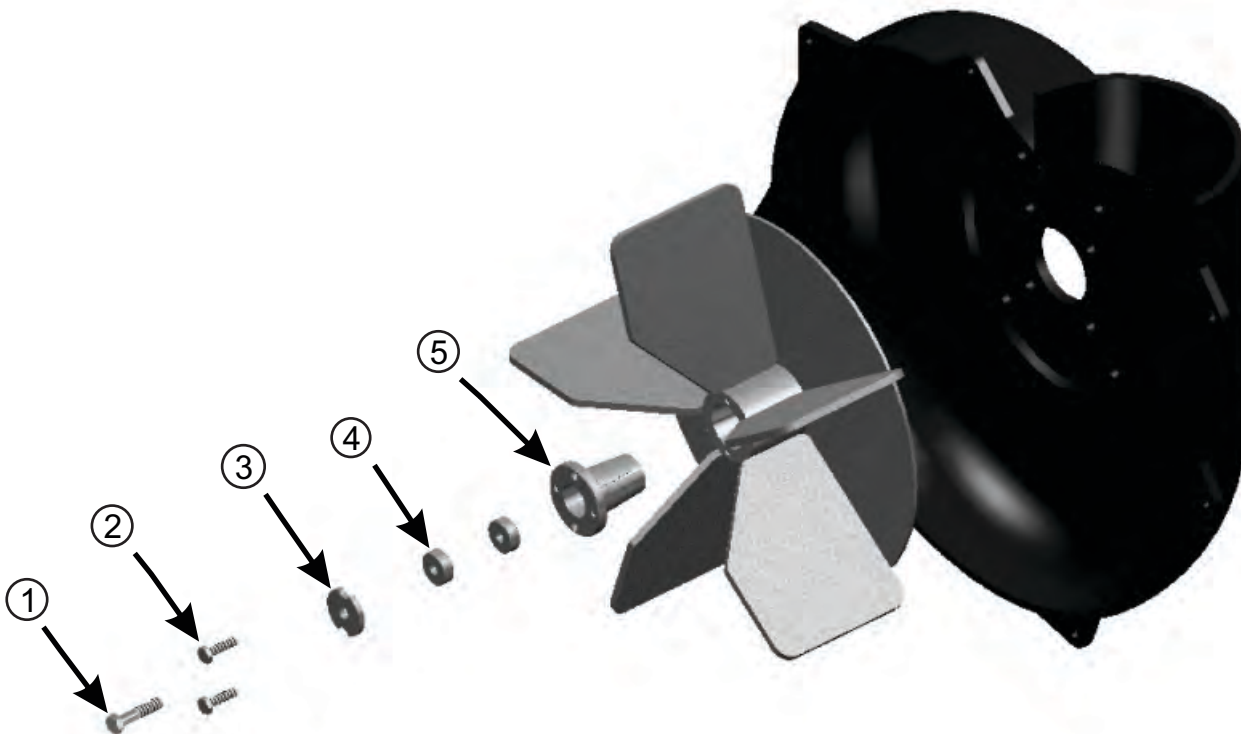

59B30037150 (A1149) -

Weight Kit Installation Instructions

Cub Cadet Tank LZ & L Models - Installing a weight kit is mandatory for safe operation of the collection system. SZ & S Models do not require a weight kit.

Completely thread (2) 3/8"-16 flange nuts P#(K1215) onto (1) 3/8"-16 U-bolt P#(K0407). Repeat process again to create two sets. Secure each U-Bolt, w/ attached flange nuts, to the weight bracket P#(B0703) using (2) 3/8"-16 nylon flange locknuts P#(K2038) as shown in Figure 1-1.

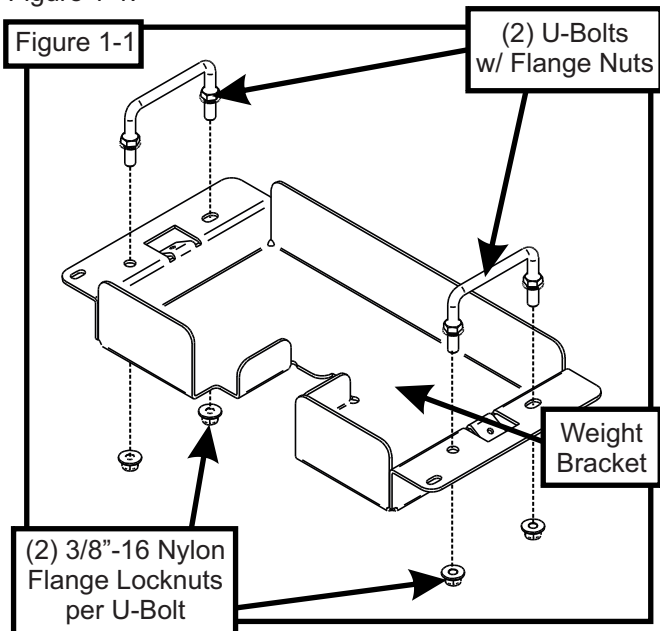

Remove the mower's pulley access cover shown in Figure 1-2.

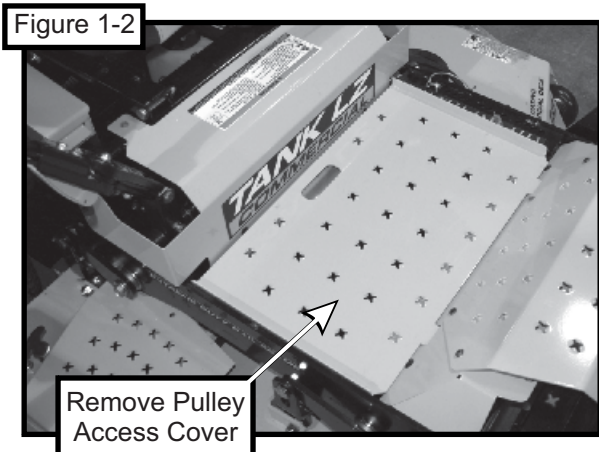

Insert the weight bracket assembly into the recess as shown in Figure 1-3. Align the weight bracket's mounting holes to the mower's frame and secure using (2) 5/16"-18 x 3/4" Carriage Bolts P#(K1142) and (2) 5/16"-18 nylon flange locknuts P#(K2516). Insert the bolts from the bottom of the weight bracket so that the nuts fasten to the top of the bracket as shown in to Figure 1-3.

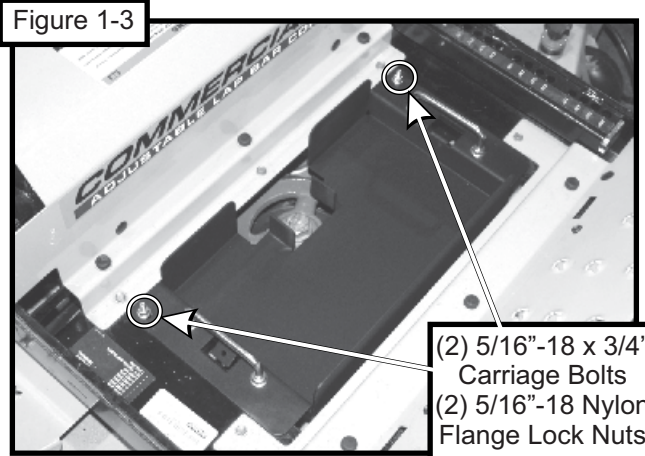

One at a time, add (1) large weight bar P#(B0704) to the weight bracket, then (2) small weight bars P#(B0741). Refer to Figure 1-4.

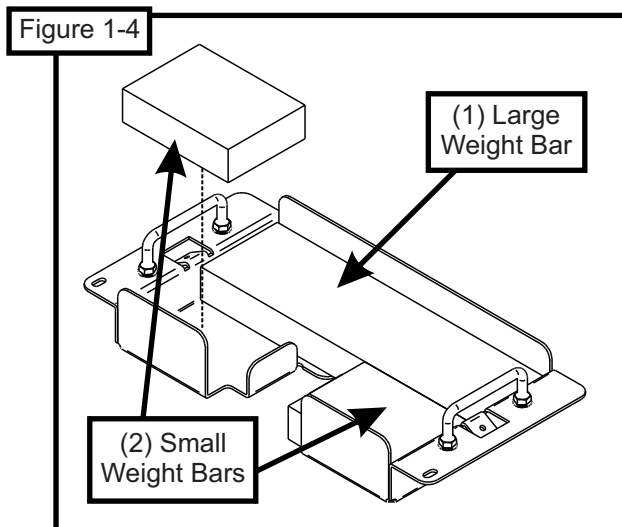

Add the remaining (2) large weight bars P#(B0704) to the weight bracket. Secure the weights to the weight bracket with (1) weight strap P#(B0719) and (2) 1/4"-20 self-tapping screws P#(K0353). Refer to Figure 1-5. Replace mower's pulley access cover when completed.

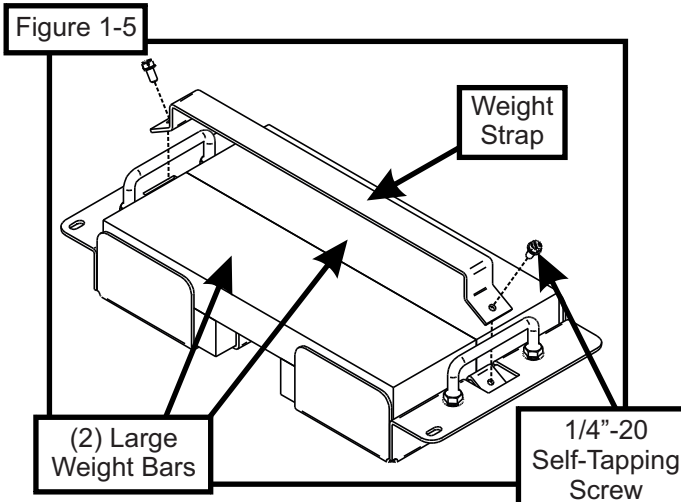

A2100 6512 Explosion

Item #	Part #	Desc.	Qty.
1	B1750	Base Frame	1
2	B1727	Base Frame Pivot Mount	1
3	B1574	Pivot Bracket	2
4	C0024	Box Bottom	1
5	C0080	Box Back & Sides	1
6	C0081	Box Top	1
7	A0938	Frame Weldment / Box Opening	1
8	V1131	12 Box Door	1
9	A0738	Frame Weldment / Door Stiffener	1
10	B1730	Latch Handle Mount Bracket	1
11	B0996	Latch Hook	1
12	C0075	Dust Diverter	1
13	V0051	Dust Flap	1
14	B3688	Upper Door Member	1
15	C0076	Left Dust Diverter Brace	1
16	C0077	Right Dust Diverter Brace	1
17	C0079	Right Outer Dust Flap Brace	1
18	C0078	Left Outer Dust Flap Brace	1
19	B0991	Dust Diverter Guard Bracket	1
20	A2104	Latch Mount Plate Assy.	1
21	V0052A	Dust Seal / Top Sides	1
22	V0052B	Dust Seal / Long Door Sides	2
23	B1006	Dust Flap Stiffener	1
24	B1007	Screen Clamp Strip / Side	2
25	C0087	Screen Support	1
26	V0052C	Dust Seal / Short Door Sides	2
27	B1008	Screen Clamp Strip / Rear Door	1
28	B8113	Screen / Steel Wire Mesh	1

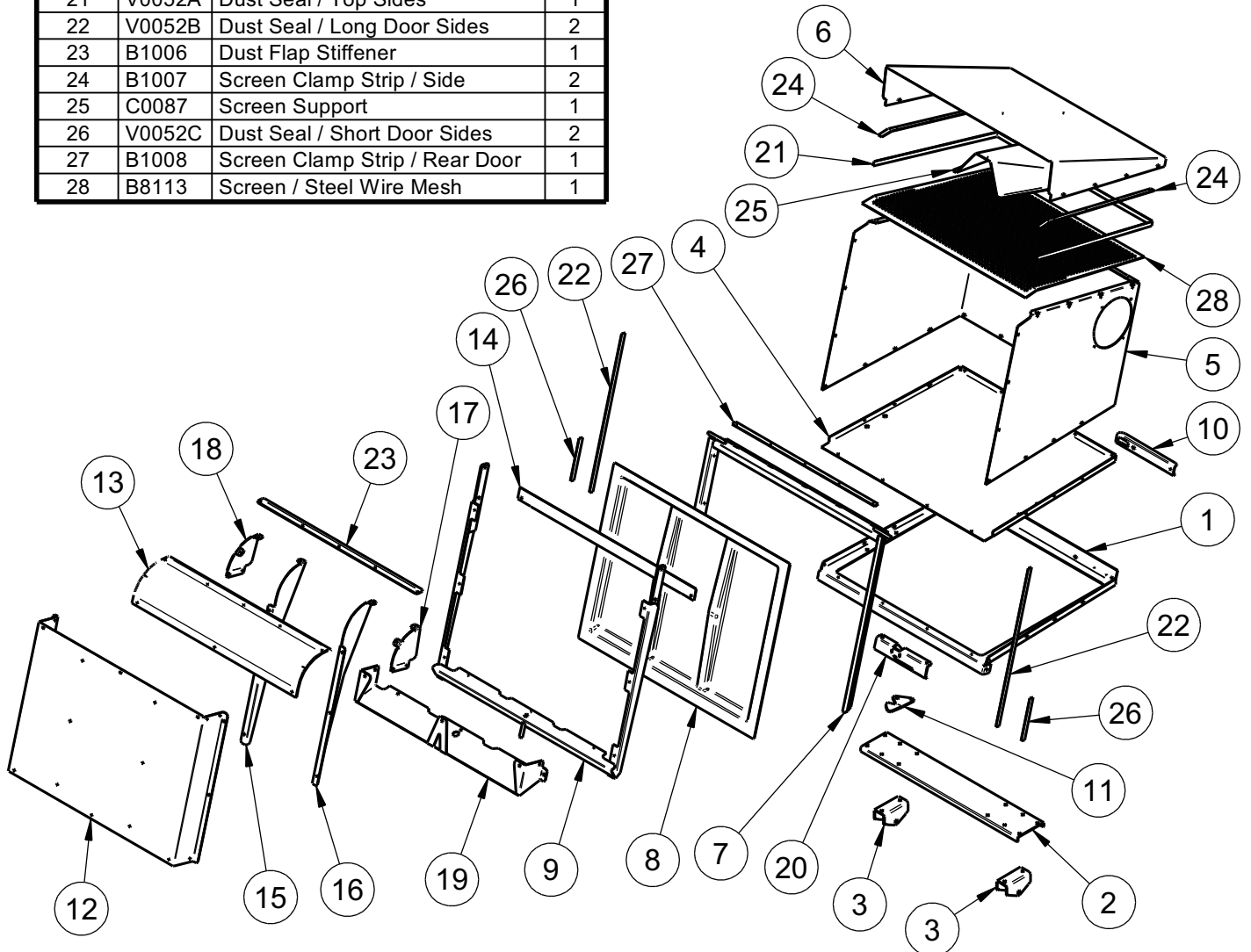

A2071 Mount Arm Assembly

Item #	Part #	Desc.	Qty.
1	A2040	Mount Arm Sub-Assy	1
2	J0009	Adjustable Handle 1/2"-13 x .59 Male	1
3	J0013	Nylon Flat Washer 1/2" x .750" OD Grade 6/6	2
4	J0020	Knob Plunger Pin 1/2"-13	1
5	K0027	Flat Washer 1/2" / .787 OD x .512 ID x .090 T	1

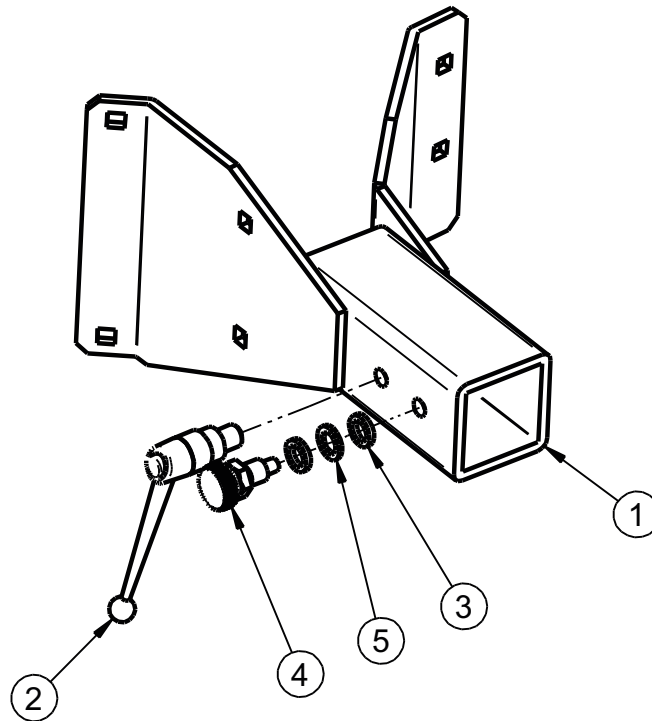

A2045 Boot Mounting Assembly

Item #	Part #	Desc.	Qty.
1	A2044	Deck Plate Assy	1
2	A2043	Boot Plate Assy	1
3	K1429	3/8"-16 x 6" HHCS GR5	1
4	K0042	Flat Washer 5/16" / .875 OD x .380 ID x .075 T	2
5	K2038	Ny-Flange Lock Nut 3/8"-16	1
6	J0017_1	Torsion Spring	1
7	K1146	5/16"-18 x 1-1/4" Carriage Bolt	2
8	K2516	Ny-Flange Lock Nut 5/16"-18	2
9	J0018	Wing Knob / 5/16-18 Thru Nut	2

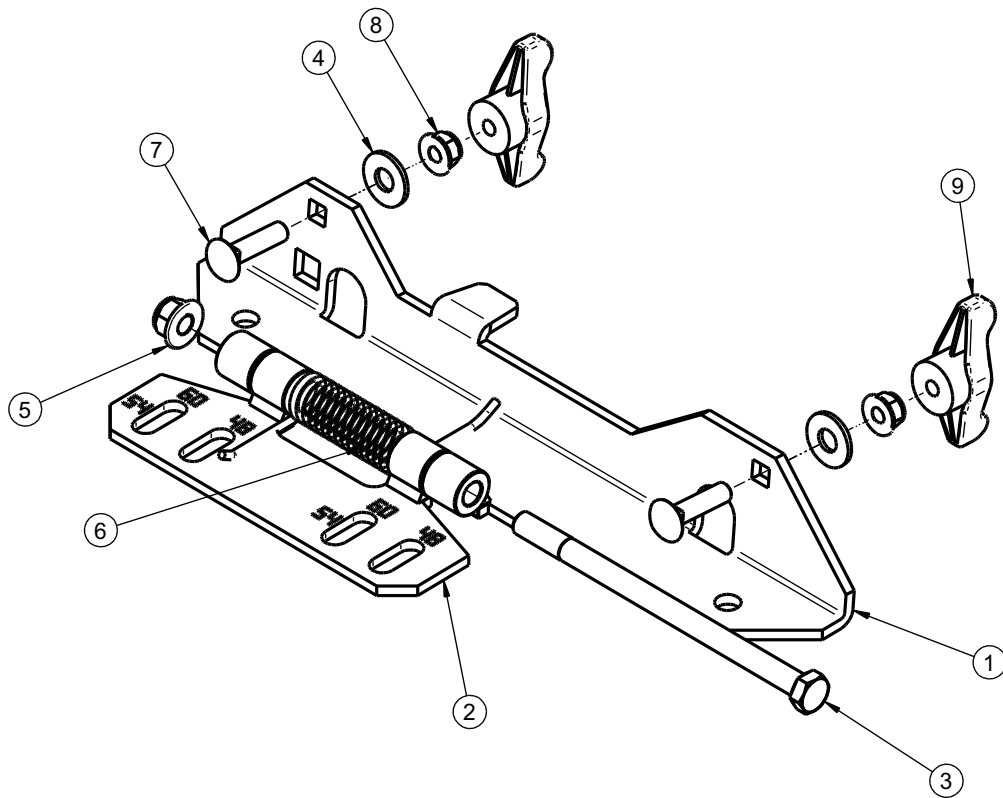

A2092 Idler Arm Assembly

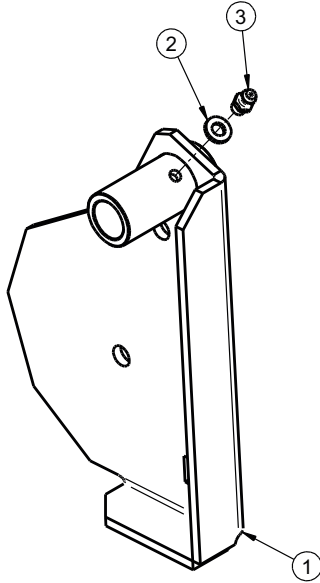

Item #	Part #	Desc.	Qty.
1	A2070_01	Idler Arm Weldment	1
2	K1467	Flat Washer M6 x 12mm OD	1
3	J0801	1/4"-28 Zirc Fitting	1

A2067_03 Idler Mount Assembly

Item #	Part #	Desc.	Qty.
1	B0958_03	Idler Mnt Pl	1
2	K2038	Ny-Flange Lock Nut 3/8"-16	3
3	K1463	Flat Washer .720 ID x 1.500 OD x .250 T	2
4	K1219	Jam Nut 3/8"-16	1
5	K1192	HHCS 3/8"-16 x 1-1/4" GR5	1
6	K0329	Nylock Nut 7/16"-14 GR8	1
7	M0003	Idler Pulley	1
8	K1462	HHCS 3/8"-16 x 1-3/4" GR8	1
9	K1464	Shoulder Bolt 7/16"-14 / Idler	1
10	J0024	Torsion Spring	1
11	A2092	Idler Arm Assy	1
12	B0974	Idler Base Plate	1
13	M0004	V Idler Pulley	1
14	K1211	3/8"-16 x 1-1/2" HHCS GR8	1
15	K0047	Flat Washer 3/8" / 1.00 OD x .446 ID x .075 T	1

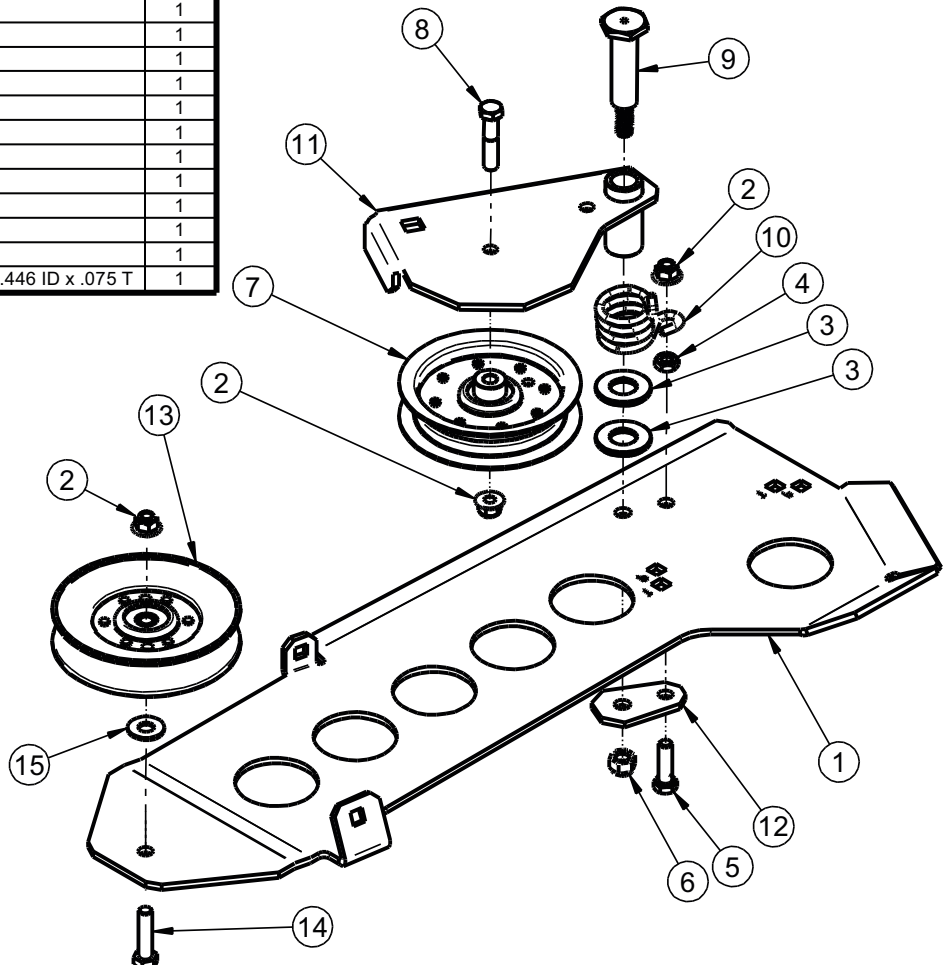

A2058 Gearbox Sub-Assembly

Item #	Part #	Desc.	Qty.
1	M0002	Gearbox	1
2	K0428	HHCS 5/16"-24 x 1" GR8	1
3	K0043	Lock Washer 5/16"	1
4	N0002	Pillow Block Bearing 7/8"	1
5	K0035	Set Screw 5/16"-18 x 1/4" Cup Point	1
6	J0272	Woodruff Key #9	1
7	A2048	Clutch Flange Assy	1

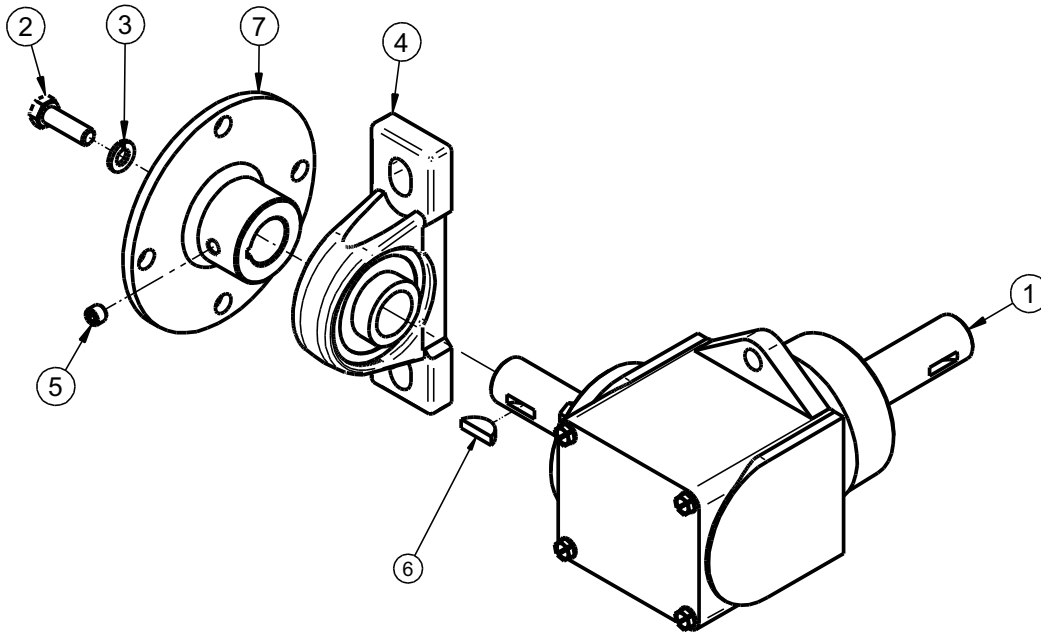

A2059_01 Clutch Sub-Assembly

Item #	Part #	Desc.	Qty.
1	M0001	Electric Clutch (Ogura 110 Ft-Lb Clutch/Brake)	1
2	S0007	Clutch Shaft	1
3	K0278	Double Indented Washer 7/16" / 1.375 OD x .440 ID x .179 T	1
4	K0140	Lock Washer 7/16" / High-Collar Helical Spring	1
5	K0359	HHCS / 7/16"-20 x 4.00" w/ Patch	1
6	M0309	A-Section Pulley / 4.75 OD	1
7	S0221	Eng. Pulley Bushing #27	1
8	K0076	Key 1/4" x 3/4" Long	1

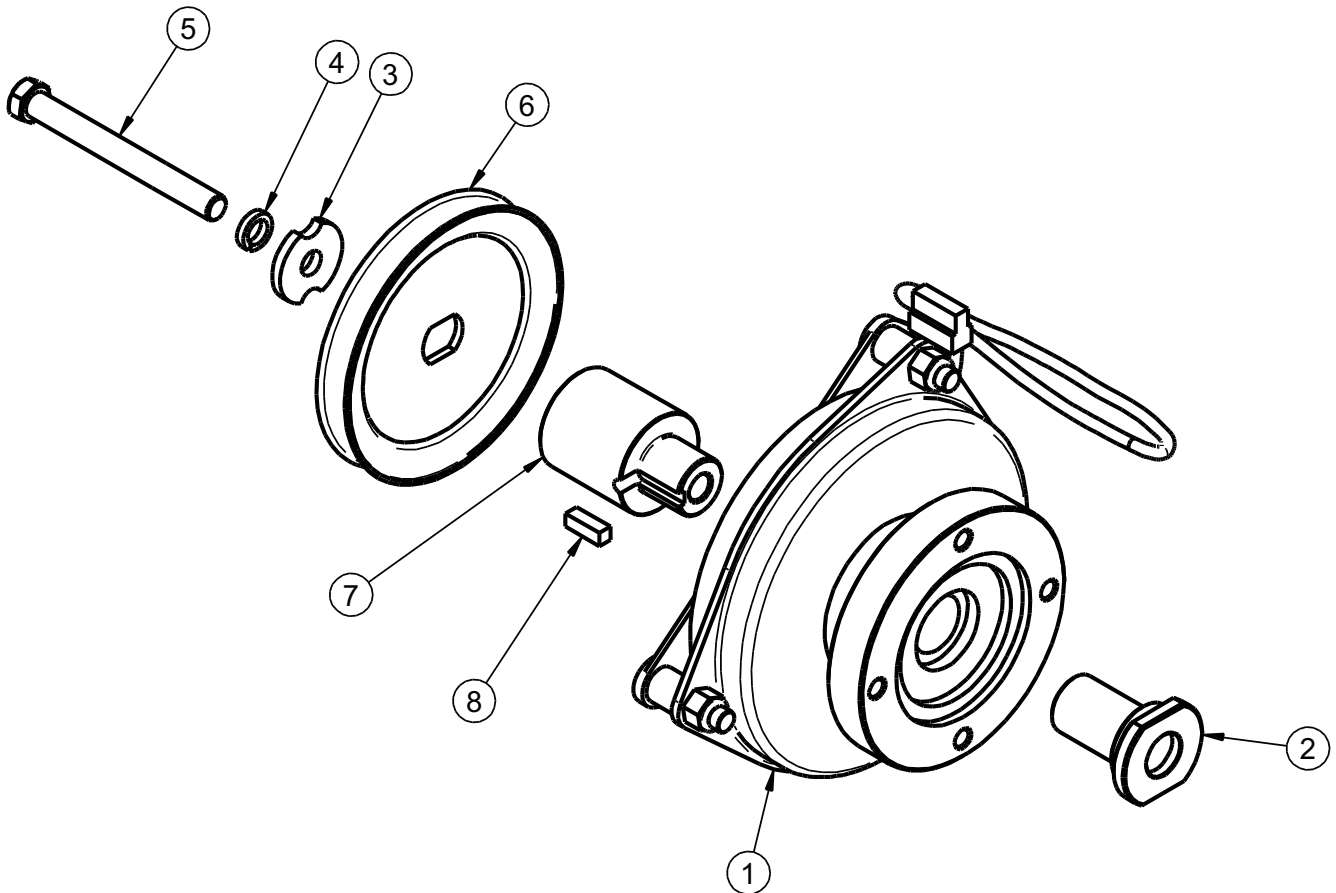

A2057_01 Drive Assembly Exploded Parts View

Item #	Part #	Desc.	Qty.
1	K0048	Lock Washer 3/8"	4
2	K0343	HHCS 3/8"-16 x 7/8" GR8	4
3	A2059_01	Clutch Sub-Assy (See Page 24)	1
4	A2058	Gearbox Sub-Assy (See Page 23)	1

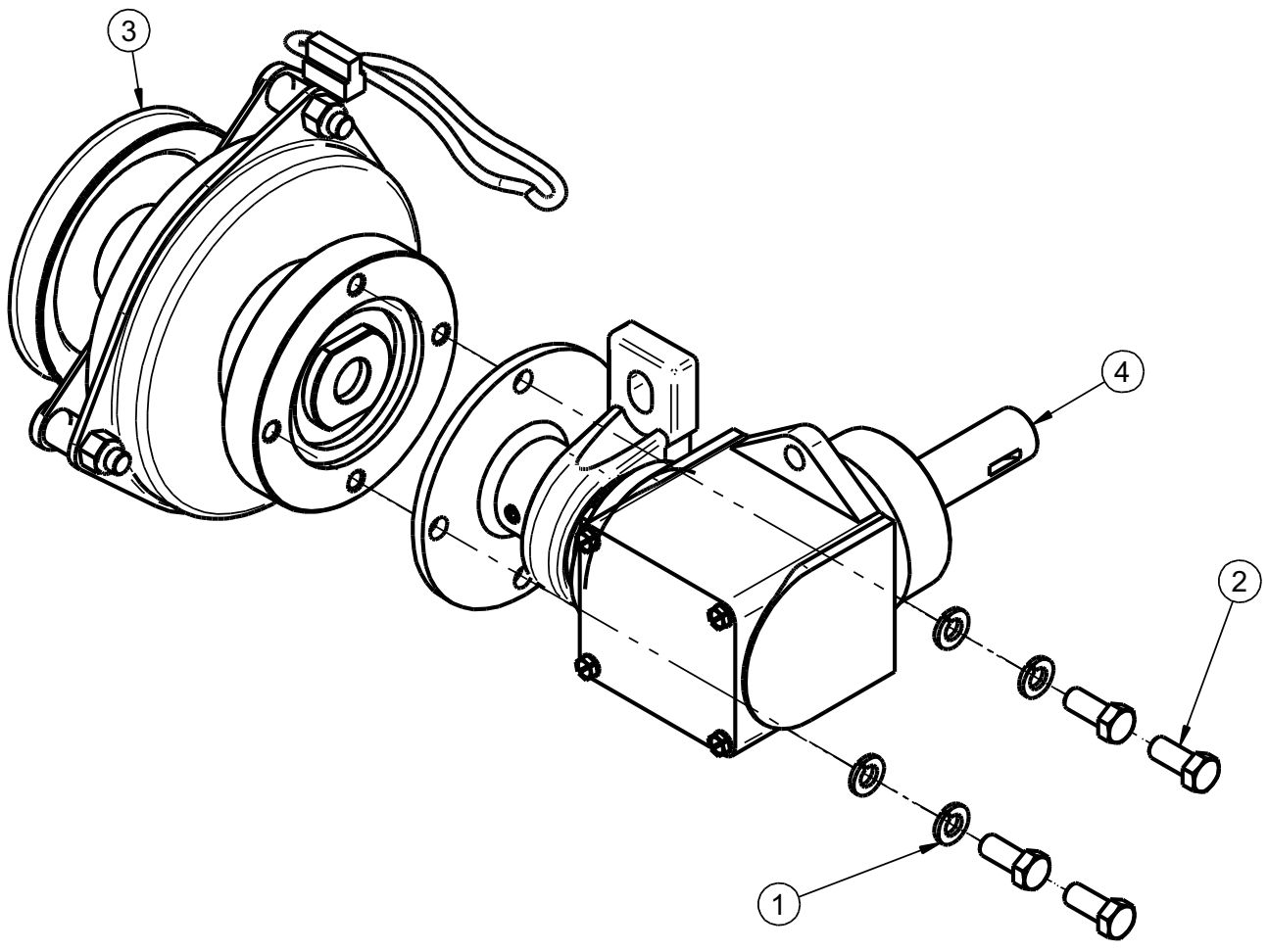

A2060_01 Mounted Drive Assembly

Item #	Part #	Desc.	Qty.
1	B0940	Spacer Plate	1
2	A2034	Drive Mnt Assy	1
3	K1191	HHCS 3/8"-16 x 1" GR5	2
4	K0048	Lock Washer 3/8"	2
5	K0055	Flat Washer 1/2" / 1.383 OD x .560 ID x .120 T	2
6	K0056	Lock Washer 1/2"	2
7	K1234	HHCS 1/2"-13 x 2"	2
8	A2057_01	Drive Assy (See page 25)	1

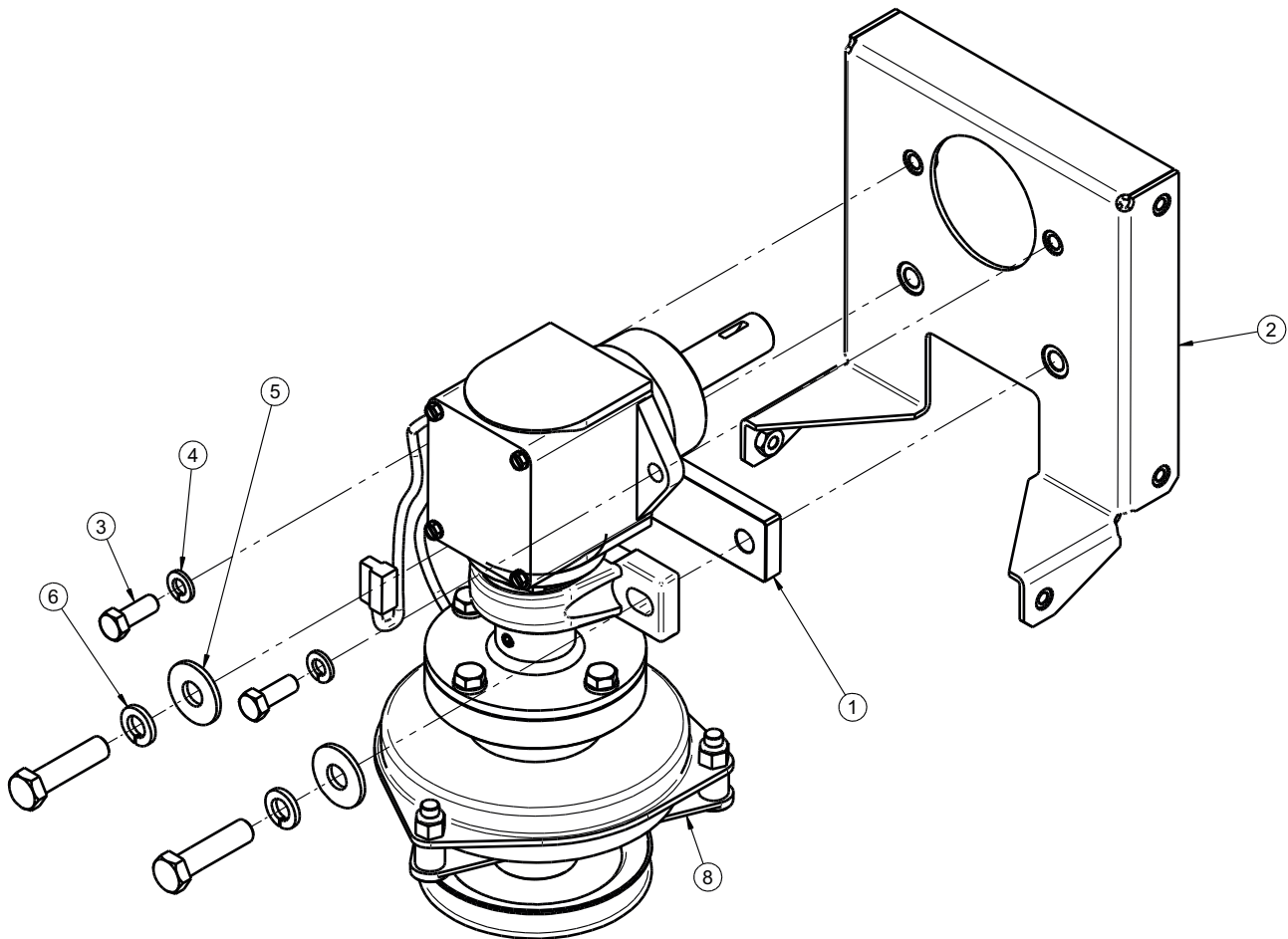

A2039_01 Base Drive Assembly

Item #	Part #	Desc.	Qty.
1	B0938	Drive Guard	1
2	A2032	Drive Arm Assy	1
3	A2035_01	Housing Mnt Assy	1
4	B0942_01	Anti-Rotation Brkt	1
5	K1153	HHCS 5/16"-18 x 3/4"	4
6	K0043	Lock Washer 5/16"	8
7	K0353	HWHTCS 1/4"-20 x 1/2"	2
8	K1154	HHCS 5/16"-18 x 1"	4
9	K2516	Ny-Flange Lock Nut 5/16"-18	2
10	A2060_01	Mounted Drive Assy	1
11	P0271	Quick Connect Wire Harness	1
12	K1142	5/16"-18 x 3/4" Carraige Bolt	2
13	K0509	3/8"-16 x 1-1/4" GR8 HHCS	1
14	K1215	Flange Nut 3/8"-16	1
15	K2038	Ny-Flange Lock Nut 3/8"-16	1
16	K0343	HHCS 3/8"-16 x 1-1/8" GR8	1
17	K1477	Flat Washer / 3/8" / .406 ID x .812 OD x .125 Thk	1
18	K1476	Reverse Lock Nut / 3/8"-16 Grade C	1

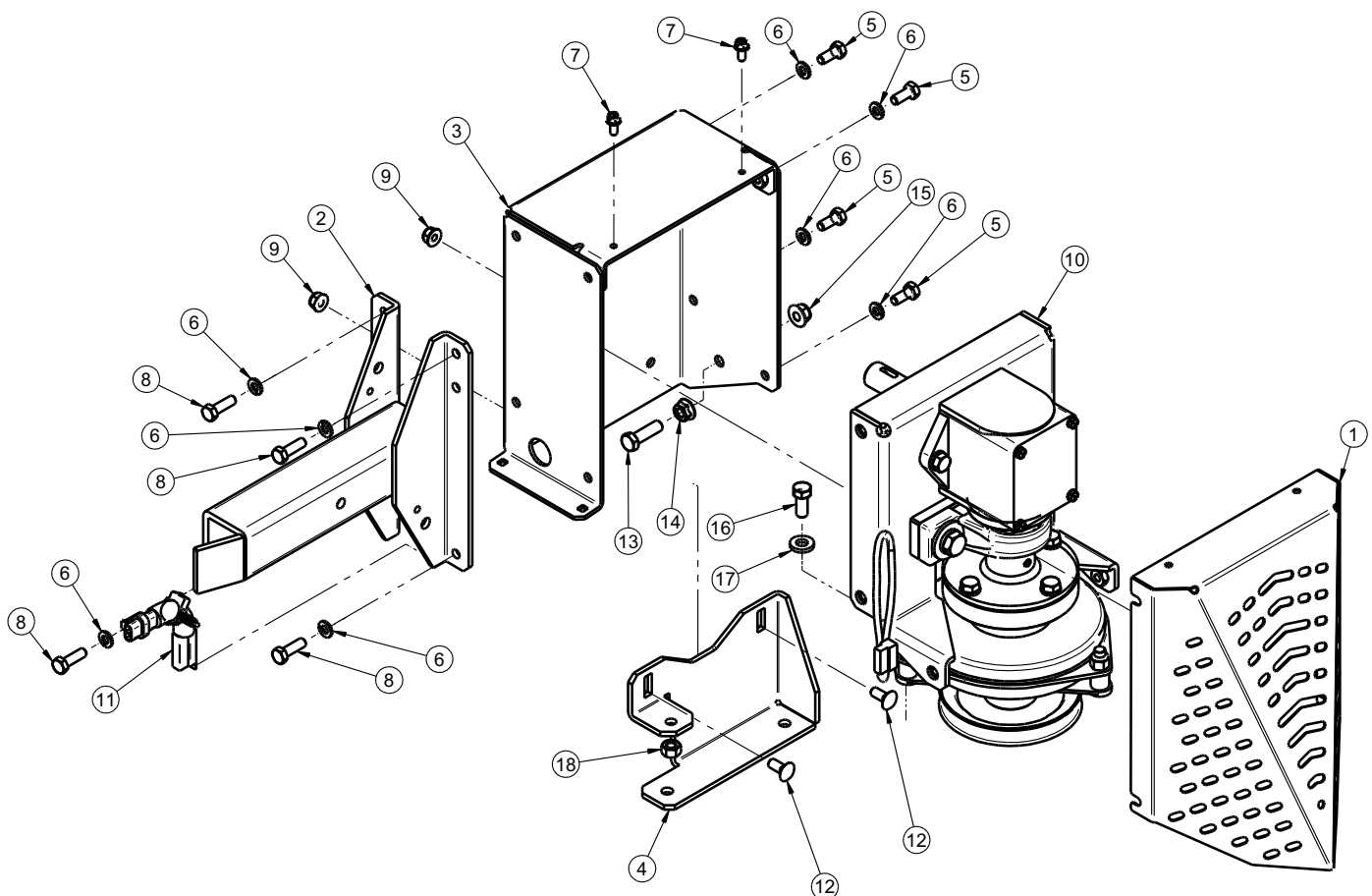

A2072 Drive Assembly / 5 Blade Impeller

Item #	Part #	Desc.	Qty.
1	A2039_01	Drive Assy / Base	1
2	K0044	I/T Tooth Lock Washer 5/16"	4
3	K1154	HHCS 5/16"-18 x 1"	4
4	A0644	5-Blade / Impeller	1
5	S0157	Taperlock Bushing 7/8"	1
6	K1225	HHCS 1/4"-20 X 1" GR8	2
7	K0284	Double Indented Washer 3/8" / 1.375 OD x .380 ID x .179 T	1
8	K1465	HHCS 5/16"-24 x 1-1/2" GR8	1
9	S0159	Spacer Bushing .938 OD x .325 ID x .375 T	2
10	E5007B	Blower Hsg Back	1
11	E5007F	Blower Hsg Front	1
12	K1125	HHCS 1/4"-20 X 1" GR2	7
13	K1126	Flange Nut 1/4"-20	7

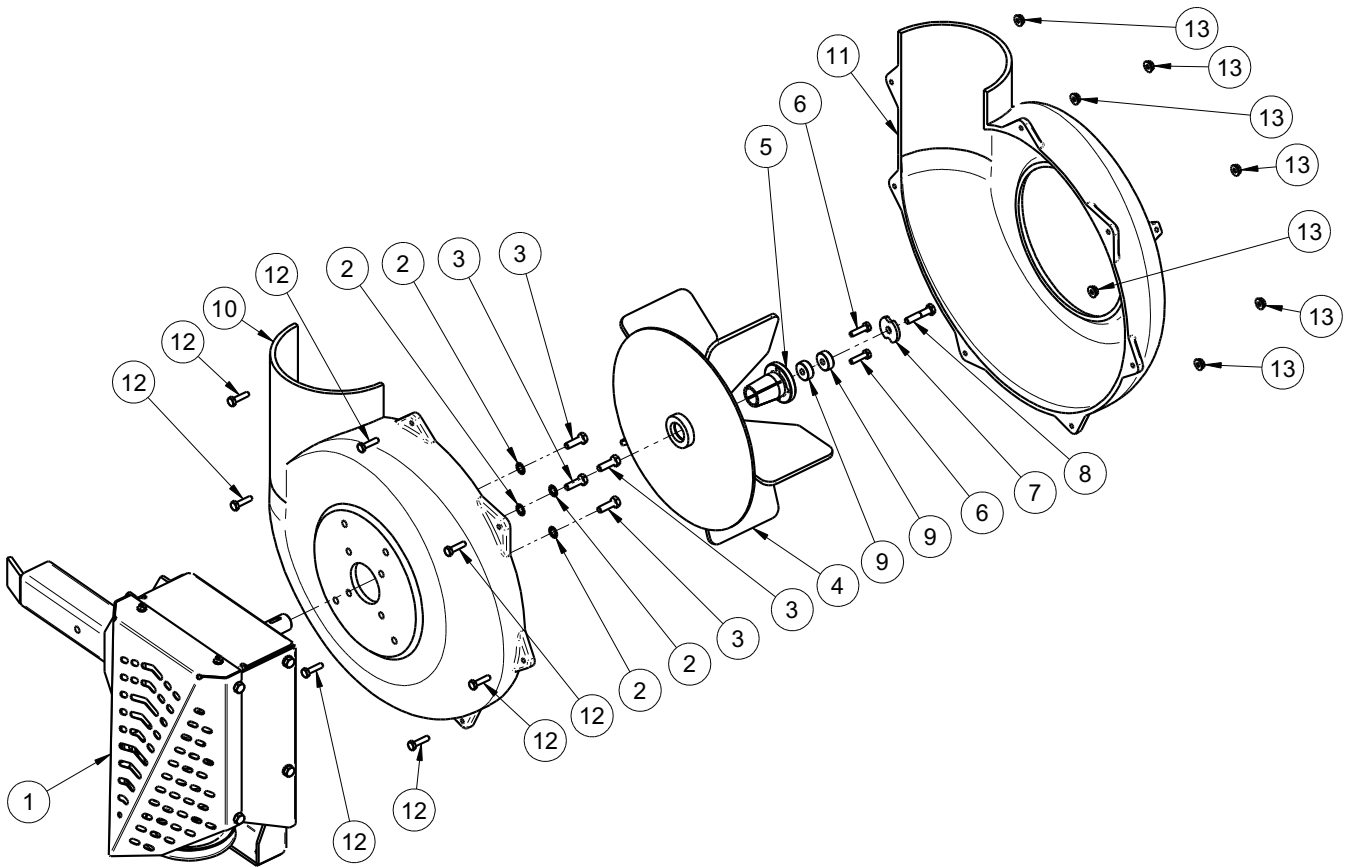

A2107 Latch Rod Assembly

Item #	Part #	Desc.	Qty.
1	B1000	Latch Rod / Hook Side	1
2	K0400	1/2" Flat Washer 1.084 OD x .528 ID x .120 T	2
3	J0303	Spring	1
4	K0086	Hair Pin Clip .125 OD x 2.50	1
5	A2106	Latch Rod Weldment	1

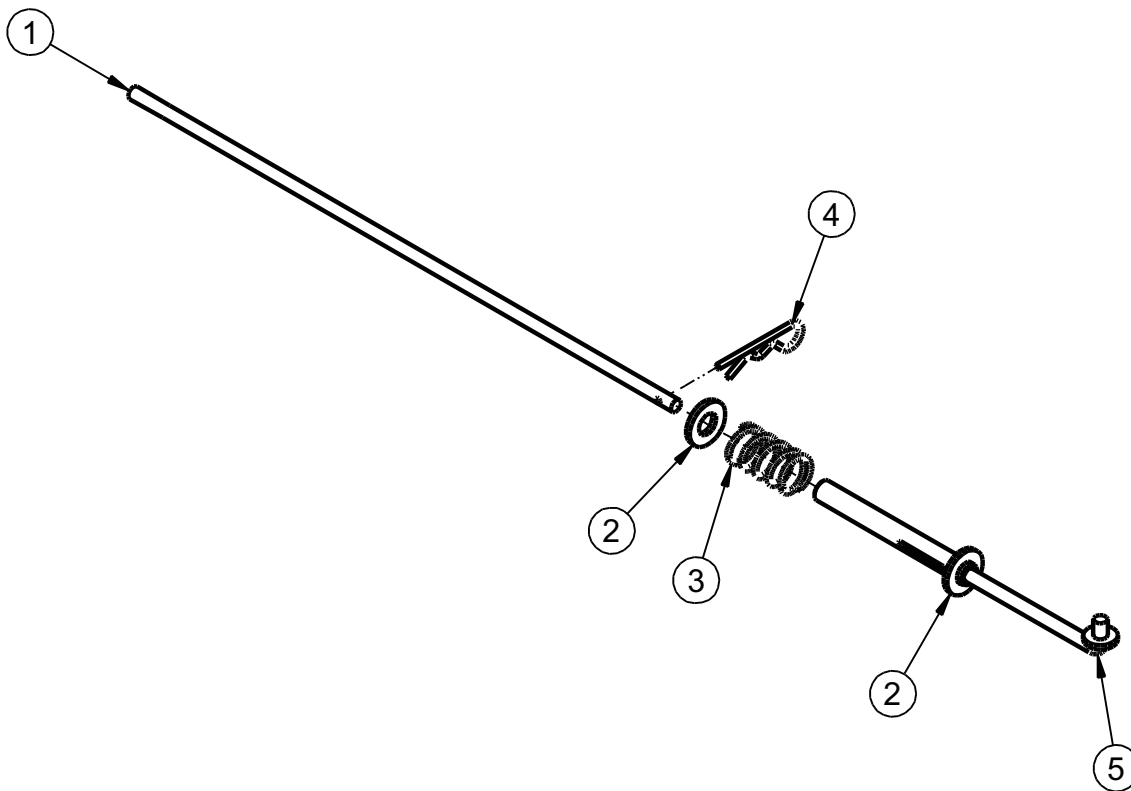



Unit Model #: 59A30051150 (21651217)

Mower & Type: Cub Cadet Pro Z 500, 700 & 900 Series

Mower Models: Pro Z 554L, Pro Z 560L, Pro Z 554S, Pro Z 560S, Pro Z 760L, Pro Z 760S, Pro Z 960L & Pro Z 960S

Owner's Manual: Q0508

Revision #:

Vac/Drive Type: P12 (12 Cu. Ft.) PTO-X Driven

Fits Year[s]: 2016 & Newer

I Series Mowers Require Weight Kit 59B30037150 (A1149) - Not Included On Pack

AZ085 Vac Kit

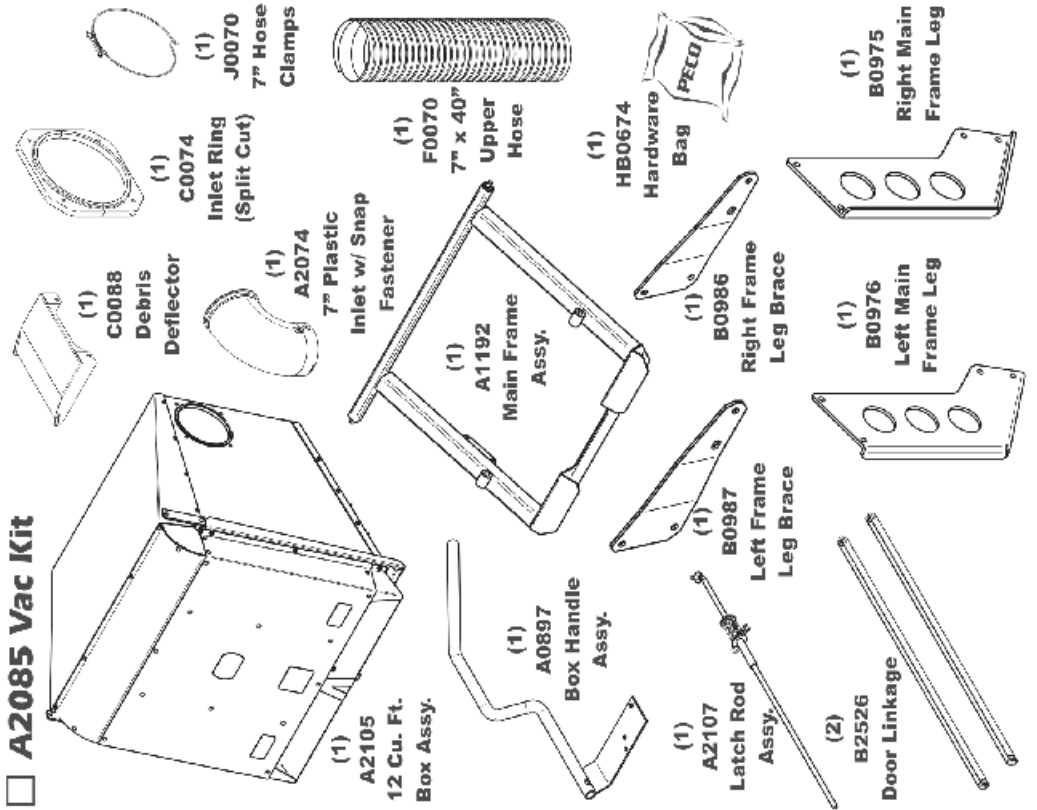

AZ080 Mount Kit

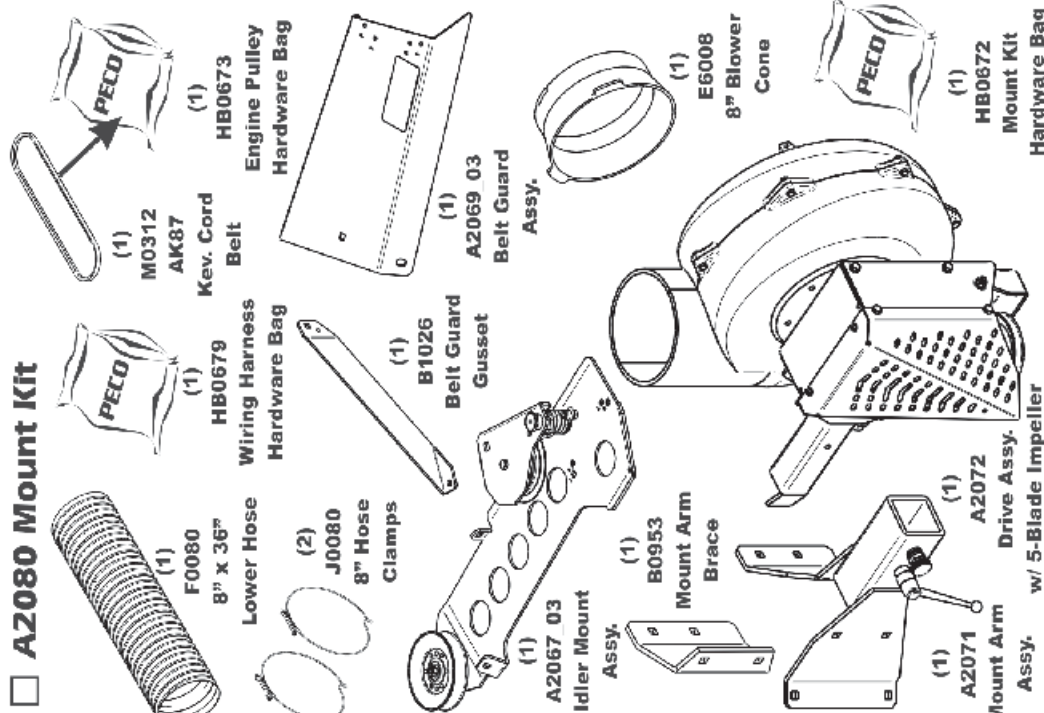

AZ066 Boot Kit

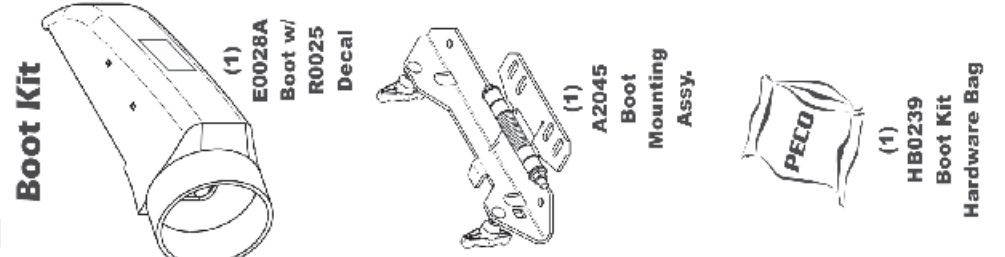

SAFETY DECALS

To promote safe operation, New PECO, Inc. supplies safety decals on all products manufactured. Damage can occur to safety decals either through shipment, use or reconditioning. Contact your local Service Center for replacement decals.



Part# R0023
Cub Cadet
Logo



Part# R0022
Designed & Built
In The USA



Part #: R2007
Danger - Never Use Hands



Part# R0026
Operation
Decal



Part #: R2008
Danger - Rotating Blades



Part #: R1054
Important - Hose Wear

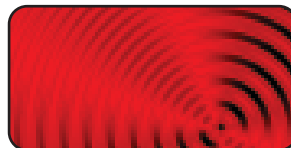
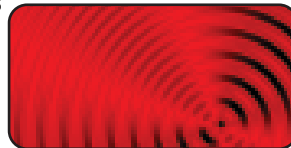

Part #: R1057 - (2)
Red Reflectors



Part #: R1069
Warning - Turn Off Blower



Part # R0024
Danger - Keep Hands
Clear



Part #: R1051
Warning - Hearing Protection



Part # R0025
Danger - Rotating
Blades

SECTION III OPERATING INSTRUCTIONS

3-1 General Safety

Only qualified people familiar with this operator's manual and the mower's operator's manual should operate this machine.

3-2 Operation And Tips On Mowing

- A. Perform BEFORE EACH USE the maintenance list in paragraph 4-1.
- B. Start mower.
- C. With the mower at high idle speed, engage the mower deck.
- D. While seated in the operator's seat, move Bagger PTO switch to the on position. With the PTO assembly engaged, you can proceed to operate the control levers of the mower.

NOTE: If the collection system does not appear to be collecting the grass clippings, disengage the deck and PTO assembly (Section 3-3), then, engage the parking brake and turn the mower off. Check upper and lower hoses for any clogs.

To obtain the maximum effectiveness from your collection system, the tips listed below should be followed:

- * Watch your speed- Normal conditions will allow a speed of up to approximately 4 mph, but thick, heavy damp conditions will require reduced ground speed.
- * Mow with sharp blades- A sharp blade cuts cleaner.
- * Wet grass and leaves will decrease effectiveness and will increase horsepower requirements.
- * Mow at higher cutting heights- Remove and mulch no more than 2" of grass length with each mowing. (Experts recommend not cutting off more than 1/3 of the grass blade length at any given time.)
- * Mow twice, at different height settings, (high, then low), if grass is extra tall.
- * Remember that horsepower requirements will vary with the mowing conditions such as type and height of turf grass, moisture content, amount of leaves, whether the terrain is flat or hilly, etc.

3-3 Disengagement Of The PTO Assembly

- A. To disengage the PTO assembly, move Bagger PTO switch to the off position.

WARNING: The PTO assembly blades will continue to spin. DO NOT TOUCH the PTO assembly, pulleys, or the belt until the tractor is turned off. DO NOT adjust the belt tension until the mower is turned off. Refer to the Belt Installation section of the manual.

3-4 Unloading The Collection System

- A. Stop the forward movement of the mower, engage the parking brake.
- B. Disengage the mower deck.
- C. Disengage the blower.
- D. Verify that the dump area is clear.
- E. Push the dump handle, on the left of the operator, away from the unit. While holding the handle pushed away, move the handle upward. The container door will swing upward and the container will rotate downward. The container will release its contents.
- F. Once the contents of the container have fallen out, the container is ready to move back into its normal operating position. Pull the handle downward until positive latching is achieved.

SECTION IV MAINTENANCE

4-1 Maintenance Checklist

Before each use:

1. Check blades and spindles to be sure that no foreign objects, such as wire or steel strapping bands, are wrapped around them.
2. Inspect blades for wear. Replace if necessary. If it is necessary to sharpen the blades, remove the blades from the spindles before sharpening. DO NOT sharpen blades while still attached to the mower.

3. Make sure all shields are in place and in good condition. Repair or replace any missing or damaged shields.
4. Perform lubrication per paragraph 4-2.
5. Listen for abnormal sounds, which might indicate loose parts, damaged bearings, or other damage. Correct any deficiency before continuing operation.
6. With the engine off check the belt tension and inspect the pulley belt for cracks or tears.
7. Check for wear or deterioration of the upper or lower hoses. If there are any portions of the hose that have been torn or worn through, replace immediately.

After Each Use:

1. Clean all debris from machine especially from the container, underneath the belt shields, and safety decals. Replace any missing or illegible decals.
2. Inspect the unit for worn or damaged components. Repair or replace before the next use. Any replacement component installed during repair shall include the component's current safety decal specified by the manufacturers to be affixed to the component.
3. Check belt for proper tension.

4-2 Lubrication

Gearbox:

1. Every 20 hours of use: Check oil levels in gearbox.
2. First 60 hours of use: Change oil.
3. Every 100 hours of use: Change oil.

NOTE: Oil in gearbox should cover the gears. If not, drain the gearbox and fill using an 80W-90 gear oil. The gearbox ships with 6.0 oz. of oil, but we recommend replacing with a measured 5.5 oz. to fill the gearbox. **DO NOT OVERFILL!**

Blower Assembly:

1. Every 100 hours grease idler arm grease fitting with white lithium grease.

SECTION V PARTS AND SERVICE

5-1 Parts And Service Information

Collection system owners should record the name and telephone number of their Service Center. Your Service Center will be happy to supply replacement parts, accessories, and do any service or repairs to your collection system. If for any reason your Service Center is unable to service your collection system or supply replacement parts, contact New PECO, Inc. and include the following information on the chart below.

DOCUMENT THE FOLLOWING INFORMATION FOR FUTURE REFERENCE

MODEL: 59A30051150
SERIAL: _____ <small>R0019</small>

Date of Purchase: _____

Dealer/Distributor Name: _____

Address: _____ **State:** _____ **Zip:** _____

Phone Number: _____

TORQUE SPECIFICATIONS

Proper torque for American fasteners used on PECO equipment.
Recommended Torque in Foot Pounds (Newton Meters).*

AMERICAN Bolt Head Markings

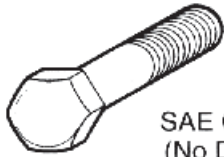

SAE Grade 2
(No Dashes)

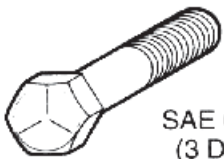

SAE Grade 5
(3 Dashes)

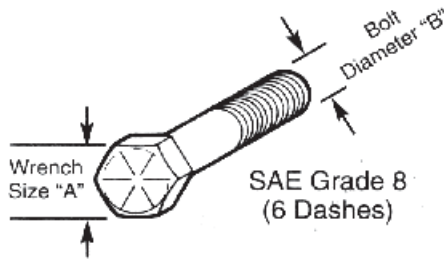

SAE Grade 8
(6 Dashes)

WRENCH SIZE (IN.) "A"	BOLT DIAMETER (IN.) "B" AND THREAD SIZE	SAE GRADE 2	SAE GRADE 5	SAE GRADE 8
7/16	1/4 - 20 UNC	6 (7)	8 (11)	12 (16)
7/16	1/4 - 28 UNF	6 (8)	10 (13)	14 (18)
1/2	5/16 - 18 UNC	11 (15)	17 (23)	25 (33)
1/2	5/16 - 24 UNF	13 (17)	19 (26)	27 (37)
9/16	3/8 - 16 UNC	20 (27)	31 (42)	44 (60)
9/16	3/8 - 24 UNF	23 (31)	35 (47)	49 (66)
5/8	7/16 - 14 UNC	32 (43)	49 (66)	70 (95)
5/8	7/16 - 20 UNF	36 (49)	55 (75)	78 (106)
3/4	1/2 - 13 UNC	49 (66)	76 (103)	106 (144)
3/4	1/2 - 20 UNF	55 (75)	85 (115)	120 (163)
7/8	9/16 - 12 UNC	70 (95)	109 (148)	153 (207)
7/8	9/16 - 18 UNF	79 (107)	122 (165)	172 (233)
15/16	5/8 - 11 UNC	97 (131)	150 (203)	212 (287)
15/16	5/8 - 18 UNF	110 (149)	170 (230)	240 (325)
1-1/8	3/4 - 10 UNC	144 (195)	266 (360)	376 (509)
1-1/8	3/4 - 16 UNF	192 (260)	297 (402)	420 (569)
1-5/16	7/8 - 9 UNC	166 (225)	430 (583)	606 (821)
1-5/16	7/8 - 14 UNF	184 (249)	474 (642)	668 (905)
1-1/2	1 - 8 UNC	250 (339)	644 (873)	909 (1232)
1-1/2	1 - 12 UNF	274 (371)	705 (955)	995 (1348)
1-1/2	1 - 14 UNF	280 (379)	721 (977)	1019 (1381)
1-11/16	1-1/8 - 7 UNC	354 (480)	795 (1077)	1288(1745)
1-11/16	1-1/8 - 12 UNF	397 (538)	890 (1206)	1444 (1957)
1-7/8	1-1/4 - 7 UNC	500 (678)	1120 (1518)	1817 (2462)
1-7/8	1-1/4 - 12 UNF	553 (749)	1241 (1682)	2013 (2728)
2-1/16	1-3/8 - 6 UNC	655 (887)	1470 (1992)	2382 (3228)
2-1/16	1-3/8 - 12 UNF	746 (1011)	1672 (2266)	2712 (3675)
2-1/4	1-1/2 - 6 UNC	870 (1179)	1950 (2642)	3161 (4283)
2-1/4	1-1/2 - 12 UNF	979 (1327)	2194 (2973)	3557 (4820)

METRIC

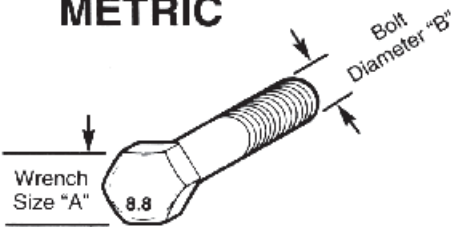

Numbers appearing on bolt heads indicate ASTM class.

Proper torque for metric fasteners used on PECO equipment.
Recommended torque in foot pounds (newton Meters).*

WRENCH SIZE (mm) "A"	BOLT DIA. (mm) "B"	ASTM 4.6	ASTM 8.8	ASTM 9.8	ASTM 10.9
8	5	1.8 (2.4)		5.1 (6.9)	6.5 (8.8)
10	6	3 (4)		8.7 (12)	11.1 (15)
13	8	7.3 (10)		21.1 (29)	27 (37)
16	10	14.5 (20)		42 (57)	53 (72)
18	12	25 (34)	74 (100)	73 (99)	93 (126)
21	14	40 (54)	118 (160)	116 (157)	148 (201)
24	16	62 (84)	167 (226)	181 (245)	230 (312)
30	20	122 (165)	325 (440)		449 (608)
33	22		443 (600)		611 (828)
36	24	211 (286)	563 (763)		778 (1054)
41	27		821 (1112)		1138 (1542)
46	30	418 (568)	1119 (1516)		1547 (2096)

*Use 75% of the specified torque value for plated fasteners. Use 85% of the specified torque values for lubricated fasteners.

Troubleshooting

Collection System Performance

Problem	Possible Cause	Corrective Action
Abnormal Vibration	<ul style="list-style-type: none"> • Cutting blades are bent or unbalanced • Loose blower pulley or pulley assembly • Impeller blade out of balance 	<ul style="list-style-type: none"> • Install new cutting blade • Tighten the pulley • Contact dealer to replace
Reduced collection system performance	<ul style="list-style-type: none"> • Low engine speed • Plugged screen • Loose belt • Full collection bags 	<ul style="list-style-type: none"> • Always operate collection system at full throttle • Remove debris, leaves, or grass clippings from the screen • Replace/tighten belt • Empty the collection bags
Blower and hoses plugging too frequently	<ul style="list-style-type: none"> • Collection bags are too full • Low engine speed • Grass is too wet • Grass is too long • Ground speed is too fast • Worn belt • Loose belt 	<ul style="list-style-type: none"> • Dump more frequently • Always operate collection system at full throttle • Cut grass when it is dry • Cut the grass several times • Drive slower at full throttle • Replace belt • Adjust the pulley and tighten belts
Debris blowout	<ul style="list-style-type: none"> • Collection bags are too full • Plug/clog in the collection system • Ground speed is too fast 	<ul style="list-style-type: none"> • Dump more frequently • Clean the collection system • Drive more slowly at full throttle
Impeller doesn't rotate freely	<ul style="list-style-type: none"> • Plug in the blower housing • Worn impeller blade • Shaft bearings bad/failing 	<ul style="list-style-type: none"> • Clean the blower housing • Contact dealer to replace • Contact dealer to replace

Notes

Cub Cadet®

Cub Cadet LLC
P.O. Box 361131
Cleveland, Ohio 44136-0019
Phone: 1-877-282-8684

MTD Products Limited
Kitchener, ON N2G 4J1
1-800-668-1238