



# PTO DRIVEN - GRASS COLLECTION SYSTEM

Pro 2 Bagger Model # **38120905**

Pro 3 Bagger Model # **38131508**

**Dixie Chopper  
BlackHawk / HP**

**&**

**Jacobsen  
ZT400 & ZT600**

Model Year: **2016 - Newer**

Deck Sizes: **48", 54" & 60"**



## OPERATOR'S MANUAL

**ASSEMBLY • OPERATION • MAINTENANCE**

# GRASS COLLECTION SYSTEM

## TABLE OF CONTENTS

SECTION	PAGE	SECTION	PAGE
Safety	2	Length of Hose Adjustment	16
Safety Alert Symbols	3	Upper Hose Installation	16
Warranty	4	Lower Hose To Blower Cone Installation	16
I INTRODUCTION AND DESCRIPTION	5	Lower Hose To Boot Installation	16
Introduction	5	Bag Assy	17
Description	5	Bag Assy Installation	17
II INSTALLATION FOR USE	6	Impeller Blade Removal/Replacement	18
Preparation Of Mower	6	Weight Kit Installation	19
Rear Mount Kit Assy Installation	7	Exploded Views & Parts List	20-23
PTO Mount Assy Installation	8	Overall Parts List	24-25
PTO Assy & Handle Assy Installation	9	Safety Decals	26
Belt Installation & Adjustment	10	III OPERATING INSTRUCTIONS	27
Cam Assy Adjustment	11	General Safety	27
Blower Cone Installation	11	Operation & Tips On Mowing	27
Boot Kit Installation	12	Disengagement Of The PTO Assembly	27
Lower Mount Tube Installation	13	Unloading The Collection System	27
Upper Frame Assy Installation	13	IV MAINTENANCE	27-28
Top Assy To Upper Frame Assy Installation	14	Maintenance Checklist	27
Inlet Installation	14	Lubrication	28
Hinge Kit Assy Installation	15	V PARTS AND SERVICE	28
Even Bag Fill Adjustment	15	Parts And Service Information	28
		Torque Specifications	29
		Troubleshooting	30

## SAFETY

1. Read the operator's manual carefully and familiarize yourself with the proper use of your attachment. Do not allow anyone who is not acquainted with the Safety Instructions to use your attachment.
2. Know the controls and how to stop them quickly. **READ THE OPERATOR'S MANUAL!**
3. Do not allow children to operate the machine. Do not allow adults to operate it without proper instruction.
4. Be especially watchful of children and pets entering into the area while operating.
5. Keep your eyes and mind on your machine while mowing or operating your attachment. Don't let others distract you.
6. Do not attempt to operate your machine when not in the driver's seat.
7. Always shut off blades and engine when emptying the container.
8. Stop machine, shut off deck attachment, set parking brake, shut off engine and remove ignition key before removing clogs, removing or replacing hose, boot, blower cone, or performing any maintenance.
9. Mow across the face of slopes (not more than 10 degrees); never up and down the face.
10. It is recommended that the container be emptied when half full while operating on slopes. Start mowing on slopes when the container is empty.
11. Inspect your lawn and remove any foreign objects before mowing. Never deliberately run the mower across any foreign object.
12. Wear hearing protection.
13. Wear eye protection to prevent debris from getting into your eyes.

# SAFETY

**WARNING!** NEVER operate the mower unless the discharge guard and either the deflector assembly or the vacuum collector adapter are fastened securely in place.

**WARNING!** Do not work around the mower deck boot or the blower area until you are certain that the mower blades and the blower impeller have stopped rotating.

**WARNING!** To avoid serious injury, perform maintenance on the vacuum collector; **ONLY AFTER STOPPING THE MOWER'S ENGINE AND WAITING FOR ALL MOVING PARTS TO COME TO A COMPLETE STOP.** Set the parking brake. Always remove the ignition key before beginning maintenance.

**WARNING!** For your own personal safety, **ALWAYS mow ACROSS the face of slopes and NEVER UP and DOWN the face. NEVER attempt to mow excessively steep slopes, and use caution when turning on any slope.**

## Safety Alert Symbol



This Safety Alert Symbol means: **“ATTENTION! BECOME ALERT! YOUR SAFETY IS INVOLVED!”**

This symbol is used to call attention to safety precautions that should be followed by the operator to avoid accidents. When you see this symbol, carefully read the message that follows and heed its advice. Failure to comply with safety precautions could result in death or serious bodily injury.

## Safety Signs

The signal words **DANGER**, **WARNING**, and **CAUTION** are used on the equipment safety signs. These words are intended to alert the viewer to the existence and the degree of hazard seriousness.



White letters on **RED**

This signal word indicates a potentially hazardous situation which, if not avoided, will result in death or serious injury.



Black letters on **ORANGE**

This signal word indicates a potentially hazardous situation which, if not avoided, could result in death or serious injury.

It may also be used to alert against unsafe practices.



Black letters on **YELLOW**

This signal word indicates a potentially hazardous situation which, if not avoided, will result in minor or moderate injury.

It may also be used to alert against unsafe practices.

# PECO LIMITED WARRANTY FOR NEW PRODUCTS

## A. WHAT IS UNDER WARRANTY?

PECO extends the following warranties to the original purchaser of each new PECO consumer product subject to the following limitations.

- 1. PRODUCT WARRANTY:** Any part of any consumer product, which is defective in material or workmanship as delivered to the purchaser will be repaired or replaced, as PECO elects, without charge for parts or labor, if the defect appears within 12 months from the date of delivery of the product to the original purchaser. ALL DEFECTIVE PARTS MUST BE RETURNED TO PECO FOR INSPECTION TO DETERMINE VALIDITY OF WARRANTY CLAIMS. Freight and mailing will be borne by the customer.
- 2. PARTS REPLACED DURING WARRANTY:** Any new PECO part which is furnished in performance of this warranty and is defective in material or workmanship as delivered to the purchaser will be repaired or replaced, before the expiration of the original warranty period, whichever is later.
- 3. COMMERCIAL USE:** Products put to personal use around a single household or residence is considered 'Residential'; Products put to any business use (agricultural, commercial, or industrial) or used at multiple locations is considered 'Commercial.' Products designated as 'Commercial' are warrantied for 12 months from the date of delivery of the product to the original purchaser when used for in commercial applications. Products designated as 'Residential' are warrantied for 90 days from the date of delivery of the product to the original purchaser when in commercial applications.

## B. SECURING WARRANTY ADJUSTMENTS

Call PECO for Return Authorization. Damaged or broken parts other than engines or batteries, must be returned to New PECO, Inc. at 10 Walden Drive, Arden, NC 28704 before any warranty adjustment can be authorized. At the time of requesting warranty adjustment, the purchaser must present evidence of the date of delivery of the product. The purchaser shall pay any charge for the product to and from Arden, NC.

## C. ITEMS NOT COVERED BY PECO WARRANTY

Engines and batteries attached to PECO products are covered under a separate warranty by the respective manufacturer.

## D. UNAPPROVED ALTERATION OR MODIFICATION

All obligations of New PECO, Inc. under this warranty shall be terminated if products are altered or modified in ways not approved by New PECO, Inc.

## E. ACCIDENTS AND NORMAL MAINTENANCE

The warranty covers only defective material and workmanship. It does not cover depreciation or damage caused by normal wear, accident, improper use or abuse of products. The cost of normal maintenance and normal replacement of service items such as belts, cutting blades, hoses, etc., which are not defective shall be paid for by the purchaser.

## F. NO REPRESENTATIONS ADDITIONAL WARRANTIES, DISCLAIMER

Neither New PECO, Inc. nor any company affiliated with it makes any warranties, representations or promises as to the quality of performance of its products other than those set forth herein. Except as described above, New PECO, Inc. makes no other warranties AND SPECIFICALLY DISCLAIMS ANY AND ALL IMPLIED WARRANTIES OF FITNESS AND MERCHANTABILITY.

## G. PRODUCTS USED FOR RENTAL OR LEASE PURPOSES ARE WARRANTIED FOR 45 DAYS FROM DATE OF ORIGINAL SALE ONLY

## H. REMEDIED EXCLUSIVE

The only remedies the purchaser has in connection with the breach or performance of any warranty on New PECO, Inc. consumer products are set forth above. In no event will PECO be liable for special incidental or consequential damages.

### 1. NO SERVICE CENTER WARRANTY

The selling Service Center makes no warranty on his own on any item warrantied by New PECO, Inc. unless he delivers to purchaser a separate written warranty certificate specifically warranting the item. The dealer has no authority to make any representation or promise on behalf of PECO or to modify the terms of this warranty in any way.

# Section I - INTRODUCTION AND DESCRIPTION

## Introduction

We are pleased to have you as a PECO customer. Your collection system has been designed to give you a low maintenance, simple, and effective way to collect the grass clippings from your mower. The manuals are provided to give you the necessary instructions to properly mount, operate and maintain the collection system on your mower. Please read this manual thoroughly. Understand what each control is for and how to use it. Observe all safety decal precautions on the machine and noted throughout the manual.

**NOTE:** All references made to right, left, front, rear, top or bottom are as viewed from the normal operator's position on the mower.

## Description

The grass collection system is designed for turf maintenance where there is a need to collect the grass clippings as the mower cuts the turf. It is also used for picking up leaves in pre-season and post-season clean-up. The blower, mounted on the right side of the unit, uses a belt and gearbox system from the engine PTO shaft. Drive train protection comes through belt slippage. The blower draws grass clippings from the discharge area of the cutting deck back to the collection bags at the rear portion of the mower frame. The operator can engage the blower with a push of the over-center linkage on the right side of the unit. Once the bags are full with clippings, they can be easily released for dumping.



## Section II - INSTALLATION FOR USE

### Preparation Of Mower

**NOTE:** The mower deck PTO belt must be removed from the electric clutch before continuing with the installation. Refer to your mower's owner's manual for instructions on PTO belt removal.

From the underside of the engine, disconnect the wiring harness attached to the electric clutch. Remove the bolt and electric clutch from the mower. Refer to Figure A.

Figure A

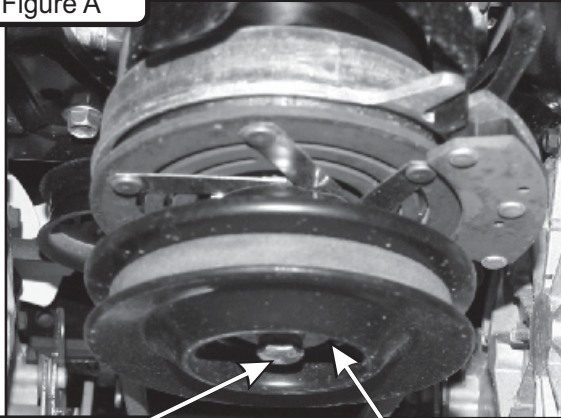

Remove Bolt

D-Drive Spacer

Upon removal of clutch determine if your mower is equipped with a D-drive spacer. If so, then proceed to Figure B. If your mower is equipped with bolt, fender and lock washer without D-drive spacer proceed to Figure C. Remove the D-drive spacer using an arbor press or equivalent. On removal, adjacent bearing OUTER race must be supported or bearing damage may occur. Refer to Figure B.

Figure B

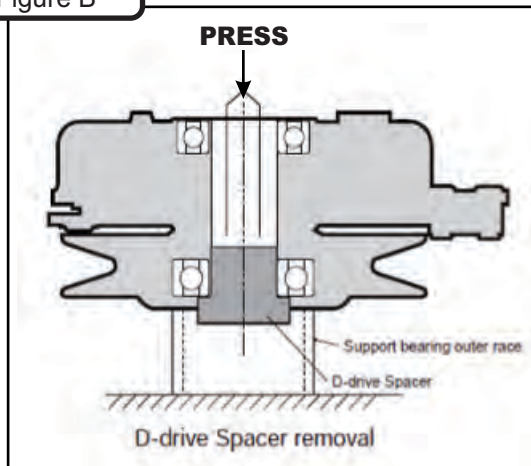
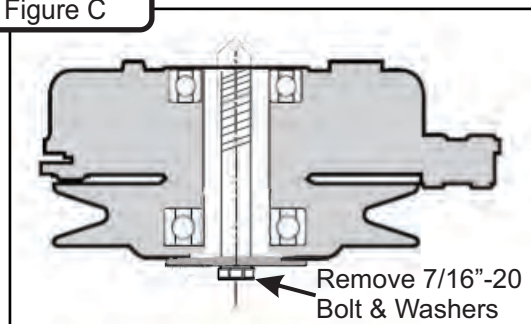
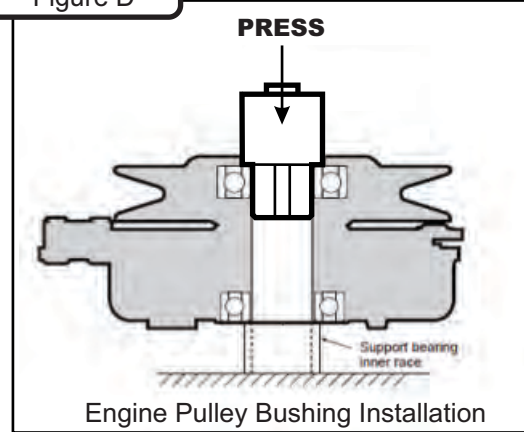

Figure C



The engine pulley assembly must be installed using an arbor press or equivalent. During installation, opposite bearing inner race must be supported or bearing damage may occur. Refer to Figure D.

Figure D



Once the Engine Pulley Bushing is installed, reattach the clutch assembly & deck PTO belt to the mower and then review Figure E.

Figure E

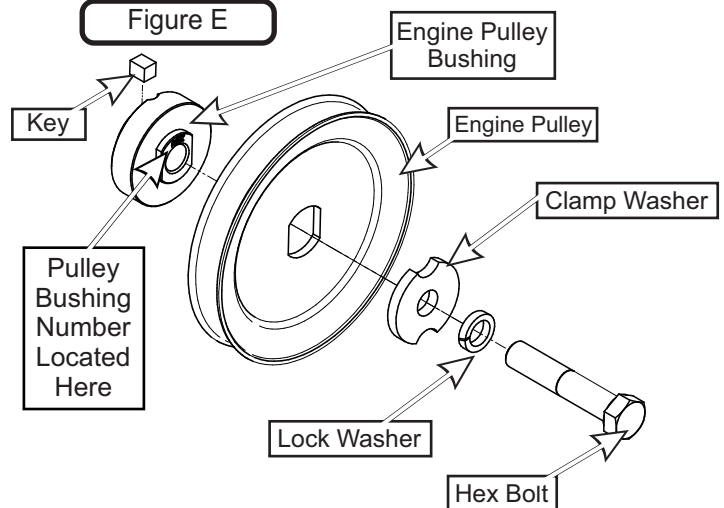

To assemble and fasten the Engine Pulley, align the Engine Pulley Bushing and Key to the mower's clutch pulley and fasten using (1) Clamp Washer, (1) Lock Washer, and (1) Hex Bolt. Torque the bolt to 55 ft./lbs. The added pulley will power the collection system and should resemble Figure F when installed.

Figure F

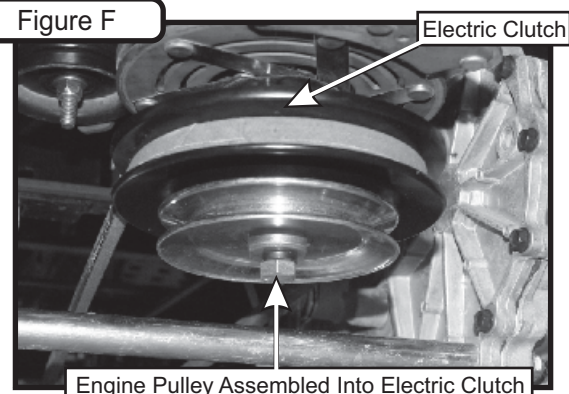

## Rear Mount Kit Assembly Installation

To install the Rear Mount Kit, first attach the Rear Mount Plate (#1) to the rear bumper and fasten using (2) 3/8"-16" x 2" Carriage Bolts (#11), (2) Spacer Bushings (#5) and (2) 3/8"-16 Ny-Flange Lock Nuts (#7). Next, fasten the bottom of the Rear Mount Plate to the bottom of the rear bumper using (2) 3/8"-16" x 1-1/2" Carriage Bolts (#10), (2) Spacer Bushings (#9) and (2) 3/8"-16 Ny-Flange Lock Nuts (#7). Next, install the Left Mount Plate (#3), remove the bottom two pre-existing bolts and attach the Left Mount Plate to the Rear Mount Plate using (2) 3/8"-16 x 1" Carriage Bolts (#6) and (2) 3/8"-16 Ny-Flange Lock Nuts (#7). Fasten the bottom of the Left Mount Plate with (1) 3/8"-16 x 1" Carriage Bolts (#6), (1) 3/8"-16 x 1-1/4" Carriage Bolt (#8), and (2) 3/8"-16 Ny-Flange Lock Nuts (#7). Next, install the Right Mount Plate (#2) by removing the bottom two pre-existing bolts and nuts as well as the top bolt used on the ROPS (save the washer). Attach the Right Mount Plate to the Rear Mount Plate by using (2) 3/8"-16 x 1" Carriage Bolts (#6) and (2) 3/8"-16 Ny-Flange Lock Nuts (#7). Fasten the Right Mount Plate to the rear bumper by using (1) 3/8"-16 x 1" Carriage Bolt (#6), (1) 3/8"-16 x 1-1/4" Carriage Bolt (#8), and (2) 3/8"-16 Ny-Flange Lock Nuts (#7) on the bottom and using (1) 1/2"-13 x 3-1/2" HHCS (#12), (1) 1/2"-13 Ny-Flange Lock Nut (#14) and the pre existing washer.

To Install the Exhaust Diverter (#4), attach the receiving end of the Exhaust Diverter to the opening of the exhaust, angled 45-60 degrees downward, and secure the Exhaust Diverter using (1) 1-1/2" Exhaust Clamp Kit (#15).

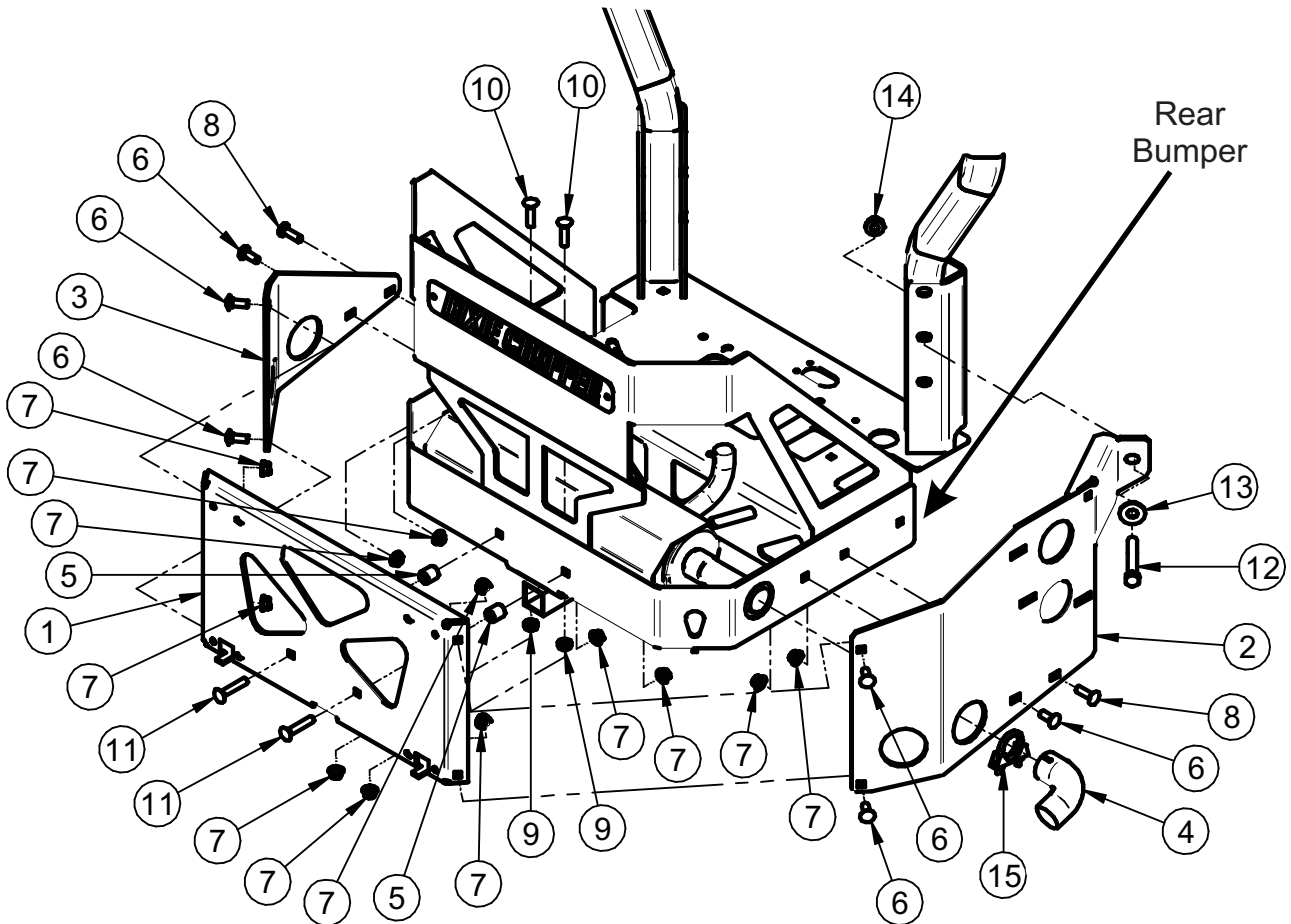

Item #	Part #	Desc.	Qty.
1	B0980	Rear Mount Plate	1
2	B0981	Right Mount Plate	1
3	B0982	Left Mount Plate	1
4	J0293	1-1/2" Exhaust Diverter	1
5	S3242	Spacer Bushing / .750 ID x .380 ID x .830 L	2
6	K1182	Carriage Bolt 3/8"-16 x 1"	6
7	K2038	Ny-Flange Lock Nut 3/8"-16	12
8	K1183	Carriage Bolt 3/8"-16 x 1-1/4"	2
9	S3287	Spacer .437 ID x .750 OD x .250 T	2
10	K1337	Carriage Bolt 3/8"-16 x 1-1/2"	2
11	K1184	Carriage Bolt 3/8"-16 x 2"	2
12	K1237	1/2"-13 x 3-1/2" HHCS GR5	1
13	K0055	Flat Washer 1/2" / 1.383 OD x .560 ID x .120 T	1
14	K2012	1/2"-13 Ny-Flange Lock Nut	1
15	X1064	1-1/2" Exhaust Clamp Kit	1

## PTO Mount Assembly Installation

To install the PTO Mount, first attach the Right PTO Mount Plate (#2) to the Right Mount Plate using (2) 3/8"-16 x 1" Carriage Bolts (#6) and (2) 3/8"-16 Ny-Flange Lock Nuts (#7). Next, attach the Left PTO Mount Plate (#1) to the Right Mount Plate using (2) 3/8"-16 x 1" Carriage Bolts (#6) and (2) 3/8"-16 Ny-Flange Lock Nuts (#7). Lastly, attach the PTO Stop Plate (#3) between the Right PTO Mount Plate and the Left PTO Mount Plate using (4) 1/4"-20 x 3/4" HHCS (#4) and (4) 1/4"-20 Ny-Flange Lock Nuts (#5).

Item #	Part #	Desc.	Qty.
1	B0984	Left PTO Mount Plate	1
2	B0983	Right PTO Mount Plate	1
3	B0736	PTO Stop Pl.	1
4	K1222	1/4"-20 X 3/4" HHCS	4
5	K2014	1/4"-20 Ny-Flange Lock Nut	4
6	K1182	Carriage Bolt 3/8"-16 x 1"	4
7	K2038	Ny-Flange Lock Nut 3/8"-16	4

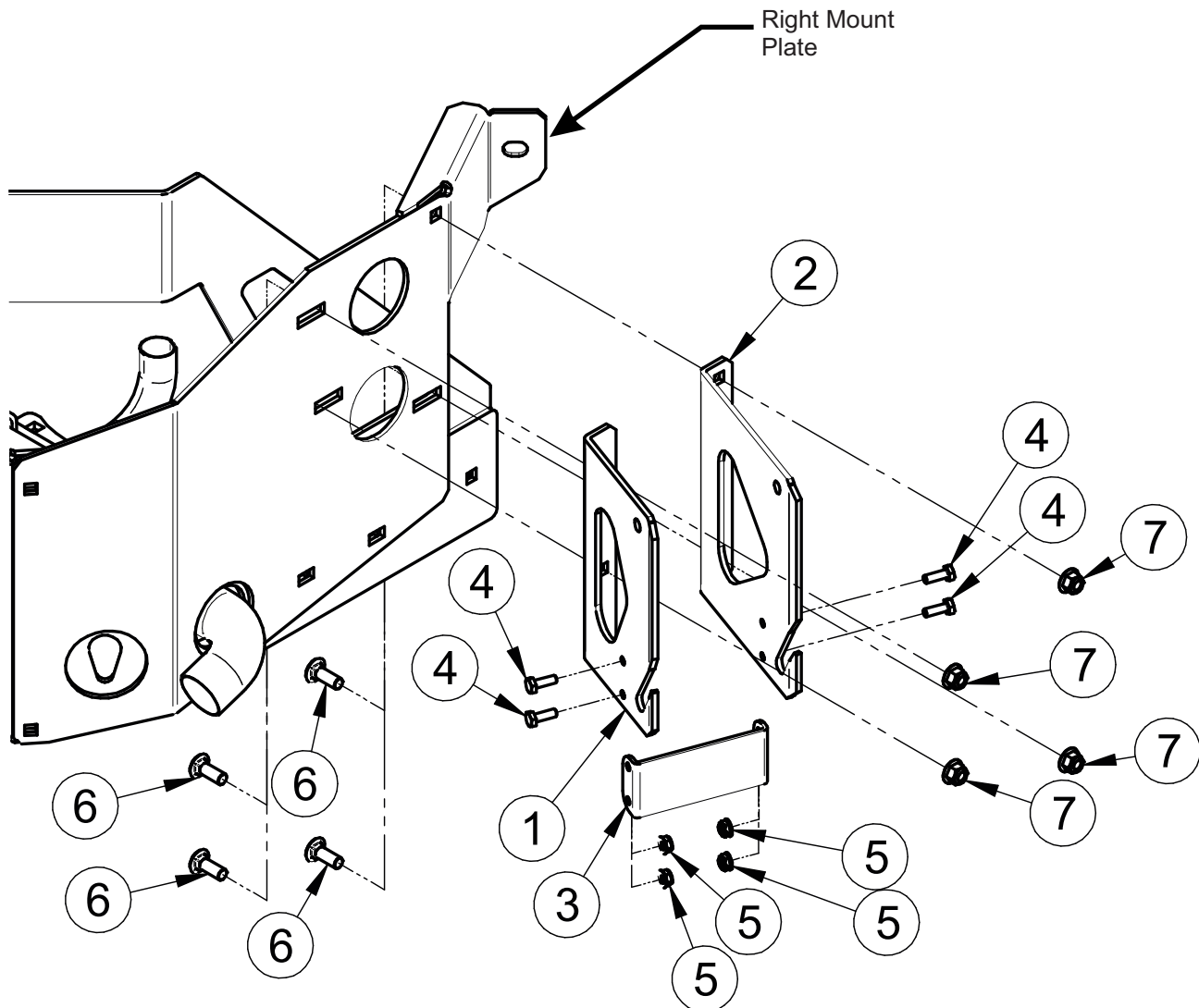



## PTO Assembly & Handle Assembly Installation

To mount the PTO Assembly, insert the Pivot Rod on the PTO Assembly P#(A1950) into the mounting slots located on the Left & Right PTO Mount Plates (Figure A). Tilt the PTO Assembly upward and insert the PTO Mount Pin P#(B0274) through the hole in the top of the Right PTO Mount Plate Assembly. Secure the PTO Mount Pin using 3/32" Hair Pin Clip P#(K0099) as shown below.

**Note:** Remove the gearbox pulley guard in preparation for the belt installation. Refer to Figure A.

To install the PTO Handle P#(A0626), attach the PTO Handle P#(A0626) to the PTO Assembly using (3) 1/4"-20 x 3/4" HHCS P#(K1222) and (3) 1/4"-20 Ny-Flange Locknuts P#(K2014). Attach the Handle Grip P#(J0522) to the PTO Handle. Refer to figure B

**NOTE:** The PTO Handle can be adjusted after achieving proper belt adjustment. To adjust the handle, remove (3) 1/4"-20 x 3/4" HHCS P#(K1222) and (3) 1/4"-20 Ny-Flange Locknuts P#(K2014), rotate handle until positioned in the desired location (while aligning holes) and reattach. The bolts should be kept approximately 120 degrees apart to ensure proper fastening.

Figure A

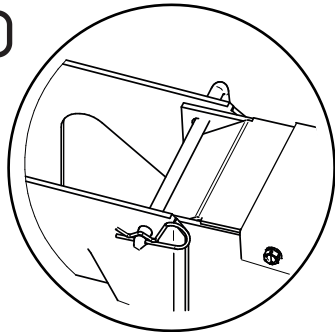

PTO Mount Pin P#(B0274)  
and hair pin clip P#(K0099)

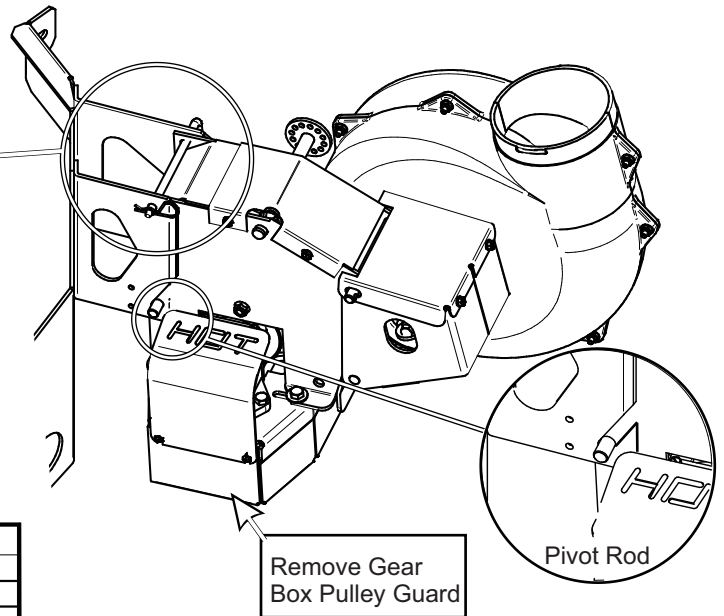

Pivot Rod

Remove Gear  
Box Pulley Guard

Figure B

Item #	Part #	Desc.	Qty.
1	A0626	PTO ENGAGE. HANDLE ASSY.	1
2	J0522	HANDLE GRIP, ROUND BLACK .800 ID	1
3	K1222	1/4"-20 X 3/4" HHCS	3
4	K2014	1/4"-20 Ny-Flange Lock Nut	3

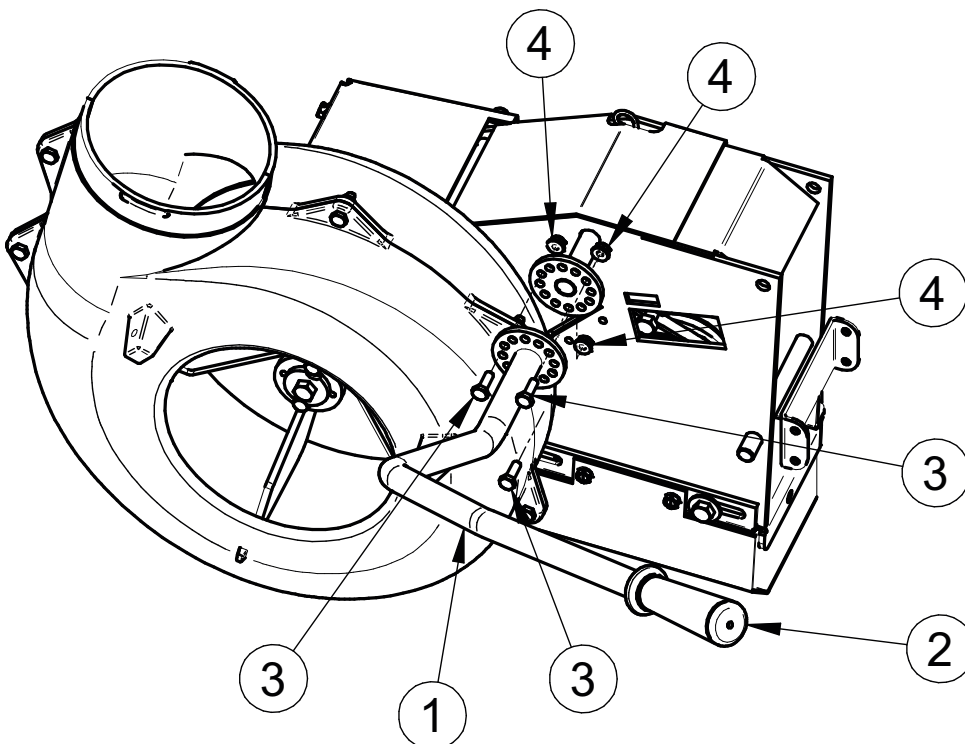

## Belt Installation & Adjustment

Loosen the (4) bolts P#(K1191), (2) on each side, that secure the gear box assembly to the PTO assembly P#(A1950) (Figure A and B).

Figure A

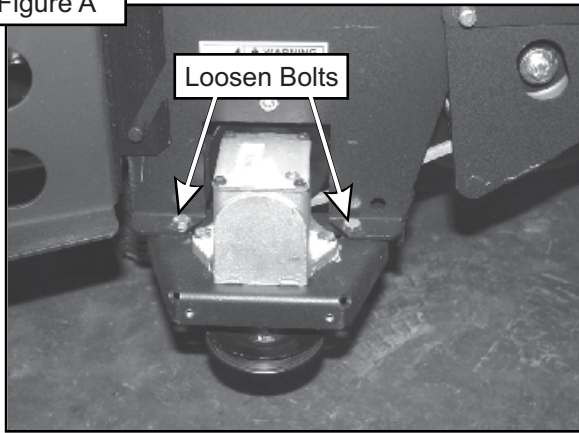
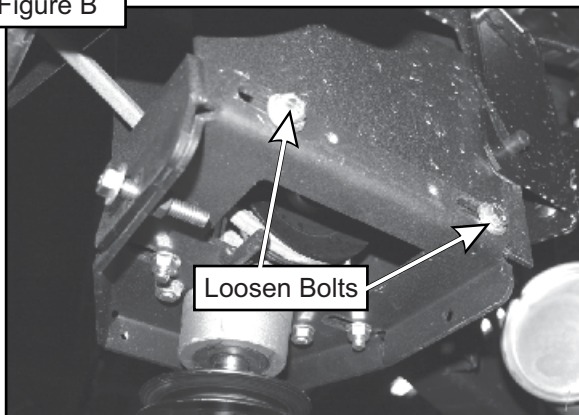
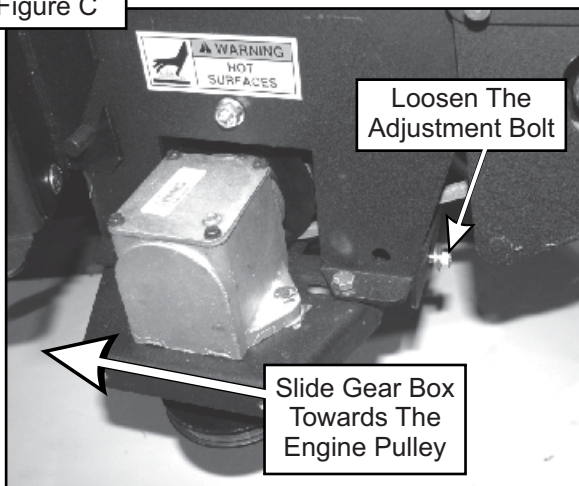

Figure B



Loosen the adjustment bolt P#(K0348) until the gear box assembly is at its far left adjustment (the gear box is moved toward the mower's engine pulley). Refer to Figure C.

Figure C



Connect the belt A56K P#(M0239) from the engine pulley to the lower gear box pulley (Figure D).

Figure D

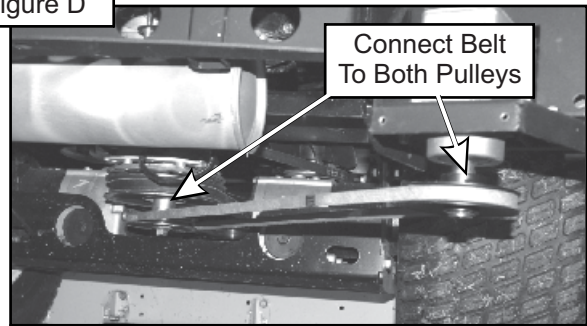

To tension the drive belt, turn the adjustment bolt clockwise (Figure E) until there is 1" of deflection, with 10-11 lbs. of pressure, at the center of the belt between the engine pulley and the gear box pulley.

Figure E

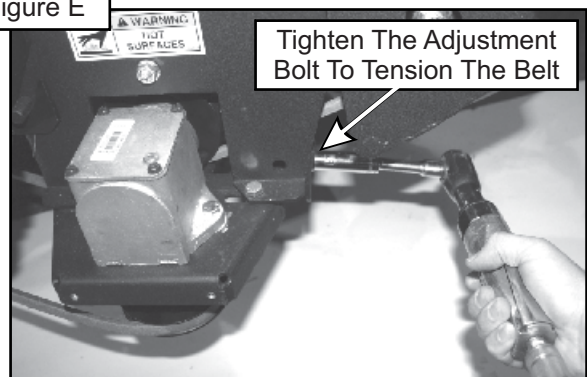

Once the correct tension of the belt is achieved, tighten the (4) bolts that secure the gear box assembly. Refer to Figures F and G. Replace the belt guard and hardware that was removed in the previous step.

Figure F

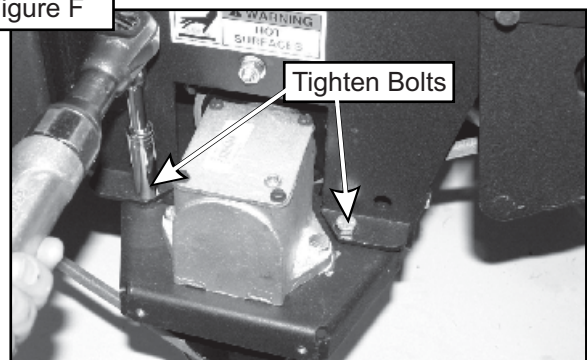
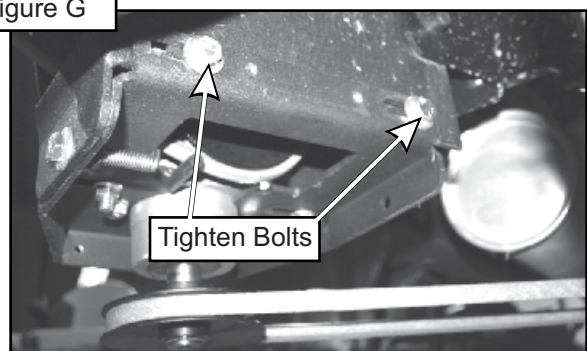

Figure G



## Cam Assembly Adjustment

The Cam Assembly P#(A0422), which controls the blower belt tension, comes from the factory pre-adjusted.

If the belt is too tight or becomes too loose, remove the Hair Pin Clip P#(K0130) from the Belt Tension Rod P#(K0326) and pull the "L" end of the rod out of its hole in the Cam Assembly.

The Tension Rod may then be screwed out to tighten the belt or screwed in to loosen the belt. Replace the "L" end into the top hole in the cam and replace the Hair Pin Clip.

Adjust the Cam Stop Bolt P#(K1159) to allow the cam to rotate slightly over center when the blower is engaged (Figure A).

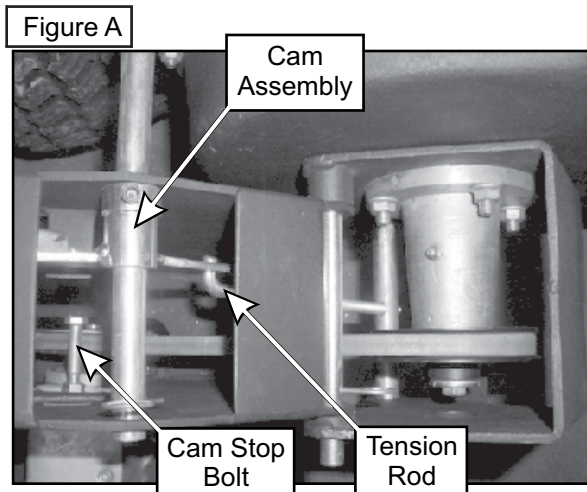

## Blower Cone Installation

Thread (1) 5/16"-18 Jam Nut P#(K0120) onto each end of (2) 5/16"-18 x 2-1/2" HHCS P#(K0125) as shown in Figure B.

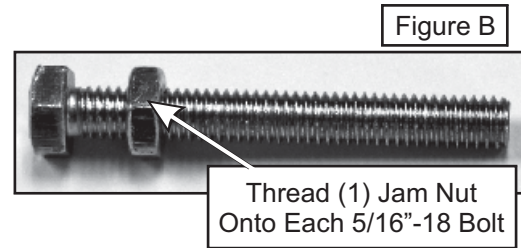

Now partially thread (1) bolt into each of the two threaded bosses located on the blower housing. Place Blower Cone so the two tabs line up with the bolts and tighten completely as shown in Figure C.

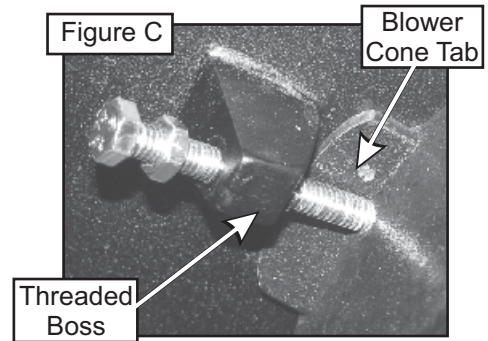

Once the (2) bolts are tight, tighten the Jam Nuts against the threaded boss as shown in Figure D.

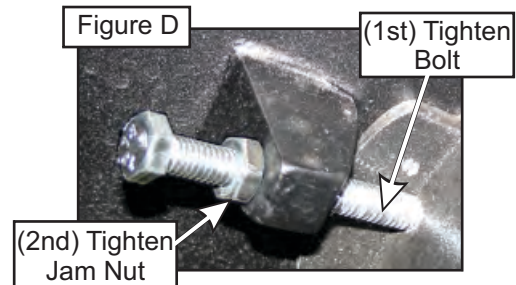

Refer to Figure E for proper Blower Cone installation reference.

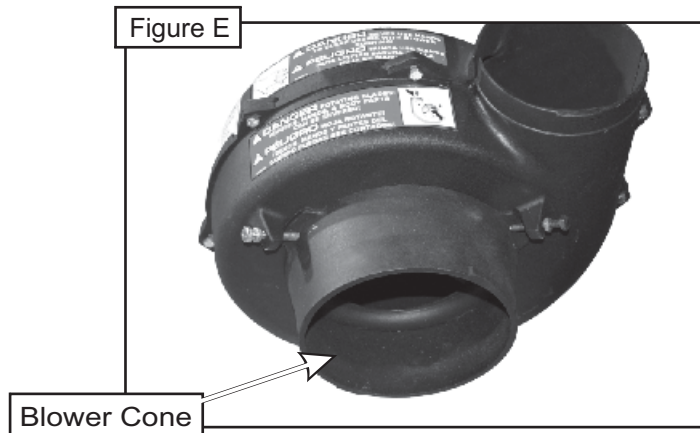

## Boot Kit Installation

Step 1 - Remove the mower's Operator Controlled Discharge Chute (OCDC) and attach the Boot Plate Adapter (Item #7) to the far right mounting hole as shown in Figure B using (1) 3/8"-16 x 1" Hex Head Cap Screw (Item #8), (1) 3/8" Flat Washer (Item #9) and (1) 3/8"-16 Ny-Flange Lock Nuts (Item #6).

Step 2 - Secure the Boot Plate (Item #2) to the Aluminum Boot (Item #1) using (2) 3/8"-16 x 1" Carriage Bolts (Item #5) and (2) 3/8"-16 Ny-Flange Lock Nuts (Item #6). Insert the Carriage Bolts from the inside of the Boot so the threads are on the top of the Boot. This will prevent grass clippings from collecting on the threads. Leave the hardware loose until the boot plate has been attached to the mower deck.

Step 3 - Align Boot Plate Bushings to the Boot Plate Adapter Bushings.

Step 4- Insert Boot Rod (Item #3) through the Boot Plate Adapter & Boot Plate Bushings.

Step 5 - Secure the Boot Rod using a Hair Pin Clip (Item #4).

Step 6 - With the Carriage Bolts (Item #5) still loose, adjust the position of the boot so that there is no gap between the mower deck and the boot.

Step 7 - Tighten all hardware at this time.

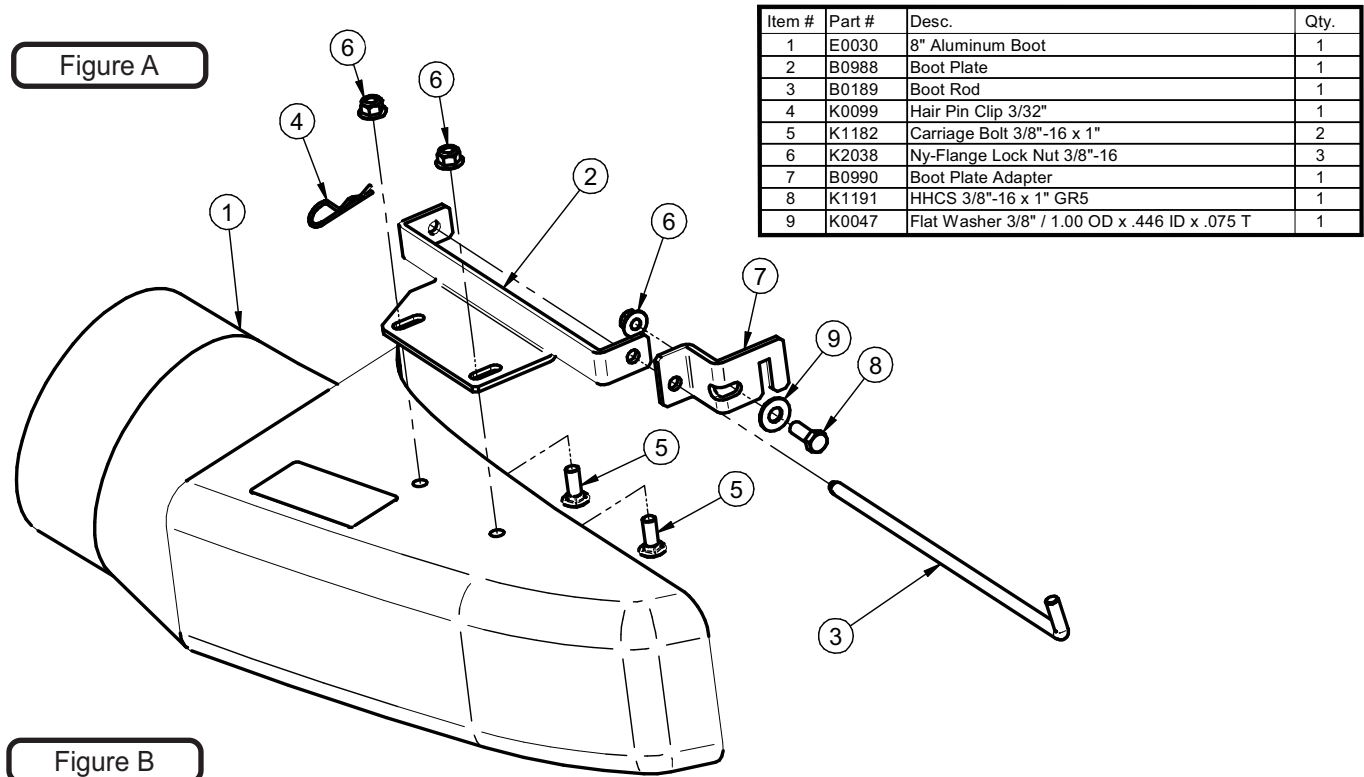

## Lower Mount Tube Installation

Secure the (2) Lower Mount Tubes (Item #1) to the Rear Mount Plate using (2) 5/16"-18 U-Bolts (Item #2) and (4) 5/16"-18 Ny-Flange Lock Nuts (Item #3) PER TUBE. Refer to Figure A.

## Upper Frame Assembly Installation

Position the Upper Frame Assembly (Item #4) above the Lower mount tubes as shown in Figure A Slide the Upper Frame Assembly down onto the Lower Mount Tubes and secure using (2) Clevis Pins (Item #5) and (2) Hair Pin Clips (Item #6).

Item #	Part #	Desc.	Qty.
1	B0640	Lower Mount Tube / 29"	2
2	K1098	U-Bolt / 5/16"-18 x 2" x 2-1/2"	4
3	K2516	Ny-Flange Lock Nut 5/16"-18	8
4	A2068	Upper Frame Assembly P3B Generic Gen 2	1
5	K0133	Clevis Pin 1/2" x 2-1/2"	2
6	K0088	Hair Pin Clip 5/32" x 2-5/8" L	2

Figure A

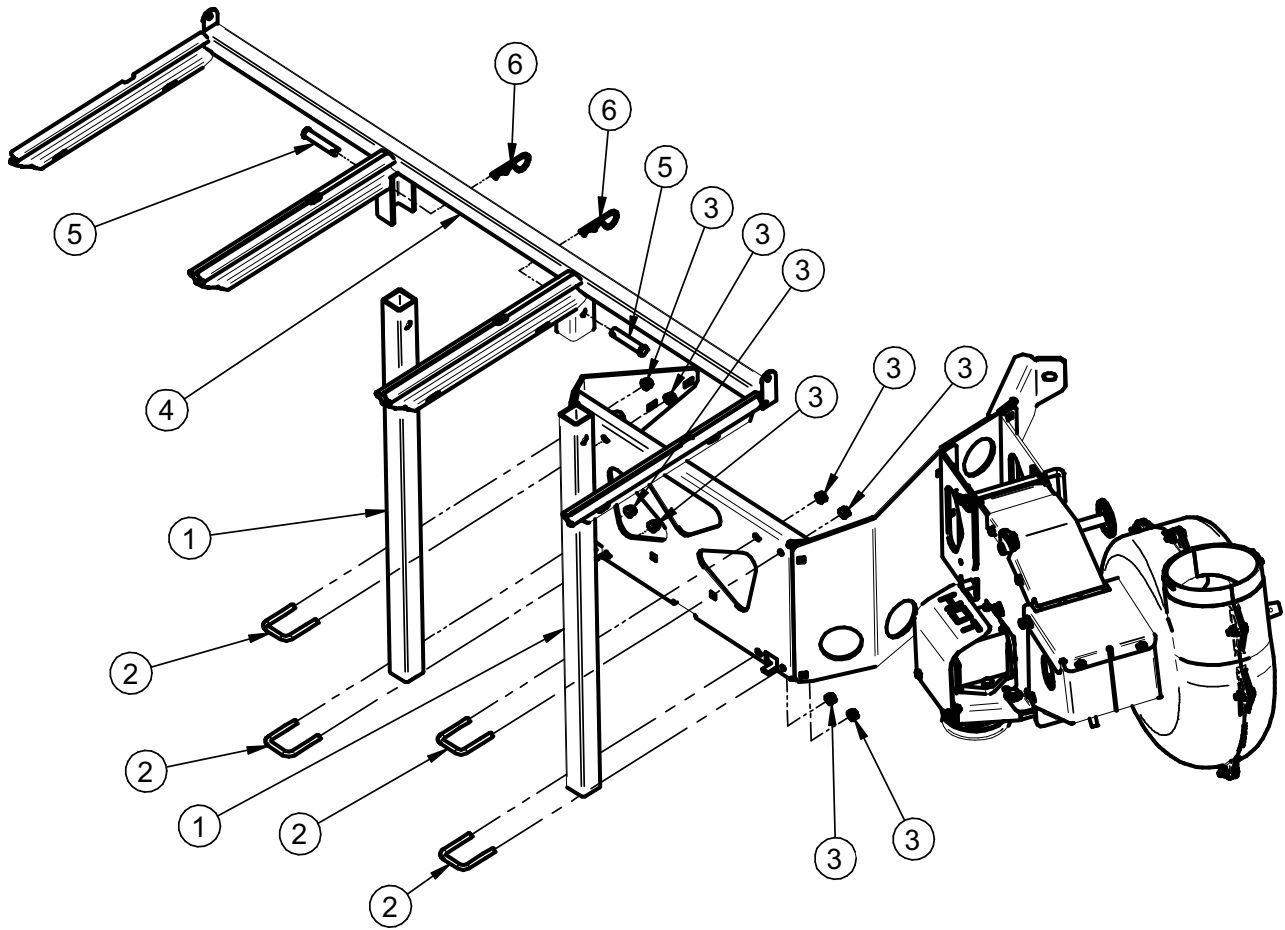

## Top Assembly To Upper Frame Assembly Installation

Align the Top Assembly Pivot Holes to the Upper Frame Assembly. See Figure A below. Before fastening, pull Rubber Dust Guard outward to seal against Upper Frame Assembly (towards the mower's operator seat). Fasten the Top Assembly to the Upper Frame Assembly using (2) 5/16"-18 x 2-1/2" HHCS P#(K0125) and (2) 5/16"-18 Ny-Flange Locknuts P#(K2516). Leave the Ny-Flange Locknuts slightly loose to allow the Top Assembly to open and close easily.

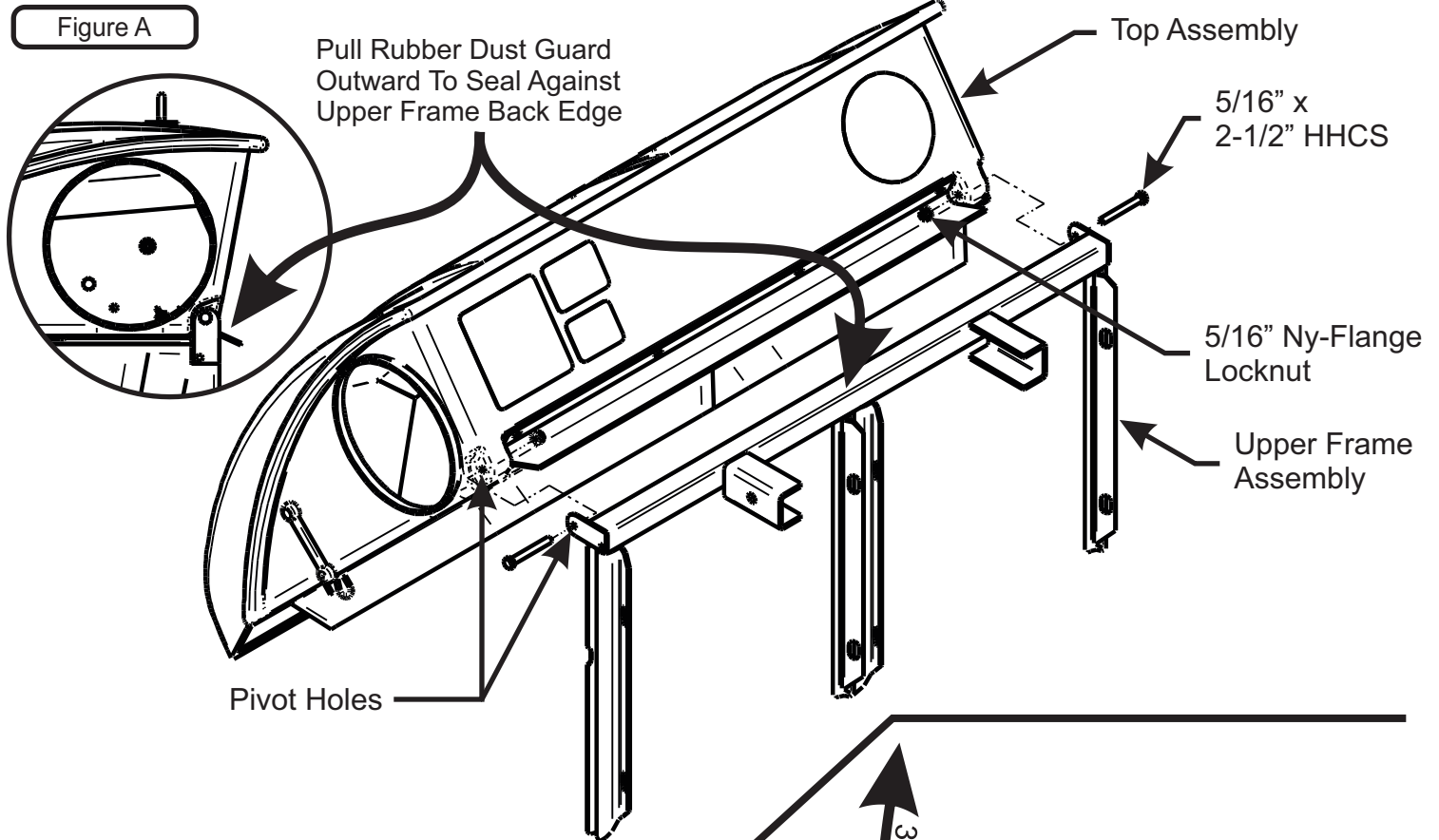

## Inlet Installation

Position the Top Assembly on its side with the Inlet Hole facing up. See Figure B. 1: Insert the Inlet from inside the Top Assembly, up through the Inlet Hole, until the Inlet Retaining Lip meets the Inlet Hole. 2: Position the Inlet as shown in Figure B, then pull the Inlet until a portion of the Inlet Retaining Lip protrudes from the Inlet hole. 3: Next, lift the Inlet as shown in Figure B until all of the Inlet Retaining Lip protrudes from the Inlet Hole. Once installed, the Inlet should pivot freely about the Inlet Hole.

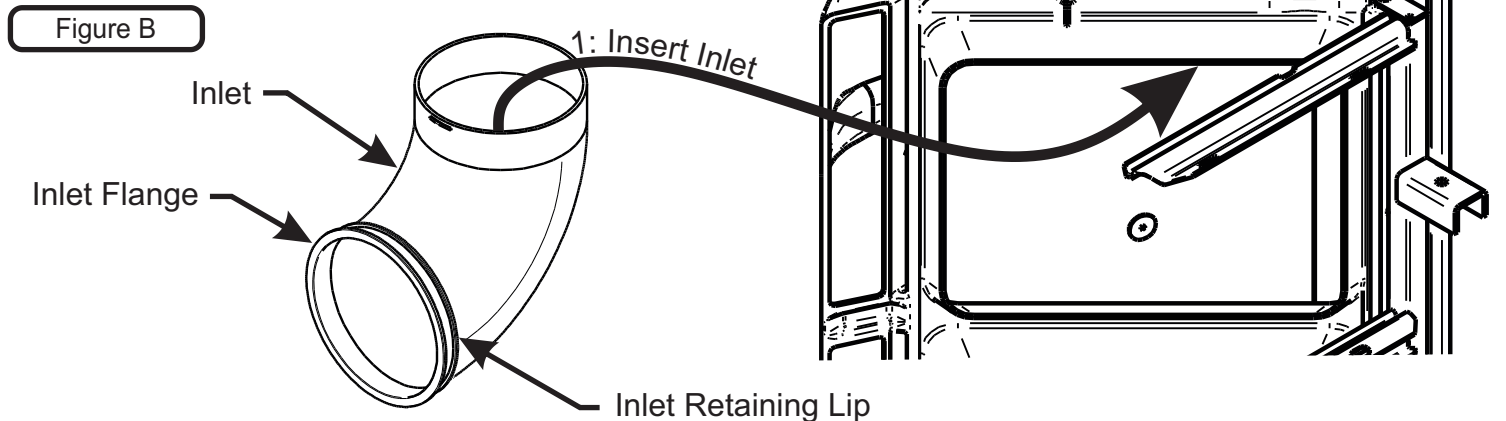

## Hinge Kit Assembly Installation

Assemble the Hinge Kit using (1) Latch Plate P#(B0884), (1) 5/16"-18 x 1-1/4" HHCS P#(K1156), (1) 5/16"-18 Ny-Flange Lock Nut P#(K2516), (3) 5/16" Flat Washers P#(K0042), (1) Latch Spacer P#(S0006), (2) Extra Heavy 5/16" Fender Washers P#(K0505) and (1) 5/16"-18 Lock Nut P#(K0506). Leave the nuts loose enough to allow fluid movement of the top when opening and closing. When opened, the top should rest in the Latch Plate Slot.

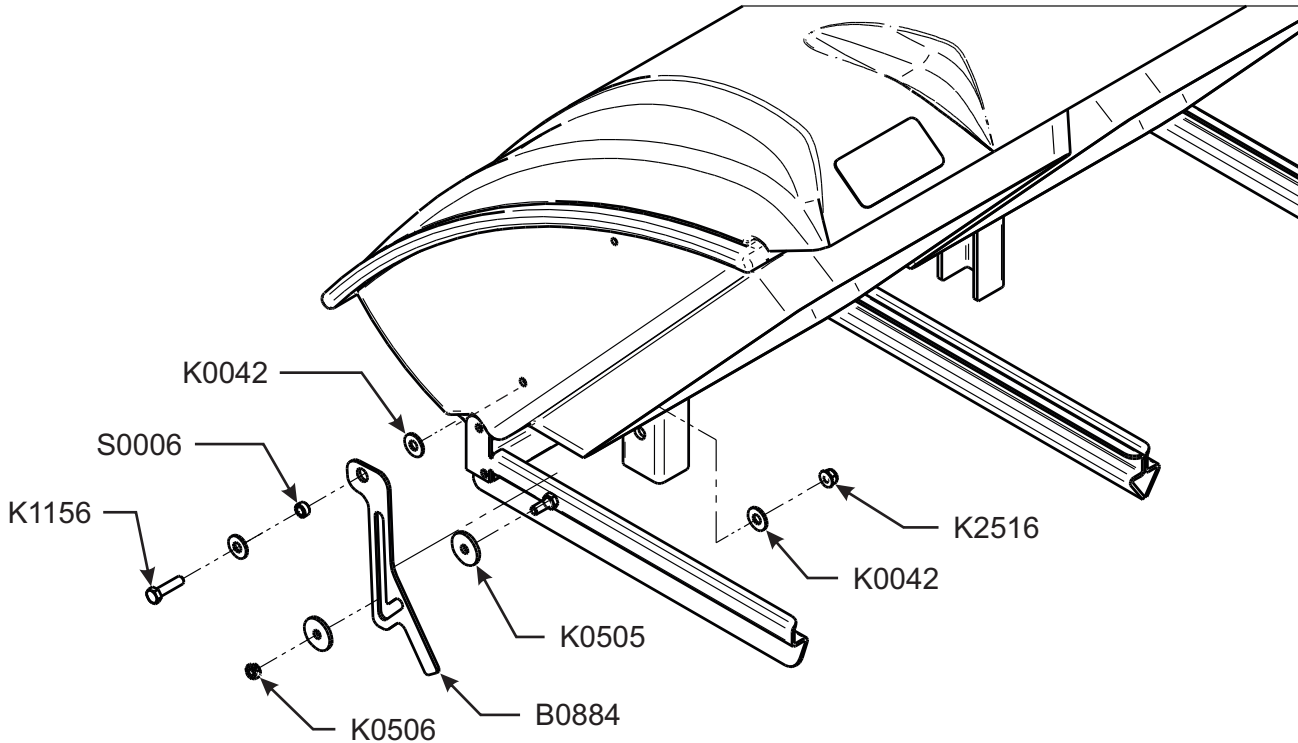

## Even Bag Fill Adjustment

Flap can be adjusted Up/Down depending on mowing conditions. Adjust flap up to allow more dense material to reach left bag. Adjust flap down to allow less dense material to reach the right bag. Once adjusted properly, both bags should fill evenly, but may require further adjusting when mowing conditions change.

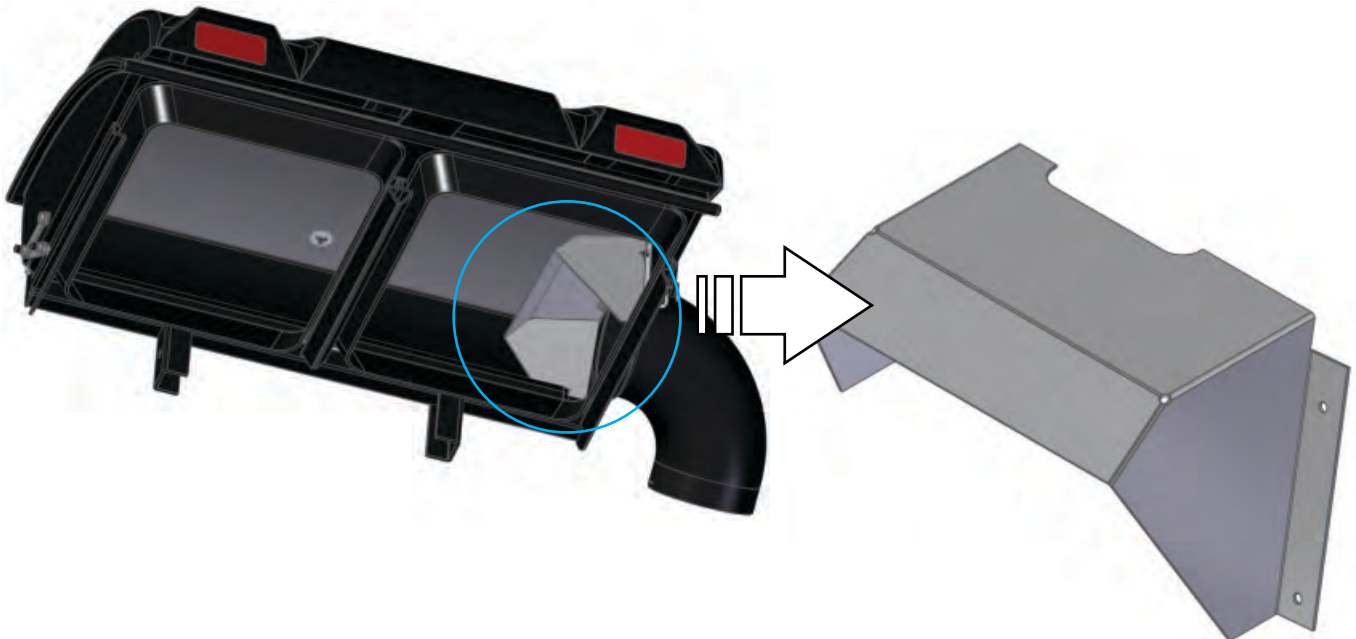

## Length Of Hose Adjustment

The hoses in the following steps must be cut to fit your machine. Do not cut the hoses until you have tried to fit them on your machine. Remember that the hoses need to be long enough to allow for the opening and closing of the collection system as well as allowing ample clamping surface between each component.

## Upper Hose Installation

Slide a Hose Clamp P#(J0060) over one end of the 6" Upper Hose. Secure this end of the 6" Upper Hose to the Blower Outlet. See Figure below for details. Secure opposite end of the 6" Upper Hose to the Inlet with another Hose Clamp P#(J0060). Make sure both ends are securely fastened by tightening the Hose Clamp.

## Lower Hose To Blower Cone Installation

Slide a Hose Clamp P#(J0080) over both ends of the Lower Hose. Secure one end of the Lower Hose to the Blower Cone and fasten by tightening the Hose Clamp.

## Lower Hose To Boot Installation

Take the unattached end of the Lower Hose and secure it to the circular end of the Boot and fasten by tightening the Hose Clamp.

Tip: Before securing Hose Clamp fully, rotate Lower Hose counter-clockwise (away from yourself) approximately 1" to aid in retaining Boot to mower deck.

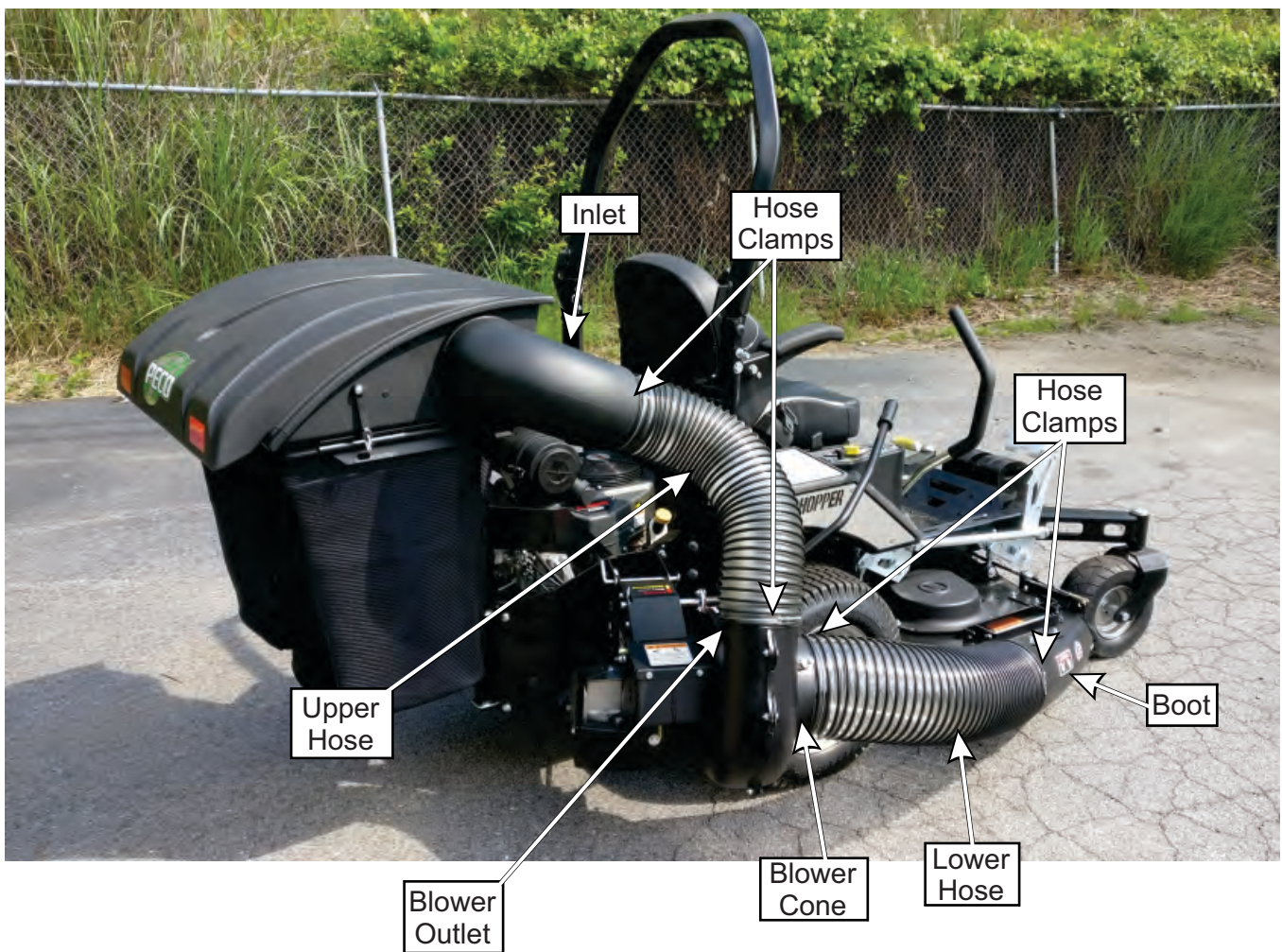



## **Bag Assembly**

First, take one of the Bag Ring Split Ends and insert it through the Bag Seam Opening. Next, rotate the Bag around the Bag Ring (1) full turn (360 degrees) until the Bag Ring Split Ends and the Bag Seam Opening are positioned on the same side. Then, connect the Bag Ring Split Ends using (1) End Connector. Last, rotate the Bag Ring and the End Connector Assembly (1/2") turn (180 degrees) to position the Connector opposite of the Bag Seam Opening. Note Final End Connector Location below in Figure A. Repeat for each Bag.

Figure A

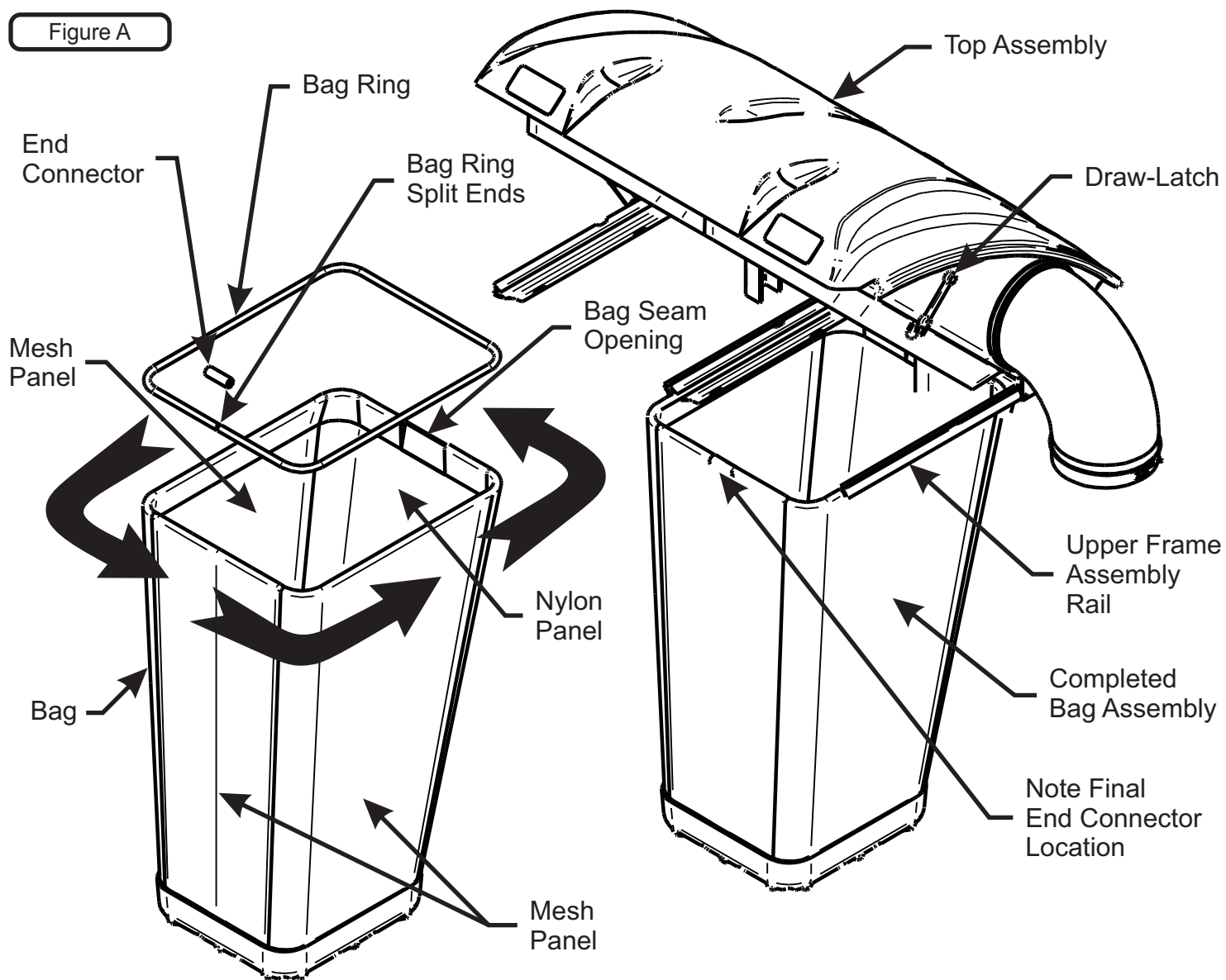

## **Bag Assembly Installation**

Slide the Completed Bag Assembly into the Upper Frame Assembly Rails and close the Top Assembly. Fasten the Draw-Latch on either side to hold the bagger closed.

## Impeller Blade Removal/Replacement

**To Remove:** First remove the 5/16"-24 x 1" HHCS P#(K0428) (#1), Taper Lock Bushing Washer P#(K0284) (#3), (2) 5/16 Flat Washers P#(K0042) and Spacer Bushing P#(S0159) (#4) from the Taper-Lock Bushing P#(S0157) (#5). Next remove the (2) 1/4"-20 x 1" HHCS (#2) and place them into the threaded holes of the Taper-Lock Bushing (#5). Gradually thread each bolt evenly into the Taper-Lock Bushing, forcing the blade to break-away from the Taper-Lock Bushing. If the Impeller will not move, carefully hit the base of the Impeller, between each vein, with a hammer, then try again.

**To Replace:** Place Impeller Blade over the engine shaft. Slide the Taper-Lock Bushing (#5) on to the engine shaft and into the Impeller Blade, aligning the **non-threaded** holes of the Taper-Lock Bushing to the threaded holes of the Impeller Blade. Fasten by using (2) 1/4"-20 x 1" HHCS (#2), (1) Spacer Bushing (#4) (1) Taper-Lock Bushing Washer (#3), and (1) 5/16"-24 x 1" HHCS (#1). Torque to the proper specifications in the torque chart on the back of this manual. Next, rotate the Impeller Blade to ensure that the blade is clear of contact on all sides of the blower housing.



# Weight Kit Installation

Step 1 - Remove the existing front name plate by removing the top two screws and bottom two screws. Refer to Figure A.

Step 2 - Remove the footrest to expose (4) large carriage bolts and nuts, located behind the name plate.

Step 3 - Remove and keep (2) existing nuts from the existing carriage bolts, (1) from the far lower left and (1) from the far lower right. Refer to Figure B.

Step 4 - Place Weight Bracket (#1) over the front of the mower and under the footrest as shown in Figure B. Replace and tighten the (2) nuts from Step 3 to the existing carriage bolts.

Step 5 - Insert (2) Suitcase Weights (#2) per side onto the weight bracket & align the holes of the Suitcase Weights to the holes of the Weight Bracket.

Step 6 - Secure each set of (2) Suitcase Weights by using (1) Hitch Pin (#3) and (1) Hair Pin Cotter (#4).

Figure A



Figure B

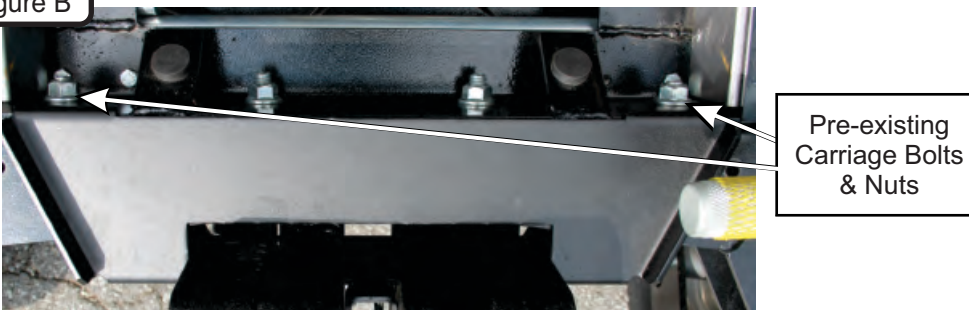

Item #	Part #	Desc.	Qty.
1	B0989	Weight Bracket	1
2	Y0025	28 lb. Suitcase Weight	4
3	A0312	Hitch Pin Weldment	2
4	K1478	Hair Pin Cotter / Double Loop	2

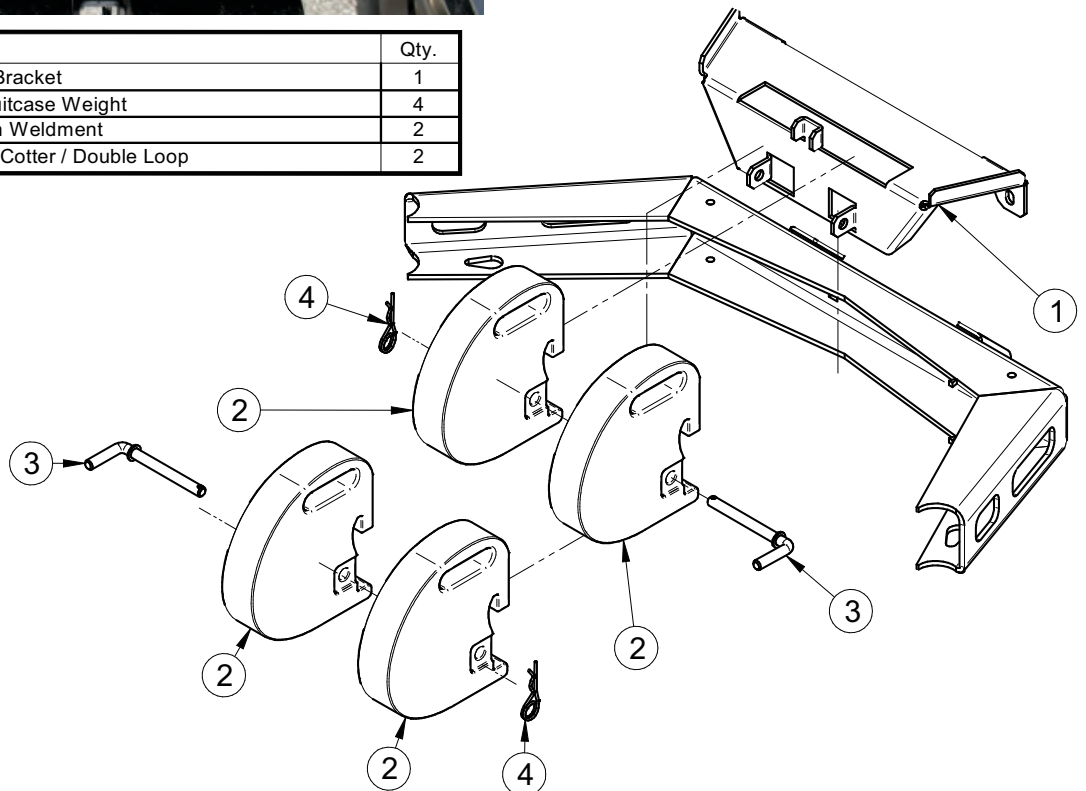

# A1950 PTO Assembly Exploded Parts View

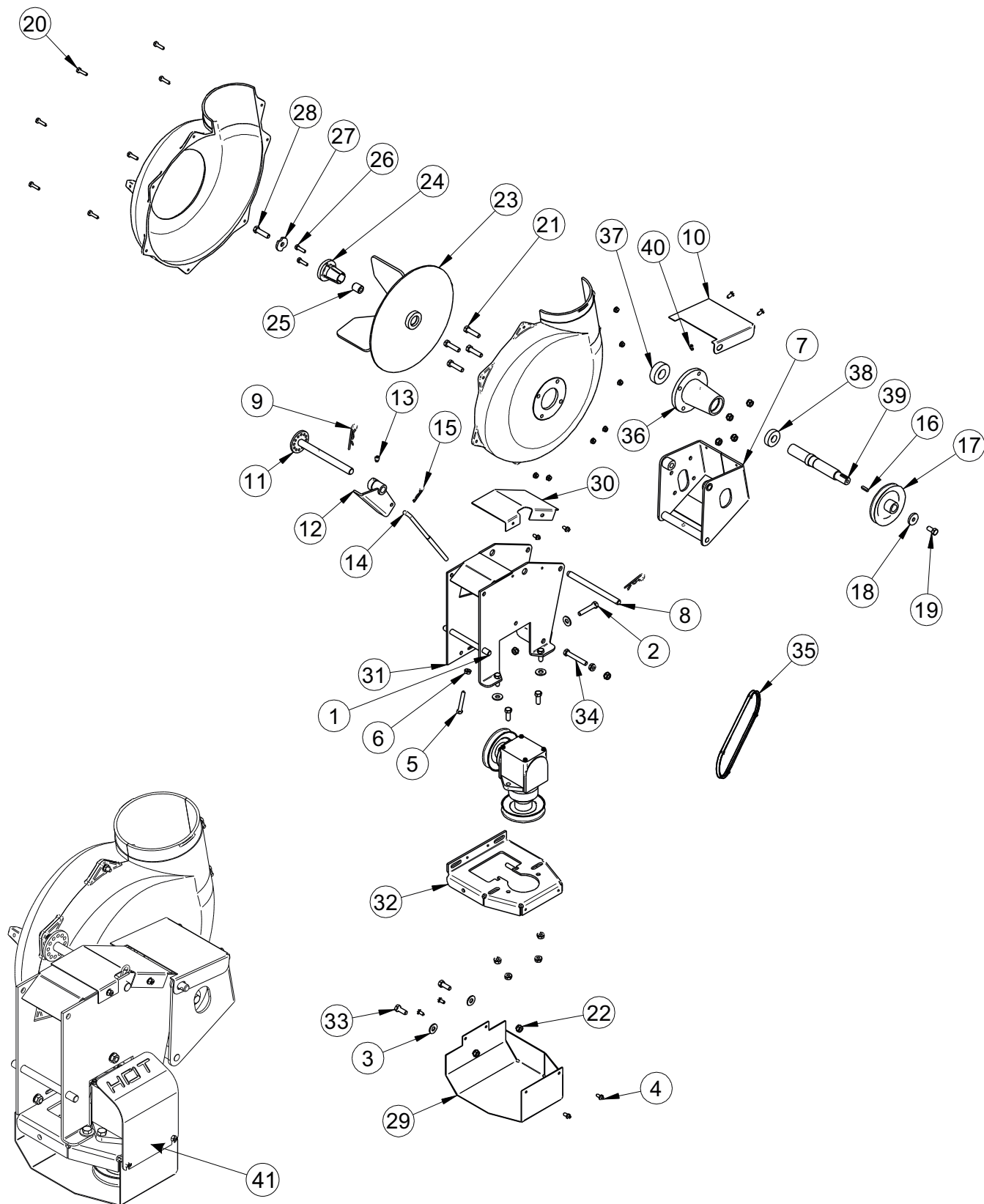

## A1950 PTO Parts List

Item Number	Document Number	Title	Quantity
1	A0429	GEAR BOX ASSEMBLY	1
2	K0348	3/8"-16 x 2" ALL THREAD HHCS	1
3	K0047	3/8" FLAT WASHER 1.00 OD x .446 ID x .075 T	5
4	K0353	1/4"-20 x 1/2" HHSTS	8
5	K1159	5/16"-18 x 2" ALL THREAD HHCS	1
6	K1178	5/16"-18 FLANGE NUT	1
7	A0144	BLOWER MOUNT BRACKET ASSEMBLY	1
8	B1755	BLOWER PIVOT ROD	1
9	K0086	.125 OD x 2.50 HAIR PIN CLIP	2
10	B0121	BLOWER BELT GUARD	1
11	A0604	PTO HANDLE MOUNT ASSY	1
12	A0422	CAM BRACKET ASSEMBLY	1
13	K0356	3/8"-16 TAPERED SET SCREW	1
14	K0326	BELT TENSION ROD 3/8"-16	1
15	K0130	.091 OD x 1.625 L HAIR PIN CLIP	1
16	J0254	3/16" SQ. x 3/4" LONG KEYWAY	1
17	M0228	BLOWER PULLEY	1
18	K1446	1.187 OD x .380 ID x .187 WASHER	1
19	K1190	3/8"-16 x 3/4" HHCS	1
20	E4004A	BLOWER HSG. ASSY.	1
21	K1193	3/8"-16 x 1-1/2" HHCS	4
22	K1215	3/8"-16 FLANGE NUT	12
23	A0645	SMALL 4-BLADE IMPELLER	1
24	S4302	TAPER-LOCK BUSHING	1
25	S3242	PLATED BUSHING	1
26	K1225	1/4"-20 X 1" HHCS GRADE 8	2
27	K0278	TAPER-LOCK BUSHING WASHER	1
28	K1211	3/8"-16 x 1-1/2" HHCS GRADE 8	1
29	B0269	GEAR BOX PULLEY GUARD	1
30	B0270	PTO ARM GUARD	1
31	A0622	PTO ARM ASSY.	1
32	A0624	BASE PLATE ASSY.	1
33	K1191	3/8"-16 x 1" HHCS	6
34	K1197	3/8"-16 X 2 1/2" HHCS	1
35	M0250	A30K KEVLAR BELT	1
36	E0121	PTO SHAFT HOUSING	1
37	N0147	BEARING 2.0472 OD, 0.9843 ID, 0.5906 W (6205RS PEER)	1
38	N0148	BEARING 1.625 OD, 0.75 ID, 0.4375 W (9R12 PEER)	1
39	B1758	PTO SHAFT	1
40	J0801	1/4"-28 ZIRC FITTING	1
41	B0833	GEAR BOX HEAT GUARD	1

# A2101 Top Assembly Exploded Parts View

Item #	Part #	Desc.	Qty.
1	V2000	Pro 2 Bagger Top / Gen. 2	1
2	V2001	Screen	1
3	J4009	Short Rubber Strap w/ S-Hook	2
4	K1030	1/4"-20 x 1-1/4" Carriage Bolt	2
5	K0037	Flat Washer / 1/4" (.75 OD x .312 ID x .060 T)	2
6	K1128	1/4"-20 Nyloc Nut	2
7	K0062	Fender Washer / .230 ID x 1.500 OD / Zinc	2
8	K0114	Black Plastic Rivet	11
9	C0067	Dust Guard Mnt. Brkt.	1
10	V1117	Dust Guard	1
11	R0022	Decal / Built In The USA / Lg	1
12	R1069	Decal / Warning - Turn Off Blower	1
13	R1054	Decal / Important Check Hoses	1
14	R1051	Decal / Warning - Use Hearing Protection	1
15	R1057	Decal / 2" x 4" Red Reflector	2
16	C0026	Grass Deflector	1
17	B0676	Hinge Stop Pl.	1

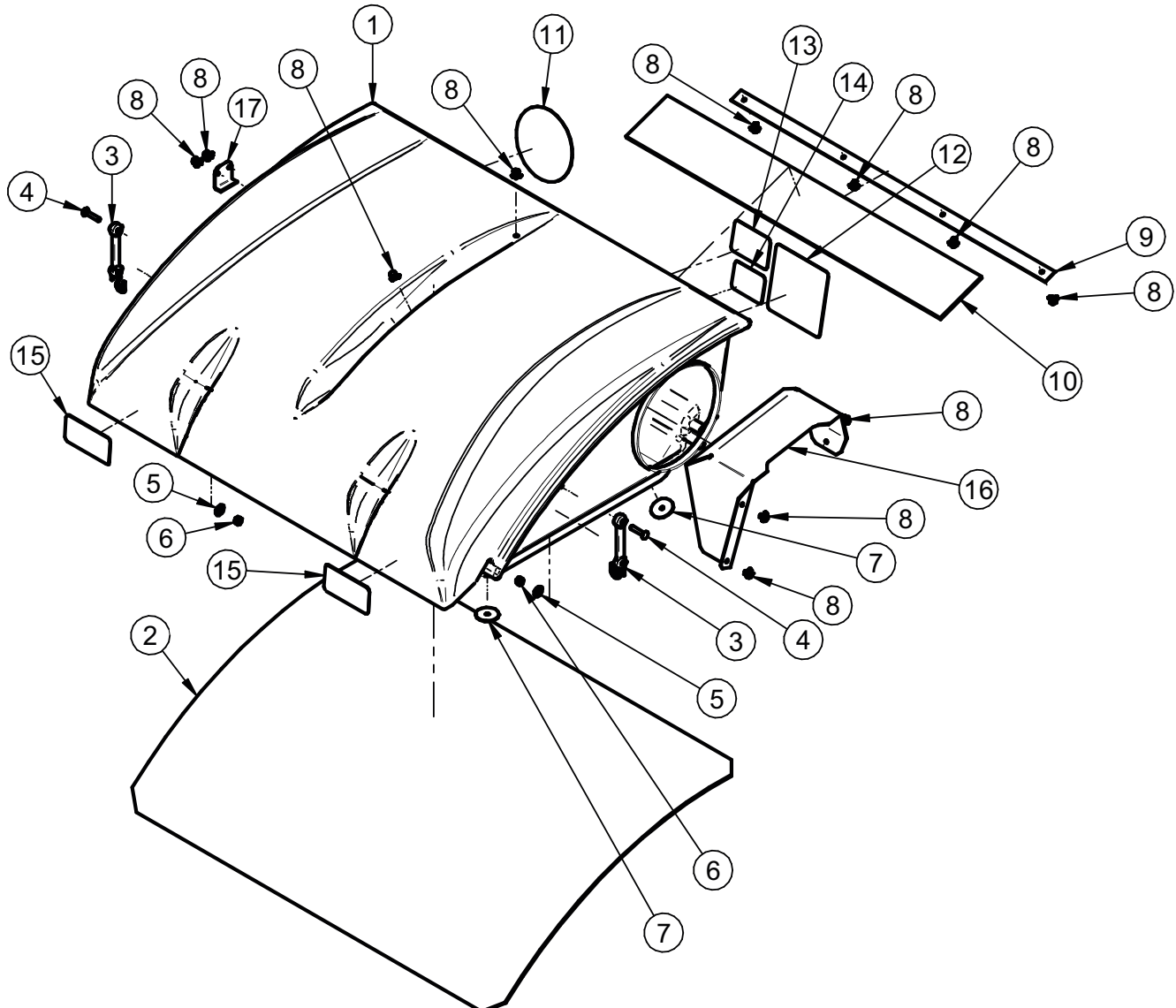

# A1158 Top Assembly Exploded Parts View

Item #	Part #	Desc.	Qty.
1	V0022	Pro 3 Bagger Top	1
2	C0069	Dust Guard Brace	1
3	K0114	Black Plastic Rivet	14
4	K1030	1/4"-20 x 1-1/4" Carriage Bolt	2
5	J4009	Short Rubber Strap w/ S-Hook	2
6	K0037	Flat Washer / 1/4" (.75 OD x .312 ID x .060 T)	2
7	K1128	1/4"-20 Nyloc Nut	2
8	C0026	Grass Deflector	1
9	K0062	Fender Washer / .230 ID x 1.500 OD / Zinc	4
10	V1120	Black Plastic Screen	1
11	V1118	Dust Guard	1
12	R1057	Decal / 2" x 4" Red Reflector	2
13	R1069	Decal / Warning - Turn Off Blower	1
14	R0022	Decal / Built In The USA / Lg	1
15	R1054	Decal / Important Check Hoses	1
16	R1051	Decal / Warning - Use Hearing Protection	1
17	B0676	Hinge Stop Pl.	1
18	K1265	Black Panel Retainer	3

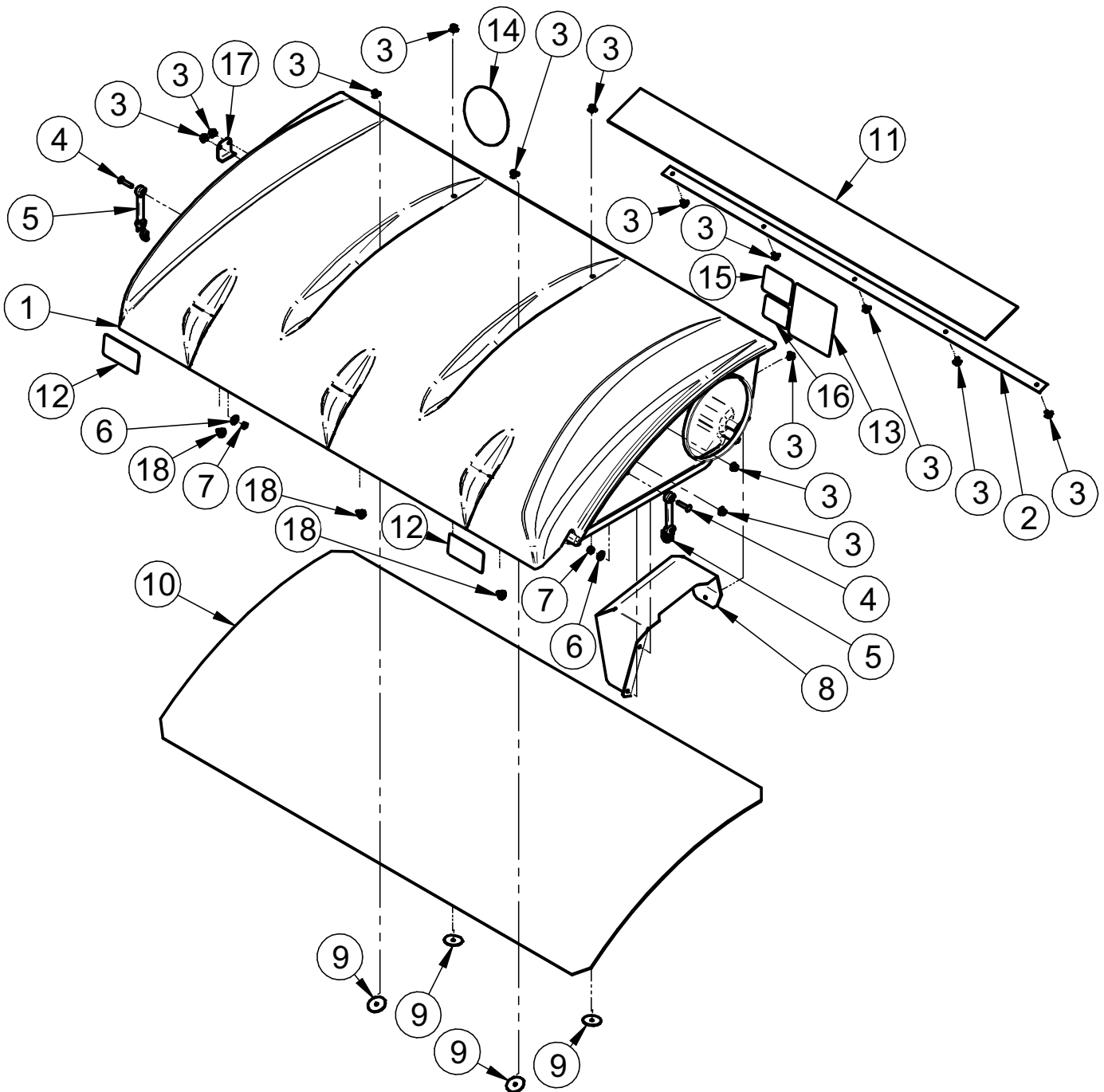

# Unit Model #: 38120905

**Mower:** Dixie Chopper BlackHawk/HP / Jacobsen ZI400 & ZI600

**Owner's Manual:** Q0515

**Mower Type:** 2248KW, 2548KOE, 2454KW, 2554BR, 2554KOE, 2460KW, 2560BR & 2560KOE

**Deck Size:** 48", 54" & 60"

**Vac Type:** 9 Cubic Foot Pro 2+ Bagger

**Deck Type:**

**Drive Type:** PTO Drive

**Revision #:**

**Fits Year(s):** 2016 & Newer

## A2132 Vac Kit

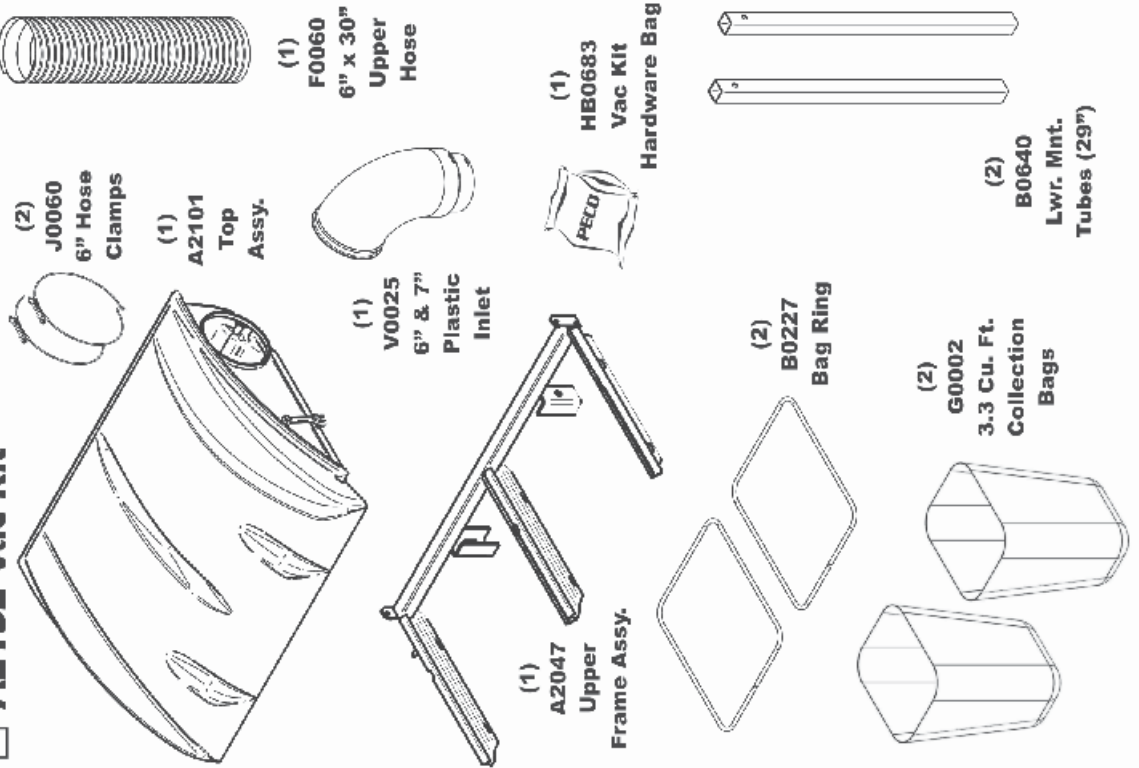

## A2134 Mount Kit

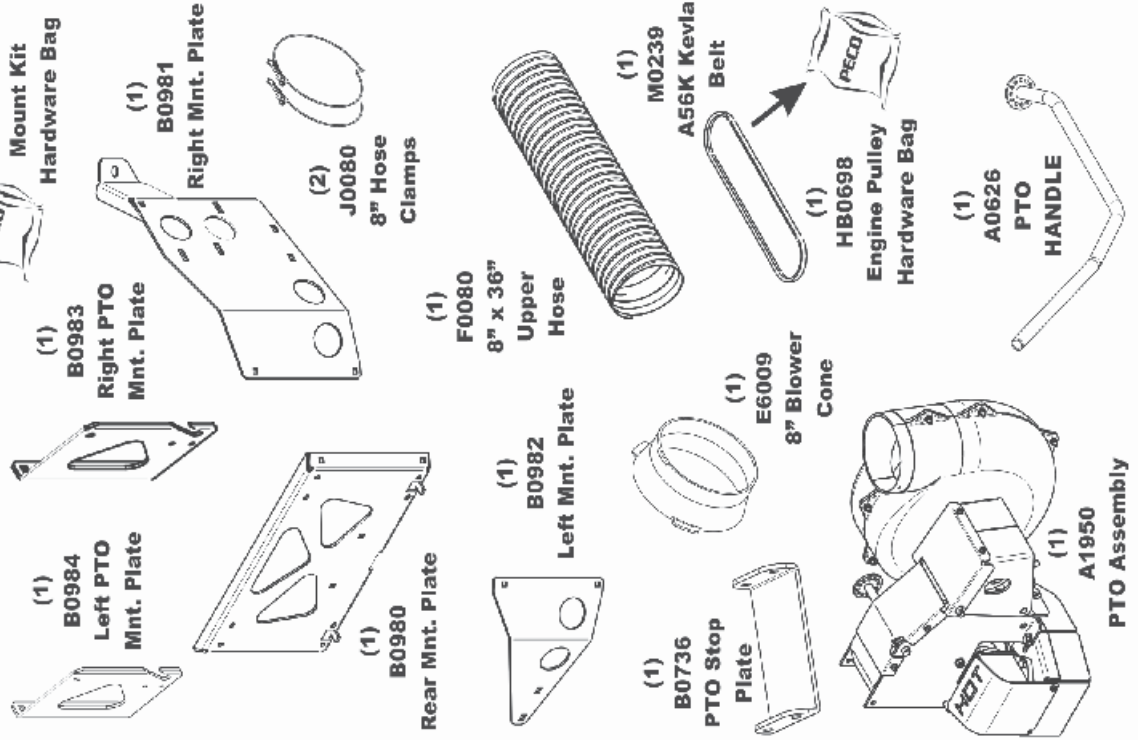

## A2130 Boot Kit

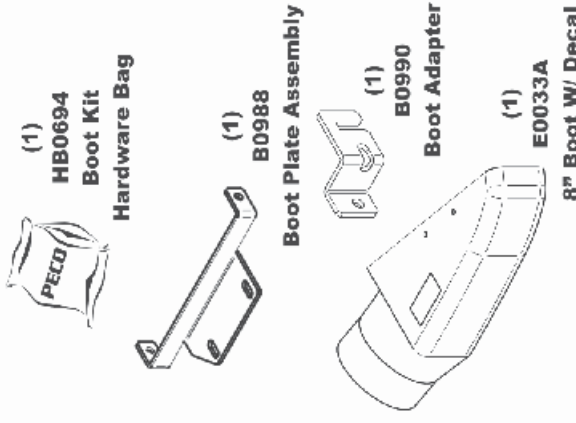

## A2131 Weight Kit

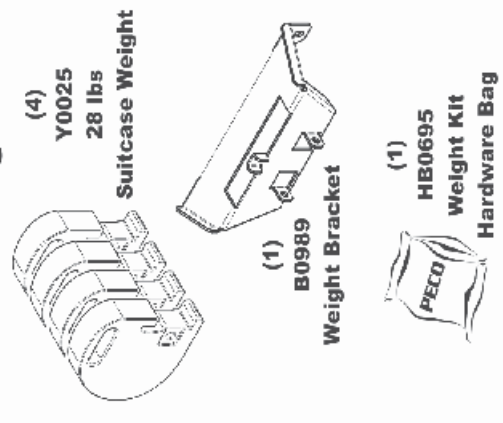



# Unit Model #: 38131508

Mower: Dixie Chopper BlackHawk HP / Jacobsen ZI600

Owner's Manual: Q0515

Mower Type: 2248KW, 2548KOE, 2454KW, 2554KOE, 2460KW & 2560KOE

Deck Size: 48" , 54" & 60"

Vac Type: 15 Cubic Foot Pro 3 Bagger

Deck Type:

Drive Type: PTO Drive

Revision #:

Fits Year(s): 2016 & Newer



## A2133 Vac Kit

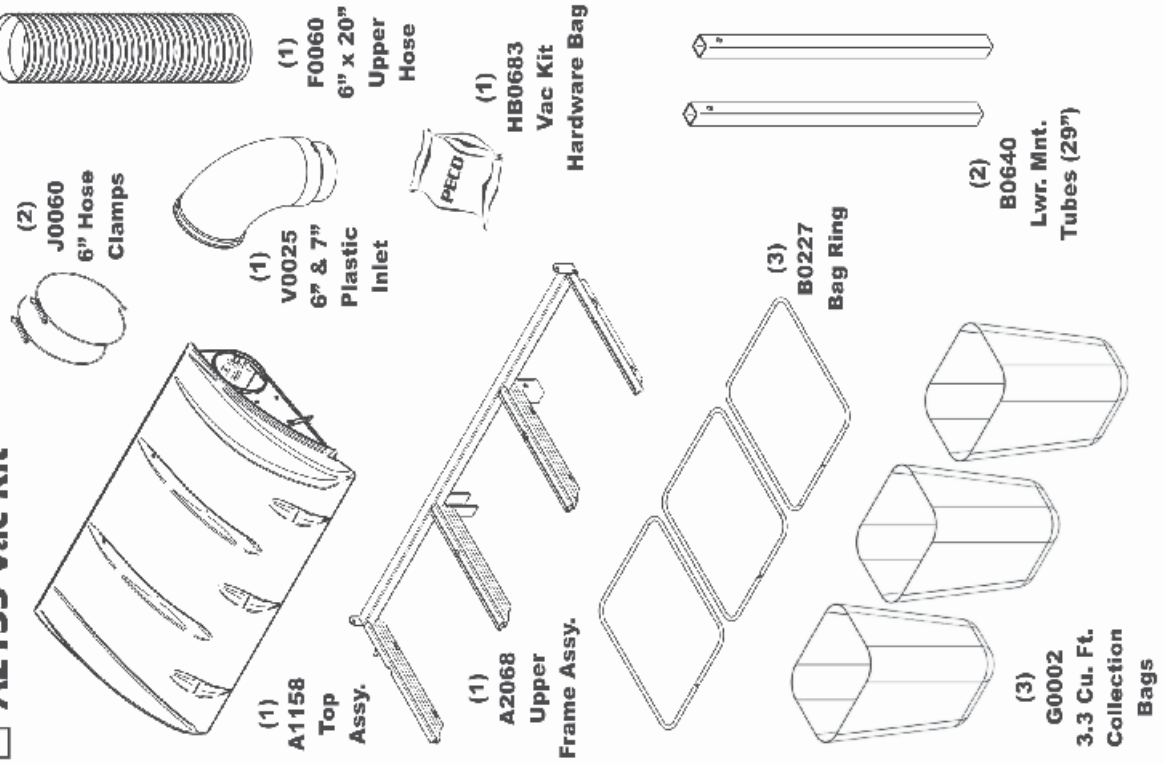

## A2134 Mount Kit

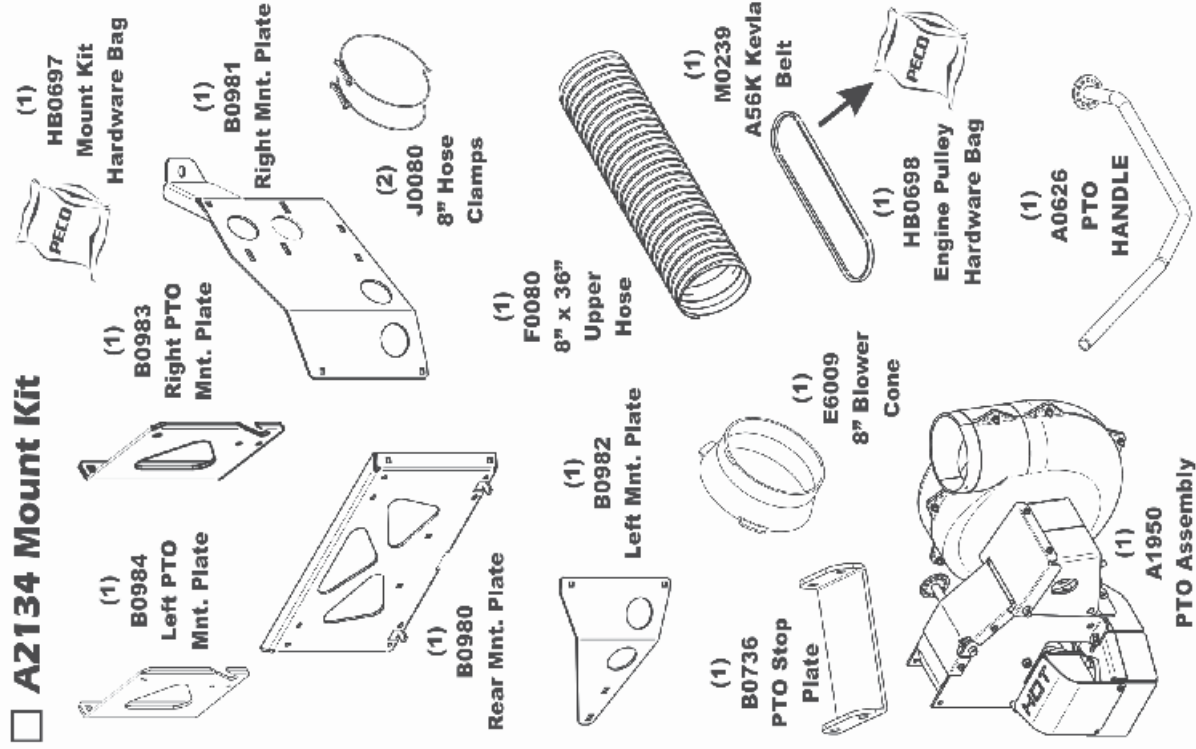

## A2130 Boot Kit

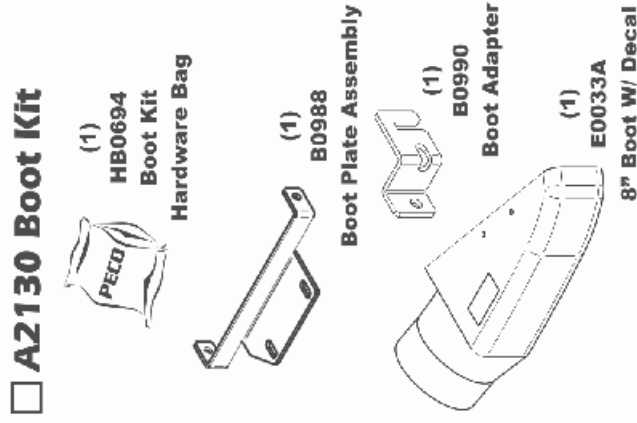

## A2131 Weight Kit

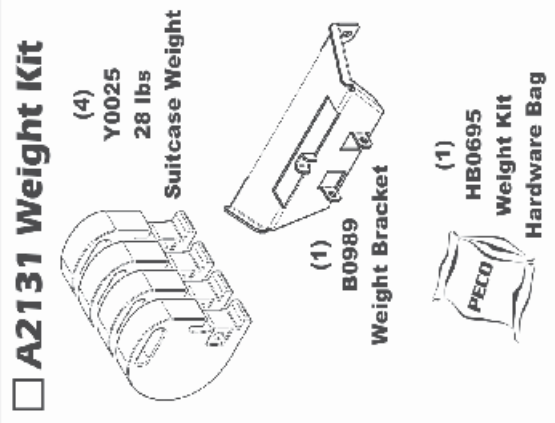

## SAFETY DECALS

To promote safe operation, New PECO, Inc. supplies safety decals on all products manufactured. Damage can occur to safety decals either through shipment, use or reconditioning. Contact your local Service Center for replacement decals.



Part# R1070  
PECO Logo



Part# R0022  
Designed & Built  
In The USA



Part #: R2007  
Danger - Never Use Hands



Part #: R2008  
Danger - Rotating Blades

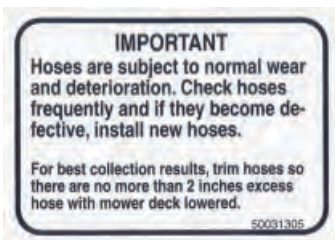

Part #: R1054  
Important - Hose Wear

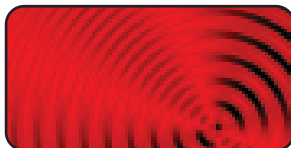
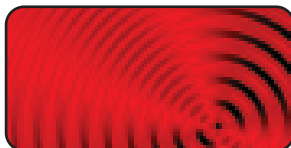

Part #: R1057 - (2)  
Red Reflectors



Part #: R1069  
Warning - Turn Off Blower



Part # R0024  
Danger - Keep Hands  
Clear



Part #: R1051  
Warning - Hearing Protection



Part # R0025  
Danger - Rotating  
Blades

## SECTION III OPERATING INSTRUCTIONS

### General Safety

Only qualified people familiar with this operator's manual and the mower's operator's manual should operate this machine.

### Operation And Tips On Mowing

- A. Perform BEFORE EACH USE the maintenance list referenced in Section IV.
- B. Start mower.
- C. With the mower at high idle speed, engage the mower deck.
- D. While seated in the operator's seat, move Bagger PTO switch to the on position. With the PTO assembly engaged, you can proceed to operate the control levers of the mower.

**NOTE:** If the collection system does not appear to be collecting the grass clippings, disengage the deck and PTO assembly, then, engage the parking brake and turn the mower off. Check upper and lower hoses for any clogs.

To obtain the maximum effectiveness from your collection system, the tips listed below should be followed:

- \* Watch your speed- Normal conditions will allow a speed of up to approximately 4 mph, but thick, heavy damp conditions will require reduced ground speed.
- \* Mow with sharp blades- A sharp blade cuts cleaner.
- \* Wet grass and leaves will decrease effectiveness and will increase horsepower requirements.
- \* Mow at higher cutting heights- Remove and mulch no more than 2" of grass length with each mowing. (Experts recommend not cutting off more than 1/3 of the grass blade length at any given time.)
- \* Mow twice, at different height settings, (high, then low), if grass is extra tall.
- \* Remember that horsepower requirements will vary with the mowing conditions such as type and height of turf grass, moisture content, amount of leaves, whether the terrain is flat or hilly, etc.

### Disengagement Of The PTO Assembly

- A. To disengage the PTO assembly, move Bagger PTO switch to the off position.

**WARNING:** The PTO assembly blades will continue to spin. DO NOT TOUCH the PTO assembly, pulleys, or the belt until the tractor is turned off. DO NOT adjust the belt tension until the mower is turned off. Refer to the Belt Installation section of the manual.

### Unloading The Collection System

**NOTE:** To determine when the collection bags are full, follow the following steps:

- A. Stop the forward movement of the mower.
- B. Disengage the mower deck.
- C. Disengage the PTO assembly.
- D. Engage the parking brake.
- E. Once the parking brake has been engaged, then and only then, walk behind the mower and check the collection bags by first unhooking the rubber strap with S-hook that secures the plastic top, then lift the plastic hood. Load in bags should not exceed the height of the installed bag.
- F. To remove the bags from the frame, slide bags out and turn bags over to deposit clippings.
- G. Slide empty bags back onto the frame and secure plastic top with the rubber strap with S-hook.

**NOTE:** Do not allow collection bags to become over-filled as potential damage may occur to your equipment. Also, be sure to clean the hood screen as needed.

## SECTION IV MAINTENANCE

### Maintenance Checklist

Before each use:

1. Check blades and spindles to be sure that no foreign objects, such as wire or steel strapping bands, are wrapped around them.
2. Inspect blades for wear. Replace if necessary. If it is necessary to sharpen the blades, remove the blades from the spindles before sharpening. DO NOT sharpen blades while still attached to the mower.

3. Make sure all shields are in place and in good condition. Repair or replace any missing or damaged shields.
4. Perform lubrication per instructions.
5. Listen for abnormal sounds, which might indicate loose parts, damaged bearings, or other damage. Correct any deficiency before continuing operation.
6. With the engine off, engage the blower assembly. Check the belt tension and inspect the pulley belt for cracks or tears.
7. Check for wear or deterioration of the upper or lower hoses. If there are any portions of the hose that have been torn or worn through, replace immediately.

After Each Use:

1. Clean all debris from machine especially from the container, underneath the belt shields, and safety decals. Replace any missing or illegible decals.
2. Inspect the unit for worn or damaged components. Repair or replace before the next use. Any replacement component installed during repair shall include the component's current safety decal specified by the manufacturers to be affixed to the component.
3. Under normal usage, the bag material is subject to deterioration and wear and should therefore be frequently checked for necessary replacement. Any replacement bag should be checked to ensure compliance with the original manufacturer's recommendations or specifications.
4. Check belt for proper tension.

## Lubrication

Gearbox:

1. Every 20 hours of use: Check oil levels in gearbox.
2. First 60 hours of use: Change oil.
3. Every 100 hours of use: Change oil.

**NOTE:** Oil in gearbox should cover the gears. If not, drain the gearbox and fill using an 80W-90 gear oil. The gearbox ships with 6.0 oz. of oil, but we recommend replacing with a measured 5.5 oz. to fill the gearbox. **DO NOT OVERFILL!**

Blower Assembly:

**NOTE:** The following is for older PTO models that contain a greaseable zerc fitting. Newer models contain maintenance-free bearings and are without a greasable fitting.

1. On initial use: Grease the fitting on the blower shaft.
2. Every 25 hours of use: Re-grease the grease fitting.

**NOTE:** Use only white lithium based grease for lubrication of the shaft on the blower assembly.

## SECTION V - PARTS & SERVICE

### Parts And Service Information

Collection system owners should record the name and telephone number of their Service Center. Your Service Center will be happy to supply replacement parts, accessories, and do any service or repairs to your collection system. If for any reason your Service Center is unable to service your collection system or supply replacement parts, contact New PECO, Inc. and include the following information on the chart below.

### DOCUMENT THE FOLLOWING INFORMATION FOR FUTURE REFERENCE

**Unit Model Number:** \_\_\_\_\_

**Unit Engine Size:** \_\_\_\_\_

**Unit Serial Number:** \_\_\_\_\_

**Date of purchase:** \_\_\_\_ / \_\_\_\_ / \_\_\_\_

**Dealer/Distributor Name:** \_\_\_\_\_

**Address:** \_\_\_\_\_ **State:** \_\_\_\_\_ **Zip:** \_\_\_\_\_

**Phone Number:** \_\_\_\_\_

**New PECO, Inc.**  
**10 Walden Dr | Arden, North Carolina 28704**  
**Phone: 1-800-438-5823 | 828-684-1234**  
**Fax: 828-684-0858**  
**Email: [peco@lawnvac.com](mailto:peco@lawnvac.com)**  
**Website: [www.lawnvac.com](http://www.lawnvac.com)**

# TORQUE SPECIFICATIONS

Proper torque for American fasteners used on Peco equipment.  
Recommended Torque in Foot Pounds (Newton Meters).\*

## AMERICAN Bolt Head Markings

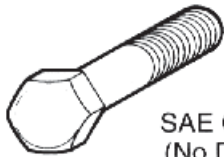

SAE Grade 2  
(No Dashes)

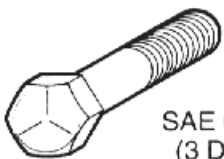

SAE Grade 5  
(3 Dashes)

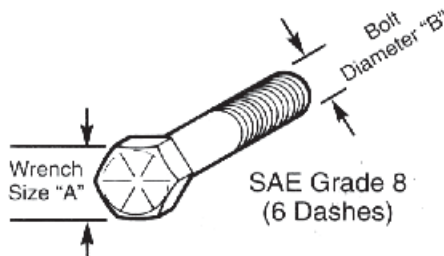

SAE Grade 8  
(6 Dashes)

WRENCH SIZE (IN.) "A"	BOLT DIAMETER (IN.) "B" AND THREAD SIZE	SAE GRADE 2	SAE GRADE 5	SAE GRADE 8
7/16	1/4 - 20 UNC	6 (7)	8 (11)	12 (16)
7/16	1/4 - 28 UNF	6 (8)	10 (13)	14 (18)
1/2	5/16 - 18 UNC	11 (15)	17 (23)	25 (33)
1/2	5/16 - 24 UNF	13 (17)	19 (26)	27 (37)
9/16	3/8 - 16 UNC	20 (27)	31 (42)	44 (60)
9/16	3/8 - 24 UNF	23 (31)	35 (47)	49 (66)
5/8	7/16 - 14 UNC	32 (43)	49 (66)	70 (95)
5/8	7/16 - 20 UNF	36 (49)	55 (75)	78 (106)
3/4	1/2 - 13 UNC	49 (66)	76 (103)	106 (144)
3/4	1/2 - 20 UNF	55 (75)	85 (115)	120 (163)
7/8	9/16 - 12 UNC	70 (95)	109 (148)	153 (207)
7/8	9/16 - 18 UNF	79 (107)	122 (165)	172 (233)
15/16	5/8 - 11 UNC	97 (131)	150 (203)	212 (287)
15/16	5/8 - 18 UNF	110 (149)	170 (230)	240 (325)
1-1/8	3/4 - 10 UNC	144 (195)	266 (360)	376 (509)
1-1/8	3/4 - 16 UNF	192 (260)	297 (402)	420 (569)
1-5/16	7/8 - 9 UNC	166 (225)	430 (583)	606 (821)
1-5/16	7/8 - 14 UNF	184 (249)	474 (642)	668 (905)
1-1/2	1 - 8 UNC	250 (339)	644 (873)	909 (1232)
1-1/2	1 - 12 UNF	274 (371)	705 (955)	995 (1348)
1-1/2	1 - 14 UNF	280 (379)	721 (977)	1019 (1381)
1-11/16	1-1/8 - 7 UNC	354 (480)	795 (1077)	1288(1745)
1-11/16	1-1/8 - 12 UNF	397 (538)	890 (1206)	1444 (1957)
1-7/8	1-1/4 - 7 UNC	500 (678)	1120 (1518)	1817 (2462)
1-7/8	1-1/4 - 12 UNF	553 (749)	1241 (1682)	2013 (2728)
2-1/16	1-3/8 - 6 UNC	655 (887)	1470 (1992)	2382 (3228)
2-1/16	1-3/8 - 12 UNF	746 (1011)	1672 (2266)	2712 (3675)
2-1/4	1-1/2 - 6 UNC	870 (1179)	1950 (2642)	3161 (4283)
2-1/4	1-1/2 - 12 UNF	979 (1327)	2194 (2973)	3557 (4820)

## METRIC

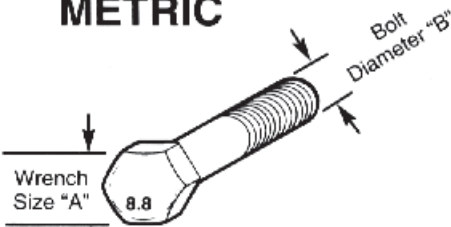

Numbers appearing on bolt heads indicate ASTM class.

Proper torque for metric fasteners used on Peco equipment.  
Recommended torque in foot pounds (newton Meters).\*

WRENCH SIZE (mm) "A"	BOLT DIA. (mm) "B"	ASTM 4.6	ASTM 8.8	ASTM 9.8	ASTM 10.9
8	5	1.8 (2.4)		5.1 (6.9)	6.5 (8.8)
10	6	3 (4)		8.7 (12)	11.1 (15)
13	8	7.3 (10)		21.1 (29)	27 (37)
16	10	14.5 (20)		42 (57)	53 (72)
18	12	25 (34)	74 (100)	73 (99)	93 (126)
21	14	40 (54)	118 (160)	116 (157)	148 (201)
24	16	62 (84)	167 (226)	181 (245)	230 (312)
30	20	122 (165)	325 (440)		449 (608)
33	22		443 (600)		611 (828)
36	24	211 (286)	563 (763)		778 (1054)
41	27		821 (1112)		1138 (1542)
46	30	418 (566)	1119 (1516)		1547 (2096)

\*Use 75% of the specified torque value for plated fasteners. Use 85% of the specified torque values for lubricated fasteners.

# Troubleshooting

2017 (v1.0)

## Collection System Performance

<b>Problem</b>	<b>Possible Cause</b>	<b>Corrective Action</b>
Abnormal Vibration	<ul style="list-style-type: none"> <li>• Cutting blades are bent or unbalanced</li> <li>• Loose blower pulley or pulley assembly</li> <li>• Impeller blade out of balance</li> </ul>	<ul style="list-style-type: none"> <li>• Install new cutting blade</li> <li>• Tighten the pulley</li> <li>• Contact dealer to replace</li> </ul>
Reduced collection system performance	<ul style="list-style-type: none"> <li>• Low engine speed</li> <li>• Plugged screen</li> <li>• Loose belt</li> <li>• Full collection bags</li> </ul>	<ul style="list-style-type: none"> <li>• Always operate collection system at full throttle</li> <li>• Remove debris, leaves, or grass clippings from the screen</li> <li>• Replace/tighten belt</li> <li>• Empty the collection bags</li> </ul>
Blower and hoses plugging too frequently	<ul style="list-style-type: none"> <li>• Collection bags are too full</li> <li>• Low engine speed</li> <li>• Grass is too wet</li> <li>• Grass is too long</li> <li>• Ground speed is too fast</li> <li>• Worn belt</li> <li>• Loose belt</li> </ul>	<ul style="list-style-type: none"> <li>• Dump more frequently</li> <li>• Always operate collection system at full throttle</li> <li>• Cut grass when it is dry</li> <li>• Cut the grass several times</li> <li>• Drive slower at full throttle</li> <li>• Replace belt</li> <li>• Adjust the pulley and tighten belts</li> </ul>
Debris blowout	<ul style="list-style-type: none"> <li>• Collection bags are too full</li> <li>• Plug/clog in the collection system</li> <li>• Ground speed is too fast</li> </ul>	<ul style="list-style-type: none"> <li>• Dump more frequently</li> <li>• Clean the collection system</li> <li>• Drive more slowly at full throttle</li> </ul>
Impeller doesn't rotate freely	<ul style="list-style-type: none"> <li>• Plug in the blower housing</li> <li>• Worn impeller blade</li> <li>• Shaft bearings bad/failing</li> </ul>	<ul style="list-style-type: none"> <li>• Clean the blower housing</li> <li>• Contact dealer to replace</li> <li>• Contact dealer to replace</li> </ul>

## NOTES



**New PECO, Inc.**  
**10 Walden Dr | Arden, North Carolina 28704**  
**Phone: 1-800-438-5823 | 828-684-1234**  
**Fax: 828-684-0858**  
**Email: [peco@lawnvac.com](mailto:peco@lawnvac.com)**  
**Website: [www.lawnvac.com](http://www.lawnvac.com)**