

# DIXIE CHOPPER.

# XT3

COLLECTION SYSTEM

**Unit Model #: 38131501**

**Mower:** Dixie Chopper

**Owner's Manual:** Q0451

**Mower Type:** Silver Eagle

**Engine Type:** Fits All Engine Models

**Deck Size:** 44", 50" and 60"

**Vac Type:** 15 Cu. Ft. Pro 3 Bagger

**Deck Type:**

**Drive Type:** Briggs & Stratton 6.5HP Vanguard

**Revision #:** Final Release 2/20/13

**Fits Year(s):** 2011 - 2014

**A1891 Vac Kit**

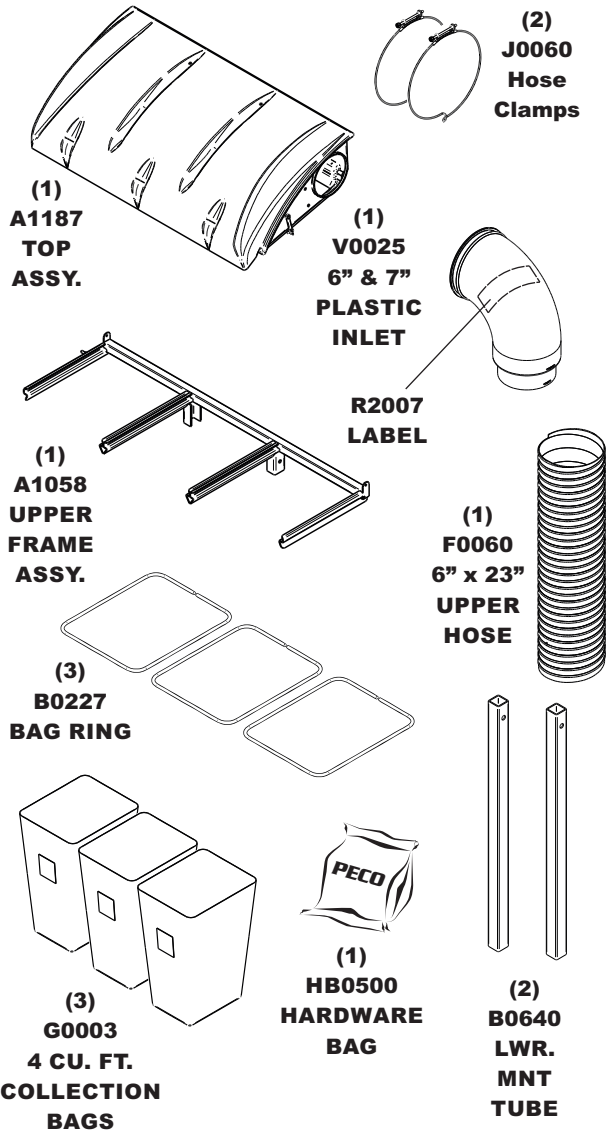

**A1892 Mount Kit**

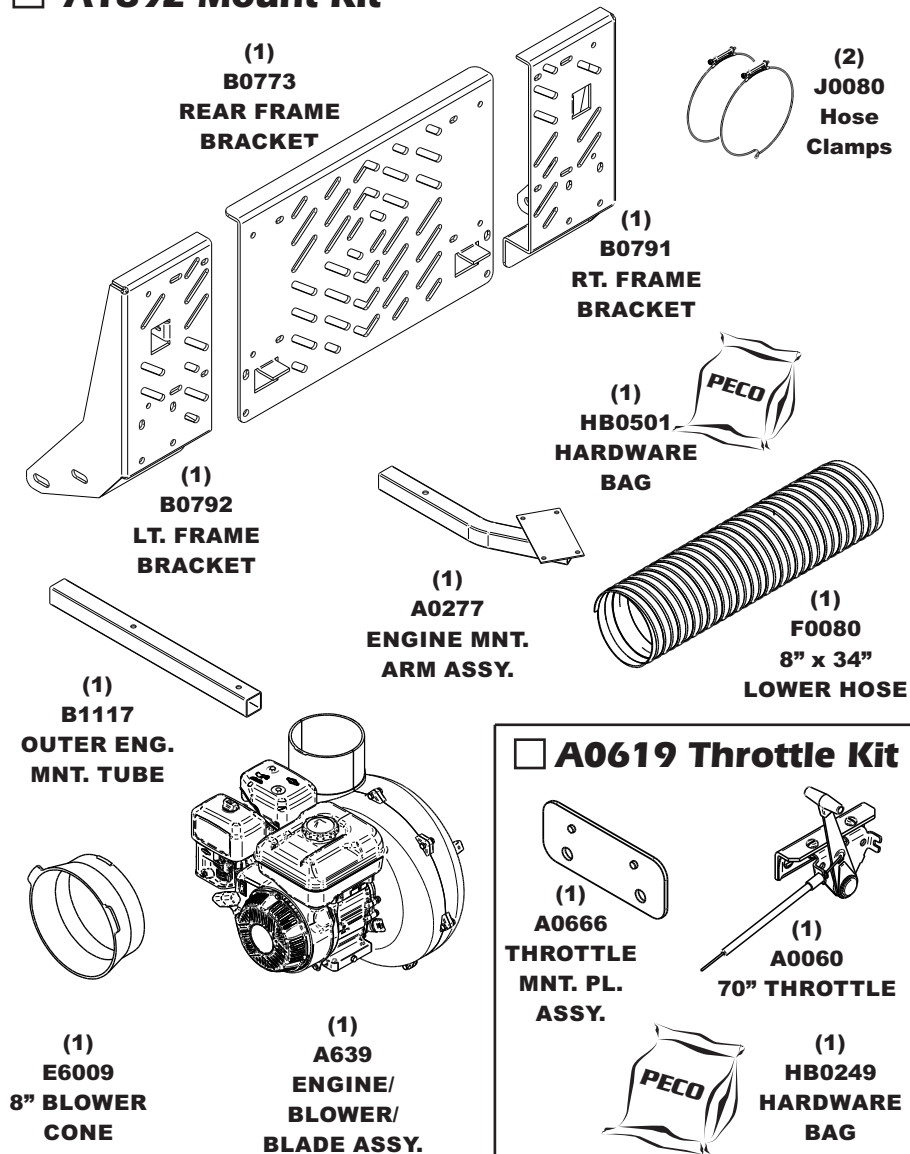

**A0619 Throttle Kit**

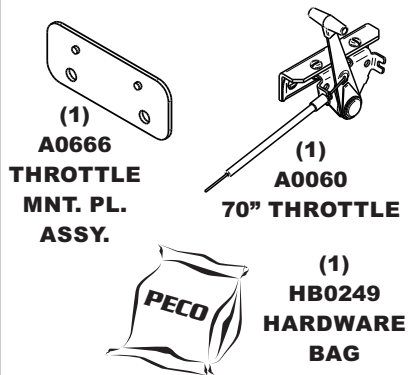

**A1880 Boot Kit**

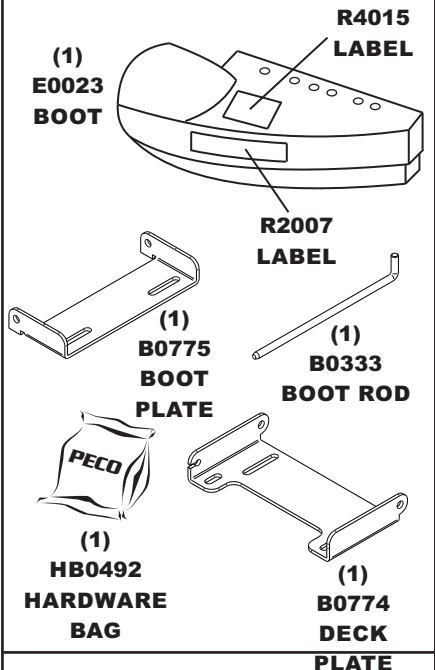

**A1879 Weight Kit**

