

# DIXIE CHOPPER<sup>®</sup>

# XT12

COLLECTION SYSTEM

**Unit Model #: 38621236**

**Mower:** Dixie Chopper

**Owner's Manual:** Q0455

**Mower Type:** Classic T/W 2750, 2760, 3360 & 3560

**Engine Type:** 27HP & 35HP KW & 33HP Gen.

**Deck Size:** 50" and 60"

**Vac Type:** 12 Cu. Ft. Pro 12 DFS

**Deck Type:** X2 Cutting System

**Drive Type:** PTO Driven

**Revision #:** Final Release 3/7/13

**Fits Year(s):** 2012-2013

**A1898 Vac Kit**

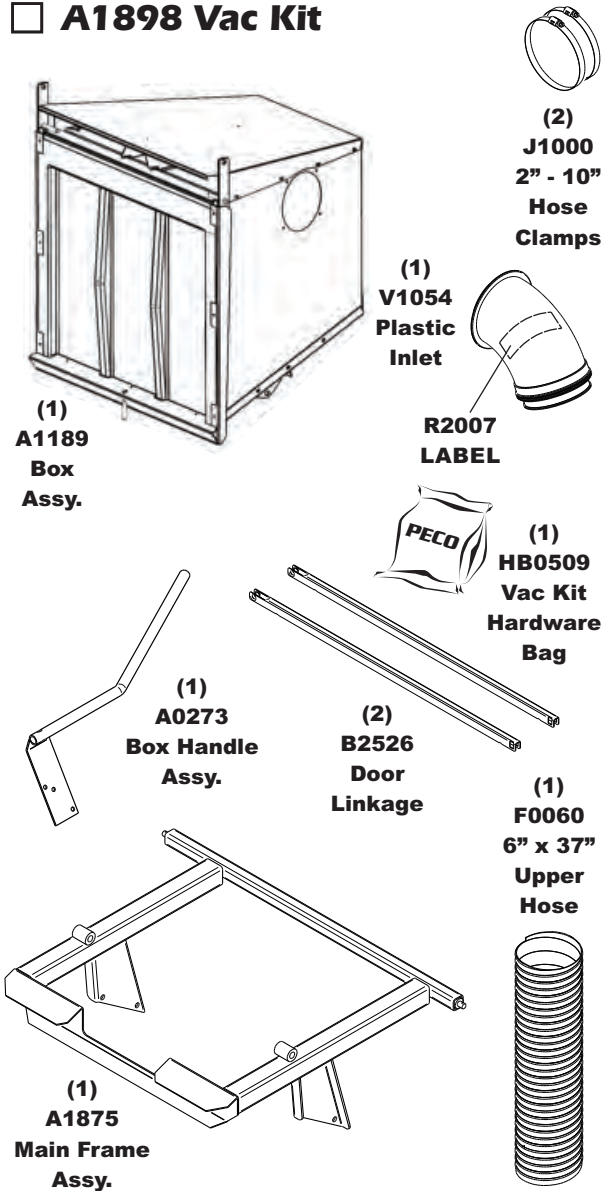

**A1897 Mount Kit**

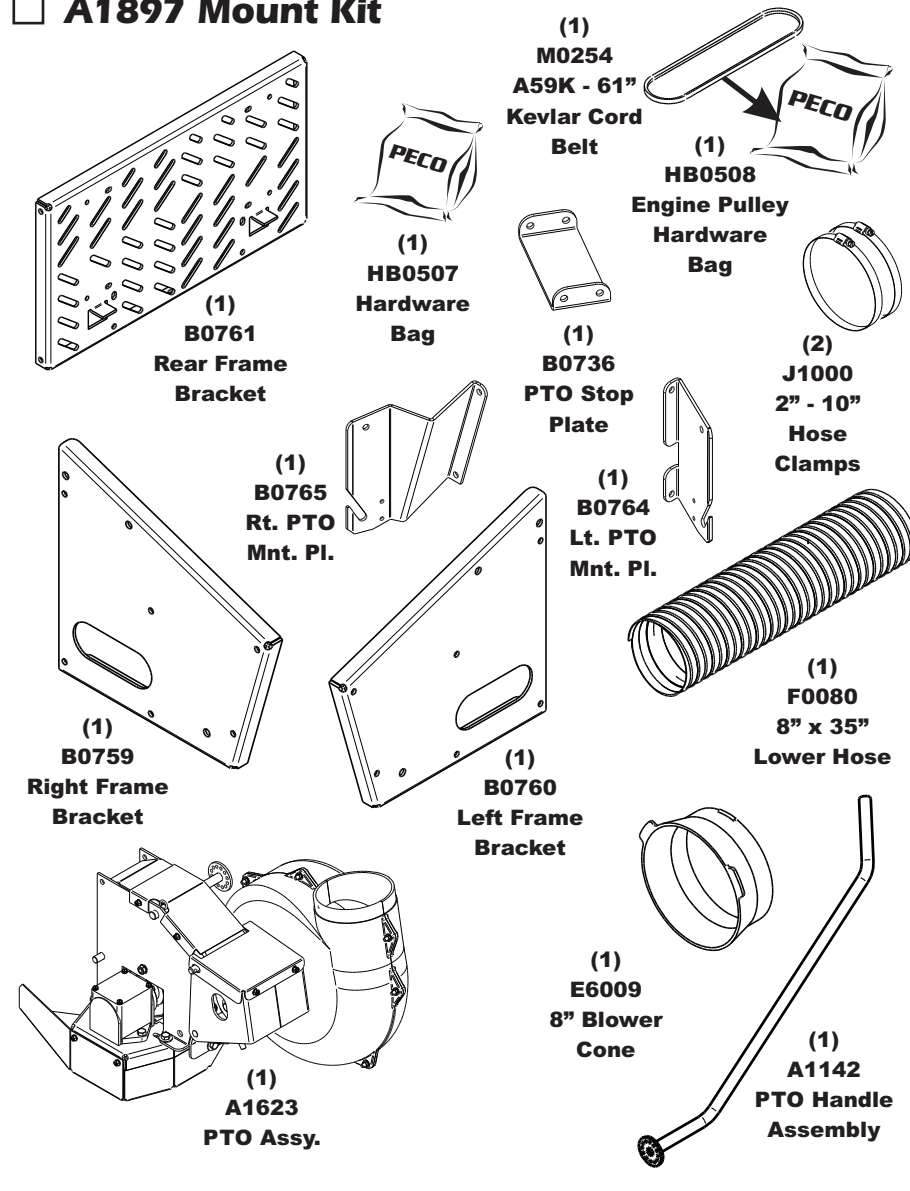

**A1880 Boot Kit**

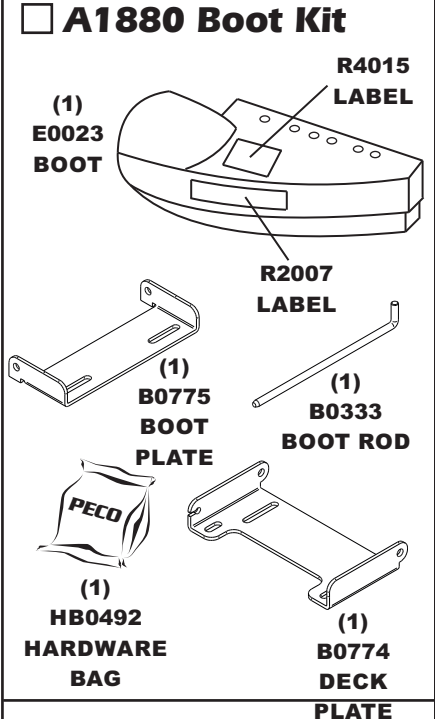

**A1879 Weight Kit**

