

Cub Cadet®

PTO DRIVEN - GRASS

MODEL YEAR:

2014-2015

COLLECTION SYSTEM

DESIGNED
TO FIT:

TANK SERIES

S

- 60"
DECKS

SZ

- 54" & 60"
DECKS

L

- 48", 54" & 60"
DECKS

LZ

- 54" & 60"
DECKS

COLLECTION SYSTEM

MODEL # 59A30044150

ALTERNATE
MODEL # 21131508

Tank S Models:
53RN2RUD050

Tank L Models:
53AN2RTB050

Tank SZ Models:

53AI2RTC050
53AN2RTD050
53AI2RTD050
53AN2RTD009
53YI2RTD050

53AI2PUC050
53BI2PUD050
53YI2PUC050
53YI2PUD050
53RE2PUD050
53AI2PUD330

Tank LZ Models:

53AI2PTC050
53BI2PTD050
53YI2PTC050
53YI2PTD050
53BH2PTD330



***LZ MODELS: COLLECTION SYSTEM REQUIRES INSTALLATION
OF ADDED WEIGHT KIT P# 59A30037150 (A1149) FOR SAFE OPERATION!**

OPERATOR'S MANUAL

ASSEMBLY • OPERATION • MAINTENANCE

PECO GRASS COLLECTION SYSTEM

TABLE OF CONTENTS

SECTION	PAGE	SECTION	PAGE
Safety	2	2-14 Length Of Hose Adjustment	15
Safety Alert Symbols	3	2-15 Upper Hose Installation	15
Warranty	4	2-16 Lower Hose To Blower Cone Installation	15
I INTRODUCTION AND DESCRIPTION	5	2-17 Lower Hose To Boot Installation	16
1-1 Introduction	5	2-18 Impeller Blade Removal/Replacement	16
1-2 Description	5	2-19 Weight Kit Installation	17
II INSTALLATION FOR USE	6	2-20 Installation/Removal of Collection Bags	18
2-1 Preparation Of Mower	6	Exploded Part Views and Assemblies	19-22
2-2 PTO Mount Plate Assembly Installation	7	Safety Interlock Harness Wiring Schematic	23
2-3 Lower Mount Assembly Installation	7	III OPERATING INSTRUCTIONS	24
2-4 PTO Assembly Installation	8	3-1 General Safety	24
2-5 Drive Belt Installation and Adjustment	9	3-2 Operation & Tips On Mowing	24
2-6 Cam Assembly Adjustment	10	3-3 Disengagement Of The Blower	24
2-7 Blower Cone Installation	10	3-4 Unloading The Collection System	24
2-8 Safety Interlock Harness Installation	11	IV MAINTENANCE	24
2-9 Lower Mount Tube Installation	12	4-1 Maintenance Checklist	24-25
2-10 Upper Frame Assembly Installation	12	4-2 Lubrication	25
2-11 Top Assembly To Upper Frame Assembly Installation	13	V PARTS AND SERVICE	25
2-12 Hinge Kit Installation	13	5-1 Parts And Service Information	25
2-13 Boot To Mower Deck Installation	14	Safety Decals	26
		Torque Specifications	27

Safety

1. Read the operator's manual carefully and familiarize yourself with the proper use of your attachment. Do not allow anyone who is not acquainted with the Safety Instructions to use your attachment.
2. Know the controls and how to stop quickly. READ THE OPERATOR'S MANUAL!
3. Do not allow children to operate the vehicle. Do not allow adults to operate it without proper instruction.
4. Be especially watchful of children and pets darting into the area while operating.
5. Keep your eyes and mind on your unit while mowing or operating your attachment. Don't let others distract you.
6. Do not attempt to operate your unit or mower when not in the driver's seat.
7. Always stop unit when emptying the container.
8. Stop unit, shut off deck attachment, set parking brake, shut off mower engine and remove spark plug wire before removing clogs, removing or replacing hose, boot, blower cone, or performing any maintenance.
9. Mow across the face of slopes (not steeper than 10 degrees); never up and down the face.
10. It is recommended that the container be kept only half full when negotiating any slopes. Start mowing on slopes when the container is empty.
11. Inspect your lawn and remove any foreign objects before mowing. Never deliberately run the mower across any foreign object.
12. Wear ear protection if the noise level is offensive.
13. Wear eye protection to prevent debris from damaging your eyes.

SAFETY

WARNING! **NEVER** operate the mower unless the discharge guard and either the deflector assembly or the vacuum collector adapter are fastened securely in place.

WARNING! Do not work around the mower deck boot or the blower area until you are certain that the mower blades and the blower impeller have stopped rotating.

WARNING! To avoid serious injury, perform maintenance on the vacuum collector; **ONLY AFTER STOPPING THE MOWER'S ENGINE AND WAITING FOR ALL MOVING PARTS TO COME TO A COMPLETE STOP.** Set the parking brake. Always remove the ignition key before beginning maintenance.

WARNING! For your own personal safety, **ALWAYS** mow **ACROSS** the face of slopes and **NEVER UP and DOWN** the face. **NEVER** attempt to mow excessively steep slopes, and use caution when turning on any slope.

Safety Alert Symbol



This Safety Alert Symbol means: **“ATTENTION! BECOME ALERT! YOUR SAFETY IS INVOLVED!”**

This symbol is used to call attention to safety precautions that should be followed by the operator to avoid accidents. When you see this symbol, carefully read the message that follows and heed its advice. Failure to comply with safety precautions could result in death or serious bodily injury.

Safety Signs

The signal words **DANGER**, **WARNING**, and **CAUTION** are used on the equipment safety signs. These words are intended to alert the viewer to the existence and the degree of hazard seriousness.



White letters on **RED**

This signal word indicates a potentially hazardous situation which, if not avoided, will result in death or serious injury.



Black letters on **ORANGE**

This signal word indicates a potentially hazardous situation which, if not avoided, could result in death or serious injury.

It may also be used to alert against unsafe practices.



Black letters on **YELLOW**

This signal word indicates a potentially hazardous situation exist which, if not avoided, will result in minor or moderate injury.

It may also be used to alert against unsafe practices.

PECO LIMITED WARRANTY FOR NEW PRODUCTS

A. WHAT IS UNDER WARRANTY?

PECO extends the following warranties to the original purchaser of each new PECO consumer product subject to the following limitations.

1. PRODUCT WARRANTY: Any part of any consumer product, which is defective in material or workmanship as delivered to the purchaser will be repaired or replaced, as PECO elects, without charge for parts or labor, if the defect appears within 12 months from the date of delivery of the product to the original purchaser.

ALL DEFECTIVE PARTS MUST BE RETURNED TO PECO FOR INSPECTION TO DETERMINE VALIDITY OF WARRANTY CLAIMS. Freight and mailing will be borne by the customer.

2. PARTS REPLACED DURING WARRANTY: Any new PECO part which is furnished in performance of this warranty and is defective in material or workmanship as delivered to the purchaser will be repaired or replaced, as PECO elects, without charge if the defect appears within 90 days from the date of installation of such part or before the expiration of the original warranty period, whichever is later.

B. SECURING WARRANTY ADJUSTMENTS.

Call PECO for Return Authorization. Damaged or broken parts other than engines or batteries, must be returned to New PECO, Inc. 100 Airport Road, Arden, NC 28704 before any warranty adjustment can be authorized. At the time of requesting warranty adjustment, the purchaser must present evidence of the date of delivery of the product. The purchaser shall pay any charge for the product to and from Arden, NC.

C. ITEMS NOT COVERED BY PECO WARRANTY.

Engines and batteries attached to PECO products are covered under a separate warranty by the respective manufacturer.

D. UNAPPROVED ALTERATION OR MODIFICATION.

All obligations of New PECO, Inc. under this warranty shall be terminated if products are altered or modified in ways not approved by New PECO, Inc.

E. ACCIDENTS AND NORMAL MAINTENANCE.

The warranty covers only defective material and workmanship. It does not cover depreciation or damage caused by normal wear, accident, improper use or abuse of products. The cost of normal maintenance and normal replacement of service items such as belts, cutting blades, hoses, etc., which are not defective shall be paid for by the purchaser.

F. NO REPRESENTATIONS ADDITIONAL WARRANTIES, DISCLAIMER.

Neither New PECO, Inc. nor any company affiliated with it makes any warranties, representations or promises as to the quality of performance of its products other than those set forth herein. Except as described above, New PECO, Inc. makes no other warranties **AND SPECIFICALLY DISCLAIMS ANY AND ALL IMPLIED WARRANTIES OF FITNESS AND MERCHANTABILITY.**

G. ANY MACHINE USED FOR RENTAL PURPOSES ARE GUARANTEED FOR 45 DAYS FROM DATE OF ORIGINAL SALE ONLY.

H. REMEDIED EXCLUSIVE.

The only remedies the purchaser has in connection with the breach or performance of any warranty on New PECO, Inc. consumer products are set forth above. In no event will PECO be liable for special incidental or consequential damages.

1. NO SERVICE CENTER WARRANTY.

The selling Service Center makes no warranty on his own on any item warranted by New PECO, Inc. unless he delivers to purchaser a separate written warranty certificate specifically warranting the item. The dealer has no authority to make any representation or promise on behalf of PECO or to modify the terms of this warranty in any way.

Section I - INTRODUCTION AND DESCRIPTION

1-1 Introduction

We are pleased to have you as a PECO customer. Your collection system has been designed to give you a low maintenance, simple, and effective way to collect the grass clippings from your mower. This manual is provided to give you the necessary instructions to properly mount and operate the collection system on your mower. Please read this manual thoroughly. Understand what each control is for and how to use it. Observe all safety decal precautions on the machine and noted throughout the manual.

NOTE: all references made to right, left, front, rear, top or bottom are as viewed from the normal operator's position on the mower.

1-2 Description

The grass collection system is designed for turf maintenance where there is a need to collect the grass clippings as the mower cuts the turf. It is also used for picking up leaves and in pre-season and post-season clean-up. The blower, mounted on the right side of the unit, uses a belt and gearbox system from the engine PTO shaft. Drive train protection comes through belt slippage. The blower draws grass clippings from the discharge area of the cutter deck back to the (3) - 4 cubic foot collection bags P#(G0003) at the rear portion of the mower frame. The operator can engage the blower with a push of the over-center linkage on the right side of the unit. Once the bags are full with clippings, they can be released to make for easy dumping.

LZ Models: Collection system requires installation of added weight kit 59A30037150 (A1149) for safe operation! SZ models do not require a weight kit. Refer to Section 2-21 in this manual for weight kit installation instructions. Contact your Cub Cadet dealer to order weight kit 59A30037150 (A1149).



Section II - INSTALLATION FOR USE

2-1 Preparation Of Mower

NOTE: The mower deck PTO belt must be removed from the electric clutch before continuing with the installation. Refer to your Cub Cadet mower owner's manual for instructions on PTO belt removal.

From the underside of the engine, disconnect the wiring harness attached to the electric clutch. Remove the bolt and electric clutch from the mower. Refer to Figure 2-1a.

Figure 2-1a

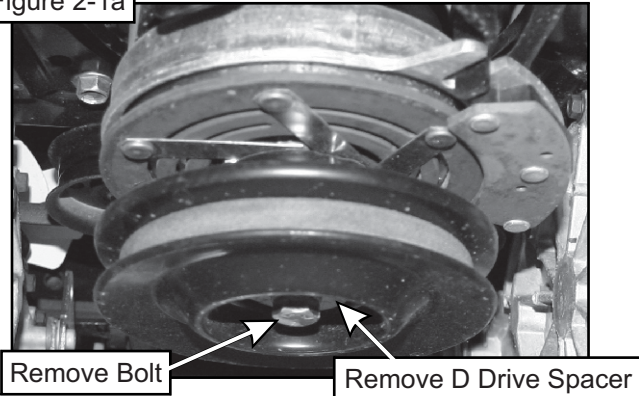

Remove the D-drive spacer using an arbor press or equivalent. On removal, adjacent bearing OUTER race must be supported or bearing damage may occur. Refer to Figure 2-1b.

Figure 2-1b

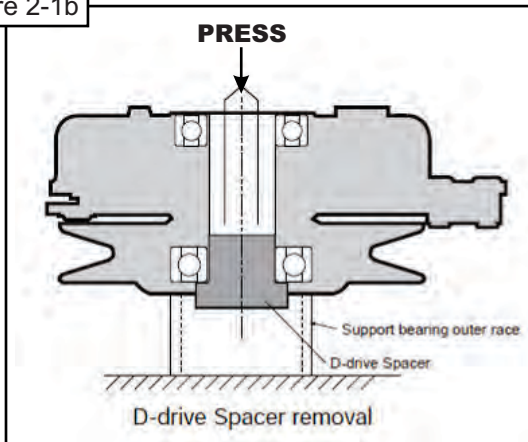
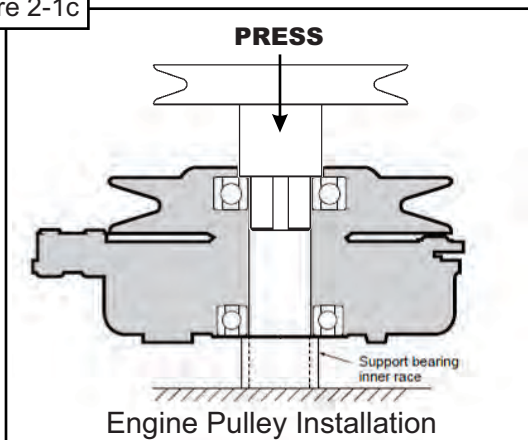

Figure 2-1c



The engine pulley assembly must be installed using an arbor press or equivalent. During installation, opposite bearing inner race must be supported or bearing damage may occur. Refer to Figure 2-1c.

Upon pressing the engine pulley to the clutch, replace the completed assembly to the mower's engine shaft to fasten.

Figure 2-1d

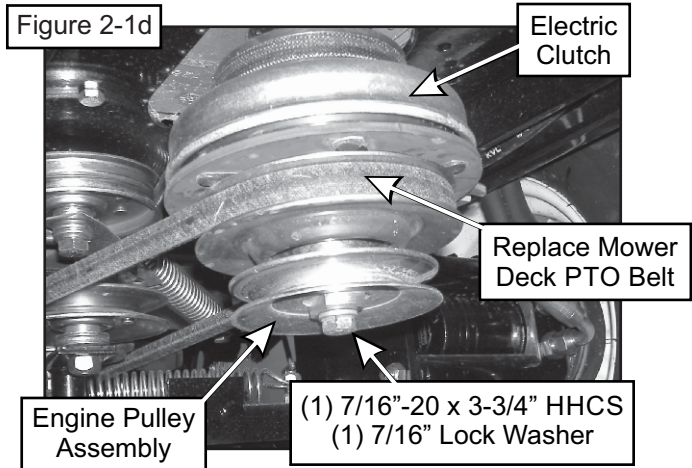

Fasten engine pulley assembly number 18 P#(A1109) to the electric clutch using (1) 7/16"-20 x 3-3/4" HHCS P#(K0350) and (1) 7/16" helical spring lock washer P#(K0140). Torque the bolt to 55ft./lbs. Refer to Figure 2-1d for reference.

NOTE: Replace the mower deck PTO belt removed at the beginning of this section.

Remove the rear bumper and hardware from the mower as shown in Figure 2-1e.

Figure 2-1e

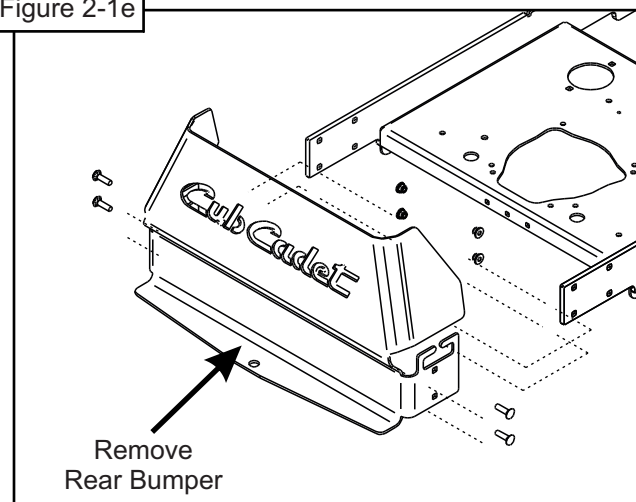

2-2 PTO Mount Plate Assembly Installation

Secure the PTO mount plate assembly P#(A1108) to the chassis of the mower using (4) 3/8"-16 x 1" carriage bolts P#(K1182) and (4) 3/8-16 nylon flange locknuts P#(K2038). Leave the hardware loose until the lower mount assembly is installed in the next section. Refer to Figure 2-2.

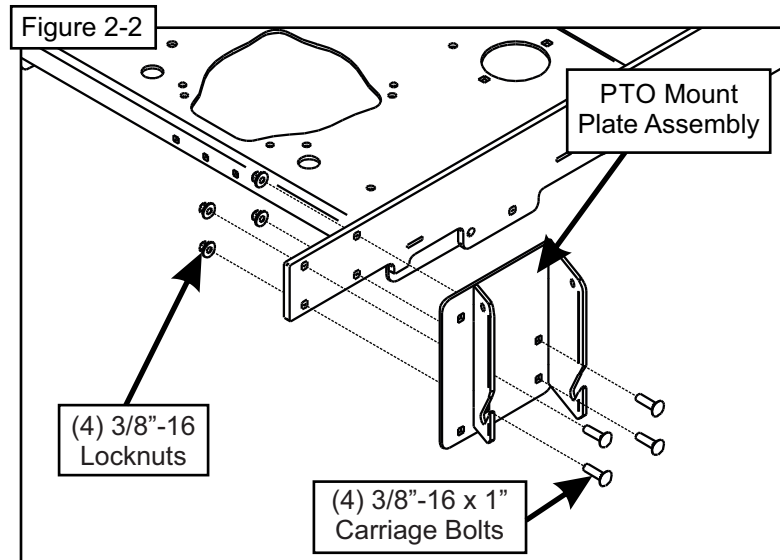

2-3 Lower Main Frame Installation

Secure the lower main frame P#(B0821) to the left rear frame of the mower using (4) 3/8"-16 x 1" carriage bolts P#(K1182) and (4) 3/8"-16 nylon flange locknuts P#(K2038). Leave the hardware loose. Secure the lower main frame to the PTO mount plate assembly using (2) 3/8"-16 x 1" carriage bolts P#(K1182) and (2) 3/8"-16 nylon flange locknuts P#(K2038). Align lower main frame and PTO mount assembly to be parallel and level to the mower's chassis, then tighten all hardware from Sections 2-2 and 2-3 at this time. Refer to Figure 2-3.

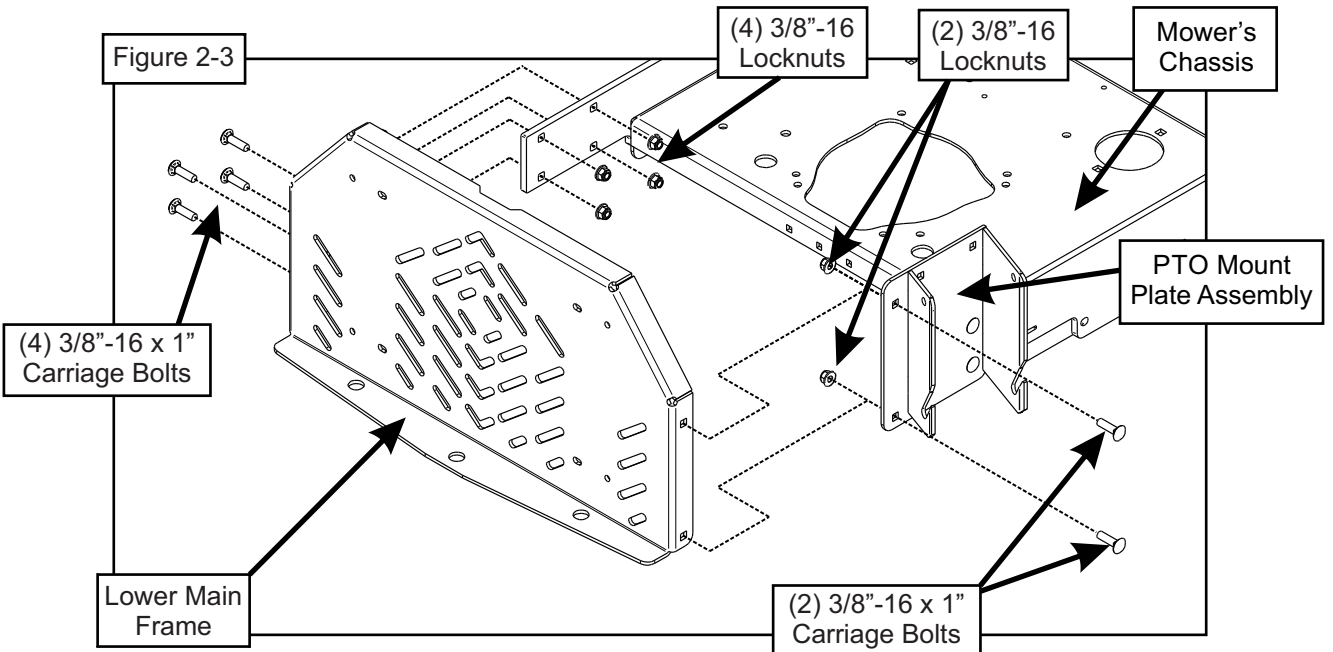

2-4 PTO Assembly Installation

Insert the PTO assembly P#(A1821) into the slots on the PTO mount plate assembly. Secure the PTO assembly with (1) mount pin P#(B0274) and (1) hair pin clip P#(K0086).

Remove the belt guard P#(B0679) and hardware in preparation for the belt installation. Refer to Figure 2-4a.

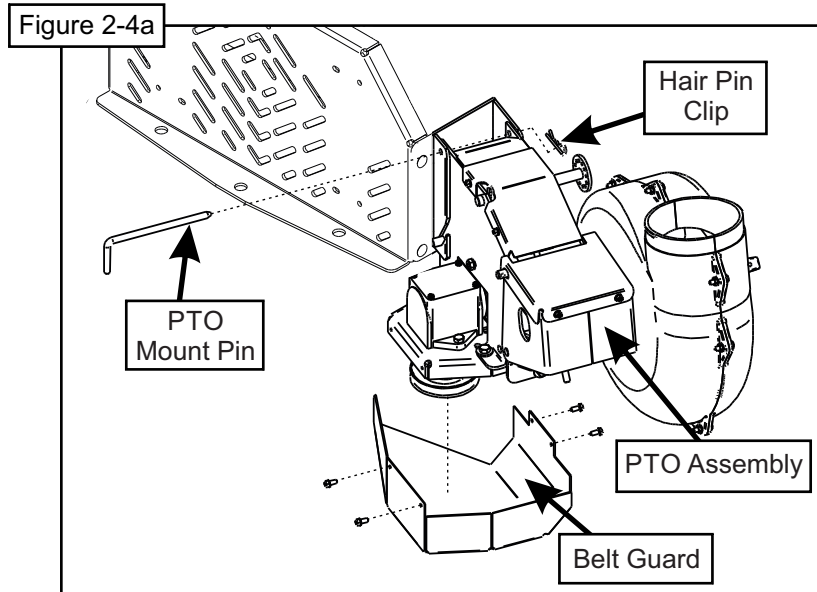

Attach the PTO handle P#(A1142) to the PTO assembly using (3) 1/4"-20 x 3/4" HHCS P#(K1222) and (3) 1/4"-20 nylon flange locknuts P#(K2014). Attach the handle grip P#(J0522) to the PTO handle. Refer to Figure 2-4b.

NOTE: The PTO Handle can be adjusted after performing Step 2-6 to achieve proper belt adjustment. To adjust the handle, remove (3) 1/4"-20 x 3/4" HHCS P#(K1222) and (3) 1/4"-20 nylon flange locknuts P#(K2014), rotate handle until positioned in the desired location (while aligning holes) and reattach. The bolts should be kept approximately 120 degrees apart to ensure proper fastening.

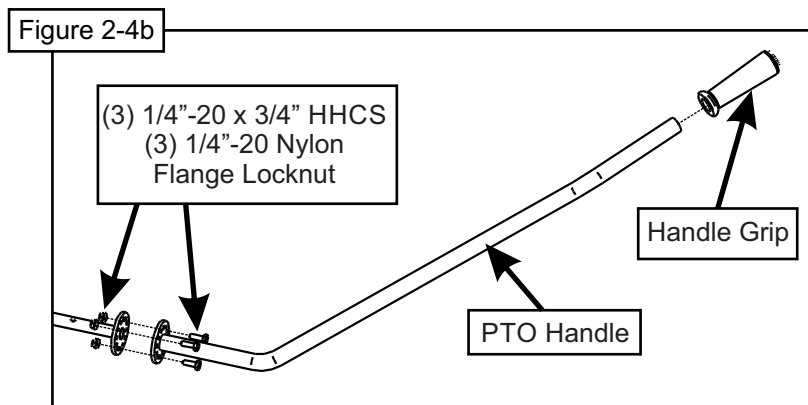

2-5 Drive Belt Installation and Adjustment

Loosen the (4) bolts P#(K1191), (2) on each side, that secure the gear box assembly to the PTO assembly P#(A1803) (Figure 2-5a and 2-5b).

Figure 2-5a

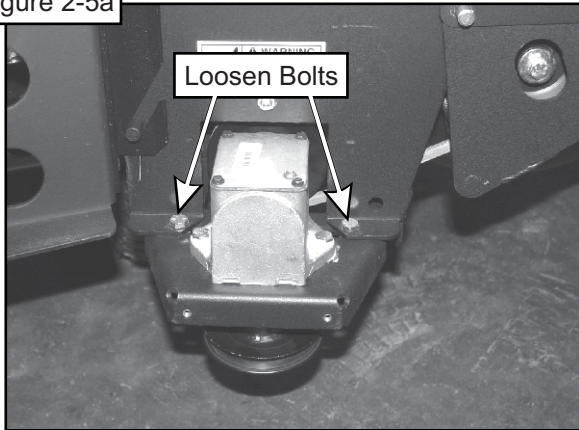
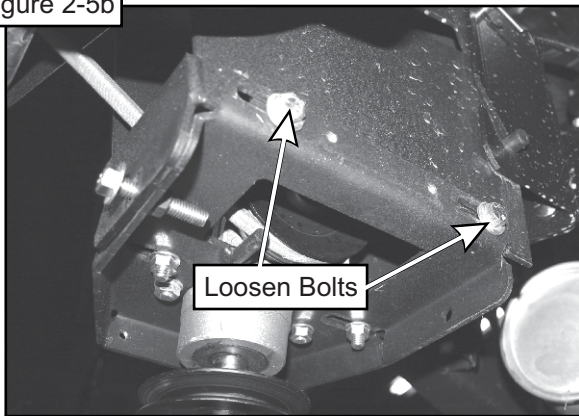
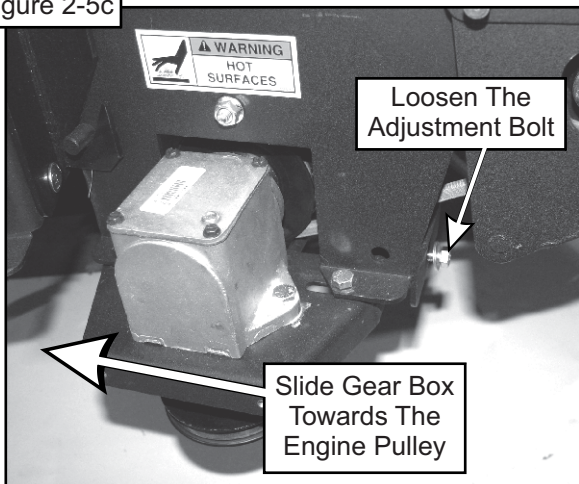

Figure 2-5b



Loosen the adjustment bolt P#(K0348) until the gear box assembly is at its far left adjustment (the gear box is moved toward the mower's engine pulley). Refer to Figure 2-5c.

Figure 2-5c



Connect the drive belt A59K P#(M0254) from the engine pulley to the lower gear box pulley (Figure 2-5d).

Figure 2-5d

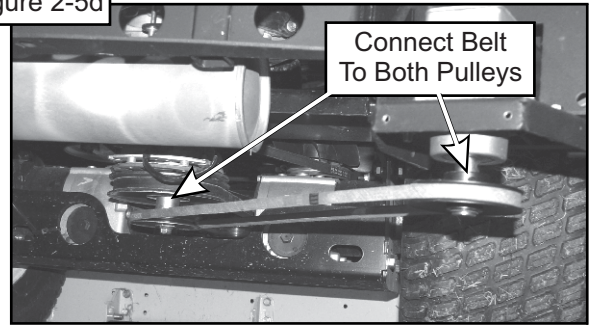

To tension the drive belt, turn the adjustment bolt clockwise (Figure 2-5e) until there is 1" of deflection, with 10-11 lbs. of pressure, at the center of the belt between the engine pulley and the gear box pulley.

Figure 2-5e

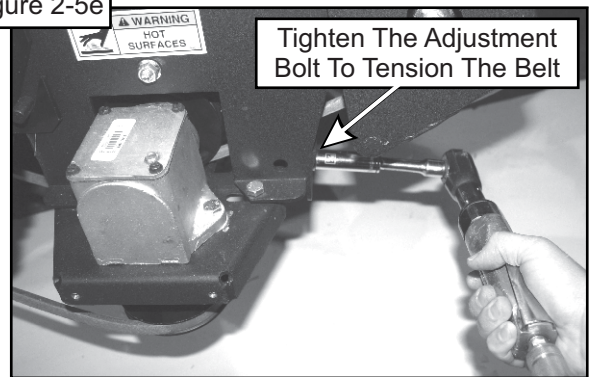

Once the correct tension of the belt is achieved, tighten the (4) bolts that secure the gear box assembly. Refer to Figures 2-5f and 2-5g. Replace the belt guard and hardware that was removed in Section 2-4.

Figure 2-5f

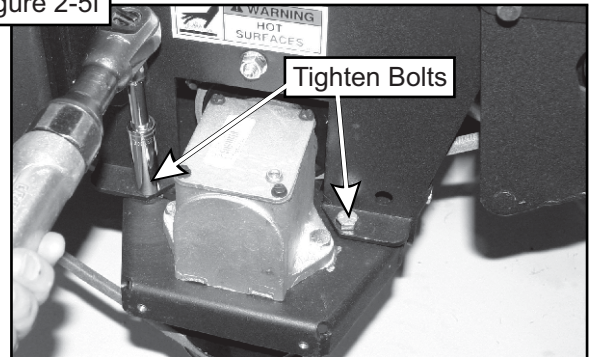
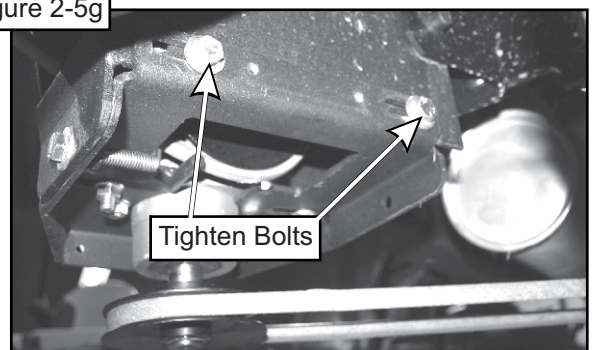

Figure 2-5g



2-6 Cam Assembly Adjustment

The cam assembly P#(A0422), which controls the A30K blower belt P#(M0250) tension, comes from the factory pre-adjusted. If the belt is too tight or becomes too loose, remove the hair pin clip P#(K0099) from the belt tension rod P#(K0326) and pull the "L" end of the rod out of its hole in the cam assembly. The tension rod may then be screwed out to tighten the belt or screwed in to loosen the belt. Replace the "L" end into the top hole in the cam and replace the hair pin clip. Adjust the cam stop bolt P#(K1159) to allow the cam to rotate slightly over center when the blower is disengaged (Figure 2-6).

Figure 2-6

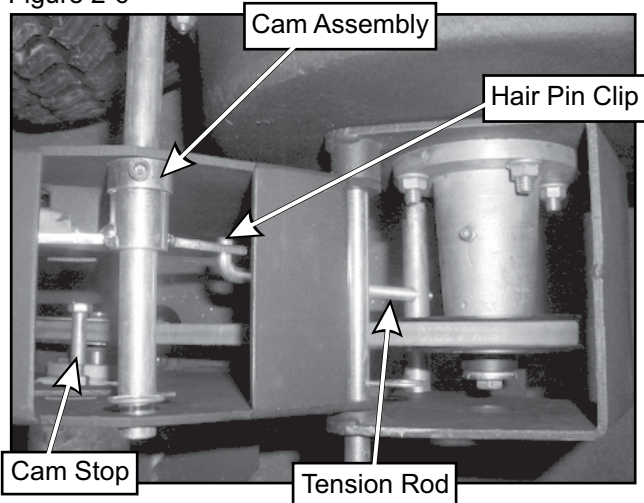

2-7 Blower Cone Installation

Thread (1) 5/16"-18 jam nut P#(K0120) onto each end of (2) 5/16"-18 x 2-1/2" HHCS P#(K0125) as shown in Figure 2-7a.

Figure 2-7a

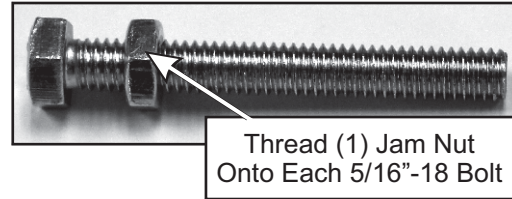

Now partially thread (1) bolt into each of the two threaded bosses located on the blower housing. Place blower cone so the two tabs line up with the bolts and tighten completely as shown in Figure 2-7b.

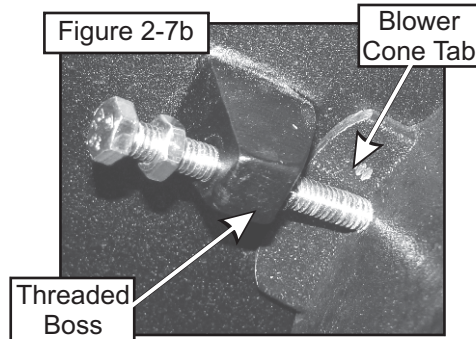

Once the (2) bolts are tight, tighten the jam nuts against the threaded boss as shown in Figure 2-7c.

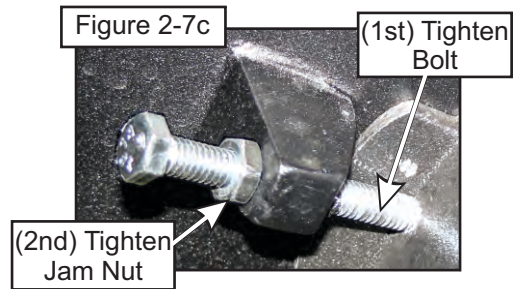

Refer to Figure 2-7d for proper blower cone installation reference.

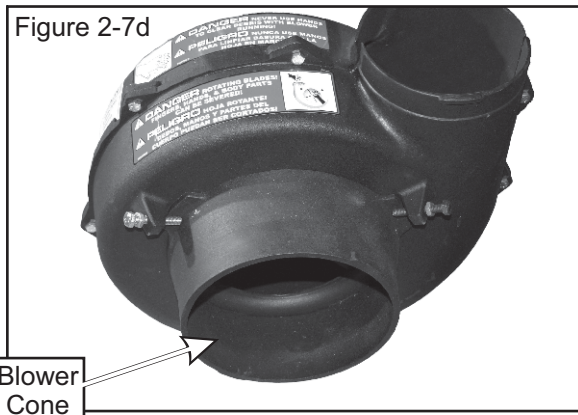

2-8 Safety Interlock Harness

Installation

To obtain access to the mower's safety interlock switch, lift the operator's seat on the mower as shown in Figure 2-8a. Refer to your Cub Cadet operator's manual for reference.

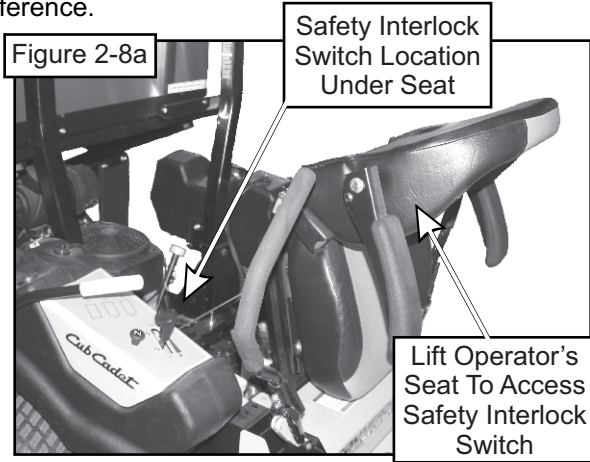

Locate the collection system's safety interlock harness P#(P0208) connected to the PTO assembly P#(A1821) and shown in Figure 2-8b. Cut the zip-ties retaining the safety interlock harness to the PTO assembly, to allow routing the harness to its proper location.

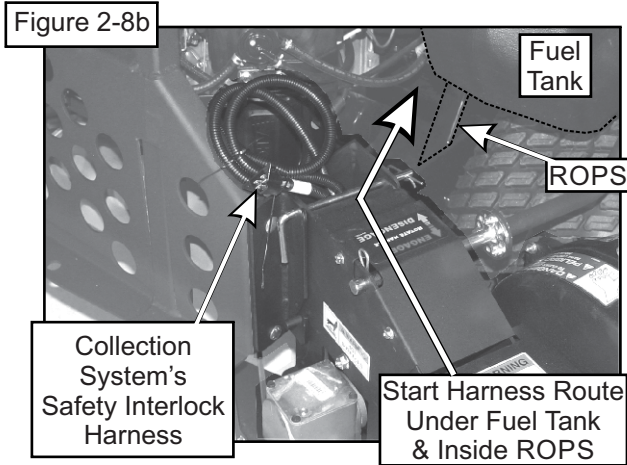

Begin routing the safety interlock harness from the PTO assembly, underneath the right fuel tank and inside the ROPS tube. Secure the harness where indicated in Figure 2-8c, using the included zip ties P#(J0245). Ideally, the harness should be clear of any moving parts or mechanisms. The harness should not come in contact or be in close proximity with any heat sources. Use as many zip ties as needed to ensure the harness is tightly secured to the mower, and free from any pinch points or potential areas that may cause damage to the harness.

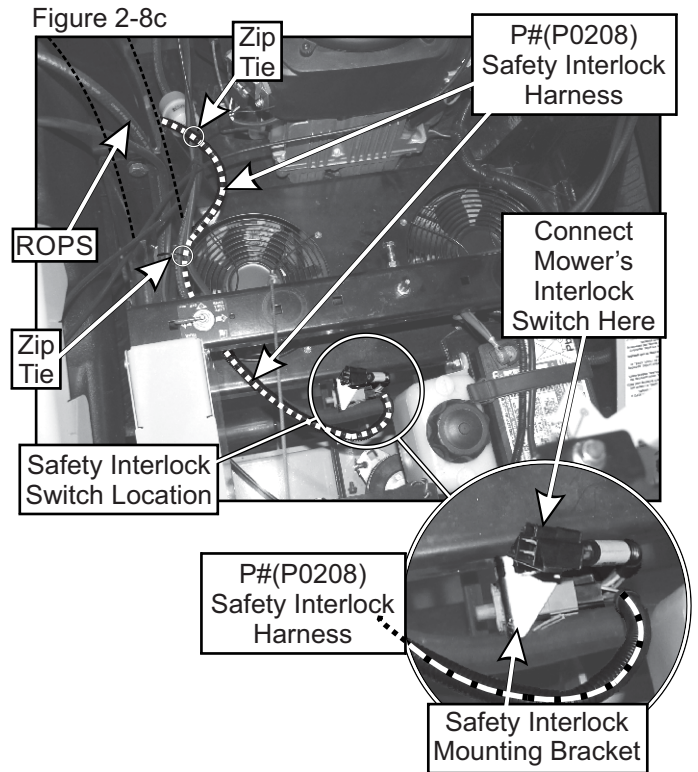

Disconnect the mower's safety interlock switch (See mower's Owner's Manual for location). Plug the male end of the collection system's wiring harness into the port where the mower's safety interlock switch was removed. Then, plug the mower's safety interlock switch into the female end of the collection system's wiring harness. Refer to Figure 2-8c.

Use Figure 2-8c and 2-8d for clarification on the location of the mower's existing safety interlock switch and where the collection system's safety interlock harness should be connected. A wiring schematic for the P#(P0208) safety interlock harness is located on page 24 for reference.

Figure 2-8d

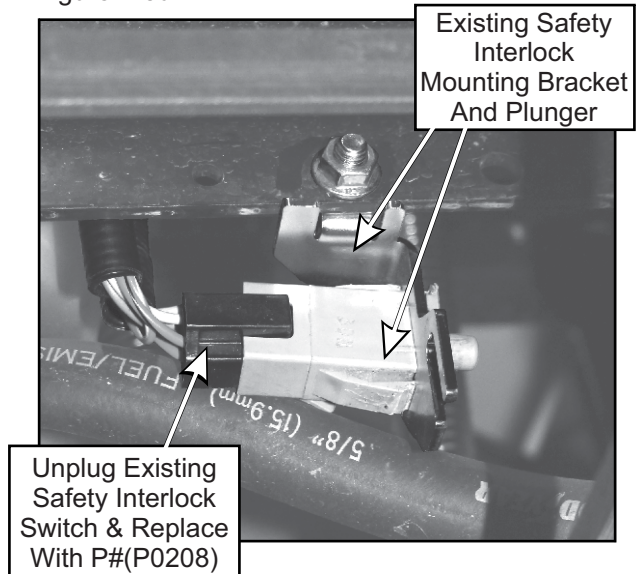

2-9 Lower Mount Tube Installation

Secure the (2) lower mount tubes P#(B0640) to the lower main frame using (2) 5/16"-18 u-bolts P#(K1098) and (4) 5/16"-18 nylon flange locknuts P#(K2516) PER TUBE. Refer to Figure 2-10.

2-10 Upper Frame Assembly Installation

Position the upper frame assembly P#(A1058) above the lower mount tubes as shown in Figure 2-10. Slide the upper frame assembly down onto the lower mount tubes and secure using (2) clevis pins P#(K0133) and (2) hair pin clips P#(K0088).

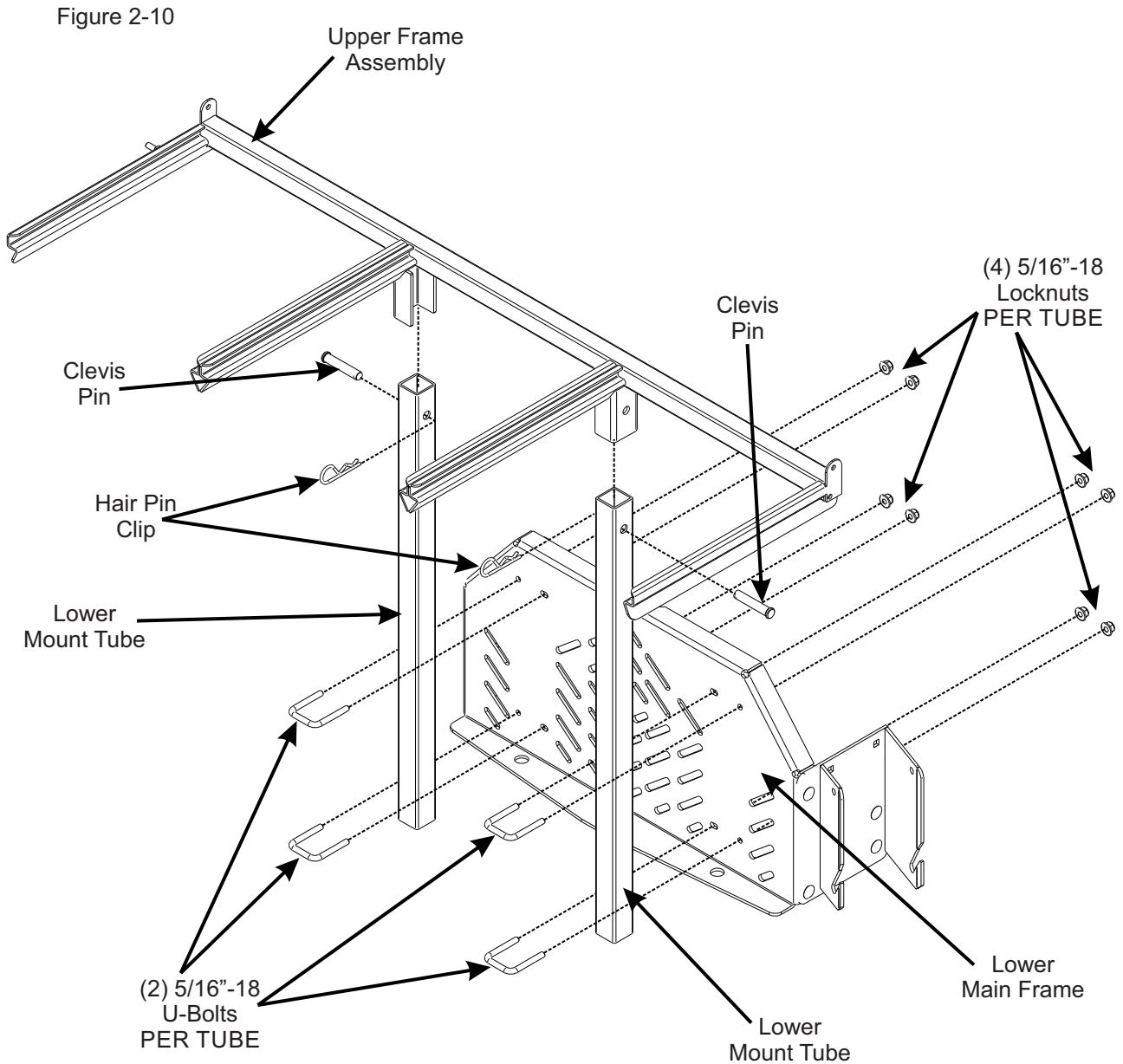

2-11 Top Assembly To Upper Frame

Assembly Installation

Position the top assembly P#(A1139) above the upper frame assembly as shown in Figure 2-11. Fasten the top assembly to the upper frame assembly using (2) 5/16"-18 x 2-1/2" HHCS P#(K0125) and (2) 5/16"-18 nylon flange locknuts P#(K2516). Leave the locknuts slightly loose, to allow the top assembly to open and close easily. Refer to Figure 2-11 for hardware location.

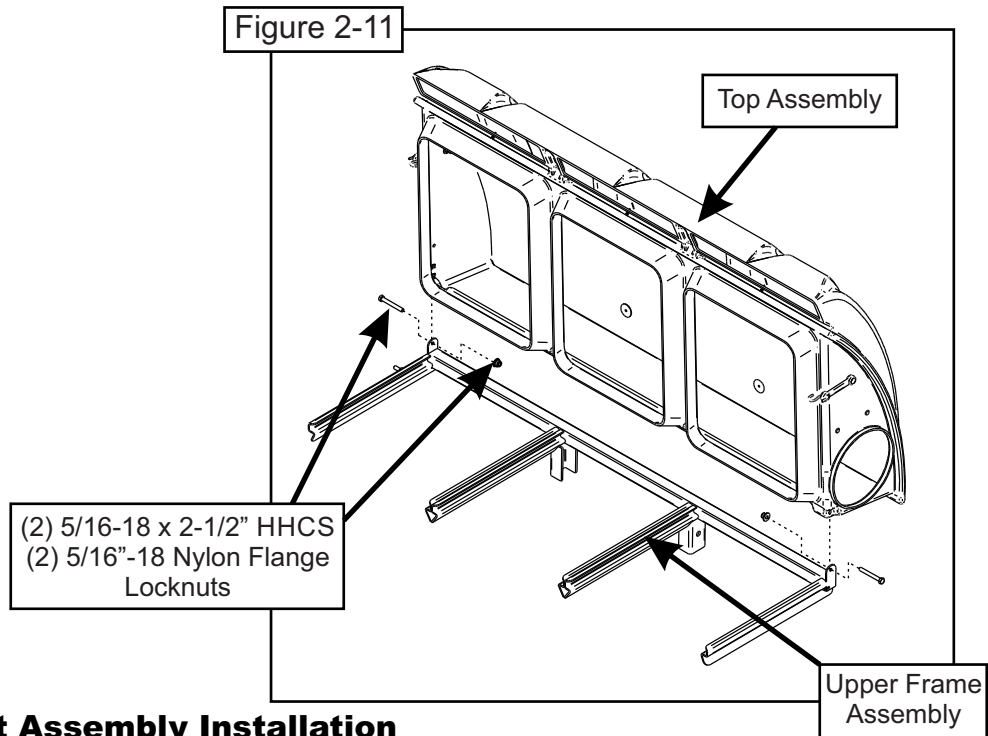

2-12 Hinge Kit Assembly Installation

Assemble the hinge kit as shown in Figure 2-12, using (2) 5/16"-18 x 1" HHCS P#(K1154), (3) 5/16"-18 nylon flange locknuts P#(K2516), (5) 1/4" flat washers P#(K0037) and (2) swing arm brackets P#(ZT-0004). Place (1) vinyl cap P#(J0289) on the end of the hex bolts as shown in Figure 2-12. Leave the nuts loose enough to allow fluid movement of the top when opening and closing. When opened, the top should rest on the middle joint of the hinge allowing it to remain up.

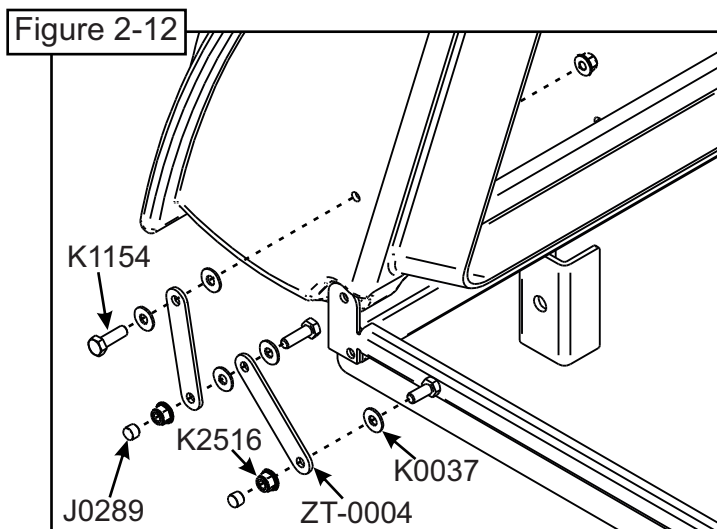

2-13 Boot To Mower Deck Installation

NOTE: The boot kit assembly is designed to fit the 48", 54" and 60" decks. To ensure a snug fit between the boot and the mower deck, follow the instructions in this step thoroughly, and remove and tighten all hardware in the sequence specified.

Lift the grass deflector on the mower deck. Secure the deck plate assembly P#(A1960) to the discharge chute of the mower deck using (2) 5/16"-18 x 1" carriage bolts P#(K1144) and (2) 5/16"-18 nylon flange locknuts P#(K2516). Refer to Figure 2-13a.

Secure the boot plate assembly P#(A1961) to the aluminum boot P#(E0026) using (2) 3/8"-16 x 1" carriage bolts P#(K1182) and (2) 3/8"-16 nylon flange locknuts P#(K2038). Insert the carriage bolts from the inside of the boot so the threads are on the outside of the boot (Figure 2-13a). This will prevent grass clippings from collecting on the bolt threads.

Align the mount holes in the boot plate assembly with the mounting holes in the deck plate assembly and insert (1) boot rod P#(B0288) into the mounting holes. Secure the boot rod with (1) hair pin clip P#(K0099). Refer to Figure 2-13b.

Figure 2-13a

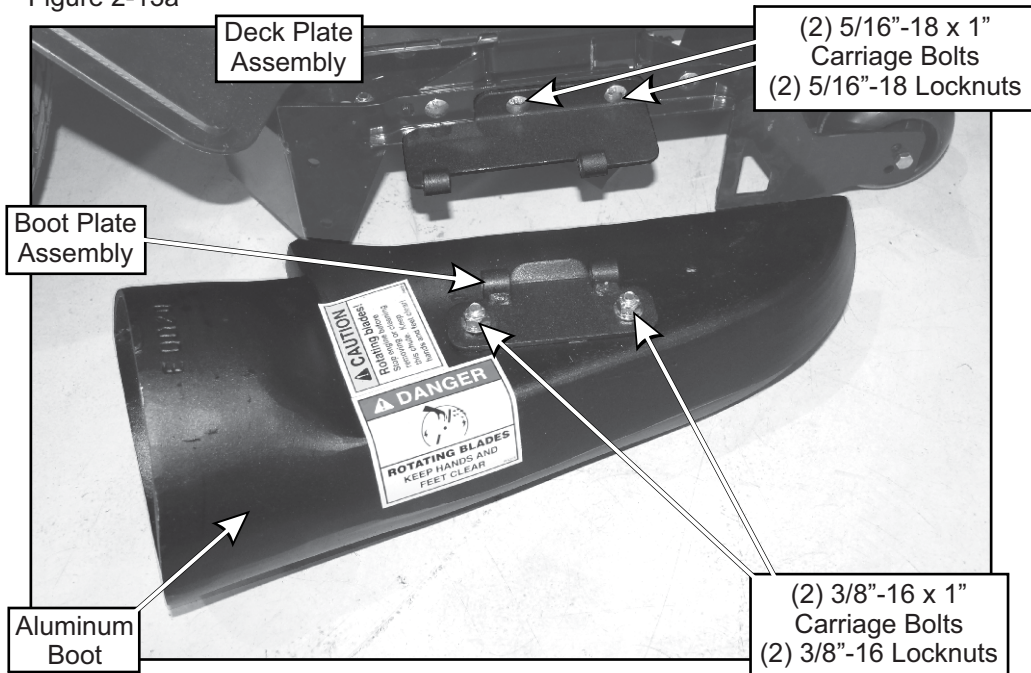
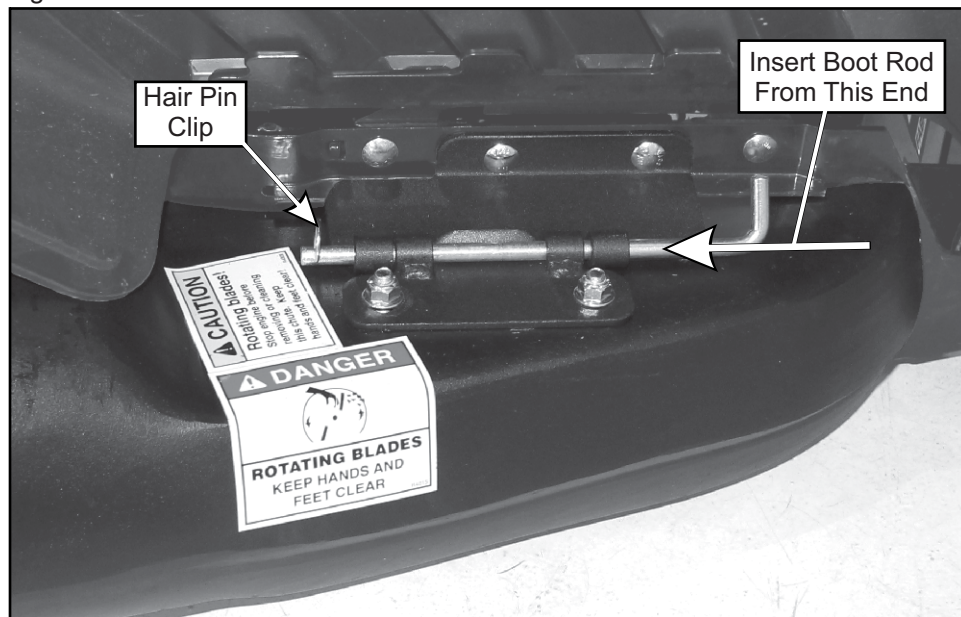

Figure 2-13b



2-14 Length Of Hose Adjustment

The hoses in steps 2-15 and 2-16 must be cut to fit your machine. Follow steps 2-15 and 2-16. Do not cut the hoses until you have tried to fit them on your machine. Remember that the hoses have to be long enough to adjust for the blower assembly's movement as well as allow for enough clamping surface between the inlet, blower assembly, and the deck boot.

2-15 Upper Hose Installation

Fasten the inlet to the plastic top by sliding the inlet from the inside of the top to the outside and lock into place. Slide a 6" hose clamp P#(J0060) onto both ends of the 6" upper hose (Figure 2-17). Then slide one end of the 6" hose onto the inlet. Make sure there is about a two-inch overlap between the hose end and the container inlet. Proceed to slide the opposite end of the 6" hose onto the outlet of the blower assembly. See (Figure 2-17) for details. Make sure both ends of the hose are clearly attached to the inlet and the blower assembly inlet. Tighten the hose clamps.

2-16 Lower Hose To Blower Cone Installation

Slide a 8" hose clamp P#(J0080) over both ends of the lower hose. Then proceed to slide the lower hose onto the blower cone. Tighten the hose clamp. The assembly should look like Figure 2-17.

2-17 Lower Hose To Boot Installation

Take the unattached end of the lower hose and slide it over the circular end of the boot. Use the lower hose clamp to secure the hose to the boot (Figure 2-17). Tip: Before securing clamp rotate hose counter-clockwise (away from yourself) approximately 1" to aid in retaining boot to mower deck.

Figure 2-17

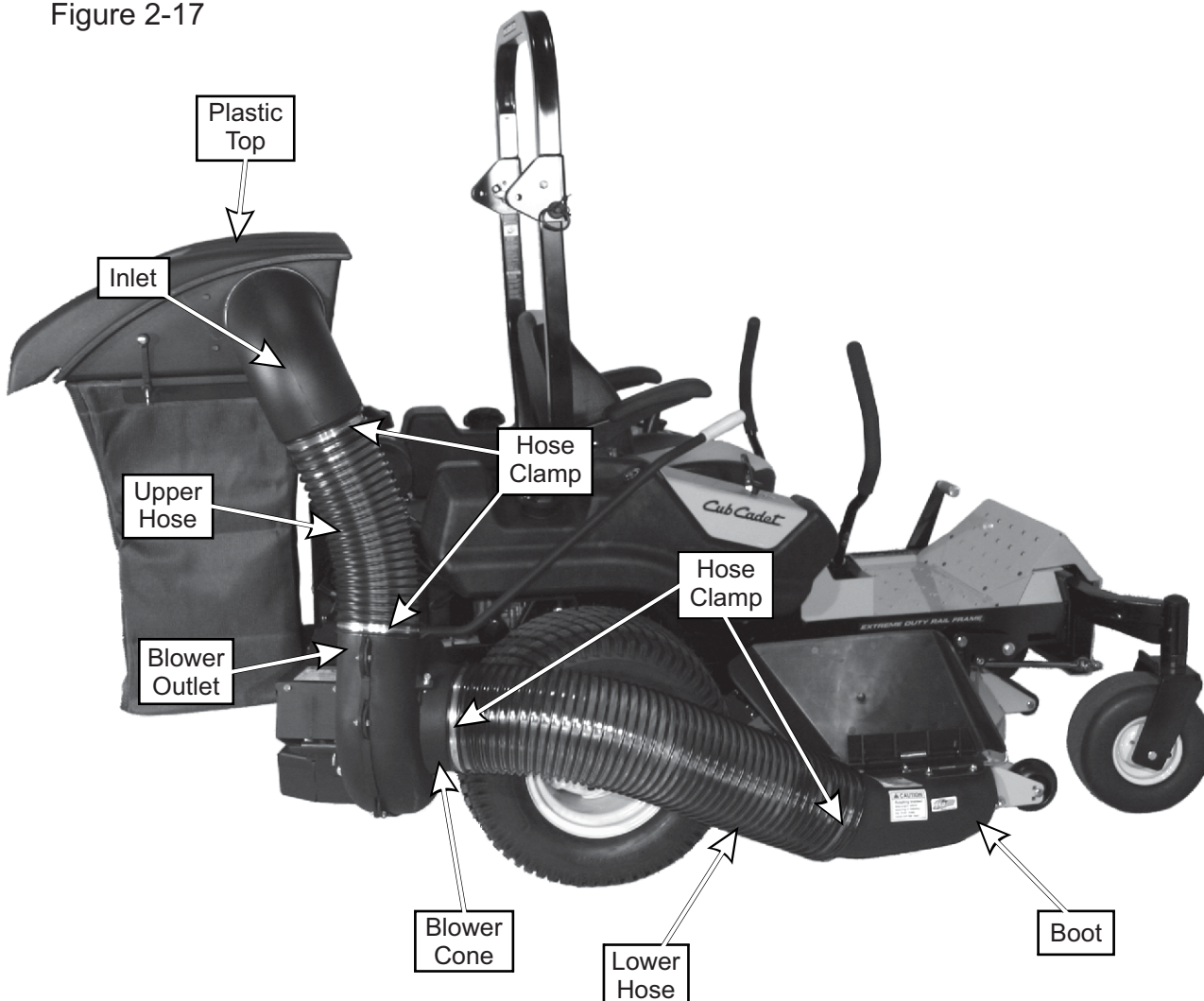

2-18 Impeller Blade Removal/Replacement

To gain impeller blade (#1) access, first remove the blower cone (#2) from the blower housing, located on the PTO assembly P#(A1821), by removing two blower cone bolts and nuts (#3). Next, remove the blower housing front (#4) by removing seven bolts and nuts (#5) around the outer housing edge. Refer to Figure 2-18.

To Remove: First, remove one 3/8"-16 x 1-1/2" HHCS P#(K1211) (#6), one taper-lock bushing washer P#(K0278) (#7) and one spacer bushing P#(S3242) (#8) from the taper-lock bushing (#9). See Figure 2-18. Next, remove two 1/4"-20 x 1" HHCS (#10) and place them into the threaded holes (#11) of the taper-lock bushing P#(S4302). Last, gradually thread each bolt evenly into the taper-lock bushing, forcing the blade to break-away from the taper-lock bushing.

Tips on removing impeller blade;

- 1 - Try carefully hitting the base of the impeller blade (#1), between each vein (#12), with a rubber mallet to loosen the taper-lock bushing hold.
- 2 - Spray break-free lubricant into the surrounding areas of the taper-lock bushing (#9) and repeat Tip 1.

To Replace: First, place the impeller blade (#1) over the drive shaft (#13). Next, slide the taper-lock bushing (#9) on to the drive shaft and into the impeller blade, aligning the **non-threaded** holes (#14) of the taper-lock bushing to the threaded holes of the impeller blade. Then, fasten by using two 1/4"-20 x 1" HHCS (#10), one spacer bushing (#8) one taper lock bushing washer (#7), and one 3/8"-16 x 1-1/2" HHCS (#6). Torque all bolts to the specifications located in the chart towards the back of this manual. Last, rotate the impeller blade to ensure that the blade is clear of contact on all sides of the blower housing.

Figure 2-18

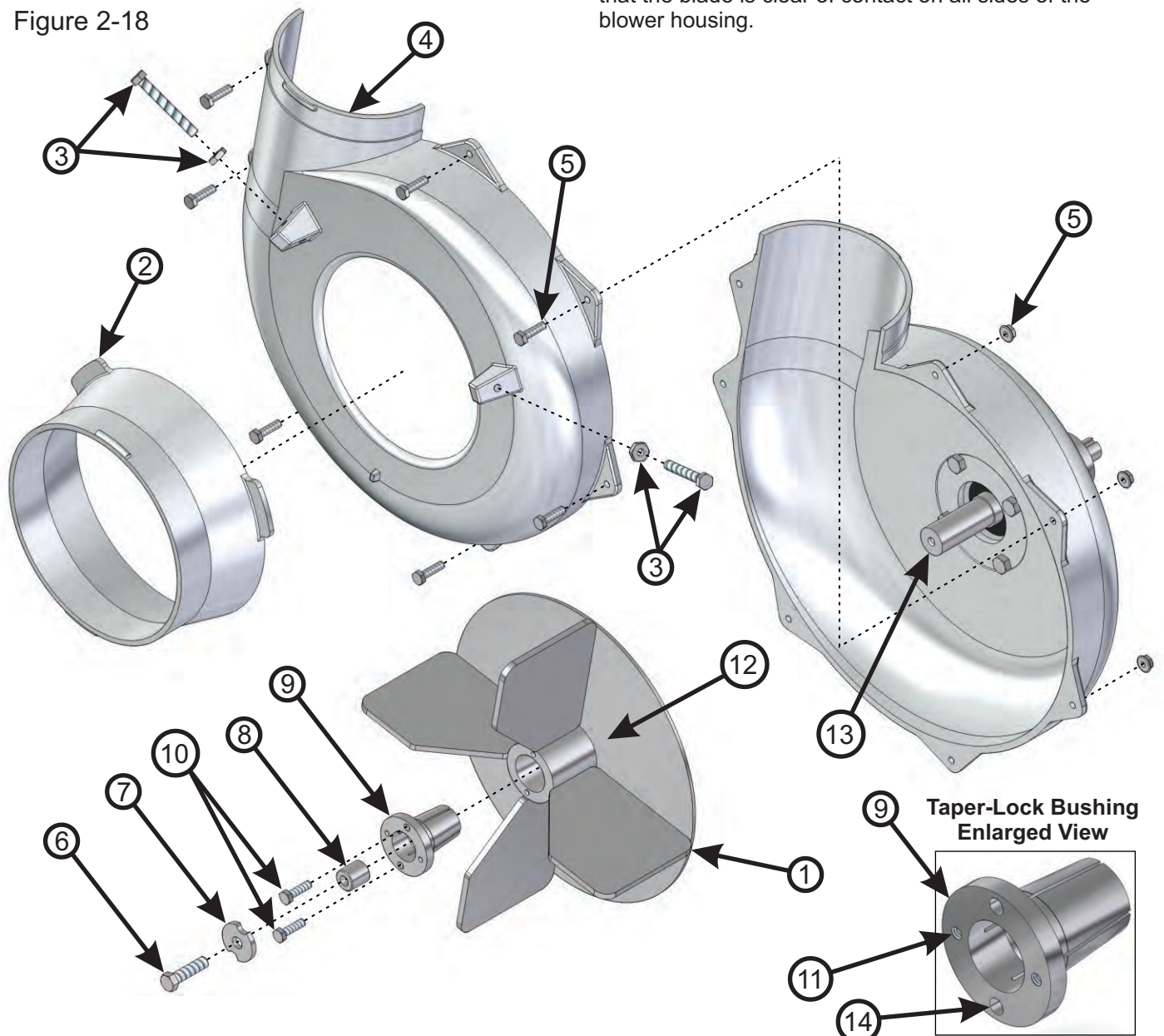

2-19 Installation/Removal Of Collection Bags

IMPORTANT!

To prevent bag wear, install (2) red plastic end caps P#(J0274), as shown in Figure 2-19a, on each bag ring before installing bags.

Figure 2-19a

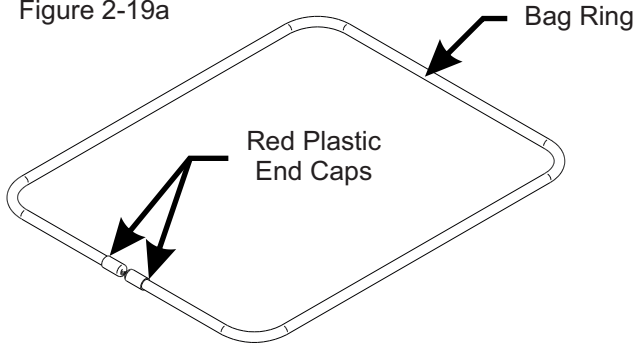

To install the bag onto the bag ring, place the seam openings of the bag onto the bag ring openings and turn the bag one full turn (360°) so the plastic end caps are located opposite to the opening in the bag (Figure 2-19b). Do this for each of three bags.

Figure 2-19b

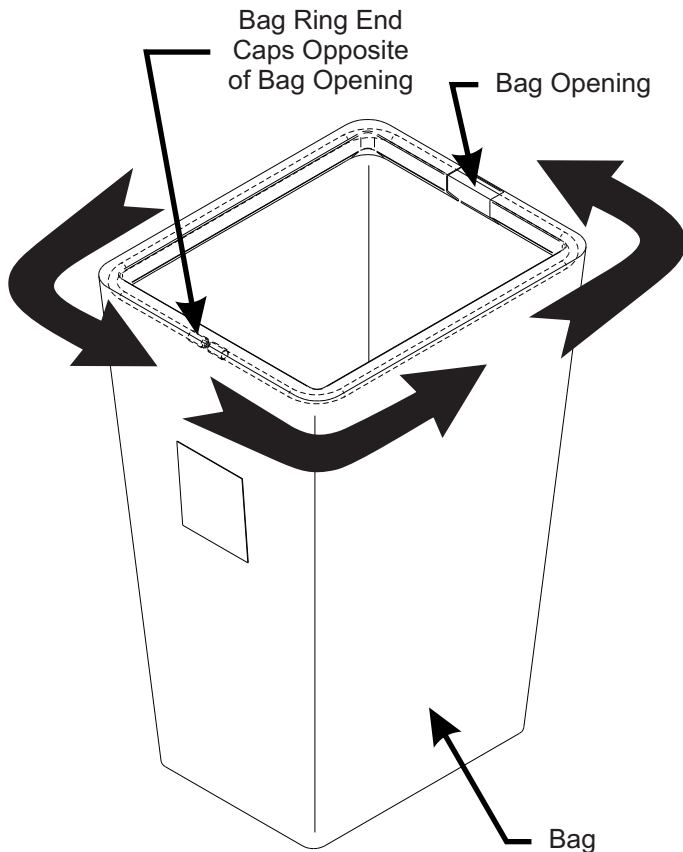

Install the completed assemblies onto the support frame and close the plastic top. Fasten both draw-latches to hold the plastic top closed (Figure 2-19c).

Figure 2-19c

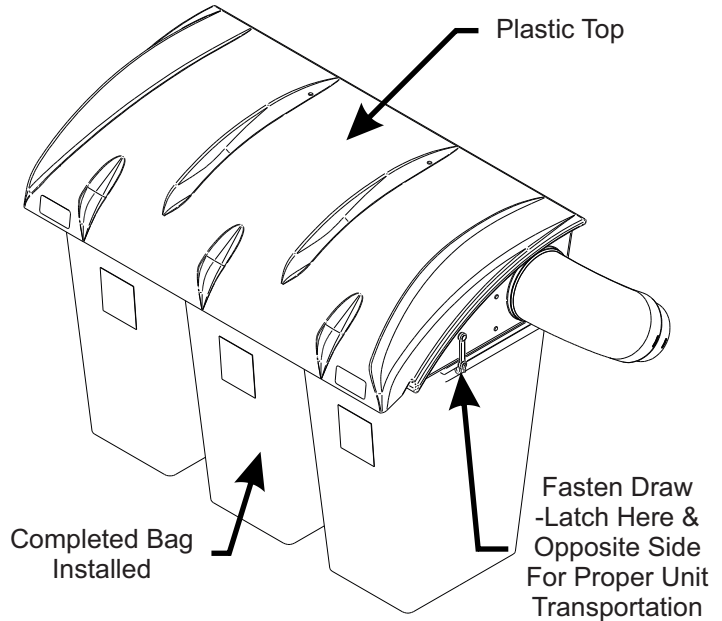

To empty the bag, first unlatch and lift top, next remove the bag and bag ring by sliding rearward, then grasp the loop on the bottom of the bag, and last turn it upside down to empty the collected debris (Figure 2-19d). Repeat for the other bags, line with plastic bags if desired, close the plastic top and reattach the draw latches.

Figure 2-19d

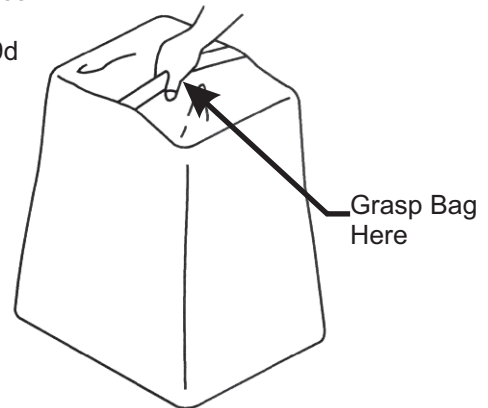

Plastic lawn and leaf bags, 33 gallon size, may be used inside the cloth bags. Be sure to leave enough plastic bag hanging over the frame so the plastic bags can be twist tied before emptying (Figure 2-19e).

Figure 2-19e

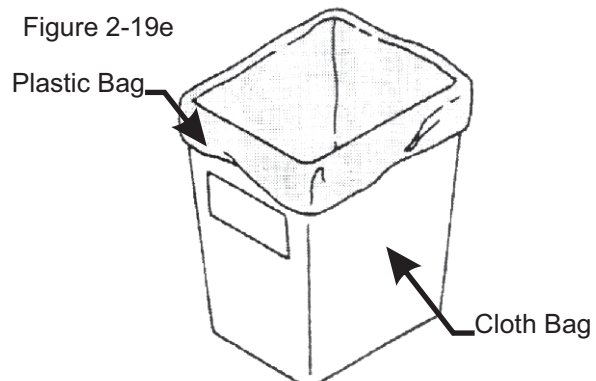

2-20 Weight Kit Installation

2012-2014 Tank LZ Models - Installing a weight kit is mandatory for safe operation of the collection system. SZ models **do not** require a weight kit.

Completely thread (2) 3/8"-16 flange nuts P#(K1215) onto (1) 3/8"-16 U-bolt P#(K0407). Repeat process again to create two sets. Secure each U-Bolt, w/ attached flange nuts, to the weight bracket P#(B0703) using (2) 3/8"-16 nylon flange locknuts P#(K2038) as shown in Figure 2-20a.

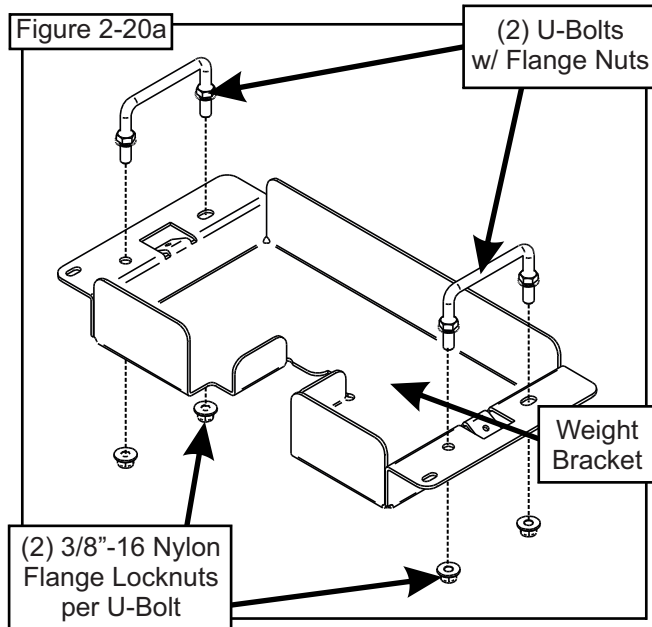

Remove the mower's pulley access cover shown in Figure 2-20b.

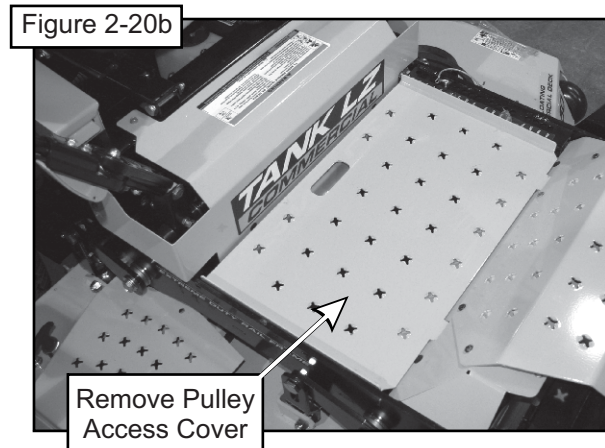

Insert the weight bracket assembly into the recess as shown in Figure 2-21c. Align the weight bracket's mounting holes to the mower's frame and secure using (2) 1/4"-20 x 3/4" HHCS P#(K1222) and (2) 1/4"-20 nylon flange locknuts P#(K2014). Insert the bolts from the bottom of the weight bracket so that the nuts fasten to the top of the bracket as shown in to Figure 2-20c.

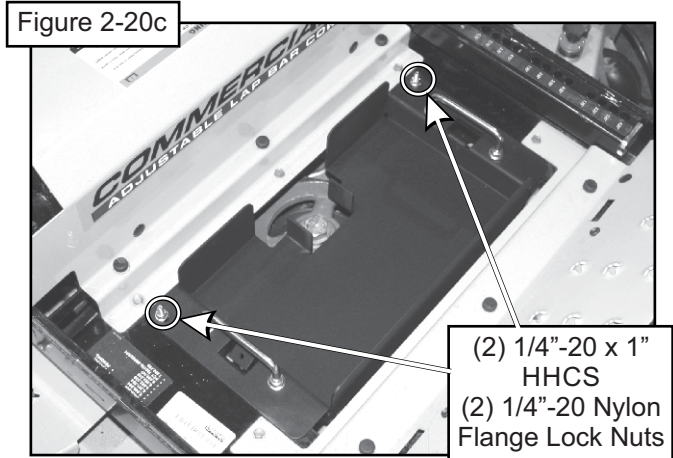

One at a time, add (1) large weight bar P#(B0704) to the weight bracket, then (2) small weight bars P#(B0741). Refer to Figure 2-20d.

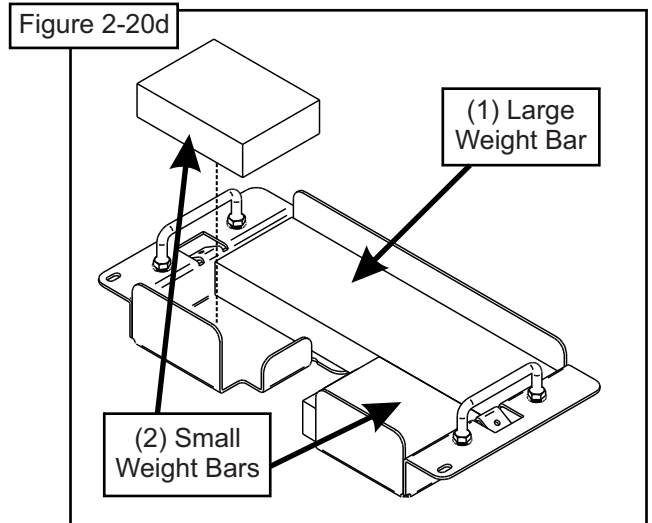

Add the remaining (2) large weight bars P#(B0704) to the weight bracket. Secure the weights to the weight bracket with (1) weight strap P#(B0719) and (2) 1/4"-20 self-tapping screws P#(K0353). Refer to Figure 2-20e. Replace mower's pulley access cover when completed.

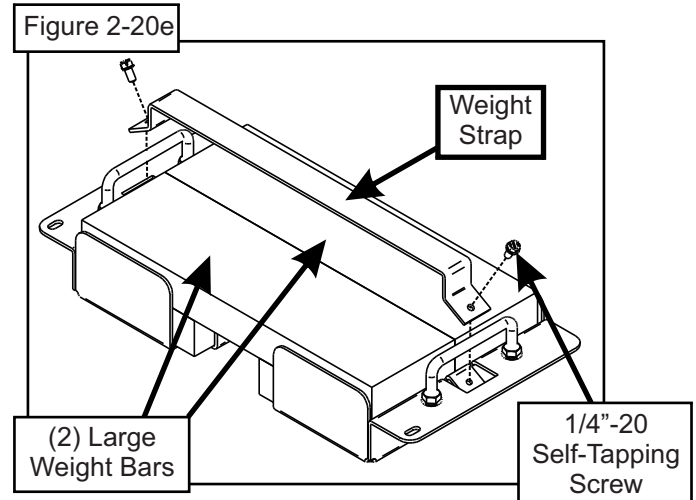

Exploded Parts View

A1139 Top Assembly

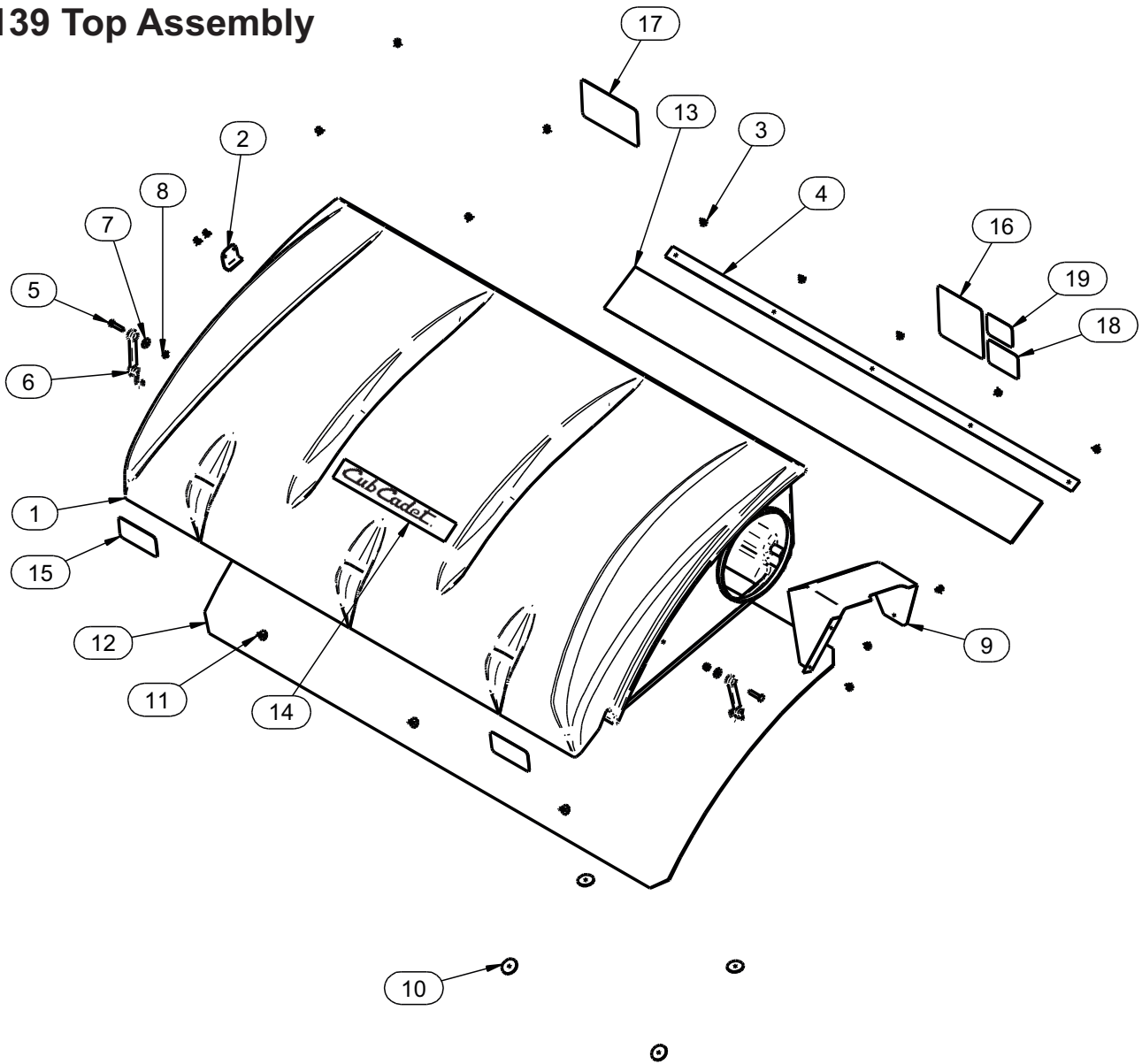

Item #	Doc #	Title	Qty
1	V0022	PRO 3 BAGGER TOP	1
2	B0676	Hinge Stop Pl.	1
3	K0114	BLACK PLASTIC RIVET	14
4	C0069	DUST GUARD BRACE	1
5	K1030	1/4"-20 x 1-1/4" CARRIAGE BOLT	2
6	J4009	SHORT RUBBER STRAP W/ S HOOK	2
7	K0037	1/4" FLAT WASHER .75 OD x .314 ID x .060 T	2
8	K1128	1/4"-20 NYLOC NUT	2
9	C0026	GRASS DEFLECTOR	1
10	K0062	3/16" x 1-1/2" FENDER WASHER, Z	4
11	K1265	BLACK PANEL RETAINER	3
12	V1120	SCREEN	1
13	V1118	DUST GUARD	1
14	R0006	CUB CADET LOGO	1
15	R1057	2" x 4" Red Reflector Label	2
16	R1069	Warning - Turn Off Blower Label	1
17	R1065	Made In USA Label	1
18	R1054	Important Check Hoses	1
19	R1051	Warning - Use Hearing Protection	1

Exploded Parts View

A1821 PTO Assembly

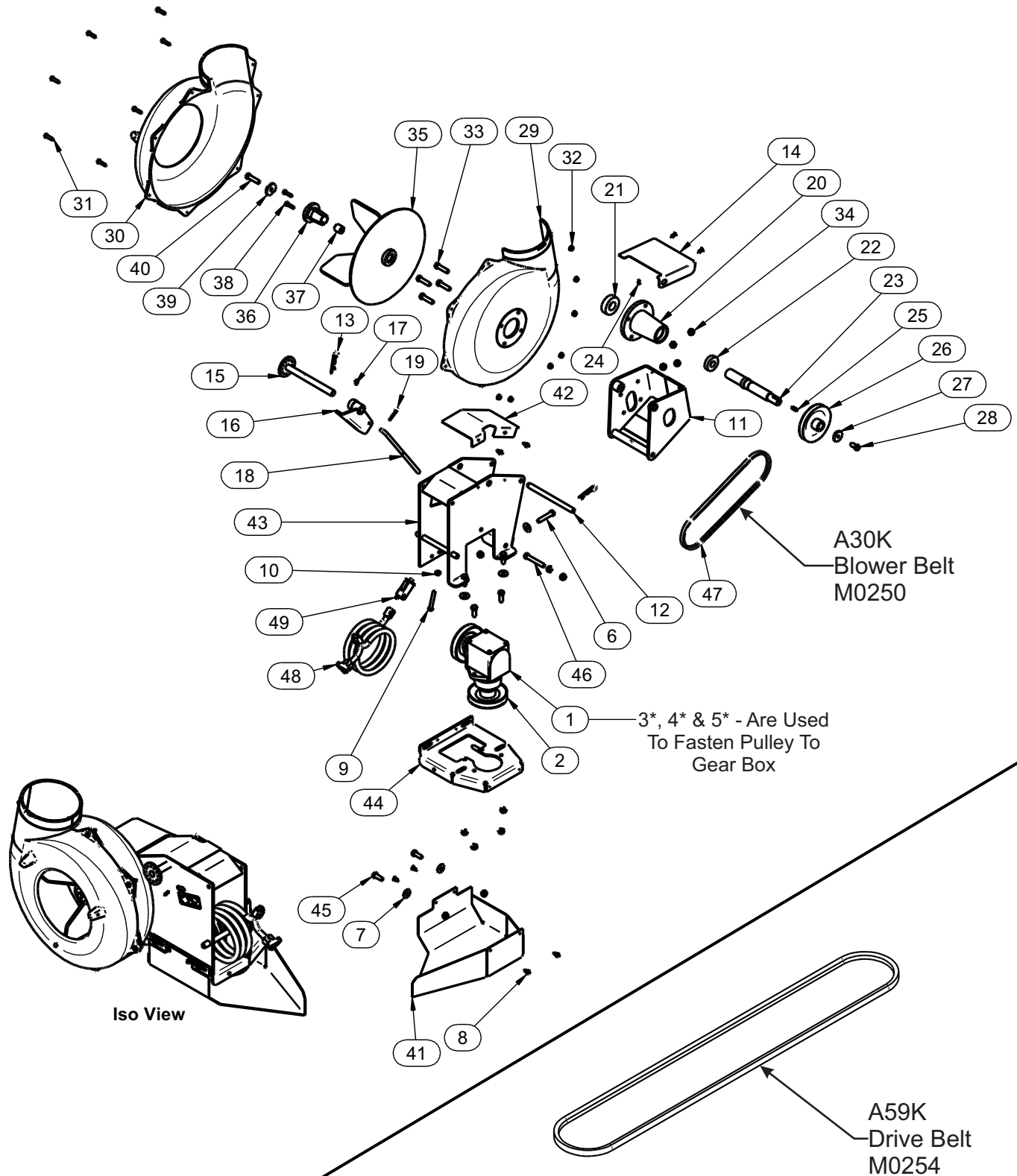

PTO Parts List

A1821 PTO Assembly

Item #	Doc #	Title	Qty
1	A0431	GEAR BOX	1
2	A0498	PULLEY ASSY. FOR GEAR BOX	2
3*	K0360	7/8" SNAP RING	2
4*	J0272	#9 WOODRUFF KEY	2
5*	K0035	5/16-18 SET SCREW	2
6	K0348	3/8"-16 x 2" ALL THREAD HHCS	1
7	K0047	3/8" FLAT WASHER 1.00 OD x .446 ID x .075 T	5
8	K0353	1/4"-20 x 1/2" HHSTS	8
9	K1159	5/16"-18 x 2" ALL THREAD HHCS	1
10	K1178	5/16"-18 FLANGE NUT	1
11	A0144	BLOWER MOUNT BRACKET ASSEMBLY	1
12	B1755	BLOWER PIVOT ROD	1
13	k0086	.125 OD x 2.50 HAIR PIN CLIP	2
14	b0121	BLOWER BELT GUARD	1
15	A0604	PTO HANDLE MOUNT ASSY	1
16	A0422	CAM BRACKET ASSEMBLY	1
17	K0356	3/8"-16 TAPERED SET SCREW	1
18	k0326	BELT TENSION ROD 3/8"-16	1
19	K0130	.091 OD x 1.625 L HAIR PIN CLIP	1
20	e0121	PTO SHAFT HOUSING	1
21	n0147	BEARING 2.0472 OD, 0.9843 ID, 0.5906 W (6205RS PEER)	1
22	n0148	BEARING 1.625 OD, 0.75 ID, 0.4375 W (9R12 PEER)	1
23	b1758	PTO SHAFT	1
24	J0801	1/4"-28 ZIRC FITTING	1
25	J0254	3/16" SQ. x 3/4" LONG KEYWAY	1
26	M0228	BLOWER PULLEY	1
27	K1446	1.187 OD x .380 ID x .187 WASHER	1
28	K1190	3/8"-16 x 3/4" HHCS	1
29	E4004B	BLOWER HSG. BACK	1
30	E4004F	BLOWER HSG. FRONT	1
31	K1125	1/4"-20 X 1" HHCS	7
32	K1126	1/4"-20 FLANGE NUT	7
33	K1193	3/8"-16 x 1-1/2" HHCS	4
34	K1215	3/8"-16 FLANGE NUT	12
35	A0645	SMALL 4-BLADE IMPELLER	1
36	S4302	TAPER-LOCK BUSHING	1
37	S3242	PLATED BUSHING	1
38	K1225	1/4"-20 X 1" HHCS GRADE 8	2
39	K0278	TAPER-LOCK BUSHING WASHER	1
40	K1211	3/8"-16 x 1-1/2" HHCS GRADE 8	1
41	B0679	GEAR BOX PULLEY GUARD	1
42	B0270	PTO ARM GUARD	1
43	A1804	PTO ARM ASSY.	1
44	A0624	BASE PLATE ASSY.	1
45	K1191	3/8"-16 x 1" HHCS	6
46	K1197	3/8"-16 X 2 1/2" HHCS	1
47	M0250	A30K KEVLAR BELT	1
48	P0208	SAFETY INTERLOCK HARNESS	1
49	P0209	PLUNGER SWITCH	1



Unit Model #: 59A3004150 (21131508)

Mower & Type: Cub Cadet - Tank L (48" & 60"), Tank S (60"), Tank LZ (54" & 60"), Tank SZ (54" & 60")

Mower Tank L - 53AN2RTB050, 53AI2RTC050, 53AN2RTD050, 53AI2RTD050, 53AN2RTD009, 53YI2RTD050 / Tank S - 53RN2RUD050 / Tank LZ - 53AI2PTC050, 53BI2PTD050, 53YI2PTC050, 53YI2PTD050, 53BH2PTD330 /

Models: Tank SZ - 53AI2PUC050, 53BI2PUD050, 53YI2PUC050, 53YI2PUD050, 53RE2PUD050, 53AI2PUD330

Owner's Manual: Q0474

Vac/Drive Type: P3B (15 Cu. Ft.) PTO Driven

Revision #: 2 / Model Year Update (10/20/2014)

Fits Year(s): 2014-2015

LZ Mowers Require Weight Kit 59A30037150 (A1149) - Not Included On Pack

A1932 Vac Kit

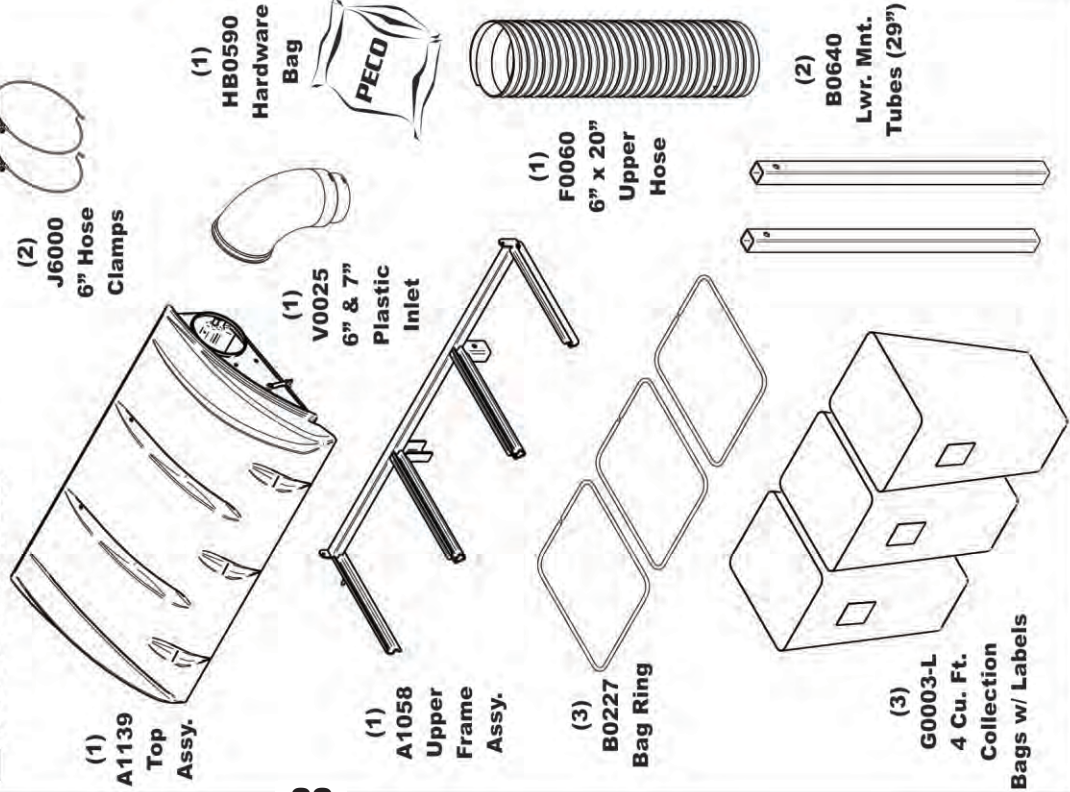

A1931 Mount Kit

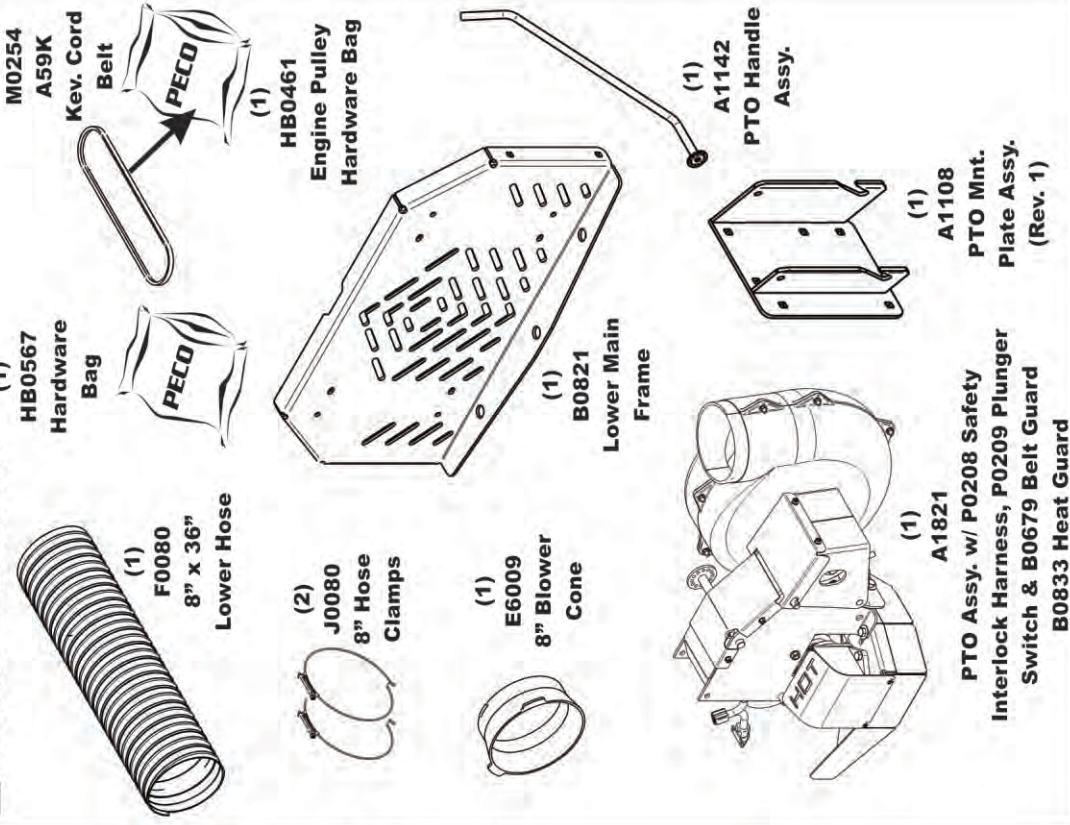

A1964 Boot Kit

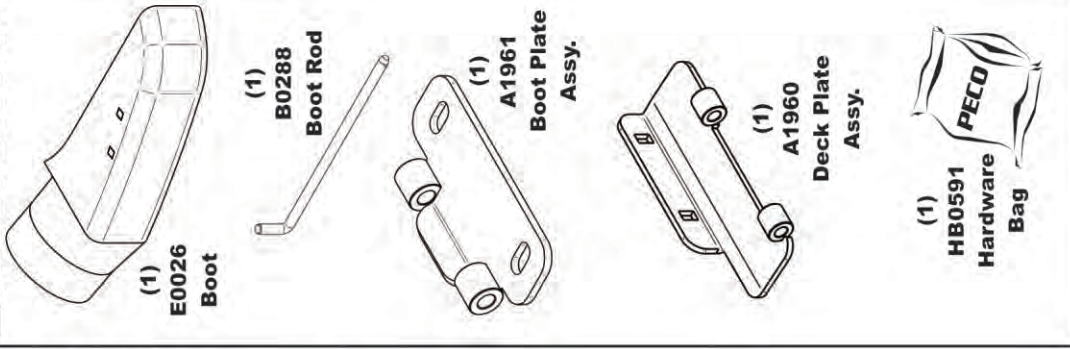

Wiring Diagram

P0208 Safety Interlock Wiring Harness

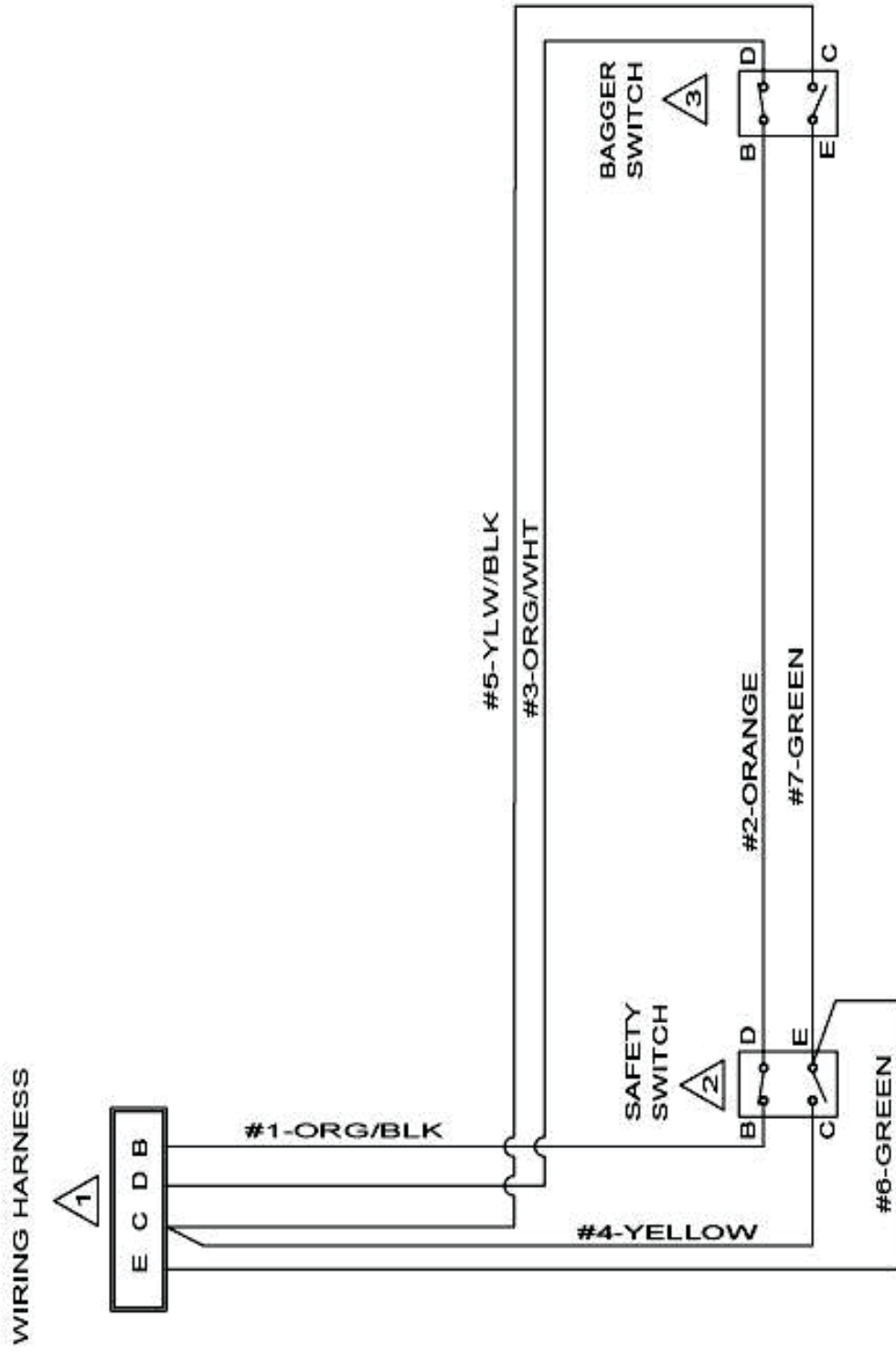

SECTION III OPERATING INSTRUCTIONS

3-1 General Safety

Only qualified people familiar with this operator's manual and the mower's operator's manual should operate this machine.

3-2 Operation And Tips On Mowing

- A. Perform BEFORE EACH USE the maintenance list in paragraph 4-1.
- B. Start mower.
- C. With the mower at high idle speed, engage the mower deck.
- D. While seated in the operator's seat, rotate the engagement handle of the collection system away from the mower. Continue to rotate the handle until it stops in an over center position. With the blower engaged, you can proceed to operate the control levers of the mower.

NOTE: If the collection system does not appear to be collecting the grass clippings, disengage the deck and blower, then, engage the parking brake and turn the mower off. Proceed to section 3-3, and review the section 2-5 and 2-6, in this manual.

To obtain the maximum effectiveness from your collection system the tips listed below should be followed:

- * Watch your speed- Normal conditions will allow a speed of up to approximately 5 mph, but thick, heavy damp conditions will require reduced ground speed.
- * Mow with sharp blades- A sharp blade cuts cleaner.
- * Wet grass and leaves will decrease effectiveness and will increase horsepower requirements.
- * Mow at higher cutting heights- Remove and mulch no more than 2" of grass length with each mowing. (Experts recommend not cutting off more than 1/3 of the grass blade length at any given time.)
- * Mow twice, at different height settings, (high, then low), if grass is extra tall.
- * Remember that horsepower requirements will vary with the mowing conditions such as type and height of turf grass, moisture content, amount of leaves, whether the terrain is flat or hilly, etc.

3-3 Disengagement Of The Blower

- A. To disengage the blower, rotate the engagement handle towards the mower.

WARNING: The blower will continue to spin. DO NOT TOUCH the blower, pulleys, or the belt until the tractor is turned off. DO NOT adjust the belt tension until the mower is turned off. Refer to section 2-5 of the manual.

3-4 Unloading The Collection System

NOTE: To determine when the collection bags are full, follow the following steps:

- A. Stop the forward movement of the mower.
- B. Disengage the mower deck.
- C. Disengage the blower.
- D. Engage the parking brake.
- E. Once the parking brake has been engaged, then and only then, walk behind the mower and check the collection bags by unlatching and lifting the top assembly. Load in bags should not exceed the height of the installed bag.
- F. To release bags, slide each bag out (towards operator) and turn bags over to deposit clippings.
- G. Return each bag to the original location, lower top assembly and re-latch to close .

NOTE: Do not allow collection bags to become over-filled as potential damage may occur to your equipment. Also, be sure to clean the hood screen as needed.

SECTION IV MAINTENANCE

4-1 Maintenance Checklist

NOTE: REMOVE PTO ASSEMBLY BEFORE RAISING DECK FOR MAINTENANCE.

Before each use:

1. Check blades and spindles to be sure that no foreign objects, such as wire or steel strapping bands, are wrapped around them.
2. Inspect blades for wear. Replace if necessary. If it is necessary to sharpen the blades, remove the blades from the spindles before sharpening. DO NOT sharpen blades while still attached to the mower.

3. Make sure all shields are in place and in good condition. Repair or replace any missing or damaged shields.
4. Perform lubrication per paragraph 4-2.
5. Listen for abnormal sounds, which might indicate loose parts, damaged bearings, or other damage. Correct any deficiency before continuing operation.
6. With the engine off, engage the blower assembly. Check the belt tension and inspect the pulley belt for cracks or tears.
7. Check for wear or deterioration of the upper or lower hoses. If there are any portions of the hose that have been torn or worn through, replace with genuine PECO parts.

After Each Use:

1. Clean all debris from machine especially from the container, underneath the belt shields, and safety decals. Replace any missing or illegible decals.
2. Inspect the unit for worn or damaged components. Repair or replace before the next use. Any replacement component installed during repair shall include the component's current safety decal specified by the manufacturers to be affixed to the component.
3. Check belt for proper tension.

4-2 Lubrication

NOTE: Use only white lithium based grease for lubrication of the shaft on the blower assembly.

1. On initial use: Grease the fitting on the blower shaft.
2. Every 25 hours of use: Re-grease the grease fitting.
3. Every 200 hours of use: Check oil levels in gear box. Oil in gear box should cover the gears. If necessary, fill using an EP90 weight oil. 6oz. will fill the gear box from empty.

SECTION V PARTS AND SERVICE

5-1 Parts And Service Information

PECO collection system owners should record the name and telephone number of their Service Center. Your Service Center will be happy to supply replacement parts, accessories, and do any service or repairs to your collection system. If for any reason your Service Center is unable to service your collection system or supply replacement parts, contact PECO and include the following information on the chart below.

THE SERIAL NUMBER PLATE IS LOCATED ON THE TOP ASSEMBLY

MODEL: 59A30044150

SERIAL: _____ **R0008**

WRITE THE MODEL AND SERIAL NUMBER IN THE BOX ABOVE FOR FUTURE REFERENCE.

Unit Model Number: _____
Unit Engine Size: _____
Unit Serial Number: _____
Date of purchase: ____/____/_____
Dealer/Distributor Name: _____
Address: _____ **State:** _____ **Zip:** _____
Phone Number: _____

SAFETY DECALS

To promote safe operation, PECO supplies safety decals on all products manufactured. Damage can occur to safety decals either through shipment, use or reconditioning. Contact your local Service Center for replacement decals.



Part #: R0006 - Cub Cadet Label



Part #: R1051
Warning: Hearing Protection Label

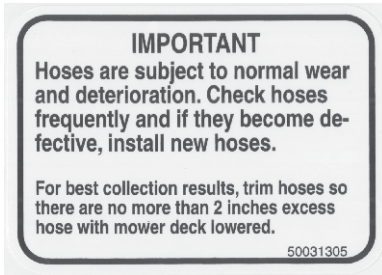

Part #: R1054
Important: Check Hoses Label



Part #: R4015
Danger: Rotating Blades Label



Part #: R1069
Warning: Turn Off Blower Label



Part #: R4008
Caution: Rotating Blades Label

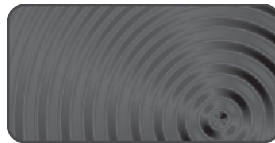
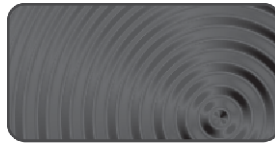

Part #: R1057
Red Reflector Label



Part #: R1065
Made In America Label



Part #: R1052
Small Warning: Turn Off Blower Label

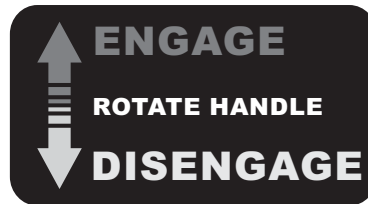

Part #: R1083
Engage/Disengage Label



Part #: R4037
Warning: Hot Surface Label



Part #: R2007
Danger: Never Use Hands Label

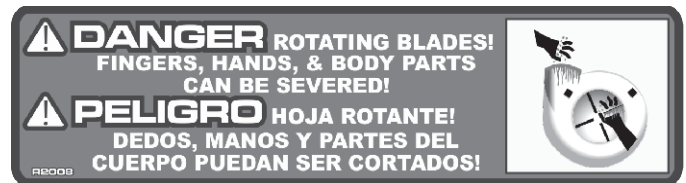

Part #: R2008
Danger: Rotating Blades Label

TORQUE SPECIFICATIONS

Proper torque for American fasteners used on Peco equipment.
Recommended Torque in Foot Pounds (Newton Meters).*

AMERICAN

Bolt Head Markings

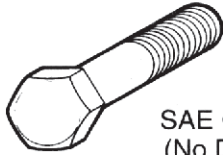

SAE Grade 2
(No Dashes)

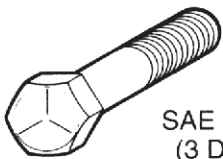

SAE Grade 5
(3 Dashes)

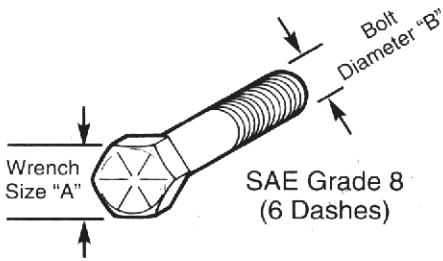

SAE Grade 8
(6 Dashes)

WRENCH SIZE (IN.) "A"	BOLT DIAMETER (IN.) "B" AND THREAD SIZE	SAE GRADE 2	SAE GRADE 5	SAE GRADE 8
7/16	1/4 - 20 UNC	6 (7)	8 (11)	12 (16)
7/16	1/4 - 28 UNF	6 (8)	10 (13)	14 (18)
1/2	5/16 - 18 UNC	11 (15)	17 (23)	25 (33)
1/2	5/16 - 24 UNF	13 (17)	19 (26)	27 (37)
9/16	3/8 - 16 UNC	20 (27)	31 (42)	44 (60)
9/16	3/8 - 24 UNF	23 (31)	35 (47)	49 (66)
5/8	7/16 - 14 UNC	32 (43)	49 (66)	70 (95)
5/8	7/16 - 20 UNF	36 (49)	55 (75)	78 (106)
3/4	1/2 - 13 UNC	49 (66)	76 (103)	106 (144)
3/4	1/2 - 20 UNF	55 (75)	85 (115)	120 (163)
7/8	9/16 - 12 UNC	70 (95)	109 (148)	153 (207)
7/8	9/16 - 18 UNF	79 (107)	122 (165)	172 (233)
15/16	5/8 - 11 UNC	97 (131)	150 (203)	212 (287)
15/16	5/8 - 18 UNF	110 (149)	170 (230)	240 (325)
1-1/8	3/4 - 10 UNC	144 (195)	266 (360)	376 (509)
1-1/8	3/4 - 16 UNF	192 (260)	297 (402)	420 (569)
1-5/16	7/8 - 9 UNC	166 (225)	430 (583)	606 (821)
1-5/16	7/8 - 14 UNF	184 (249)	474 (642)	668 (905)
1-1/2	1 - 8 UNC	250 (339)	644 (873)	909 (1232)
1-1/2	1 - 12 UNF	274 (371)	705 (955)	995 (1348)
1-1/2	1 - 14 UNF	280 (379)	721 (977)	1019 (1381)
1-11/16	1-1/8 - 7 UNC	354 (480)	795 (1077)	1288(1745)
1-11/16	1-1/8 - 12 UNF	397 (538)	890 (1206)	1444 (1957)
1-7/8	1-1/4 - 7 UNC	500 (678)	1120 (1518)	1817 (2462)
1-7/8	1-1/4 - 12 UNF	553 (749)	1241 (1682)	2013 (2728)
2-1/16	1-3/8 - 6 UNC	655 (887)	1470 (1992)	2382 (3228)
2-1/16	1-3/8 - 12 UNF	746 (1011)	1672 (2266)	2712 (3675)
2-1/4	1-1/2 - 6 UNC	870 (1179)	1950 (2642)	3161 (4283)
2-1/4	1-1/2 - 12 UNF	979 (1327)	2194 (2973)	3557 (4820)

METRIC

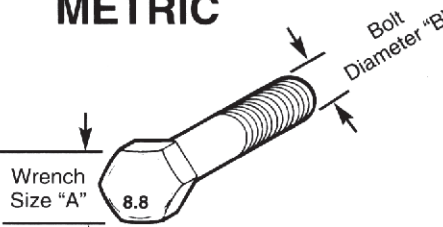

Numbers appearing on bolt heads indicate ASTM class.

Proper torque for metric fasteners used on Peco equipment.
Recommended torque in foot pounds (newton Meters).*

WRENCH SIZE (mm) "A"	BOLT DIA. (mm) "B"	ASTM 4.6	ASTM 8.8	ASTM 9.8	ASTM 10.9
8	5	1.8 (2.4)		5.1 (6.9)	6.5 (8.8)
10	6	3 (4)		8.7 (12)	11.1 (15)
13	8	7.3 (10)		21.1 (29)	27 (37)
16	10	14.5 (20)		42 (57)	53 (72)
18	12	25 (34)	74 (100)	73 (99)	93 (126)
21	14	40 (54)	118 (160)	116 (157)	148 (201)
24	16	62 (84)	167 (226)	181 (245)	230 (312)
30	20	122 (165)	325 (440)		449 (608)
33	22		443 (600)		611 (828)
36	24	211 (286)	563 (763)		778 (1054)
41	27		821 (1112)		1138 (1542)
46	30	418 (566)	1119 (1516)		1547 (2096)

*Use 75% of the specified torque value for plated fasteners. Use 85% of the specified torque values for lubricated fasteners.

NOTES

Cub Cadet®

Cub Cadet LLC

P.O. Box 361131
Cleveland, Ohio 44136-0019
Phone: 1-877-282-8684

MTD Products Limited

Kitchener, ON N2G 4J1
1-800-668-1238