



*DIXIE CHOPPER*  
**XT3**  
COLLECTION  
SYSTEM

DESIGNED FOR:

**Classic**

2960/3360

Model #: 38131504

60" Decks

**Xcaliber**

3366

Model #: 38131503

66" Decks



**OPERATOR'S MANUAL**

**ASSEMBLY • OPERATION • MAINTENANCE**

# XT GRASS COLLECTION SYSTEM

## TABLE OF CONTENTS

SECTION	PAGE	SECTION	PAGE
Safety	2	2-13 Upper Hose Installation	16
Safety Alert Symbols	3	2-14 Lower Hose To Blower Cone Installation	16
Warranty	4	2-15 Lower Hose To Boot Installation	16
I INTRODUCTION AND DESCRIPTION	5	2-16 Impeller Blade Removal and Replacement	17
1-1 Introduction	5	2-17 Weight Kit Installation	18
1-2 Description	5	2-18 Installation/Removal of Collection Bags	19
II INSTALLATION FOR USE	6	Exploded Part Views and Assemblies	20-24
2-1 Preparation Of Mower	6	III OPERATING INSTRUCTIONS	25
2-2 PTO Mount Plate Assembly Installation	7	3-1 General Safety	25
2-3 PTO Assembly Installation	8	3-2 Operation & Tips On Mowing	25
2-4 Belt Installation	9	3-3 Disengagement Of The Blower	25
2-5 Cam Assembly Adjustment	10	3-4 Unloading The Collection System	25
2-6 Blower Cone Installation	10	IV MAINTENANCE	25
2-7 Lower Main Frame & Lower Frame Assembly Installation	11	4-1 Maintenance Checklist	25-26
2-8 Upper Frame Assembly Installation	12	4-2 Lubrication	26
2-9 Top Assembly To Upper Frame Assembly Installation	13	V PARTS AND SERVICE	26
2-10 Hinge Kit Assembly Installation	13	5-1 Parts And Service Information	26
2-11 Boot To Mower Deck Installation	14-15	Safety Decals	27
2-12 Length Of Hose Adjustment	16	Torque Specifications	28

---

---

### **Safety**

1. Read the operator's manual carefully and familiarize yourself with the proper use of your attachment. Do not allow anyone who is not acquainted with the Safety Instructions to use your attachment.
2. Know the controls and how to stop quickly. READ THE OPERATOR'S MANUAL!
3. Do not allow children to operate the vehicle. Do not allow adults to operate it without proper instruction.
4. Be especially watchful of children and pets darting into the area while operating.
5. Keep your eyes and mind on your unit while mowing or operating your attachment. Don't let others distract you.
6. Do not attempt to operate your unit or mower when not in the driver's seat.
7. Always stop unit when emptying the container.
8. Stop unit, shut off deck attachment, set parking brake, shut off mower engine and remove spark plug wire before removing clogs, removing or replacing hose, boot, blower cone, or performing any maintenance.
9. Mow across the face of slopes (not steeper than 10 degrees); never up and down the face.
10. It is recommended that the container be kept only half full when negotiating any slopes. Start mowing on slopes when the container is empty.
11. Inspect your lawn and remove any foreign objects before mowing. Never deliberately run the mower across any foreign object.
12. Wear ear protection if the noise level is offensive.
13. Wear eye protection to prevent debris from damaging your eyes.

# SAFETY

**WARNING!** NEVER operate the mower unless the discharge guard and either the deflector assembly or the vacuum collector adapter are fastened securely in place.

**WARNING!** Do not work around the mower deck boot or the blower area until you are certain that the mower blades and the blower impeller have stopped rotating.

**WARNING!** To avoid serious injury, perform maintenance on the vacuum collector; **ONLY AFTER STOPPING THE MOWER'S ENGINE AND WAITING FOR ALL MOVING PARTS TO COME TO A COMPLETE STOP.** Set the parking brake. Always remove the ignition key before beginning maintenance.

**WARNING!** For your own personal safety, **ALWAYS** mow **ACROSS** the face of slopes and **NEVER UP and DOWN** the face. **NEVER** attempt to mow excessively steep slopes, and use caution when turning on any slope.

## Safety Alert Symbol



This Safety Alert Symbol means: **“ATTENTION! BECOME ALERT! YOUR SAFETY IS INVOLVED!”**

This symbol is used to call attention to safety precautions that should be followed by the operator to avoid accidents. When you see this symbol, carefully read the message that follows and heed its advice. Failure to comply with safety precautions could result in death or serious bodily injury.

## Safety Signs

The signal words **DANGER**, **WARNING**, and **CAUTION** are used on the equipment safety signs. These words are intended to alert the viewer to the existence and the degree of hazard seriousness.



White letters on **RED**

This signal word indicates a potentially hazardous situation which, if not avoided, will result in death or serious injury.



Black letters on **ORANGE**

This signal word indicates a potentially hazardous situation which, if not avoided, could result in death or serious injury.

It may also be used to alert against unsafe practices.



Black letters on **YELLOW**

This signal word indicates a potentially hazardous situation exist which, if not avoided, will result in minor or moderate injury.

It may also be used to alert against unsafe practices.

# DIXIE CHOPPER LIMITED WARRANTY FOR NEW PRODUCTS

## A. WHAT IS UNDER WARRANTY?

Dixie Chopper extends the following warranties to the original purchaser of each new Dixie Chopper consumer product subject to the following limitations.

- 1. PRODUCT WARRANTY:** Any part of any consumer product, which is defective in material or workmanship as delivered to the purchaser will be repaired or replaced, as Dixie Chopper elects, without charge for parts or labor, if the defect appears within 12 months from the date of delivery of the product to the original purchaser.  
**ALL DEFECTIVE PARTS MUST BE RETURNED TO DIXIE CHOPPER FOR INSPECTION TO DETERMINE VALIDITY OF WARRANTY CLAIMS.** Freight and mailing will be borne by the customer.
- 2. PARTS REPLACED DURING WARRANTY:** Any new Dixie Chopper part which is furnished in performance of this warranty and is defective in material or workmanship as delivered to the purchaser will be repaired or replaced, as Dixie Chopper elects, without charge if the defect appears within 90 days from the date of installation of such part or before the expiration of the original warranty period, whichever is later.

## B. SECURING WARRANTY ADJUSTMENTS.

All Warranty will be submitted by an Authorized Dixie Chopper Dealer directly to Dixie Chopper.

## C. ITEMS NOT COVERED BY DIXIE CHOPPER WARRANTY.

Engines and batteries attached to Dixie Chopper products are covered under a separate warranty by the respective manufacturer.

## D. UNAPPROVED ALTERATION OR MODIFICATION.

All obligations of Dixie Chopper under this warranty shall be terminated if products are altered or modified in ways not approved by Dixie Chopper.

## E. ACCIDENTS AND NORMAL MAINTENANCE.

The warranty covers only defective material and workmanship. It does not cover depreciation or damage caused by normal wear, accident, improper use or abuse of products. The cost of normal maintenance and normal replacement of service items such as belts, cutting blades, hoses, etc., which are not defective shall be paid for by the purchaser.

## F. NO REPRESENTATIONS ADDITIONAL WARRANTIES, DISCLAIMER.

Neither Dixie Chopper nor any company affiliated with it makes any warranties, representations or promises as to the quality of performance of its products other than those set forth herein. Except as described above, Dixie Chopper makes no other warranties **AND SPECIFICALLY DISCLAIMS ANY AND ALL IMPLIED WARRANTIES OF FITNESS AND MERCHANTABILITY.**

## G. ANY MACHINE USED FOR RENTAL PURPOSES ARE GUARANTEED FOR 45 DAYS FROM DATE OF ORIGINAL SALE ONLY.

## H. REMEDIED EXCLUSIVE.

The only remedies the purchaser has in connection with the breach or performance of any warranty on Dixie Chopper consumer products are set forth above. In no event will Dixie Chopper be liable for special incidental or consequential damages.

## 1. NO SERVICE CENTER WARRANTY.

The selling Service Center makes no warranty on his own on any item warranted by Dixie Chopper unless he delivers to purchaser a separate written warranty certificate specifically warranting the item. The dealer has no authority to make any representation or promise on behalf of Dixie Chopper or to modify the terms of this warranty in any way.

## 2-2 PTO Mount Plate Assembly

### Installation

Position the PTO mount plate assembly P#(A1871) on the right rear frame of the mower as shown in Figure 2-2a. Secure the PTO mount plate assembly R.O.P.S. using (1) 3/8"-16 x 2-1/8" x 2-5/8" P#(K1119) and (2) 3/8"-16 nylon flange lock nuts P#(K2038). Secure the PTO mount plate assembly to the rear frame of the mower using (2) 3/8"-16 x 1" x 1" u-bolt P#(K1118) and (4) 3/8"-16 nylon flange locknuts P#(K2038).

Insert exhaust diverter P#(J0282) into slots and secure using clamp kit P#(X1064).

Figure 2-2a

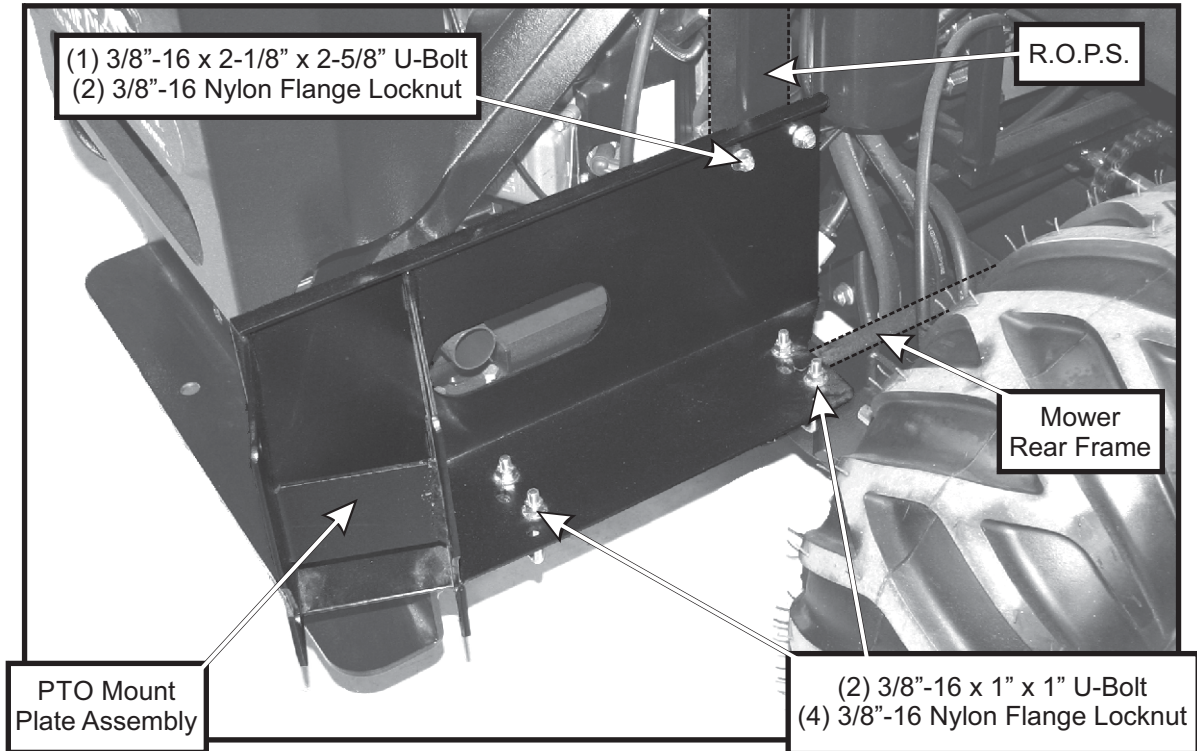
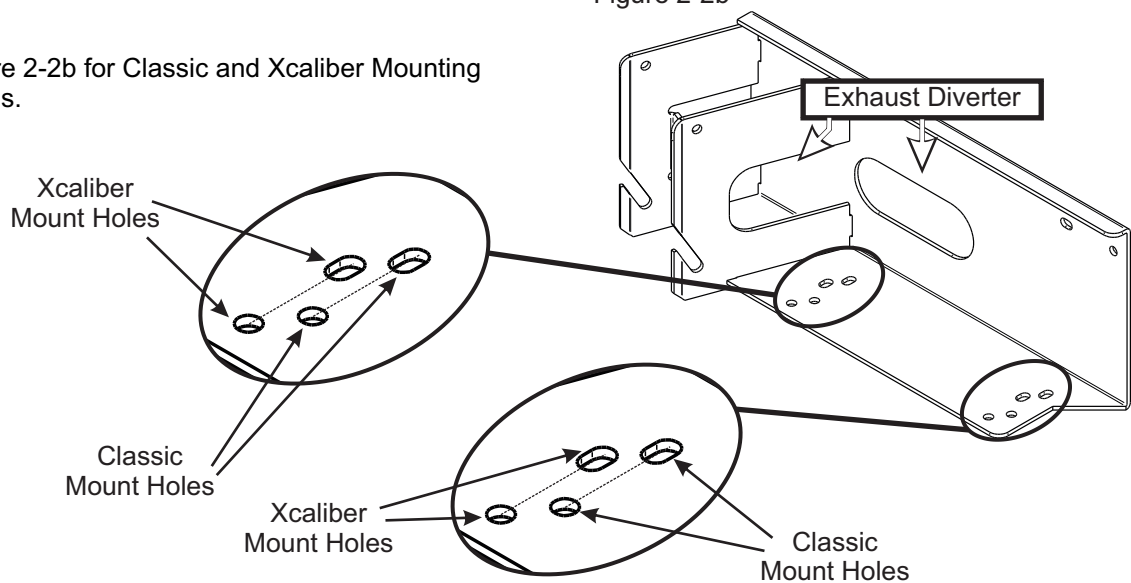

Figure 2-2b

Refer to Figure 2-2b for Classic and Xcaliber Mounting Hole Locations.



# Section I - INTRODUCTION AND DESCRIPTION

## 1-1 Introduction

Your collection system has been designed to give you a low maintenance, simple, and effective way to collect the grass clippings from your mower. This manual is provided to give you the necessary instructions to properly mount and operate the collection system on your mower. Please read this manual thoroughly. Understand what each control is for and how to use it. Observe all safety decal precautions on the machine and noted throughout the manual.

**NOTE:** all references made to right, left, front, rear, top or bottom are as viewed from the normal operator's position on the mower.

## 1-2 Description

The grass collection system is designed for turf maintenance where there is a need to collect the grass clippings as the mower cuts the turf. It is also used for picking up leaves and in pre-season and post-season clean-up. The blower, mounted on the right side of the unit, uses a belt and gearbox system from the engine PTO shaft. Drive train protection comes through belt slippage. The blower draws grass clippings from the discharge area of the cutter deck back to the (3) - 4 cubic foot collection bags P#(G0003) at the rear portion of the mower frame. The operator can engage the blower with a push of the over-center linkage on the right side of the unit. Once the bags are full with clippings, they can be released to make for easy dumping.



## Section II - INSTALLATION FOR USE

### 2-1 Preparation Of Mower

**NOTE:** The mower deck PTO belt must be removed from the electric clutch before continuing with the installation. Refer to your Dixie Chopper mower owner's manual for instructions on PTO belt removal.

From the underside of the engine, disconnect the wiring harness attached to the electric clutch. Remove the bolt and electric clutch from the mower. Refer to Figure 2-1a.

Figure 2-1a

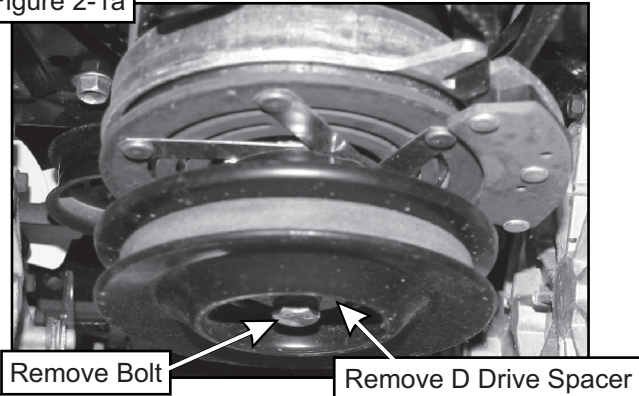

Remove the D-drive spacer using an arbor press or equivalent. On removal, adjacent bearing OUTER race must be supported or bearing damage may occur. Refer to Figure 2-1b.

Figure 2-1b

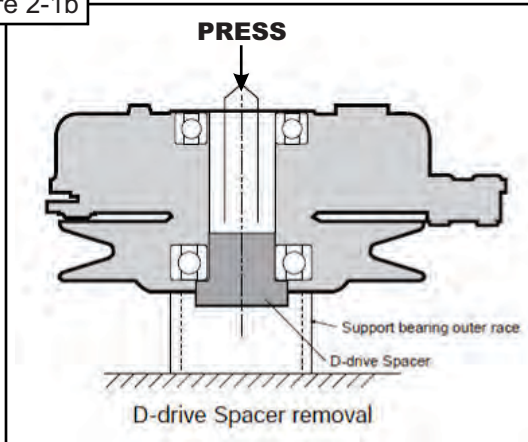
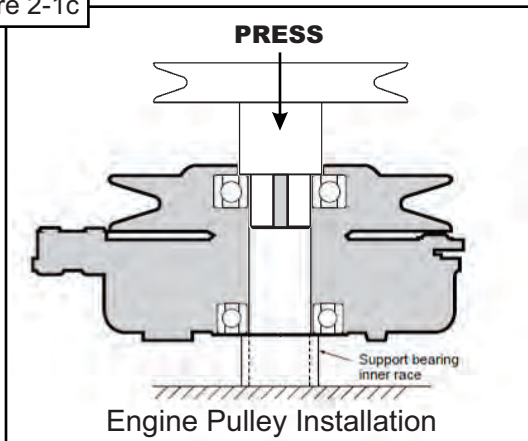

Figure 2-1c



The engine pulley assembly must be installed using an arbor press or equivalent. During installation, opposite bearing inner race must be supported or bearing damage may occur. Refer to Figure 2-1c.

Upon pressing the engine pulley to the clutch, replace the completed assembly to the mower's engine shaft to fasten.

Figure 2-1d

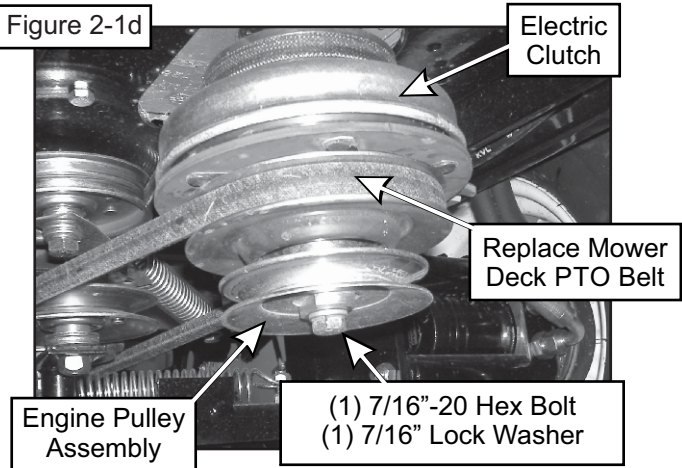

#### **27HP Generac & 29HP Kohler**

Fasten engine pulley assembly number 18 P#(A1109) to the electric clutch using (1) 7/16"-20 x 4" HHCS P#(K0359) and (1) 7/16" helical spring lock washer P#(K0140). Refer to Figure 2-d for reference.

#### **33HP Generac**

Fasten engine pulley assembly number 23 P#(A1175) to the electric clutch using (1) 7/16"-20 x 3-3/4" HHCS P#(K0350) and (1) 7/16" helical spring lock washer P#(K0140). Torque the bolt to 55ft./lbs. Refer to Figure 2-1d for reference.

**NOTE:** On Classic and Xcaliber models, the PTO belt included in the hardware bag must be positioned behind the clutch before the engine pulley is installed. Refer to Figure 2-1e.

Figure 2-1e

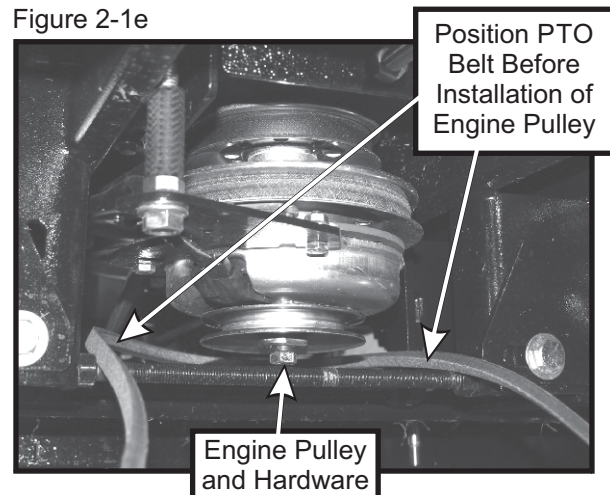

## 2-3 PTO Assembly Installation

Insert the PTO assembly P#(A1623) into the mounting slots on the PTO mount plate assembly. Secure the PTO assembly with (1) PTO mount pin P#(B0274) and (1) hair pin clip P#(K0086). Refer to Figure 2-3.

Attach the PTO handle assembly P#(A1142) to the PTO assembly using (3) 1/4"-20 x 3/4" HHCS and P#(K1222) (3) 1/4"-20 nylon flange locknuts P#(K2014). Refer to Figure 2-3.

**NOTE:** Remove the PTO belt guard and hardware, in preparation for the belt installation.

Figure 2-3

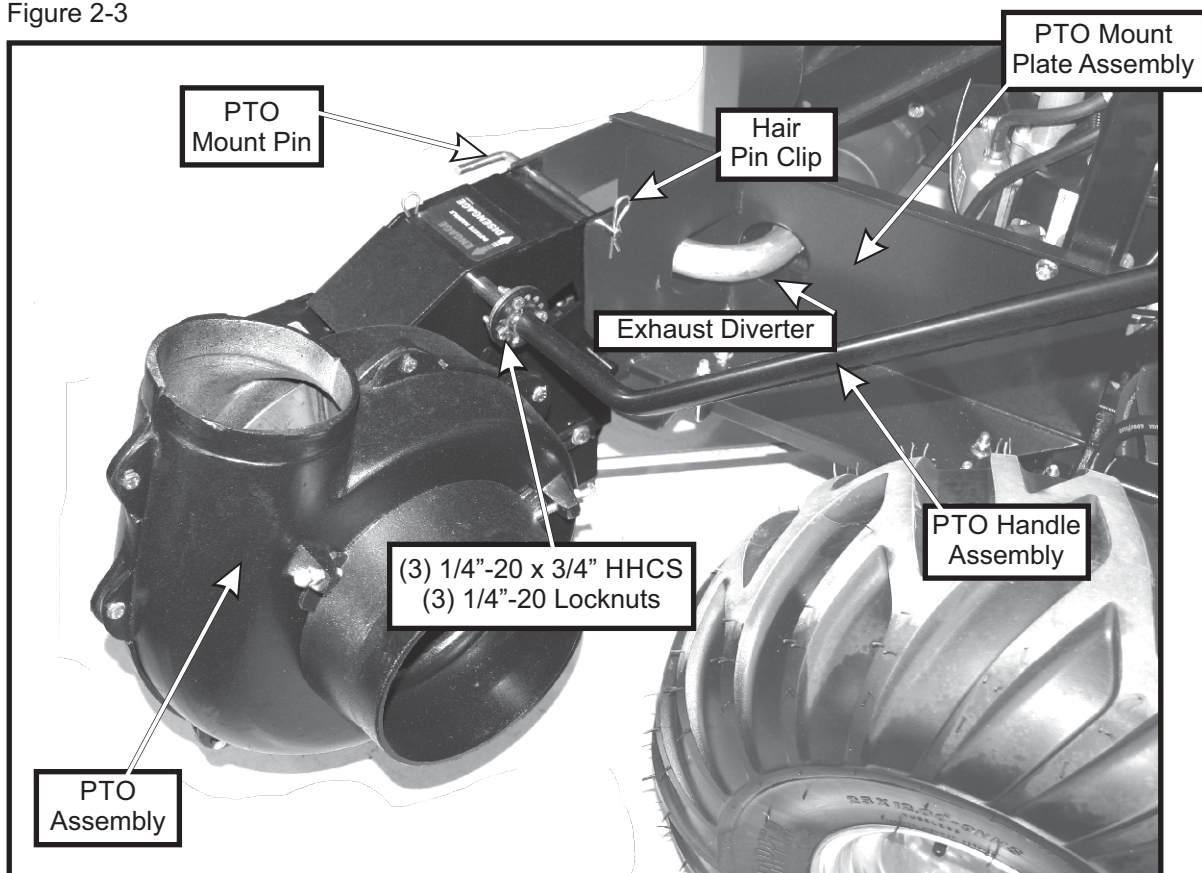



## 2-4 Belt Installation and Adjustment

Loosen the (4) bolts P#(K1191), (2) on each side, that secure the gear box assembly to the PTO assembly P#(A1803) (Figure 2-4a and 2-4b).

Figure 2-4a

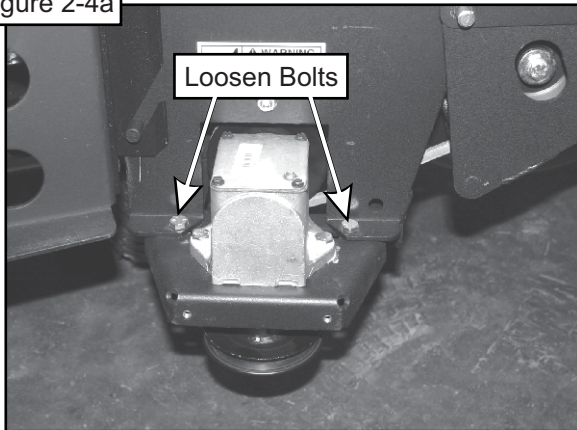
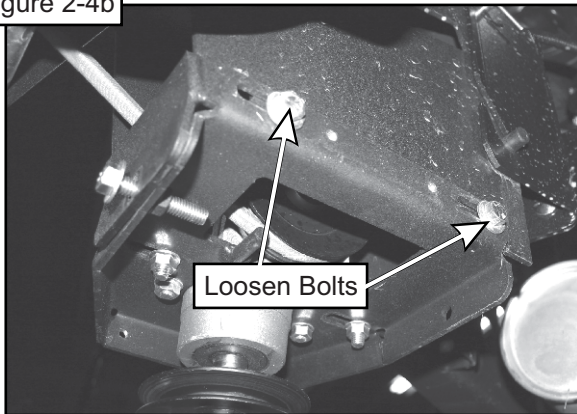
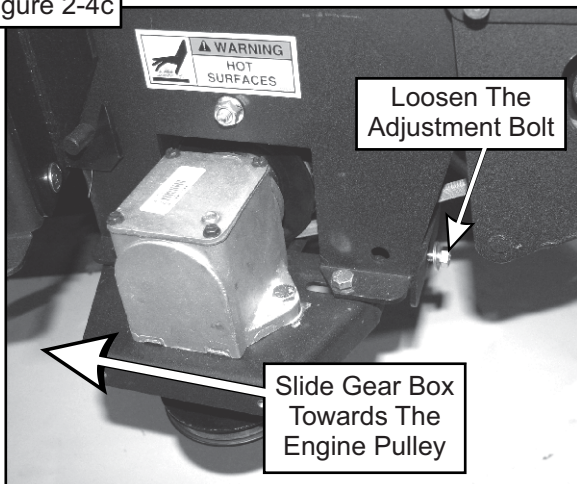

Figure 2-4b



Loosen the adjustment bolt P#(K0348) until the gear box assembly is at its far left adjustment (the gear box is moved toward the mower's engine pulley). Refer to Figure 2-4c.

Figure 2-4c



Connect the kevlar cord belt 78" P#(M0274) from the engine pulley to the lower gear box pulley (Figure 2-4d).

Figure 2-4d

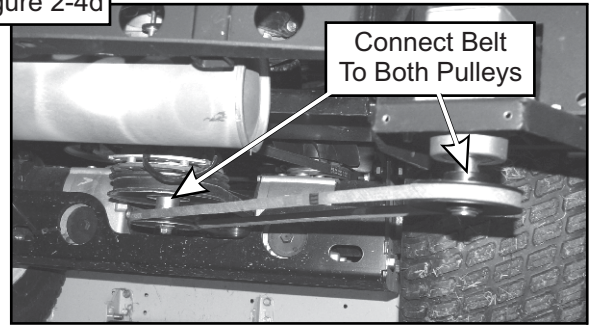

To tension the drive belt, turn the adjustment bolt clockwise (Figure 2-4e) until there is 1" of deflection, with 10-11 lbs. of pressure, at the center of the belt between the engine pulley and the gear box pulley.

Figure 2-4e

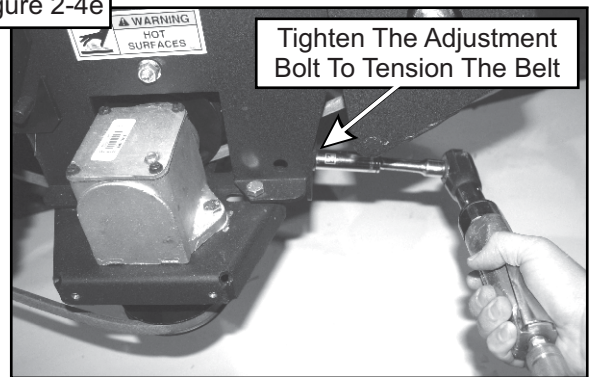

Once the correct tension of the belt is achieved, tighten the (4) bolts that secure the gear box assembly. Refer to Figures 2-4f and 2-4g. Replace the belt guard and hardware that was removed in Section 2-3.

Figure 2-4f

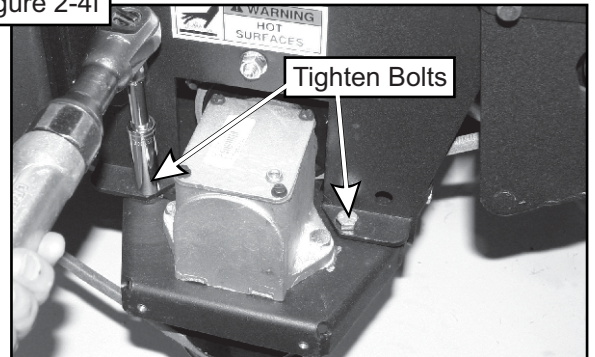
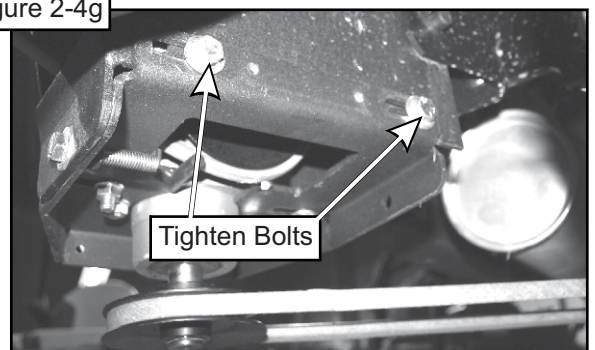

Figure 2-4g



## 2-5 Cam Assembly Adjustment

The cam assembly P#(A0422), which controls the blower belt tension, comes from the factory pre-adjusted. If the belt is too tight or becomes too loose, remove the hair pin clip P#(K0099) from the belt tension rod P#(K0326) and pull the "L" end of the rod out of its hole in the cam assembly. The tension rod may then be screwed out to tighten the belt or screwed in to loosen the belt. Replace the "L" end into the top hole in the cam and replace the hair pin clip. Adjust the cam stop bolt P#(K1159) to allow the cam to rotate slightly over center when the blower is disengaged (Figure 2-5).

Figure 2-5

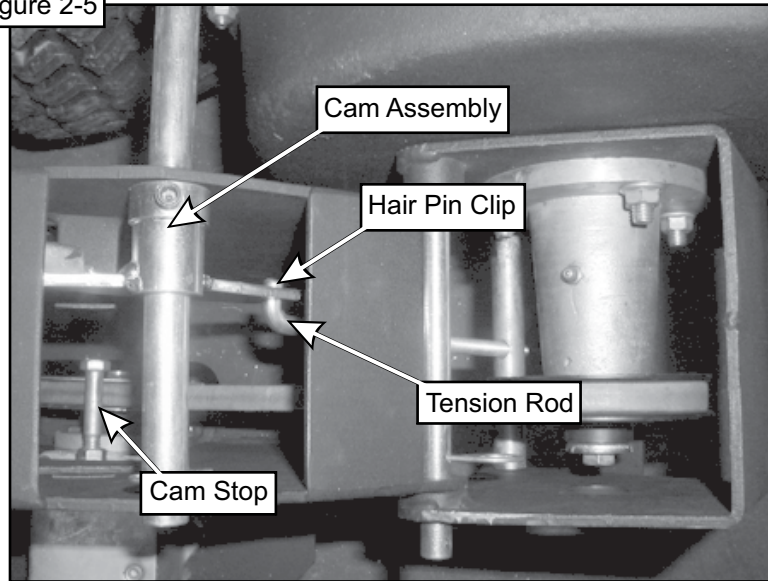

## 2-6 Blower Cone Installation

Thread (1) 5/16"-18 jam nut P#(K0120) onto each end of (2) 5/16"-18 x 2-1/2" HHCS P#(K0125). Now partially thread the bolts into each of the two tabs located on the blower housing. Place blower cone so the two tabs line up with the bolts then tighten completely. See Figure 2-6.

Figure 2-6

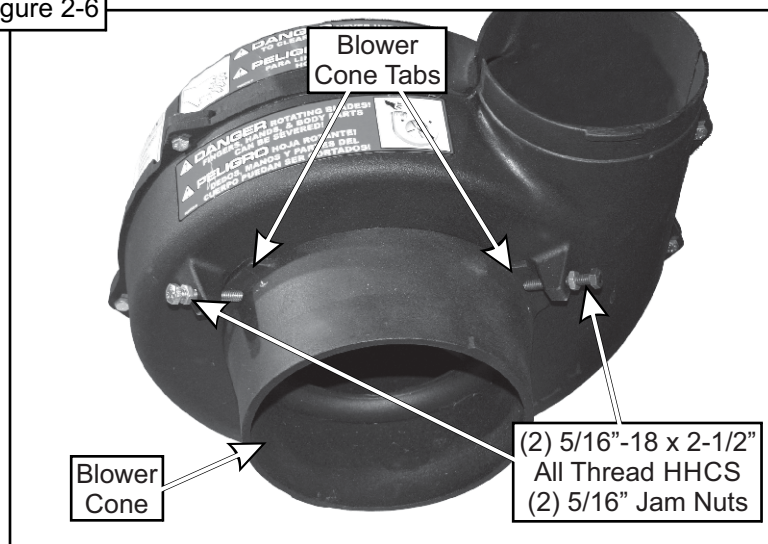

## 2-7 Lower Main Frame and Lower Frame Assembly Installation

Secure the lower main frame P#(B0567) to the R.O.P.S using (2) 3/8"-16 x 2-1/8" u-bolts P#(K1119) and (4) 3/8"-16 nylon flange locknuts P#(K2038) as shown in Figure 2-7a.

Position the lower frame assembly P#(A1872) as shown in Figure 2-7b. Secure the lower frame assembly to the lower main frame using (2) 1/2"-13 x 1-1/4" HHCS P#(K1232) and (2) 1/2"-13 nylon flange locknuts P#(K2012). Secure the lower frame assembly to the rear face of the lower main frame using (2) 3/8"-16 x 1" HHCS P#(K1191) and (2) 3/8"-16 nylon flange locknuts P#(K2038). Refer to Figure 2-7b.

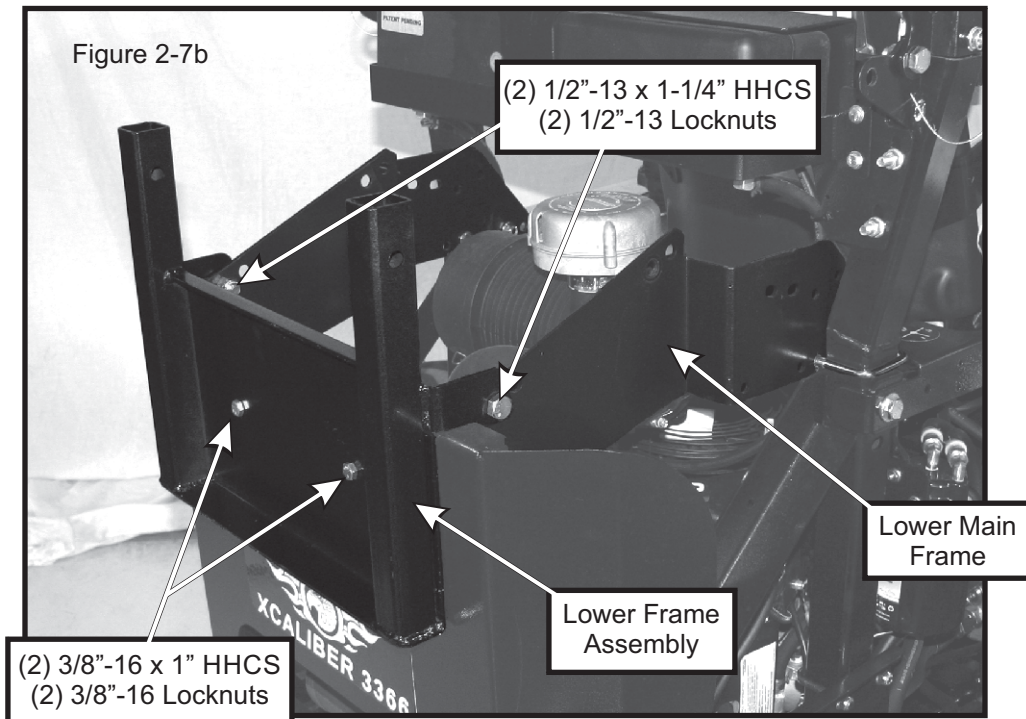
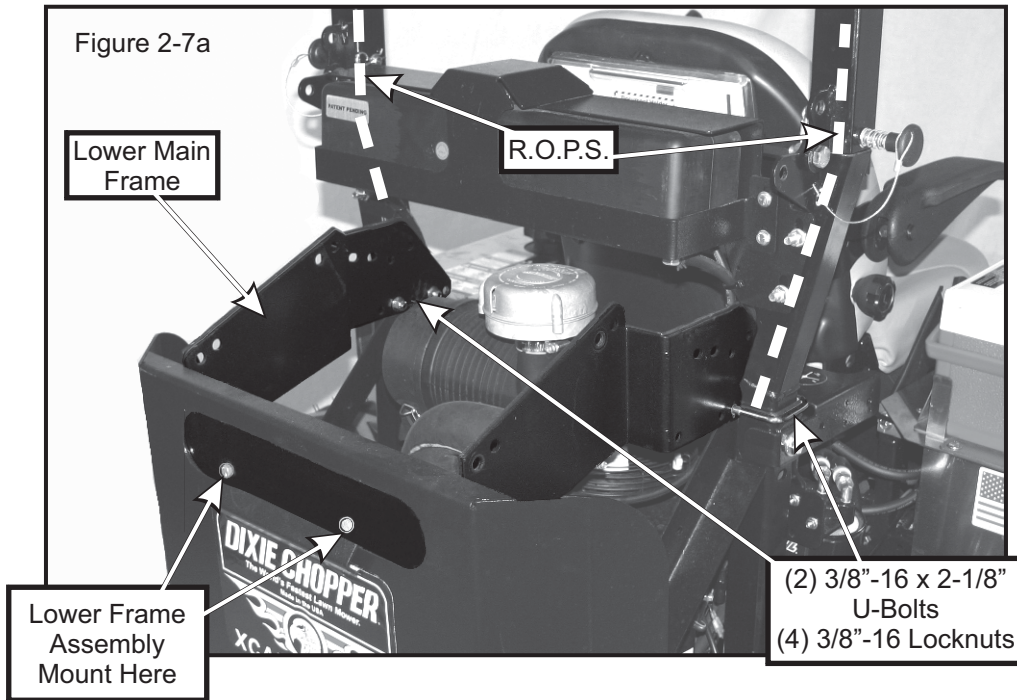

## 2-8 Upper Frame Assembly Installation

**NOTE:** During this step, it is suggested that two people install the upper frame to the lower mount tube.

Lift the upper frame assembly P#(A1058) above the lower frame assembly and lower the top assembly onto the two vertical tubes. Secure the top assembly to the lower mount assembly using (2) clevis pins P#(K0133) and (2) hair pin clips P#(K0088). Refer to Figure 2-8.

Figure 2-8

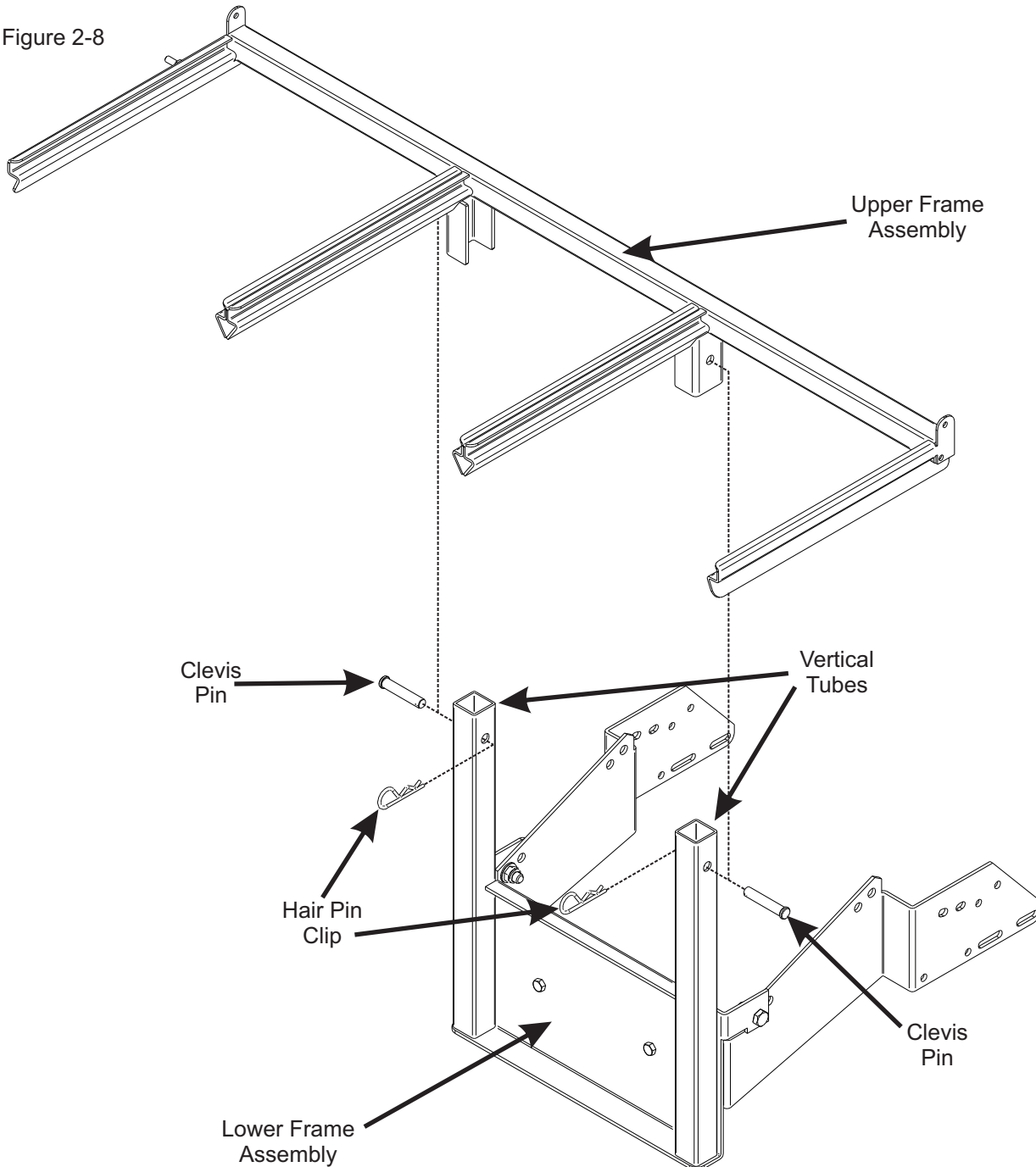

## 2-9 Top Assembly To Upper Frame

### Assembly Installation

Position the top assembly P#(A1187) above the upper frame assembly as shown in Figure 2-9. Fasten the top assembly to the upper frame assembly using (2) 5/16"-18 x 2-1/2" HHCS P#(K0125) and (2) 5/16"-18 nylon flange locknuts P#(K2516). Leave the locknuts slightly loose, to allow the top assembly to open and close easily. Refer to Figure 2-9 for hardware location.

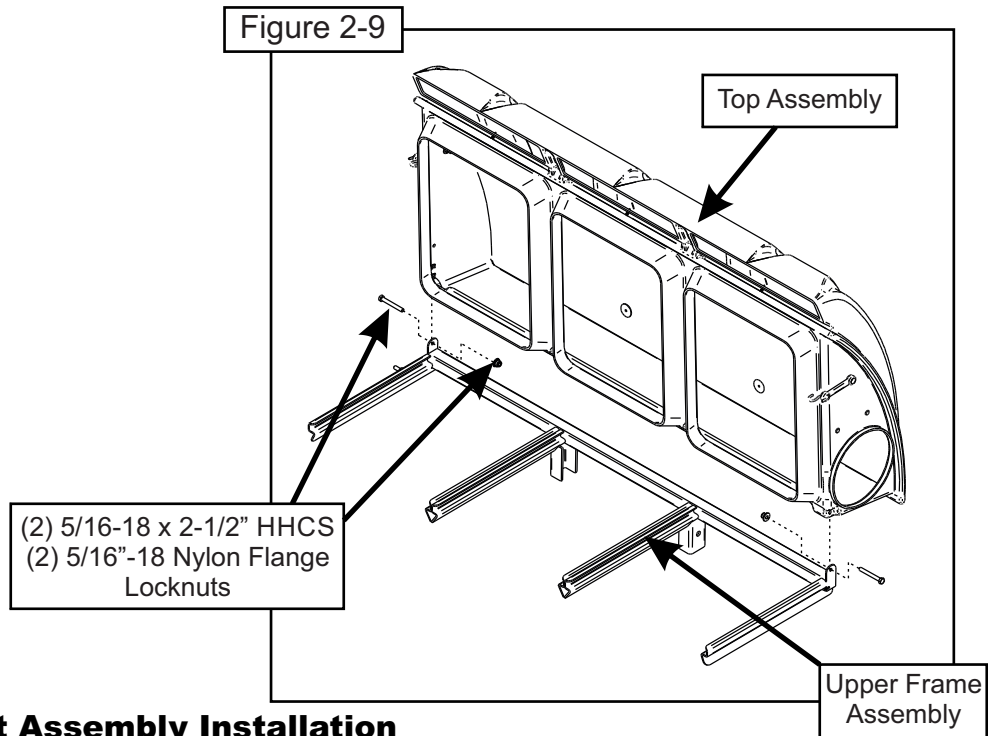

## 2-10 Hinge Kit Assembly Installation

Assemble the hinge kit as shown in Figure 2-10, using (2) 5/16"-18 x 1" HHCS P#(K1154), (3) 5/16"-18 nylon flange locknuts P#(K2516), (5) 1/4" flat washers P#(K0037) and (2) swing arm brackets P#(ZT-0004). Place (1) vinyl cap P#(J0289) on the end of the hex bolts as shown in Figure 2-10. Leave the nuts loose enough to allow fluid movement of the top when opening and closing. When opened, the top should rest on the middle joint of the hinge allowing it to remain up.

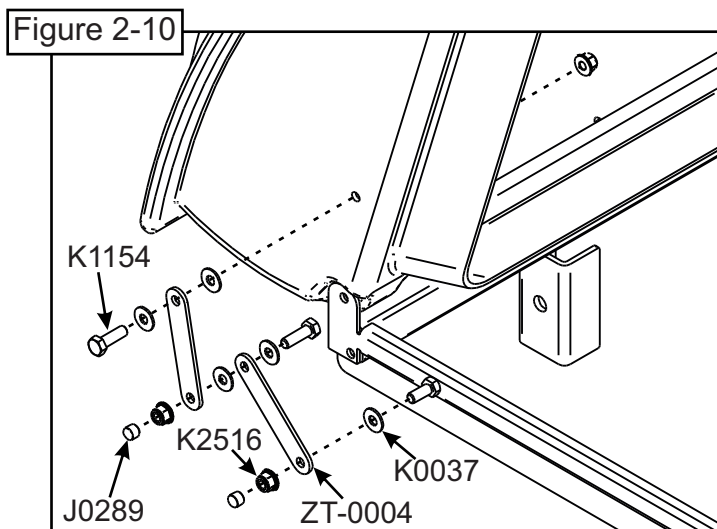

## 2-11 Boot To Mower Deck Installation

**NOTE:** Remove all grass deflector and/or mulching hardware from the mower deck before proceeding.

### Classic 50" & 60" Models

Position the boot plate P#(B0775) onto the top of the aluminum boot P#(E0023) as shown in Figure 2-11a. Secure the boot plate to the boot using (2) 3/8"-16 x 1" carriage bolts P#(K1182) and (2) 3/8"-16 nylon flange locknuts P#(K2038). Insert the bolts from the inside of the boot so that the lock nuts are on top of the boot plate. This will prevent grass clipping from collecting on the bolt threads. Position the deck mount plate onto the top of the mower deck as shown in Figure 2-11a. Secure the deck mount plate to the mower deck using (2) 3/8"-16 x 1" carriage bolts P#(K1182) and (2) 3/8"-16 nylon flange locknuts P#(K2038). Insert the bolts from the underside of the mower deck.

**NOTE:** Do not tighten hardware until boot has been installed to mower deck.

Figure 2-11a

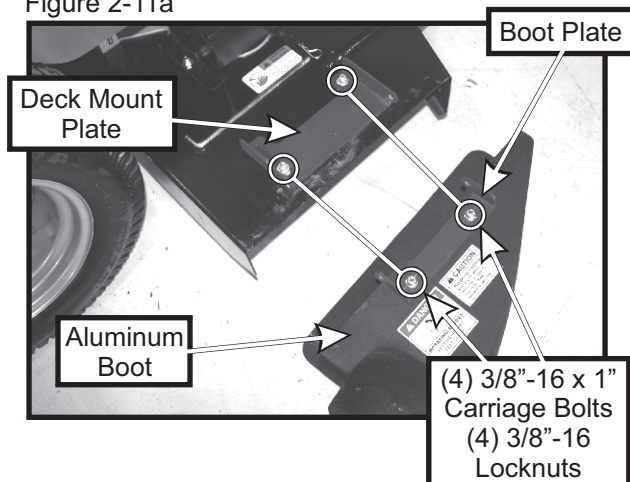

### Classic Boot Plate Mounting Locations

Refer to Figure 2-11b for Classic boot plate mounting locations.

Figure 2-11b

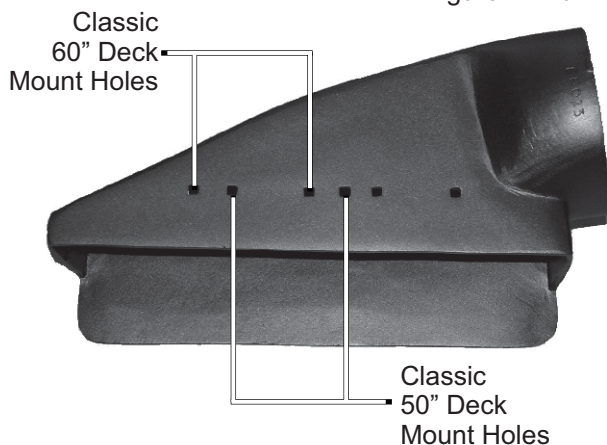

### Classic Deck Plate Mounting Locations

Refer to Figure 2-11c for Classic deck plate mounting locations.

Figure 2-11c

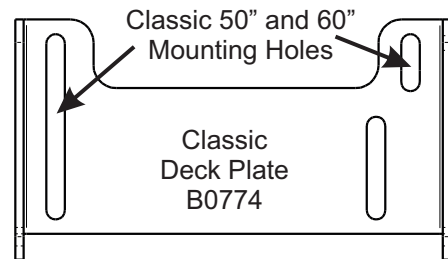

Align the holes in the boot plate with the holes in the deck mount plate. Insert the boot rod P#(B0333) into the mounting holes and secure with (1) hair pin clip P#(K0099). Refer to Figure 2-11d.

With all the carriage bolts still finger tight, use the slots in the deck mount plate and the boot plate to position the boot so that the front inside corner of the boot is flush to the front outside edge of the mower deck. Also check for clearance between the mowers blade and the bottom edge of the boot. Once the boot is positioned correctly, tighten all the hardware.

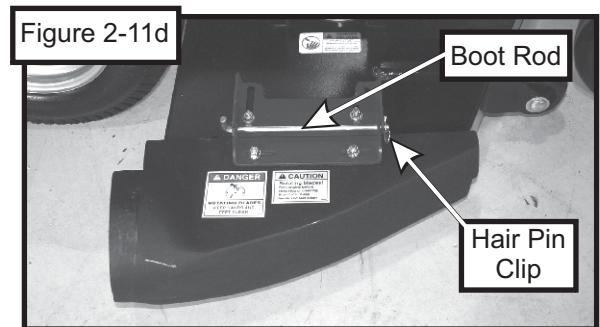

## 2-11 Boot To Mower Deck Installation Continued

**NOTE:** Remove all grass deflector and/or mulching hardware from the mower deck before proceeding.

### Xcaliber 66" Models

Position the boot plate P#(B0783) onto the top of the aluminum boot P#(E0023) as shown in Figure 2-11e. Secure the boot plate to the boot using (2) 3/8"-16 x 1" carriage bolts P#(K1182) and (2) 3/8"-16 nylon flange locknuts P#(K2038). Insert the bolts from the inside of the boot so that the lock nuts are on top of the boot plate. This will prevent grass clipping from collecting on the bolt threads. Position the deck mount plate P#(B0776) onto the top of the mower deck as shown in Figure 2-11e. Secure the deck mount plate to the mower deck using (2) 3/8"-16 x 1" carriage bolts P#(K1182) and (2) 3/8"-16 nylon flange locknuts P#(K2038). Insert the bolts from the underside of the mower deck.

**NOTE:** Do not tighten hardware until boot has been installed to mower deck.

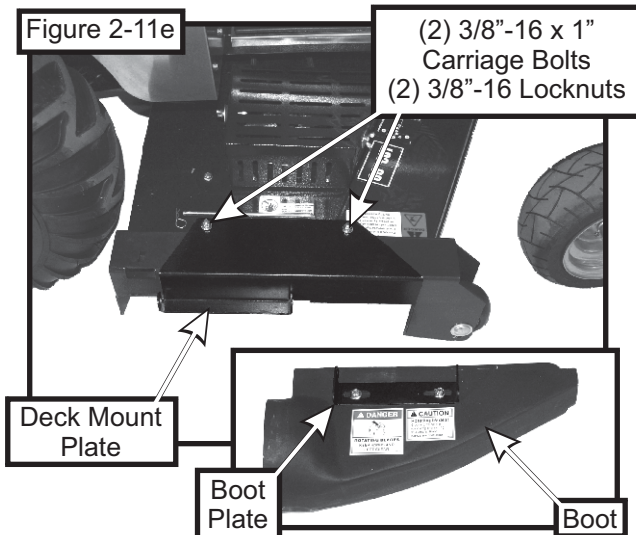

### Xcaliber Boot Plate Mounting Locations

Refer to Figure 2-11f for Xcaliber boot plate mounting locations.

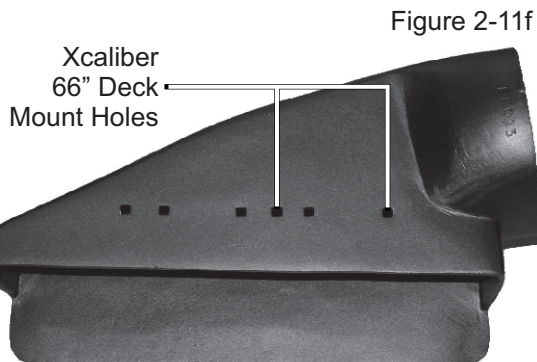

Align the holes in the boot plate with the holes in the deck mount plate. Insert the boot rod P#(B0333) into the mounting holes and secure with (1) hair pin clip P#(K0099). Refer to Figure 2-11g.

With all the carriage bolts still finger tight, use the slots in the deck mount plate and the boot plate to position the boot so that the front inside corner of the boot is flush to the front outside edge of the mower deck. Also check for clearance between the mowers blade and the bottom edge of the boot. Once the boot is positioned correctly, tighten all the hardware.

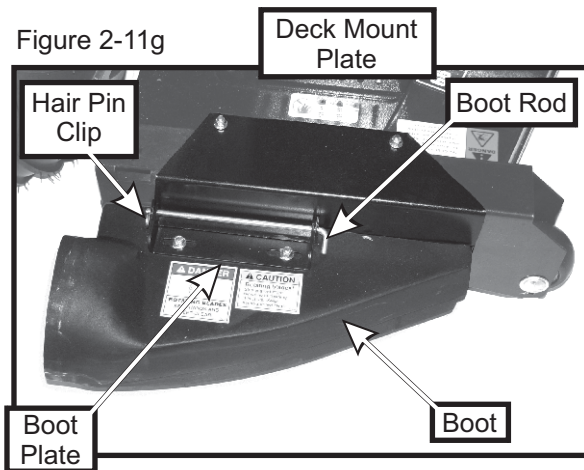

## 2-12 Length Of Hose Adjustment

The hoses in steps 2-13 and 2-14 must be cut to fit your machine. Follow steps 2-13 and 2-14. Do not cut the hoses until you have tried to fit them on your machine. Remember that the hoses have to be long enough to adjust for the blower assembly's movement as well as allow for enough clamping surface between the inlet, blower assembly, and the deck boot.

## 2-13 Upper Hose Installation

Fasten the inlet to the plastic top by sliding the inlet from the inside of the top to the outside and lock into place. Slide a pre-assembled hose clamp P#(J0060) onto both ends of the 6" upper hose (Figure 2-15). Then slide one end of the 6" hose onto the inlet. Make sure there is about a two-inch overlap between the hose end and the container inlet. Proceed to slide the opposite end of the 6" hose onto the outlet of the blower assembly. See (Figure 2-15) for details. Make sure both ends of the hose are clearly attached to the inlet and the blower assembly inlet. Tighten the hose clamps.

## 2-14 Lower Hose To Blower Cone Installation

Slide a pre-assembled hose clamp P#(J0080) over both ends of the lower hose. Then proceed to slide the lower hose onto the blower cone. Tighten the hose clamp. The assembly should look like Figure 2-15.

## 2-15 Lower Hose To Boot Installation

Take the unattached end of the lower hose and slide it over the circular end of the boot. Use the lower hose clamp to secure the hose to the boot (Figure 2-15). Tip: Before securing clamp rotate hose counter-clockwise (away from yourself) approximately 1" to aid in retaining boot to mower deck.

Figure 2-15

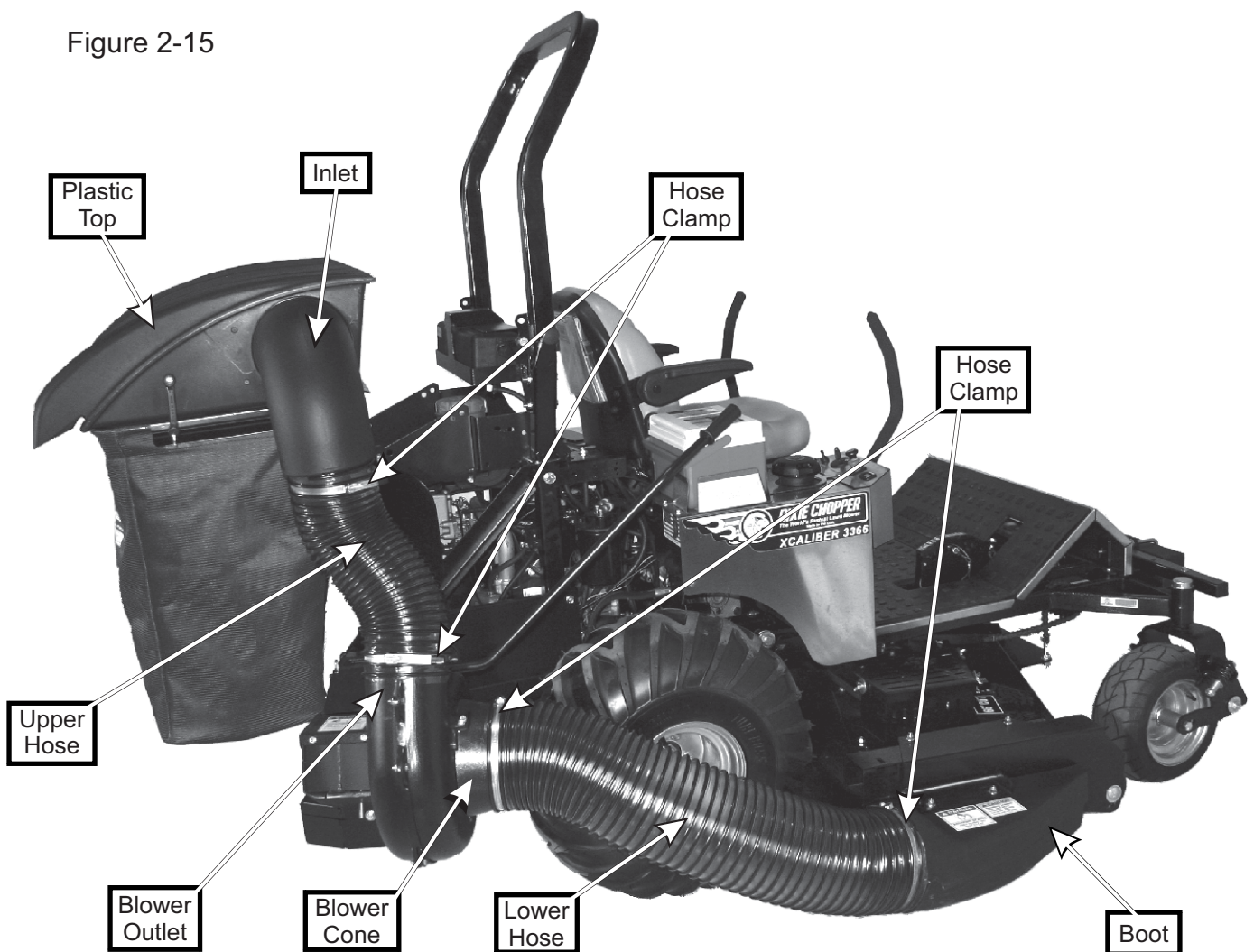



## 2-16 Impeller Blade Removal/Replacement

To gain impeller blade (#1) access, first remove the blower cone (#2) from the blower housing, located on the PTO assembly P#(A1821), by removing two blower cone bolts and nuts (#3). Next, remove the blower housing front (#4) by removing seven bolts and nuts (#5) around the outer housing edge. Refer to Figure 2-16.

**To Remove:** First, remove one 3/8"-16 x 1-1/2" HHCS P#(K1211) (#6), one taper-lock bushing washer P#(K0278) (#7) and one spacer bushing P#(S3242) (#8) from the taper-lock bushing (#9). See Figure 2-16. Next, remove two 1/4"-20 x 1" HHCS (#10) and place them into the threaded holes (#11) of the taper-lock bushing P#(S4302). Last, gradually thread each bolt evenly into the taper-lock bushing, forcing the blade to break-away from the taper-lock bushing.

### Tips on removing impeller blade;

- 1 - Try carefully hitting the base of the impeller blade (#1), between each vein (#12), with a rubber mallet to loosen the taper-lock bushing hold.
- 2 - Spray break-free lubricant into the surrounding areas of the taper-lock bushing (#9) and repeat Tip 1.

**To Replace:** First, place the impeller blade (#1) over the drive shaft (#13). Next, slide the taper-lock bushing (#9) on to the drive shaft and into the impeller blade, aligning the **non-threaded** holes (#14) of the taper-lock bushing to the threaded holes of the impeller blade. Then, fasten by using two 1/4"-20 x 1" HHCS (#10), one spacer bushing (#8) one taper lock bushing washer (#7), and one 3/8"-16 x 1-1/2" HHCS (#6). Torque all bolts to the specifications located in the chart towards the back of this manual. Last, rotate the impeller blade to ensure that the blade is clear of contact on all sides of the blower housing.

Figure 2-16

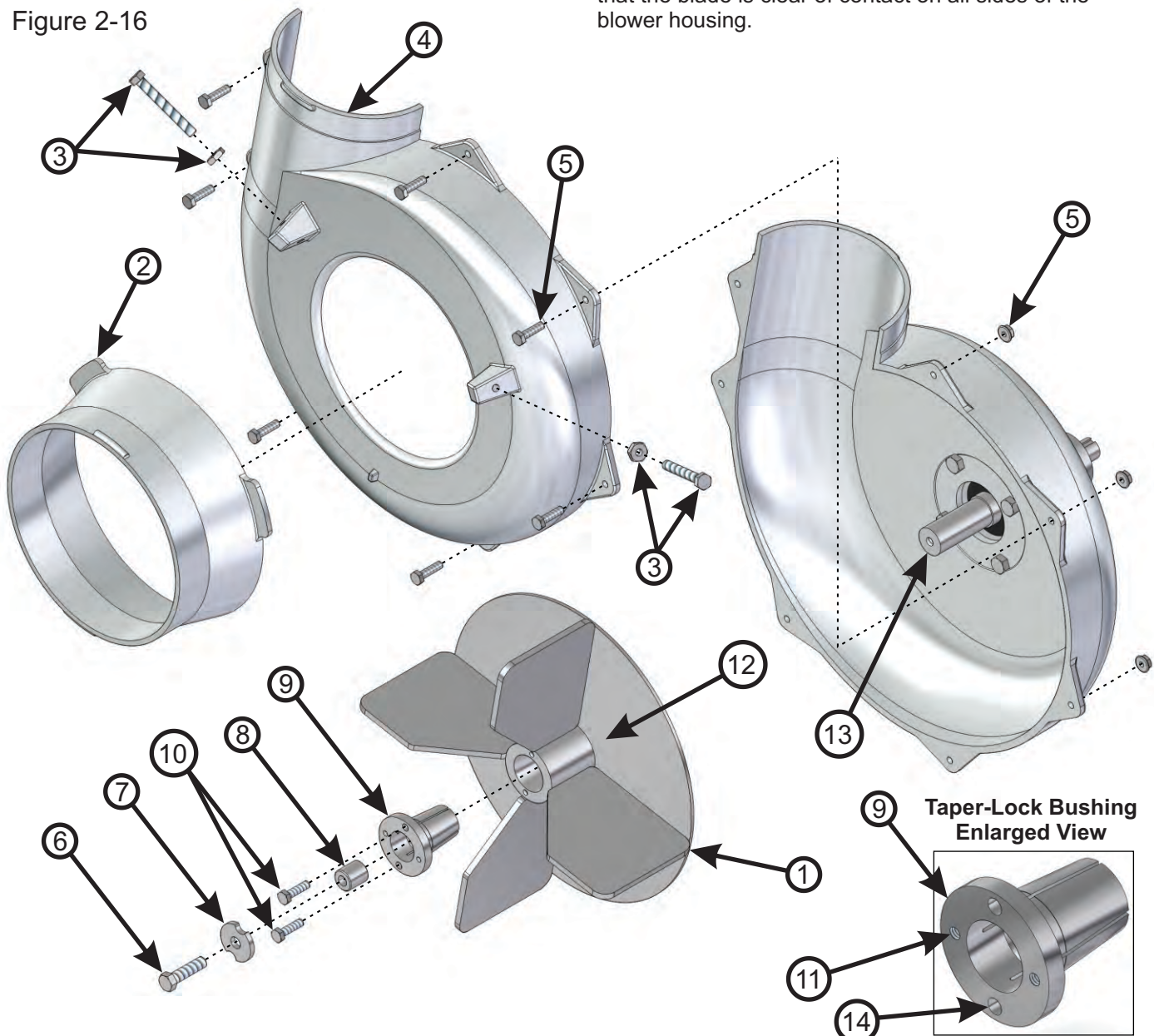

## 2-17 Weight Kit Installation

**NOTE:** It is recommended that someone assist you in the weight kit installation procedure.

Remove the front bumper and hardware from the mower frame. Attach the left weight bracket P#(B0383L) and right weight bracket P#(B0383R) to the front frame of the mower. Insert each weight bracket onto the frame tube. Secure each weight bracket using (2) 3/8"-16 x 3-1/2" HHCS P#(K1200), (1) 3/8" flat washers P#(K0047) and (2) 3/8"-16 nylon flange lock nuts P#(K2038). The (2) washers are used on the slotted holes on each weight bracket. Leave the hardware finger tight so the position of the weight brackets can be adjusted left or right if necessary.

Using two people, lift the weight bar P#(B2220) into position. Secure the weight bar to the left and right weight brackets using (2) 1/2"-13 x 4-1/4" u-bolts P#(K0331) and (4) 1/2"-13 nylon flange locknuts P#(K0212). Use Figure 2-17b for reference. **NOTE:** Before tightening the u-bolts, make sure the weight bar is centered between the weight brackets. Refer to Figure 2-17a for reference.

Replace the front bumper, adding (2) 1.187 x .380 x .187 flat washers P#(K1446) as spacers to allow clearance for the left and right weight bracket. Tighten all weight kit hardware at this time. Refer to Figure 2-17b for reference.

Figure 2-17a

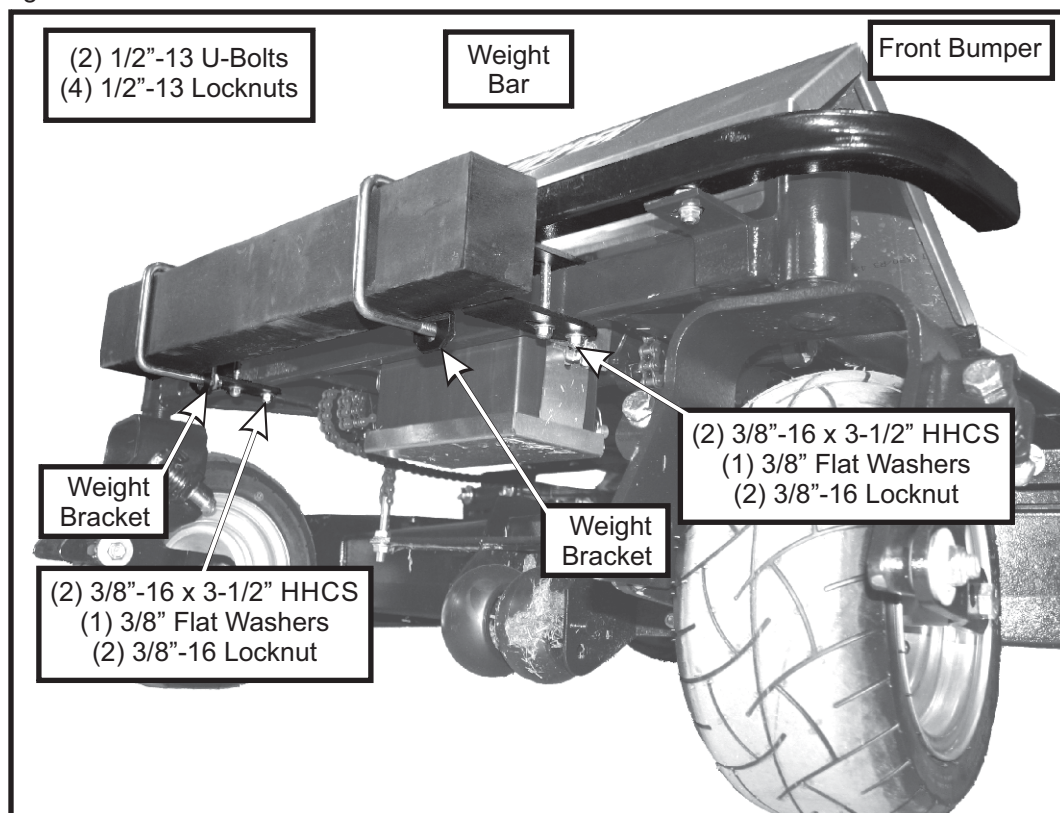
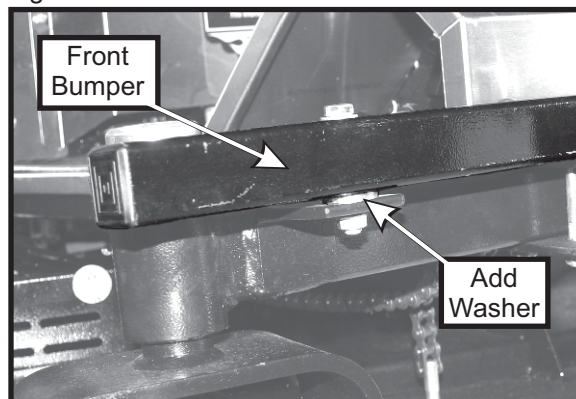

Figure 2-17b



## 2-18 Installation/Removal Of Collection Bags

### IMPORTANT!

To prevent bag wear, install (2) red plastic end caps P#(J0274), as shown in Figure 2-18a, on each bag ring before installing bags.

Figure 2-18a

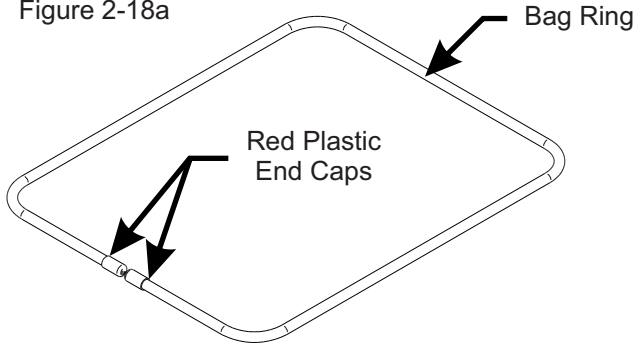

To install the bag onto the bag ring, place the seam openings of the bag onto the bag ring openings and turn the bag one full turn (360°) so the plastic end caps are located opposite to the opening in the bag (Figure 2-18b). Do this for each of three bags.

Figure 2-18b

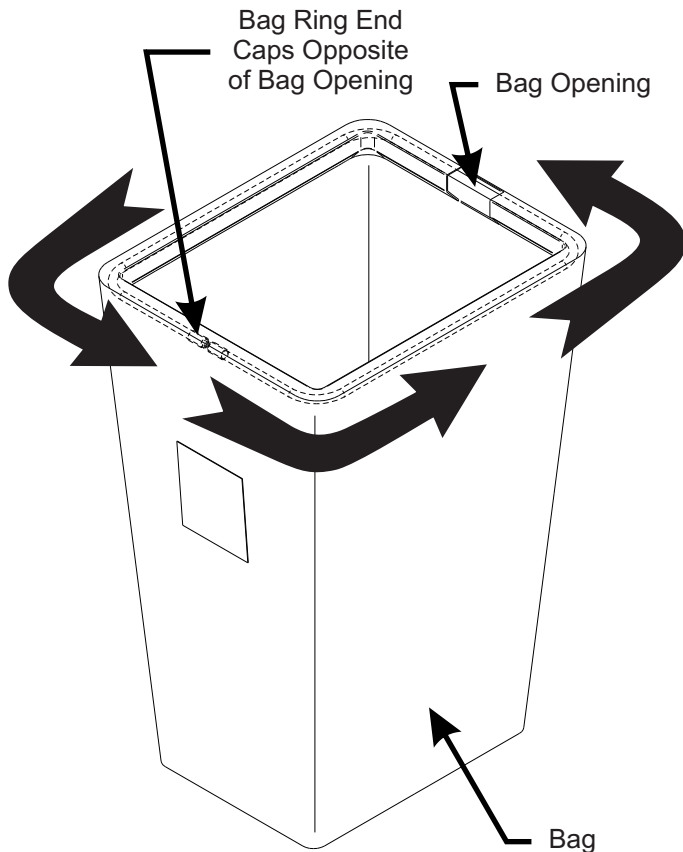

Install the completed assemblies onto the support frame and close the plastic top. Fasten both draw-latches to hold the plastic top closed (Figure 2-18c).

Figure 2-18c

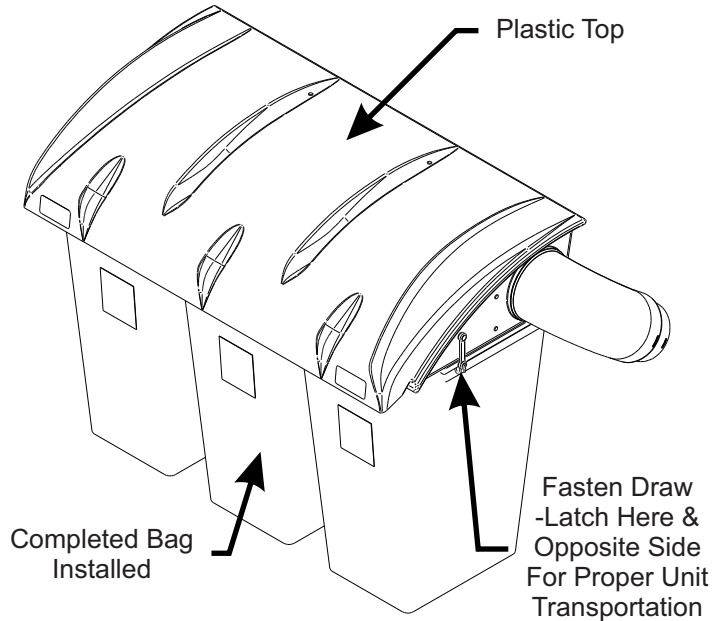

To empty the bag, first unlatch and lift top, next remove the bag and bag ring by sliding rearward, then grasp the loop on the bottom of the bag, and last turn it upside down to empty the collected debris (Figure 2-18d). Repeat for the other bags, line with plastic bags if desired, close the plastic top and reattach the draw latches.

Figure 2-18d

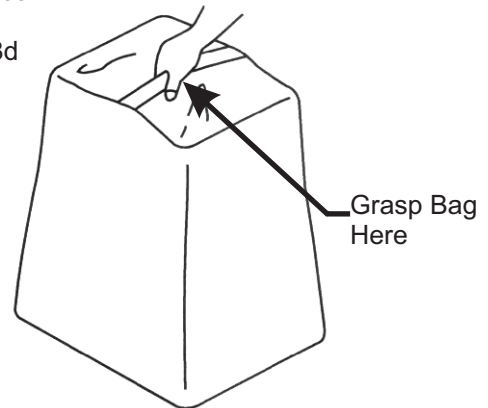

Plastic lawn and leaf bags, 33 gallon size, may be used inside the cloth bags. Be sure to leave enough plastic bag hanging over the frame so the plastic bags can be twist tied before emptying (Figure 2-18e).

Figure 2-18e

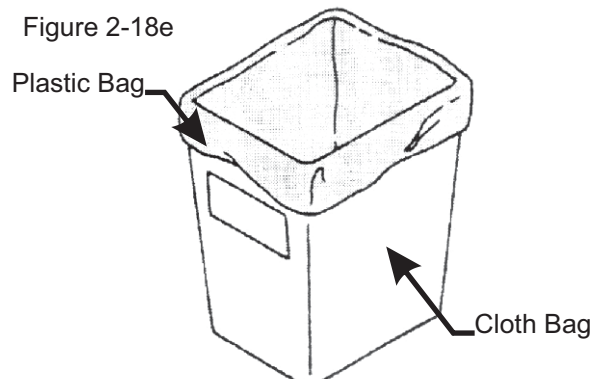

# Exploded Parts View

## A1187 Top Assembly

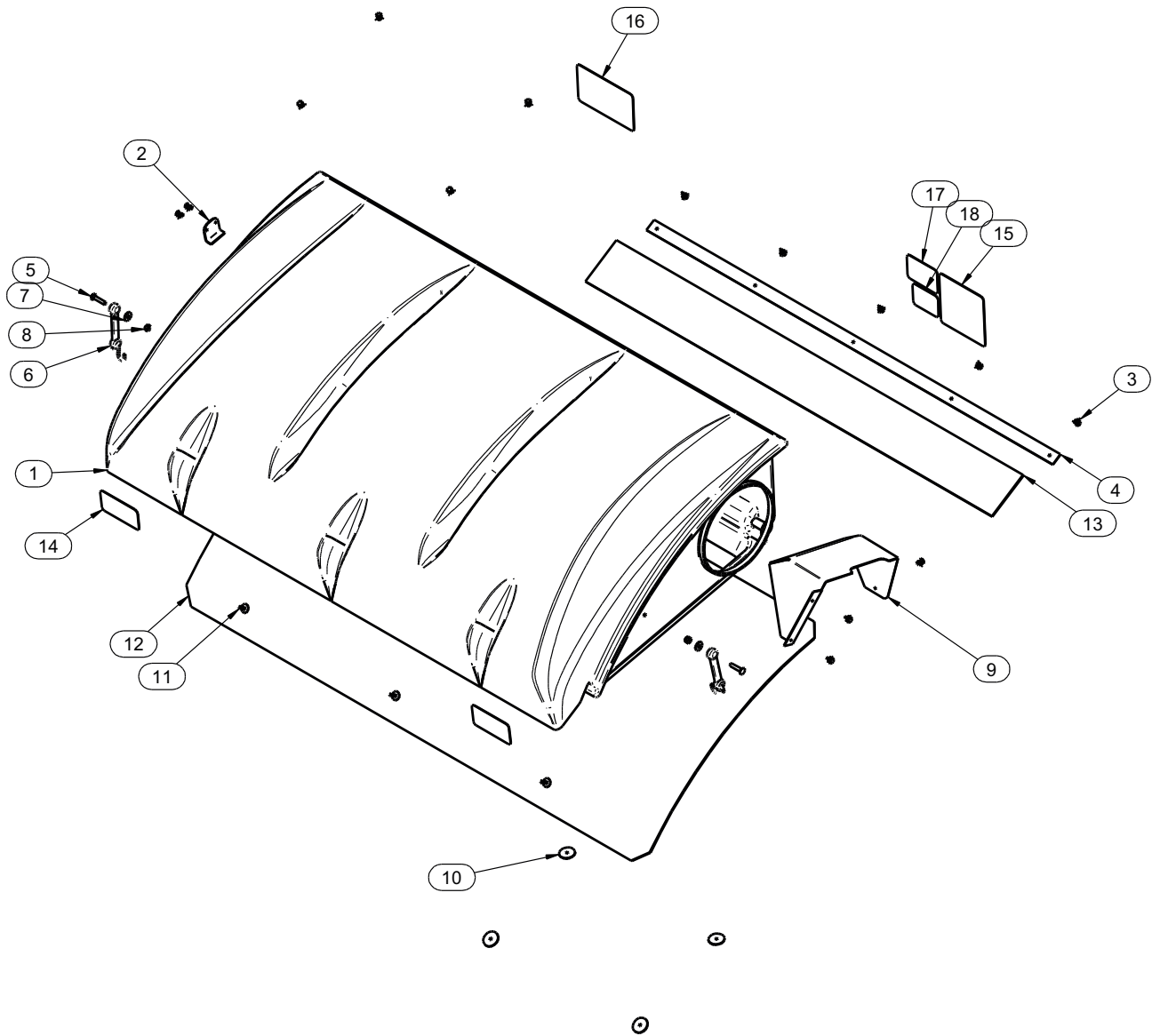

Item #	Doc #	Title	Qty
1	V0022	PRO 3 BAGGER TOP	1
2	B0676	Hinge Stop Pl.	1
3	K0114	BLACK PLASTIC RIVET	14
4	C0069	DUST GUARD BRACE	1
5	K1030	1/4"-20 x 1-1/4" CARRIAGE BOLT	2
6	J4009	SHORT RUBBER STRAP W/ S HOOK	2
7	K0037	1/4" FLAT WASHER .75 OD x .314 ID x .060 T	2
8	K1128	1/4"-20 NYLOC NUT	2
9	C0026	GRASS DEFLECTOR	1
10	K0062	3/16" x 1-1/2" FENDER WASHER, Z	4
11	K1265	BLACK PANEL RETAINER	3
12	V1120	Black Plastic Screen	1
13	V1118	DUST GUARD	1
14	R1057	2" x 4" Red Reflector Label	2
15	R1069	Warning - Turn Off Blower Label	1
16	R1065	Made In USA Label	1
17	R1054	Important Check Hoses	1
18	R1051	Warning - Use Hearing Protection	1

# **Exploded Parts View**

## **A1623 PTO Assembly**

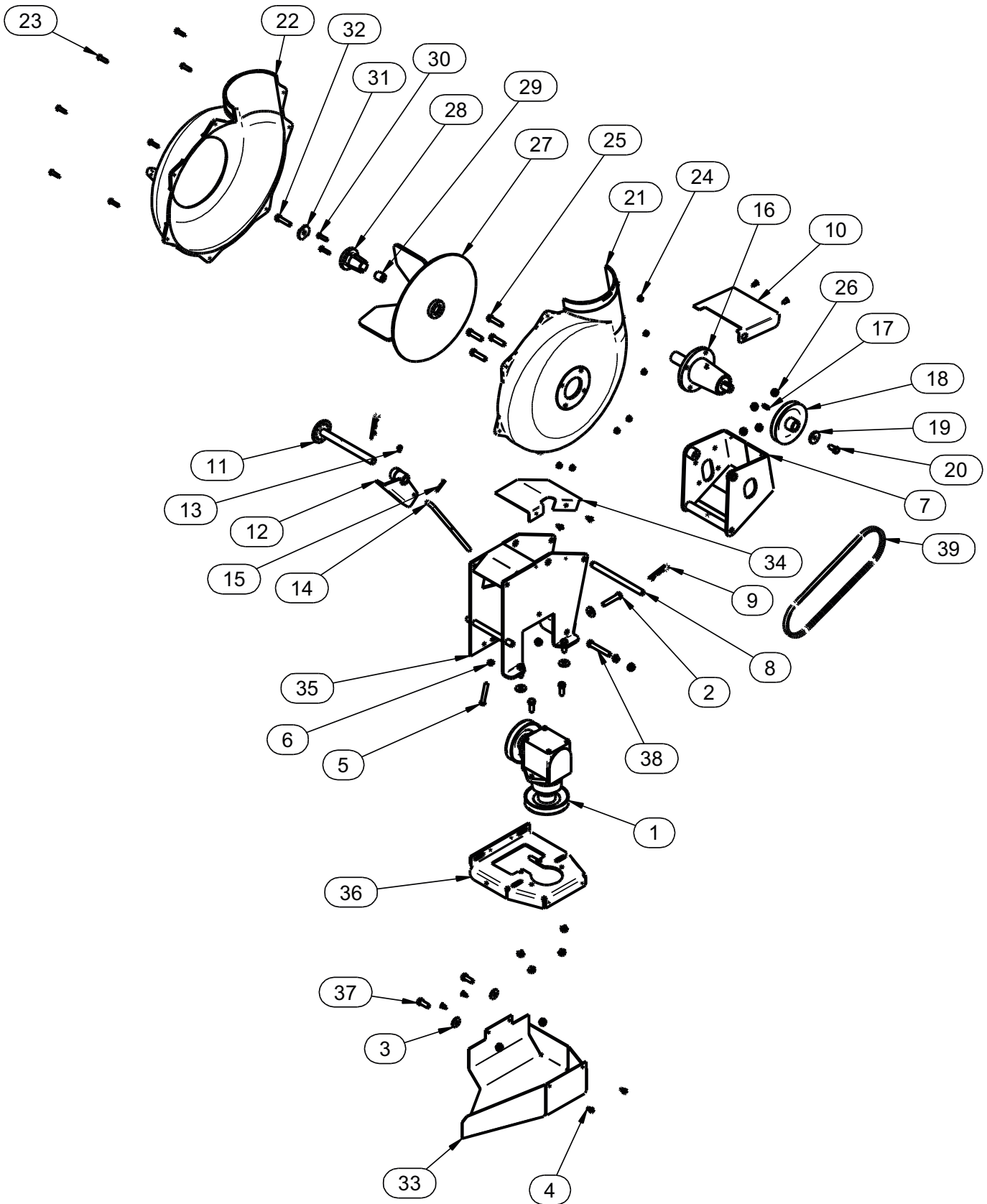

## **PTO Parts List**

### **A1623 PTO Assembly**

Item #	Part #	Desc.	Qty.
	A1623	PTO ASSEMBLY	
1	A0429	GEAR BOX ASSEMBLY	1
2	K0348	3/8"-16 x 2" ALL THREAD HHCS	1
3	K0047	3/8" Flat Washer 1.00 OD x .446 ID x .075 T	5
4	K0353	1/4"-20 x 1/2" HHSTS	8
5	K1159	5/16"-18 x 2" ALL THREAD HHCS	1
6	K1178	5/16"-18 FLANGE NUT	1
7	A0144	BLOWER MOUNT BRACKET ASSEMBLY	1
8	B1755	BLOWER PIVOT ROD	1
9	k0086	.125 OD x 2.50 HAIR PIN CLIP	2
10	b0121	BLOWER BELT GUARD	1
11	A0604	PTO HANDLE MOUNT ASSY	1
12	A0422	CAM BRACKET ASSEMBLY	1
13	K0356	3/8"-16 TAPERED SET SCREW	1
14	k0326	BELT TENSION ROD 3/8"-16	1
15	K0130	.091 OD x 1.625 L HAIR PIN CLIP	1
16	a0306	PTO SHAFT ASSEMBLY	1
17	J0254	3/16" x 3/16" x 3/4" Key	1
18	M0228	BLOWER PULLEY	1
19	K1446	1.187 OD x .380 ID x .187 WASHER	1
20	K1190	3/8"-16 x 3/4" HHCS	1
21	E4004B	BLOWER HSG. BACK	1
22	E4004F	BLOWER HSG. FRONT	1
23	K1125	1/4"-20 X 1" HHCS	7
24	K1126	1/4"-20 FLANGE NUT	7
25	K1193	3/8"-16 x 1-1/2" HHCS	4
26	K1215	3/8"-16 FLANGE NUT	12
27	A0645	SMALL 4-BLADE IMPELLER	1
28	S4302	TAPER-LOCK BUSHING	1
29	S3242	PLATED BUSHING	1
30	K1225	1/4"-20 X 1" HHCS GRADE 8	2
31	K0278	TAPER-LOCK BUSHING WASHER	1
32	K1211	3/8"-16 x 1-1/2" HHCS GRADE 8	1
33	B0679	Large Pulley Guard	1
34	B0270	PTO ARM GUARD	1
35	A1804	PTO ARM ASSY.	1
36	A0624	BASE PLATE ASSY.	1
37	K1191	3/8"-16 x 1" HHCS	6
38	K1197	3/8"-16 X 2 1/2" HHCS	1
39	M0250	A30K KEVLAR BELT	1

# DIXIE CHOPPER. XT3 COLLECTION SYSTEM

## Unit Model #: 38131504

Mower: Dixie Chopper	Owner's Manual: Q0459
Mower Type: Classic 2960, & 3360	Engine Type: KH 29HP & GEN 33HP
Deck Size: 60"	Vac Type: 15 Cubic Foot Pro 3 Bagger
Deck Type:	Drive Type: PTO Drive
Revision #: Final Release 4/1/13	Fits Year(s): 2011-2014

**A1880 Boot Kit**

**A1879 Weight Kit**

**A1899 Mount Kit**

**A1900 Vac Kit**

# DIXIE CHOPPER. XT3 COLLECTION SYSTEM

## Unit Model #: 38131503

Mower: Dixie Chopper	Owner's Manual: Q0459
Mower Type: Xcaliber 3366	Engine Type: Generac 33HP
Deck Size: 66"	Vac Type: 15 Cubic Foot Pro 3 Bagger
Deck Type:	Drive Type: PTO Drive
Revision #: Final Release 4/1/13	Fits Year(s): 2011-2014

**A1900 Vac Kit**

(1) A1187 Top Assy

(1) A1058 Upper Frame Assy

(3) B0227 Bag Ring

(3) G0003 4 Cu. Ft. Collection Bags

(2) J0060 Hose Clamps

(1) V0025 6" & 7" Plastic Inlet

R2007 LABEL

(1) HB0512 Vac Kit Hardware Bag

(1) A1872 Lwr. Frame Assy

(1) B0567 Lower Main Frame

(1) F0060 6" x 42" Upper Hose

**A1882 Mount Kit**

(1) F0080 8" x 36" Lower Hose

(1) HB0494 Mount Kit Hardware Bag

(2) J0080 Hose Clamps

(1) E6009 8" Blower Cone

(1) A1871 PTO Mt. PI. Assy.

(1) A1142 PTO Handle Assy.

(1) A1623 PTO Assy.

**A1883 Boot Kit**

(1) E0023 Boot

R4015 LABEL

R2007 LABEL

(1) HB0492 Hardware Bag

(1) B0333 Boot Rod

(1) B0783 Boot Plate

(1) B0776 Deck Plate

**A1879 Weight Kit**

(1) B2220 27" Weight Bar

(1) HB0488 Hardware Bag

(1) B0383R Rt. Weight Bracket

(1) B0383L Lt. Weight Bracket



# SECTION III OPERATING INSTRUCTIONS

## 3-1 General Safety

Only qualified people familiar with this operator's manual and the mower's operator's manual should operate this machine.

## 3-2 Operation And Tips On Mowing

- A. Perform BEFORE EACH USE the maintenance list in paragraph 4-1.
- B. Start mower.
- C. With the mower at high idle speed, engage the mower deck.
- D. While seated in the operator's seat, rotate the engagement handle of the collection system away from the mower. Continue to rotate the handle until it stops in an over center position. With the blower engaged, you can proceed to operate the control levers of the mower.

**NOTE:** If the collection system does not appear to be collecting the grass clippings, disengage the deck and blower, then, engage the parking brake and turn the mower off. Proceed to section 3-3, and review the section 2-4 in this manual.

To obtain the maximum effectiveness from your collection system the tips listed below should be followed:

- \* Watch your speed- Normal conditions will allow a speed of up to approximately 5 mph, but thick, heavy damp conditions will require reduced ground speed.
- \* Mow with sharp blades- A sharp blade cuts cleaner.
- \* Wet grass and leaves will decrease effectiveness and will increase horsepower requirements.
- \* Mow at higher cutting heights- Remove and mulch no more than 2" of grass length with each mowing. (Experts recommend not cutting off more than 1/3 of the grass blade length at any given time.)
- \* Mow twice, at different height settings, (high, then low), if grass is extra tall.
- \* Remember that horsepower requirements will vary with the mowing conditions such as type and height of turf grass, moisture content, amount of leaves, whether the terrain is flat or hilly, etc.

## 3-3 Disengagement Of The Blower

- A. To disengage the blower, rotate the engagement handle towards the mower.

**WARNING:** The blower will continue to spin. DO NOT TOUCH the blower, pulleys, or the belt until the tractor is turned off. DO NOT adjust the belt tension until the mower is turned off. Refer to section 2-4 of the manual.

## 3-4 Unloading The Collection System

**NOTE:** To determine when the collection bags are full, follow the following steps:

- A. Stop the forward movement of the mower.
- B. Disengage the mower deck.
- C. Disengage the blower.
- D. Engage the parking brake.
- E. Once the parking brake has been engaged, then and only then, walk behind the mower and check the collection bags by unlatching and lifting the top assembly. Load in bags should not exceed the height of the installed bag.
- F. To release bags, slide each bag out (towards operator) and turn bags over to deposit clippings.
- G. Return each bag to the original location, lower top assembly and re-latch to close .

**NOTE:** Do not allow collection bags to become over-filled as potential damage may occur to your equipment. Also, be sure to clean the hood screen as needed.

# SECTION IV MAINTENANCE

## 4-1 Maintenance Checklist

**NOTE: REMOVE PTO ASSEMBLY BEFORE RAISING DECK FOR MAINTENANCE.**

Before each use:

1. Check blades and spindles to be sure that no foreign objects, such as wire or steel strapping bands, are wrapped around them.
2. Inspect blades for wear. Replace if necessary. If it is necessary to sharpen the blades, remove the blades from the spindles before sharpening. DO NOT sharpen blades while still attached to the mower.

3. Make sure all shields are in place and in good condition. Repair or replace any missing or damaged shields.
4. Perform lubrication per paragraph 4-2.
5. Listen for abnormal sounds, which might indicate loose parts, damaged bearings, or other damage. Correct any deficiency before continuing operation.
6. With the engine off, engage the blower assembly. Check the belt tension and inspect the pulley belt for cracks or tears.
7. Check for wear or deterioration of the upper or lower hoses. If there are any portions of the hose that have been torn or worn through, replace with genuine PECO parts.

After Each Use:

1. Clean all debris from machine especially from the container, underneath the belt shields, and safety decals. Replace any missing or illegible decals.
2. Inspect the unit for worn or damaged components. Repair or replace before the next use. Any replacement component installed during repair shall include the component's current safety decal specified by the manufacturers to be affixed to the component.
3. Check belt for proper tension.

THE SERIAL NUMBER PLATE IS LOCATED ON THE TOP ASSEMBLY



WRITE THE MODEL AND SERIAL NUMBER IN THE BOX ABOVE FOR FUTURE REFERENCE.

## 4-2 Lubrication

**NOTE:** Use only white lithium based grease for lubrication of the shaft on the blower assembly.

1. On initial use: Grease the fitting on the blower shaft.
2. Every 25 hours of use: Re-grease the grease fitting.
3. Every 200 hours of use: Check oil levels in gear box. Oil in gear box should cover the gears. If necessary, fill using an EP90 weight oil. 6oz. will fill the gear box from empty.

# SECTION V PARTS AND SERVICE

## 5-1 Parts And Service Information

Collection system owners should record the name and telephone number of their Dixie Chopper dealer. Your Dixie Chopper dealer will be happy to supply replacement parts, accessories, and do any service or repairs to your collection system. If for any reason your Dixie Chopper dealer is unable to service your collection system or supply replacement parts, contact Dixie Chopper and include the following information on the chart below.

**Unit Model Number:** \_\_\_\_\_  
**Unit Engine Size:** \_\_\_\_\_  
**Unit Serial Number:** \_\_\_\_\_  
**Date of purchase:** \_\_\_\_/\_\_\_\_/\_\_\_\_  
**Dealer/Distributor Name:** \_\_\_\_\_  
**Address:** \_\_\_\_\_ **State:** \_\_\_\_\_ **Zip:** \_\_\_\_\_  
**Phone Number:** \_\_\_\_\_

# SAFETY DECALS

To promote safe operation, Dixie Chopper supplies safety decals on all products manufactured. Damage can occur to safety decals either through shipment, use or reconditioning. Contact your local Service Center for replacement decals.



Part #: R4015  
Danger: Rotating Blades Label



Part #: R0012  
Lrg XT3 Label



Part #: R1051  
Warning: Hearing Protection Label



Part #: R1069  
Warning: Turn Off Blower Label



Part #: R0013  
Sml XT3 Label



Part #: R1054  
Important: Check Hoses Label

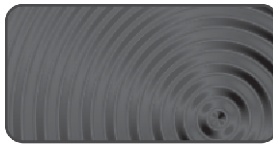

Part #: R1057  
Red Reflector Label

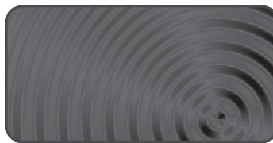

Part #: R4008  
Caution: Rotating Blades Label



Part #: R1065  
Made In America Label



Part #: R4037  
Warning: Hot Surface Label



Part #: R2007  
Danger: Never Use Hands Label

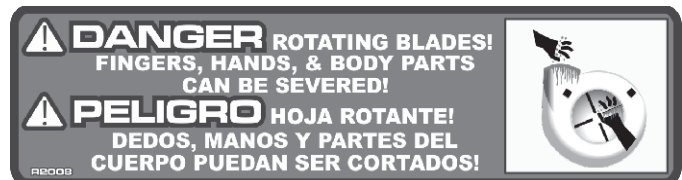

Part #: R2008  
Danger: Rotating Blades Label

# TORQUE SPECIFICATIONS

## AMERICAN Bolt Head Markings

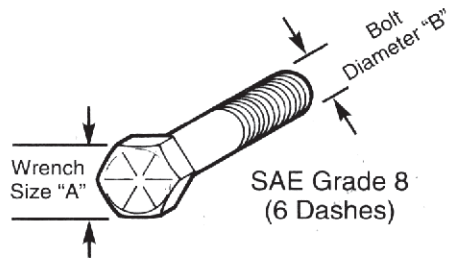

Recommended Torque in Foot Pounds (Newton Meters).\*

WRENCH SIZE (IN.) "A"	BOLT DIAMETER (IN.) "B" AND THREAD SIZE	SAE GRADE 2	SAE GRADE 5	SAE GRADE 8
7/16	1/4 - 20 UNC	6 (7)	8 (11)	12 (16)
7/16	1/4 - 28 UNF	6 (8)	10 (13)	14 (18)
1/2	5/16 - 18 UNC	11 (15)	17 (23)	25 (33)
1/2	5/16 - 24 UNF	13 (17)	19 (26)	27 (37)
9/16	3/8 - 16 UNC	20 (27)	31 (42)	44 (60)
9/16	3/8 - 24 UNF	23 (31)	35 (47)	49 (66)
5/8	7/16 - 14 UNC	32 (43)	49 (66)	70 (95)
5/8	7/16 - 20 UNF	36 (49)	55 (75)	78 (106)
3/4	1/2 - 13 UNC	49 (66)	76 (103)	106 (144)
3/4	1/2 - 20 UNF	55 (75)	85 (115)	120 (163)
7/8	9/16 - 12 UNC	70 (95)	109 (148)	153 (207)
7/8	9/16 - 18 UNF	79 (107)	122 (165)	172 (233)
15/16	5/8 - 11 UNC	97 (131)	150 (203)	212 (287)
15/16	5/8 - 18 UNF	110 (149)	170 (230)	240 (325)
1-1/8	3/4 - 10 UNC	144 (195)	266 (360)	376 (509)
1-1/8	3/4 - 16 UNF	192 (260)	297 (402)	420 (569)
1-5/16	7/8 - 9 UNC	166 (225)	430 (583)	606 (821)
1-5/16	7/8 - 14 UNF	184 (249)	474 (642)	668 (905)
1-1/2	1 - 8 UNC	250 (339)	644 (873)	909 (1232)
1-1/2	1 - 12 UNF	274 (371)	705 (955)	995 (1348)
1-1/2	1 - 14 UNF	280 (379)	721 (977)	1019 (1381)
1-11/16	1-1/8 - 7 UNC	354 (480)	795 (1077)	1288(1745)
1-11/16	1-1/8 - 12 UNF	397 (538)	890 (1206)	1444 (1957)
1-7/8	1-1/4 - 7 UNC	500 (678)	1120 (1518)	1817 (2462)
1-7/8	1-1/4 - 12 UNF	553 (749)	1241 (1682)	2013 (2728)
2-1/16	1-3/8 - 6 UNC	655 (887)	1470 (1992)	2382 (3228)
2-1/16	1-3/8 - 12 UNF	746 (1011)	1672 (2266)	2712 (3675)
2-1/4	1-1/2 - 6 UNC	870 (1179)	1950 (2642)	3161 (4283)
2-1/4	1-1/2 - 12 UNF	979 (1327)	2194 (2973)	3557 (4820)

## METRIC

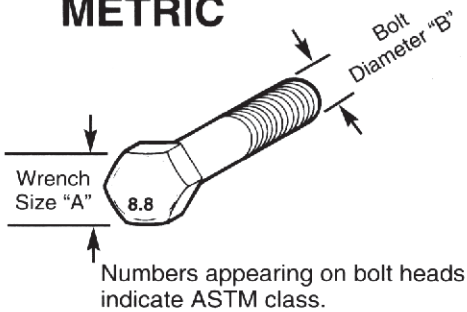

Recommended torque in foot pounds (newton Meters).\*

WRENCH SIZE (mm) "A"	BOLT DIA. (mm) "B"	ASTM 4.6	ASTM 8.8	ASTM 9.8	ASTM 10.9
8	5	1.8 (2.4)		5.1 (6.9)	6.5 (8.8)
10	6	3 (4)		8.7 (12)	11.1 (15)
13	8	7.3 (10)		21.1 (29)	27 (37)
16	10	14.5 (20)		42 (57)	53 (72)
18	12	25 (34)	74 (100)	73 (99)	93 (126)
21	14	40 (54)	118 (160)	116 (157)	148 (201)
24	16	62 (84)	167 (226)	181 (245)	230 (312)
30	20	122 (165)	325 (440)		449 (608)
33	22		443 (600)		611 (828)
36	24	211 (286)	563 (763)		778 (1054)
41	27		821 (1112)		1138 (1542)
46	30	418 (566)	1119 (1516)		1547 (2096)

\*Use 75% of the specified torque value for plated fasteners. Use 85% of the specified torque values for lubricated fasteners.



**Contact: [service@dixiechopper.com](mailto:service@dixiechopper.com)  
765-246-6191 FAX 765-246-6017**