



PTO GRASS COLLECTION SYSTEM

DESIGNED TO FIT:

SCAG

**2012 MODEL YEAR
TIGER CAT**

**52" & 61" VELOCITY
PLUS DECK**



**MODEL #: 37131504
PTO DRIVE**

**MODEL #: 37131505
900 SERIES BRIGGS & STRATTON**

**MODEL #: 37131506
6.5HP BRIGGS & STRATTON
VANGUARD**

OPERATOR'S MANUAL

ASSEMBLY • OPERATION • MAINTENANCE

MANUAL PART#: G0431

PECO GRASS COLLECTION SYSTEM

TABLE OF CONTENTS

SECTION	PAGE	SECTION	PAGE
Safety	2	2-17 Inlet Installation	11
Safety Alert Symbols	3	2-18 Boot To Mower Deck Installation	11
Warranty	4	2-19 Length Of Hose Adjustment	12
I INTRODUCTION AND DESCRIPTION	5	2-20 Upper Hose Installation	12
1-1 Introduction	5	2-21 Lower Hose To Blower Cone Installation	12
1-2 Description	5	2-22 Lower Hose To Boot Installation	12
II INSTALLATION FOR USE	6	2-23 Impeller Blade Removal/Replacement	13
2-1 Preparation Of Mower	6	2-24 Weight Kit Installation	14
2-2 Lower Mount Plate Installation	6	2-25 Installation/Removal of Collection Bags	15
2-3 Lower Mount Tube Installation	7	2-26 Throttle Cable Installation	16
2-4 Upper Frame Assembly Installation	7	Exploded Part Views and Assemblies	17-22
2-5 Top Assembly To Upper Frame Assembly Installation	7	III OPERATING INSTRUCTIONS	23
2-6 Hinge Kit Assembly Installation	7	3-1 General Safety	23
2-7 Exhaust Diverter Installation	8	3-2 Operation & Tips On Mowing	23
2-8 PTO Mount Plate Assembly Installation	8	3-3 Disengagement Of The Blower	23
2-9 PTO Assembly Installation	8	3-4 Unloading The Collection System	23
2-10 Belt Installation and Adjustment	9	IV MAINTENANCE	23
2-11 PTO Handle Assembly Installation	10	4-1 Maintenance Checklist	23-24
2-12 Cam Assembly Adjustment	10	4-2 Lubrication	24
2-13 Outer Engine Mount Tube Installation	10	V PARTS AND SERVICE	24
2-14 Engine Mount Arm Assembly Installation	10	5-1 Parts And Service Information	24
2-15 Engine/Blower/Blade Assembly Installation	11	Safety Decals	25
2-16 Blower Cone Installation	11	Torque Specifications	26

Safety

1. Read the operator's manual carefully and familiarize yourself with the proper use of your attachment. Do not allow anyone who is not acquainted with the Safety Instructions to use your attachment.
2. Know the controls and how to stop quickly. **READ THE OPERATOR'S MANUAL!**
3. Do not allow children to operate the vehicle. Do not allow adults to operate it without proper instruction.
4. Be especially watchful of children and pets darting into the area while operating.
5. Keep your eyes and mind on your unit while mowing or operating your attachment. Don't let others distract you.
6. Do not attempt to operate your unit or mower when not in the driver's seat.
7. Always stop unit when emptying the container.
8. Stop unit, shut off deck attachment, set parking brake, shut off mower engine and remove spark plug wire before removing clogs, removing or replacing hose, boot, blower cone, or performing any maintenance.
9. Mow across the face of slopes (not steeper than 10 degrees); never up and down the face of the slope.
10. It is recommended that the container be kept only half full when negotiating any slopes. Start mowing on slopes when the container is empty.
11. Inspect your lawn and remove any foreign objects before mowing. Never deliberately run the mower across any foreign object.
12. Wear ear protection if the noise level is offensive.
13. Wear eye protection to prevent debris from damaging your eyes.

SAFETY

WARNING! **NEVER** operate the mower unless the discharge guard and either the deflector assembly or the vacuum collector adapter are fastened securely in place.

WARNING! Do not work around the mower deck boot or the blower area until you are certain that the mower blades and the blower impeller have stopped rotating.

WARNING! To avoid serious injury, perform maintenance on the vacuum collector; **ONLY AFTER STOPPING THE MOWER'S ENGINE AND WAITING FOR ALL MOVING PARTS TO COME TO A COMPLETE STOP.** Set the parking brake. Always remove the ignition key before beginning maintenance.

WARNING! For your own personal safety, **ALWAYS** mow **ACROSS** the face of slopes and **NEVER UP and DOWN** the face. **NEVER** attempt to mow excessively steep slopes, and use caution when turning on any slope.

Safety Alert Symbol



This Safety Alert Symbol means: **“ATTENTION! BECOME ALERT! YOUR SAFETY IS INVOLVED!”**

This symbol is used to call attention to safety precautions that should be followed by the operator to avoid accidents. When you see this symbol, carefully read the message that follows and heed its advice. Failure to comply with safety precautions could result in death or serious bodily injury.

Safety Signs

The signal words **DANGER**, **WARNING**, and **CAUTION** are used on the equipment safety signs. These words are intended to alert the viewer to the existence and the degree of hazard seriousness.



White letters on **RED**

This signal word indicates a potentially hazardous situation which, if not avoided, will result in death or serious injury.



Black letters on **ORANGE**

This signal word indicates a potentially hazardous situation which, if not avoided, could result in death or serious injury.

It may also be used to alert against unsafe practices.



Black letters on **YELLOW**

This signal word indicates a potentially hazardous situation exist which, if not avoided, will result in minor or moderate injury.

It may also be used to alert against unsafe practices.

PECO LIMITED WARRANTY FOR NEW PRODUCTS

A. WHAT IS UNDER WARRANTY?

PECO extends the following warranties to the original purchaser of each new PECO consumer product subject to the following limitations.

1. PRODUCT WARRANTY: Any part of any consumer product, which is defective in material or workmanship as delivered to the purchaser will be repaired or replaced, as PECO elects, without charge for parts or labor, if the defect appears within 12 months from the date of delivery of the product to the original purchaser. **ALL DEFECTIVE PARTS MUST BE RETURNED TO PECO FOR INSPECTION TO DETERMINE VALIDITY OF WARRANTY CLAIMS.** Freight and mailing will be borne by the customer.

2. PARTS REPLACED DURING WARRANTY: Any new PECO part which is furnished in performance of this warranty and is defective in material or workmanship as delivered to the purchaser will be repaired or replaced, as PECO elects, without charge if the defect appears within 90 days from the date of installation of such part or before the expiration of the original warranty period, whichever is later.

B. SECURING WARRANTY ADJUSTMENTS.

Call PECO for Return Authorization. Damaged or broken parts other than engines or batteries, must be returned to New PECO, Inc. 100 Airport Road, Arden, NC 28704 before any warranty adjustment can be authorized. At the time of requesting warranty adjustment, the purchaser must present evidence of the date of delivery of the product. The purchaser shall pay any charge for the product to and from Arden, NC.

C. ITEMS NOT COVERED BY PECO WARRANTY.

Engines and batteries attached to PECO products are covered under a separate warranty by the respective manufacturer.

D. UNAPPROVED ALTERATION OR MODIFICATION.

All obligations of New PECO, Inc. under this warranty shall be terminated if products are altered or modified in ways not approved by New PECO, Inc.

E. ACCIDENTS AND NORMAL MAINTENANCE.

The warranty covers only defective material and workmanship. It does not cover depreciation or damage caused by normal wear, accident, improper use or abuse of products. The cost of normal maintenance and normal replacement of service items such as belts, cutting blades, hoses, etc., which are not defective shall be paid for by the purchaser.

F. NO REPRESENTATIONS ADDITIONAL WARRANTIES, DISCLAIMER.

Neither New PECO, Inc. nor any company affiliated with it makes any warranties, representations or promises as to the quality of performance of its products other than those set forth herein. Except as described above, New PECO, Inc. makes no other warranties **AND SPECIFICALLY DISCLAIMS ANY AND ALL IMPLIED WARRANTIES OF FITNESS AND MERCHANTABILITY.**

G. ANY MACHINE USED FOR RENTAL PURPOSES ARE GUARANTEED FOR 45 DAYS FROM DATE OF ORIGINAL SALE ONLY.

H. REMEDIED EXCLUSIVE.

The only remedies the purchaser has in connection with the breach or performance of any warranty on New PECO, Inc. consumer products are set forth above. In no event will PECO be liable for special incidental or consequential damages.

1. NO SERVICE CENTER WARRANTY.

The selling Service Center makes no warranty on his own on any item warranted by New PECO, Inc. unless he delivers to purchaser a separate written warranty certificate specifically warranting the item. The dealer has no authority to make any representation or promise on behalf of PECO or to modify the terms of this warranty in any way.

Section I - INTRODUCTION AND DESCRIPTION

1-1 Introduction

We are pleased to have you as a PECO customer. Your collection system has been designed to give you a low maintenance, simple, and effective way to collect the grass clippings from your mower. This manual is provided to give you the necessary instructions to properly mount and operate the collection system on your mower. Please read this manual thoroughly. Understand what each control is for and how to use it. Observe all safety decal precautions on the machine and noted throughout the manual.

NOTE: all references made to right, left, front, rear, top or bottom are as viewed from the normal operator's position on the mower.

1-2 Description

The grass collection system is designed for turf maintenance where there is a need to collect the grass clippings as the mower cuts the turf. It is also used for picking up leaves and in pre-season and post-season clean-up. The blower, mounted on the right side of the unit, uses a belt and gearbox system from the engine PTO shaft. Drive train protection comes through belt slippage. The blower is also available with an external engine option of 5.5HP or 6.5HP. The blower draws grass clippings from the discharge area of the cutter deck back to the (3) - 4 cubic foot collection bags P#(G0003) at the rear portion of the mower frame. The operator can engage the blower with a push of the over-center linkage on the right side of the unit. Once the bags are full with clippings, they can be released to make for easy dumping.

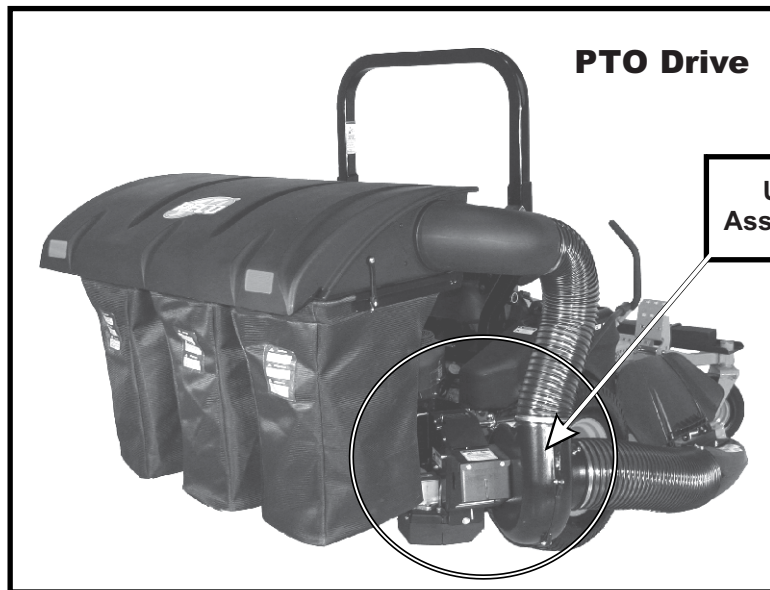

Universal PTO
Assembly P#(A0623)

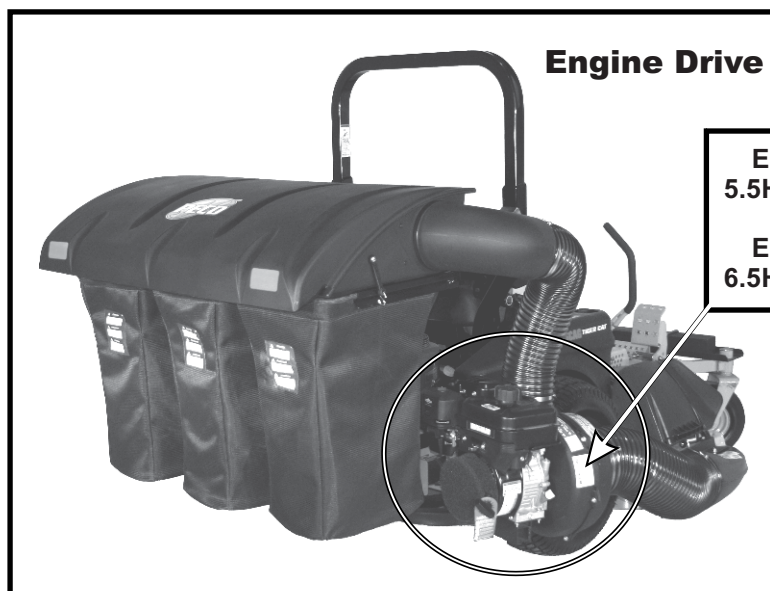

Engine/Blower/Blade Assembly
5.5HP Briggs and Stratton P#(A602)
or
Engine/Blower/Blade Assembly
6.5HP Briggs and Stratton P#(A639)

Section II - INSTALLATION FOR USE

2-1 Preparation Of Mower

Remove the rear shield and skid plate from the mower. Remove (3) 3/8" carriage bolts and (3) 3/8"-16 nuts from the rear bumper to disconnect the rear shield. Remove (2) 3/8"-16 carriage bolts (2) 3/8"-16 nuts from the skid plate to disconnect the skid plate from the frame of the mower. Refer to Figure 2-1a for reference. Keep the hardware for use later in the installation.

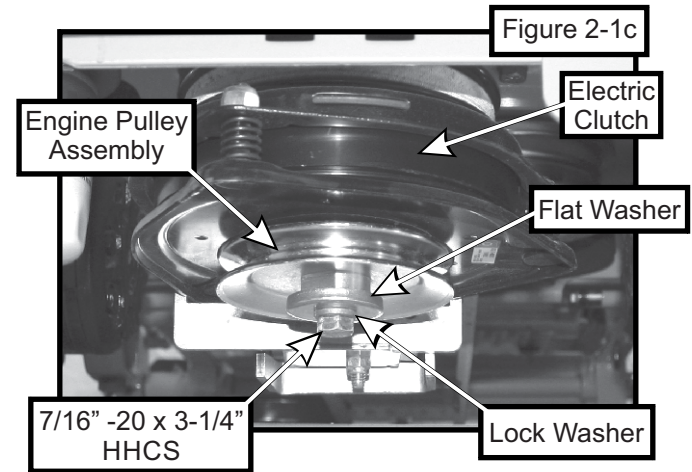
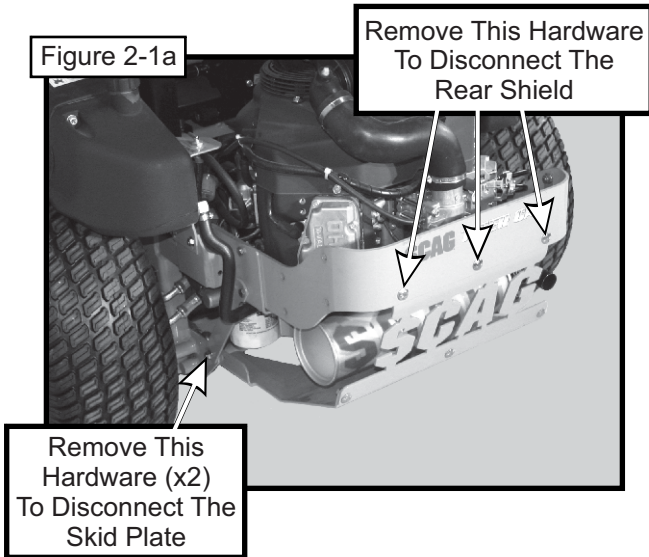

2-2 Lower Mount Plate Installation

Attach the lower mount plate P#(B0719) to the rear of the mower. Use the existing hardware removed in Section 2-1a. The lower mount plate attaches to the rear bumper with (3) existing carriage bolts and nuts. The lower mount plate attaches to the rear frame, where the skid plate was removed, using (2) existing carriage bolts and nuts. Refer to Figure 2-2.

NOTE: Engine pulley installation instructions are for PTO models only.

From the underside of the mower, remove the 7/16" bolt, lock washer and flat washer that secure the electric clutch to the engine shaft. Refer to Figure 2-1b.

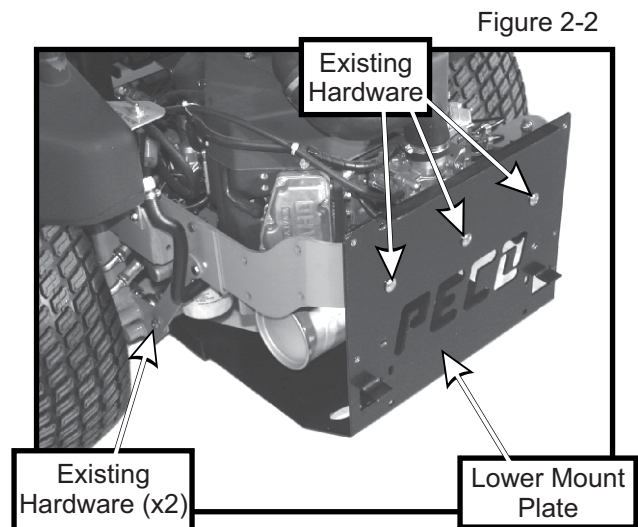
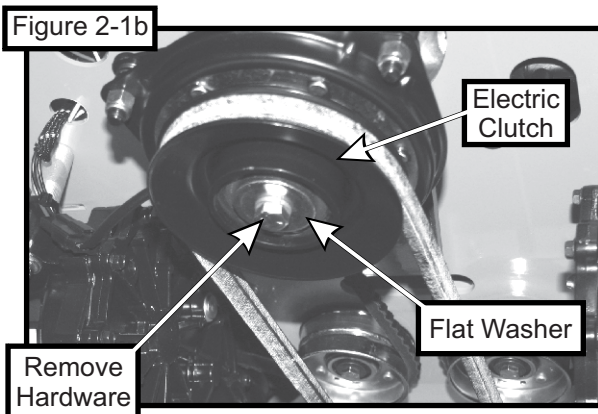

Locate the engine pulley hardware bag P#(HB0473). Secure the engine pulley assembly number 13 P#(A0732) to the electric clutch using (1) 7/16"-20 x 3-1/4" HHCS P#(K0351), (1) helical spring lock washer P#(K0140), (1) .250 x .250 x .500 keyway P#(K1628) and the flat washer removed in Section 2-1b. Refer to Figure 2-1c for reference.

2-3 Lower Mount Tube Installation

Secure (2) lower mount tubes P#(B0726) to the lower mount plate using (2) 5/16"-18 x 2" x 2-1/4" u-bolts P#(K1098) and (4) 5/16"-18 nylon flange locknuts P#(K2516) **PER TUBE**. The lower mount tubes should rest flush onto the two tabs in the lower mount plate. Refer to Figure 2-3.

Figure 2-3

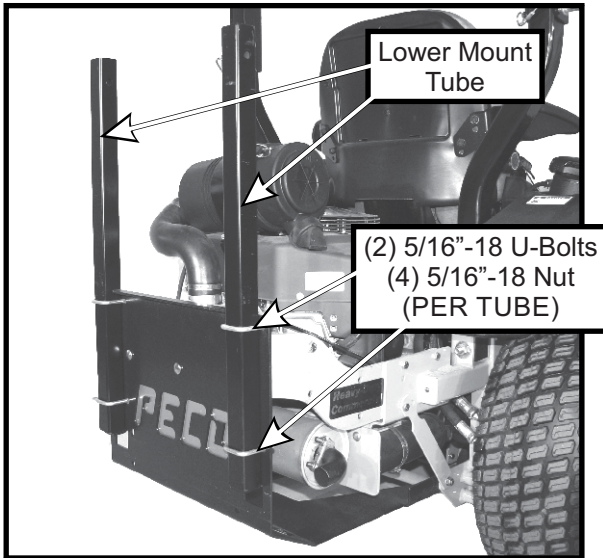

2-4 Upper Frame Assembly Installation

Lift the upper frame assembly P#(A1058) above the lower mount tubes, as shown in Figure 2-4. Slide the upper frame assembly down onto the (2) lower mount tubes. Secure the upper frame assembly using (2) clevis pins P#(K0133) and (2) hair pin clips P#(K0088).

Figure 2-4

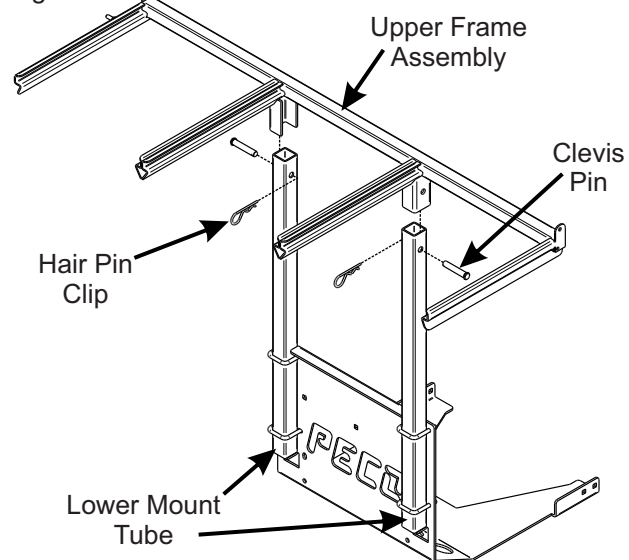

2-5 Top Assembly To Upper Frame Assembly Installation

Position the top assembly P#(A1157) above the upper frame assembly as shown in Figure 2-5. Fasten the top assembly to the upper frame assembly using (2) 5/16"-18 x 2-1/2" HHCS P#(K0125) and (2) 5/16"-18 nylon flange locknuts P#(K2516). Leave the locknuts slightly loose, to allow the top assembly to open and close easily. Refer to Figure 2-5 for hardware location.

Figure 2-5

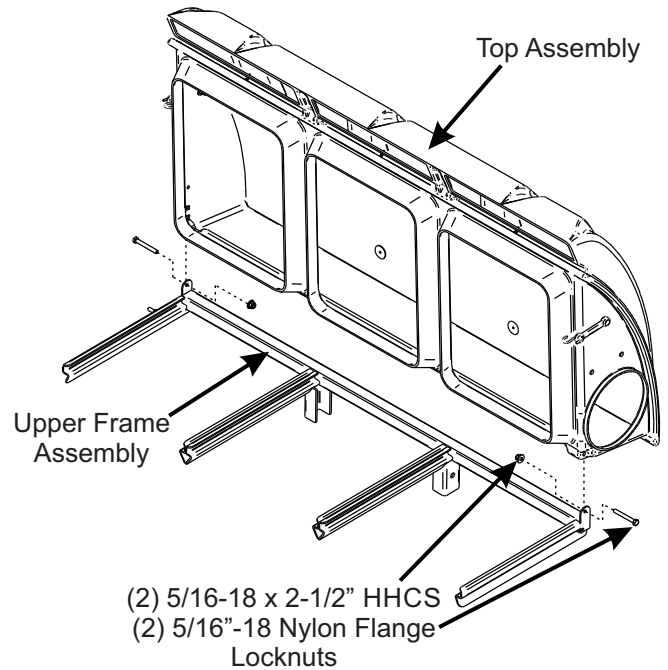

2-6 Hinge Kit Assembly Installation

Assemble the hinge kit as shown in Figure 2-6, using (2) 5/16"-18 x 1" HHCS P#(K1154), (3) 5/16"-18 nylon flange locknuts P#(K2516), (5) 1/4" flat washers P#(K0037) and (2) swing arm brackets P#(ZT-0004). Place (1) vinyl cap P#(J0289) on the end of the hex bolts as shown in Figure 2-6. Leave the nuts loose enough to allow fluid movement of the top when opening and closing. When opened, the top should rest on the middle joint of the hinge allowing it to remain up.

Figure 2-6

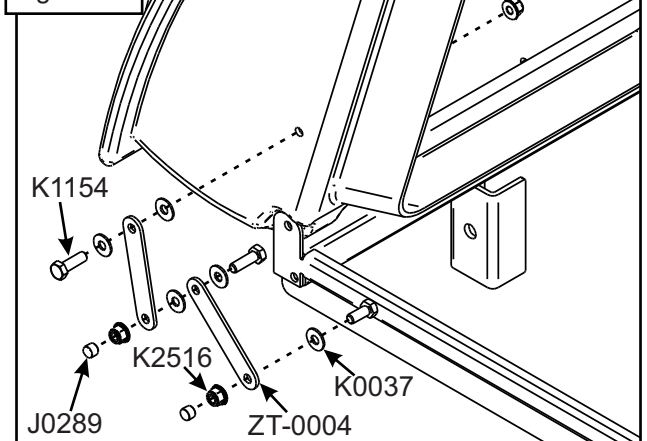

2-7 Exhaust Diverter Installation

Insert the exhaust deflector P#(J0251) onto the end of the muffler. Orientate the exhaust diverter to exhaust towards the rear of the mower. The diverter is used to keep the engine exhaust from burning the cloth bags, and the PTO or engine/blower/blade assembly. Secure the exhaust diverter with (1) exhaust clamp kit P#(X1046). Refer to Figure 2-7.

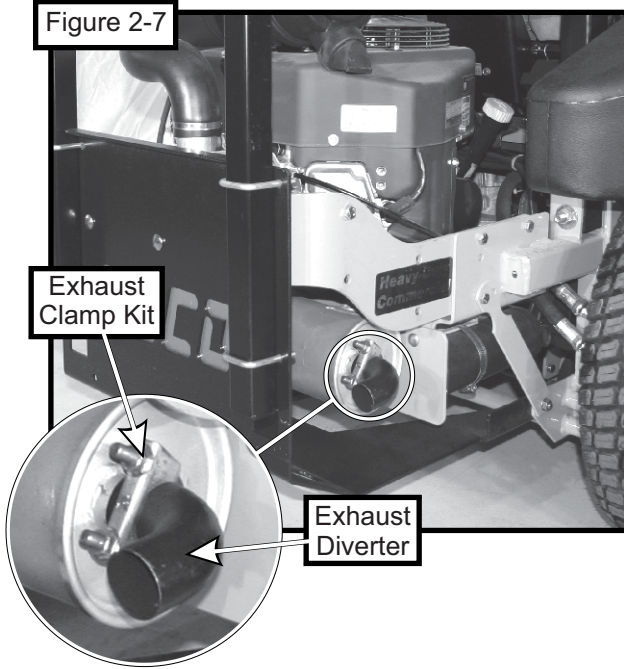

2-8 PTO Mount Assembly Installation PTO MODELS ONLY

NOTE: Continue to Section 2-13 on page 10 if you are installing an engine driven unit.

Secure the PTO mount plate assembly P#(A1825) to the rear bumper of the mower using (4) 3/8"-16 x 1" HHCS P#(K1191) and (4) 3/8"-16 nylon flange locknuts P#(K2038). Refer to Figure 2-8a.

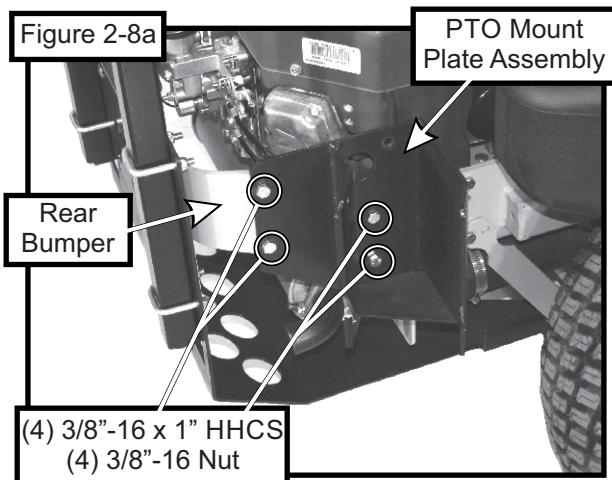

On all engine models with an engine oil drain hose on the right side of the engine, attach the existing J-hook to the rear bumper using the PTO mount assembly hardware shown in Figure 2-8b.

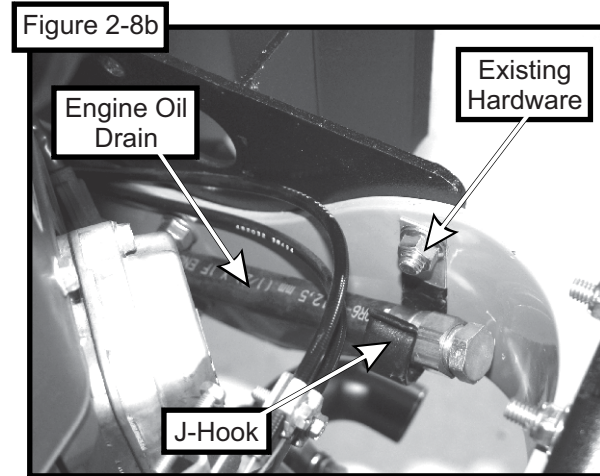

2-9 PTO Assembly Installation PTO MODELS ONLY

Insert the PTO assembly P#(A0623) into the PTO mount plate assembly as shown in Figure 2-9a. The mount rod on the PTO assembly slides into the mounting slots on the PTO mount plate assembly. Secure the PTO assembly with (1) mount pin P#(B0274) and (1) hair pin clip P#(K0086) shown in Figure 2-9b. Remove the pulley guard in preparation for the belt installation.

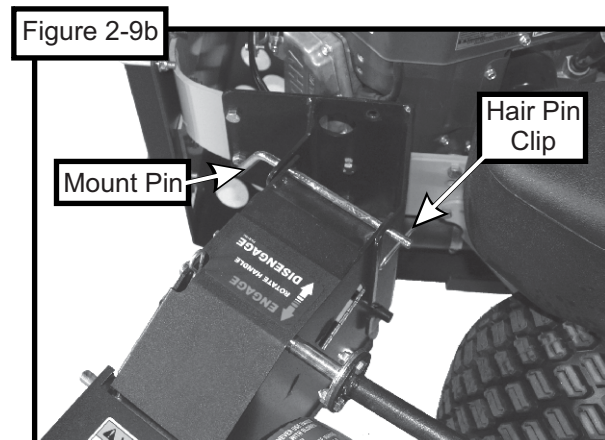
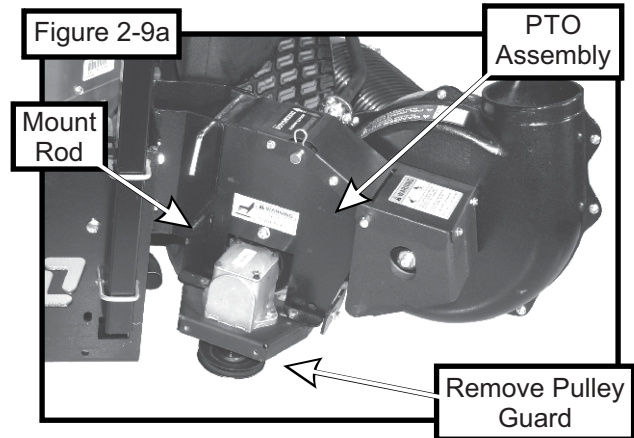

2-10 Belt Installation and Adjustment PTO MODELS ONLY

Loosen the (4) bolts P#(K1191), (2) on each side, that secure the gear box assembly to the PTO assembly P#(A0623) (Figure 2-10a and 2-10b).

Figure 2-10a

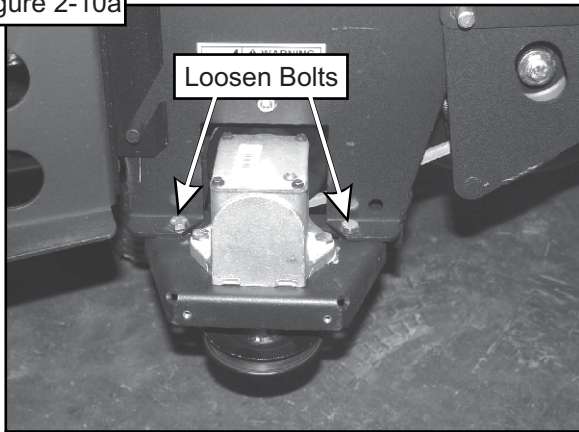
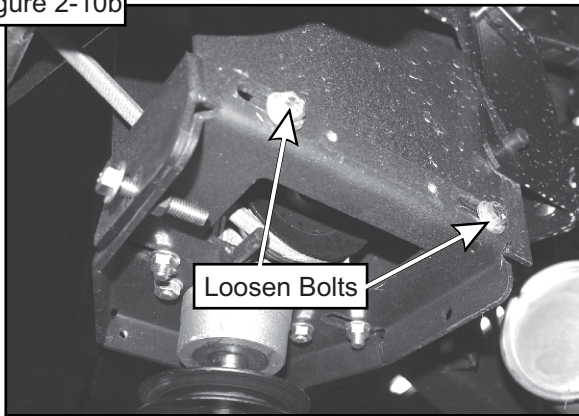
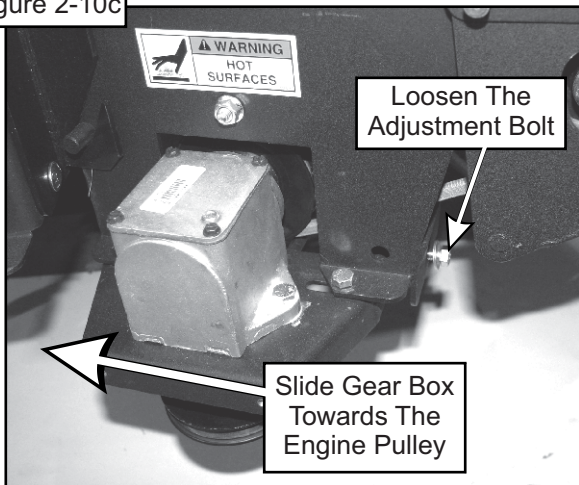

Figure 2-10b



Loosen the adjustment bolt P#(K0348) until the gear box assembly is at its far left adjustment (the gear box is moved toward the mower's engine pulley). Refer to Figure 2-10c.

Figure 2-10c



Connect the belt A58K P#(M0236) from the engine pulley to the lower gear box pulley (Figure 2-10d).

Figure 2-10d

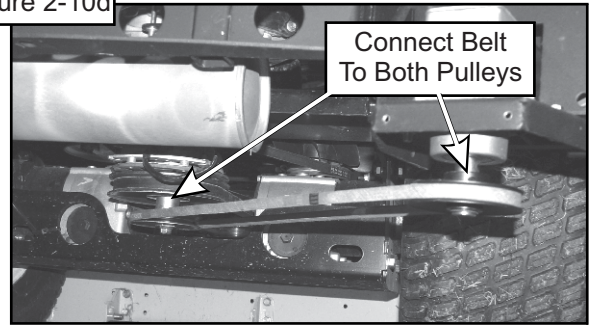

To tension the drive belt, turn the adjustment bolt clockwise (Figure 2-10e) until there is 1" of deflection, with 10-11 lbs. of pressure, at the center of the belt between the engine pulley and the gear box pulley.

Figure 2-10e

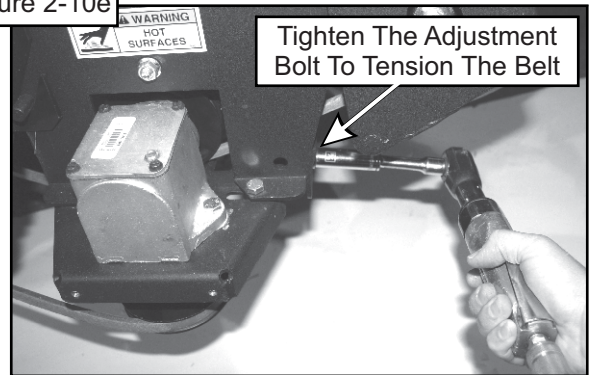

Once the correct tension of the belt is achieved, tighten the (4) bolts that secure the gear box assembly. Refer to Figures 2-10f and 2-10g. Replace the belt guard and hardware that was removed in Section 2-9.

Figure 2-10f

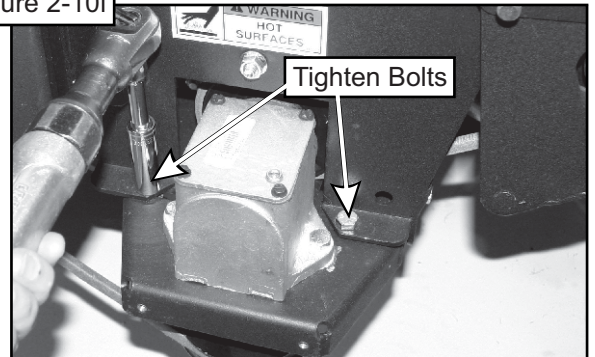
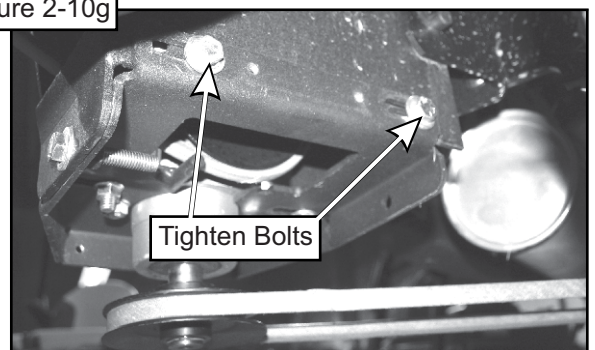

Figure 2-10g



2-11 PTO Handle Assembly

Installation

PTO MODELS ONLY

Attach the PTO handle P#(A1142) to the PTO assembly using (3) 1/4"-20 x 3/4" HHCS P#(K1222) and (3) 1/4"-20 nylon flange locknuts P#(K2014). Attach the handle grip P#(J0522) to the PTO handle. Refer to Figure 2-11.

Figure 2-11

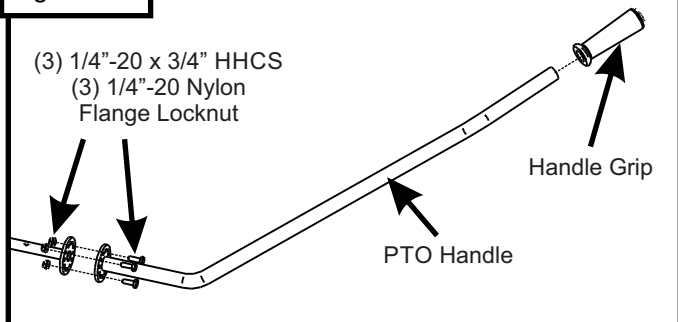

2-12 Cam Assembly Adjustment

PTO MODELS ONLY

The cam assembly P#(A0422), which controls the blower belt tension, comes from the factory pre-adjusted. If the belt is too tight or becomes too loose, remove the hair pin clip P#(K0099) from the belt tension rod P#(K0326) and pull the "L" end of the rod out of its hole in the cam assembly. The tension rod may then be screwed out to tighten the belt or screwed in to loosen the belt. Replace the "L" end into the top hole in the cam and replace the hair pin clip. Adjust the cam stop bolt P#(K1159) to allow the cam to rotate slightly over center when the blower is disengaged (Figure 2-12).

Figure 2-12

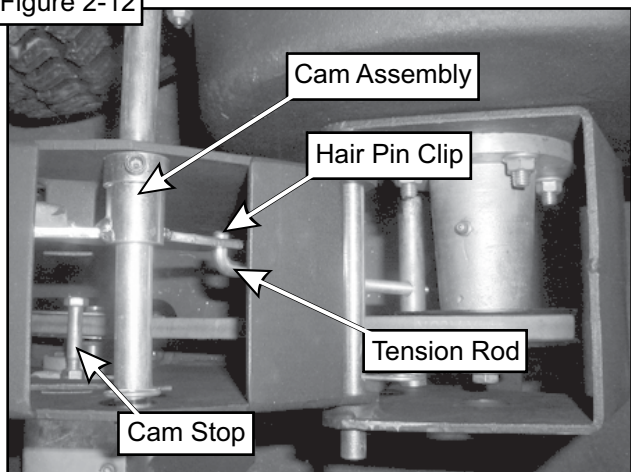

2-13 Outer Engine Mount Tube

Installation

Position the outer engine mount tube P#(B2220) as shown in Figure 2-13. Secure the outer engine mount tube to the lower mount plate using (2) 3/8"-16 x 2-18" u-bolt P#(K1119) and (4) 3/8"-16 nylon flange lock nuts P#(K2038). Orient the tube so that the detent pin mount hole is to the outside. Leave hardware finger tight until the engine/blower/blade assembly has been installed.

Figure 2-13

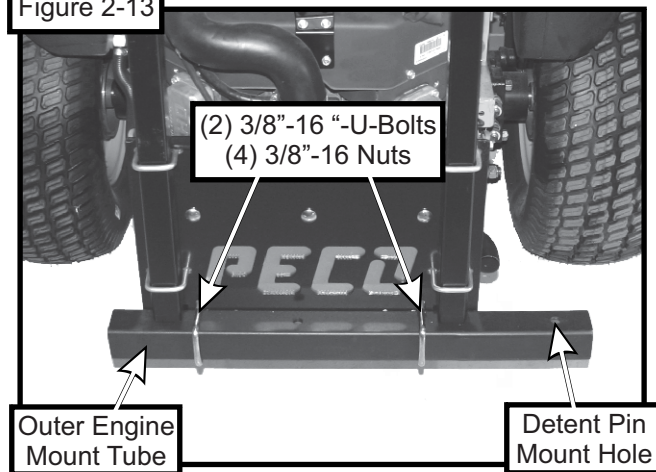

2-14 Engine Mount Arm Assembly

Installation

Insert the engine mount arm assembly P#(A0274) into the outer engine mount tube and secure using (1) detent pin P#(J0248). Refer to Figure 2-14.

Figure 2-14

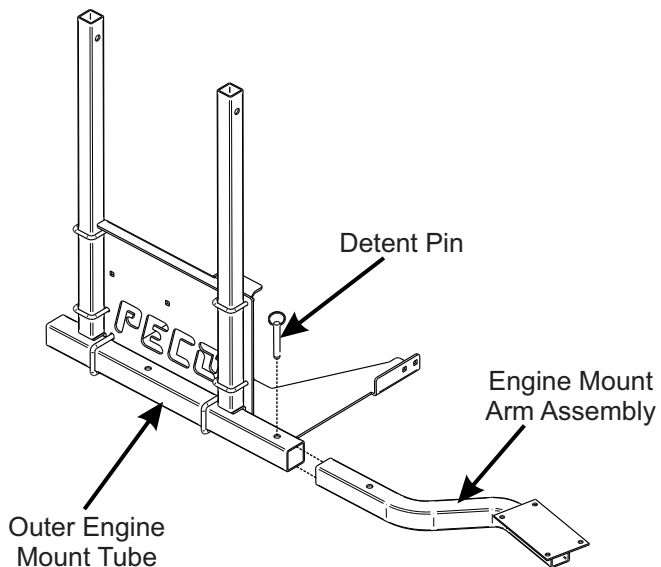

2-15 Engine/Blower/Blade Assembly Installation

Place the engine blower blade assembly on top of the engine mount arm as shown in Figure 2-15a. Secure the assembly using (4) 5/16"-18 x 1-1/2" HHCS P#(K1157) and (4) 5/16"-18 nylon flange lock nuts P#(K2516) as shown in Figure 2-15b. Tighten all hardware in Section 2-13.

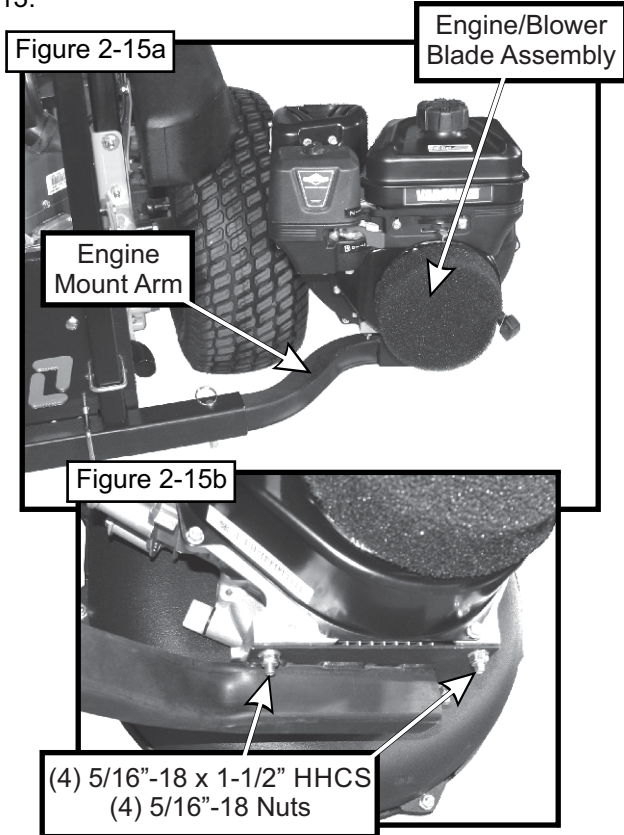

2-16 Blower Cone Installation

Thread (1) 5/16"-18 jam nut P#(K0120) onto each end of (2) 5/16"-18 x 2-1/2" HHCS P#(K0125). Now partially thread the bolts into each of the two tabs located on the blower housing. Place blower cone so the two tabs line up with the bolts then tighten completely (Figure 2-16).

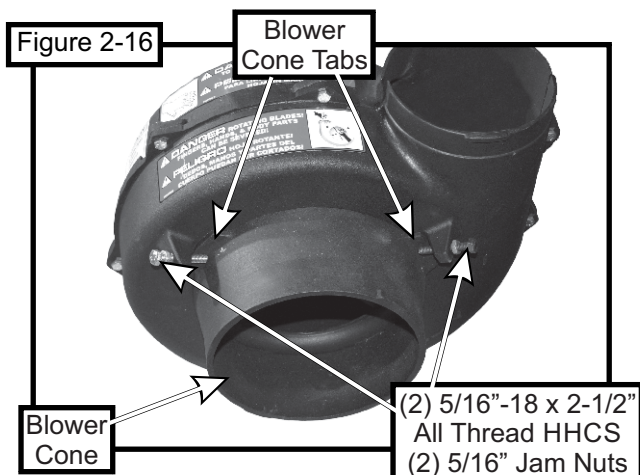

2-17 Inlet Installation

Slide the inlet P#(V0025) into the hole on the bagger top until the inlet locks into place. The inlet should pivot 360 degrees about the hole in the bagger top. Refer to Figure 2-17.

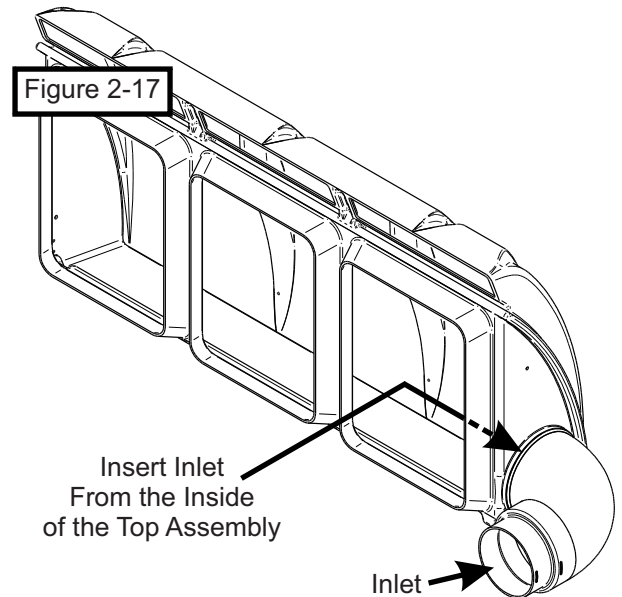

2-18 Boot To Mower Deck Installation

Position the boot plate P#(B0309) on top of the aluminum boot P#(E0012) as shown in Figure 2-18a. Secure the boot plate to the boot using (2) 3/8"-16 x 1" carriage bolts P#(K1182) and (2) 3/8"-16 nylon flange lock nuts P#(K2038). Insert the bolts from the inside of the boot so that the threads are on the outside of the boot. This will prevent any grass clippings from collecting on the threads. To attach the boot to the mower deck, lift the grass deflector and hook the tabs on the boot plate under the deflector hardware as shown in Figure 2-18b.

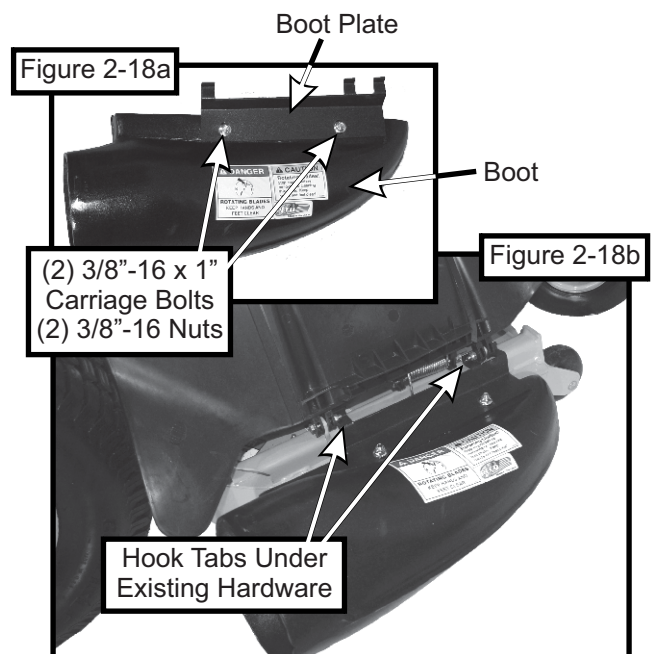

2-19 Length Of Hose Adjustment

The hoses in steps 2-20 and 2-21 must be cut to fit your machine. Follow steps 2-20 and 2-21. do not cut the hoses until you have tried to fit them on your machine. Remember that the hoses have to be long enough to adjust for the blower assembly's movement as well as allow for enough clamping surface between the inlet, blower assembly, and the deck boot.

2-20 Upper Hose Installation

Slide a 6" hose clamp P#(J0060) onto both ends of the 6" upper hose (Figure 2-22). Then slide one end of the 6" hose onto the inlet. Make sure there is about a two-inch overlap between the hose end and the container inlet. Proceed to slide the opposite end of the 6" hose onto the outlet of the blower assembly. See (Figure 2-22) for details. Make sure both ends of the hose are clearly attached to the inlet and the blower assembly inlet. Tighten the hose clamps.

2-21 Lower Hose To Blower Cone Installation

Slide a 8" hose clamp P#(J0080) over both ends of the lower hose. Then proceed to slide the lower hose onto the blower cone. Tighten the hose clamp. The assembly should look like Figure 2-22.

2-22 Lower Hose To Boot Installation

Take the unattached end of the lower hose and slide it over the circular end of the boot. Use the lower hose clamp to secure the hose to the boot (Figure 2-22). Tip: Before securing clamp rotate hose counter-clockwise (away from yourself) approximately 1" to aid in retaining boot to mower deck.

Figure 2-22

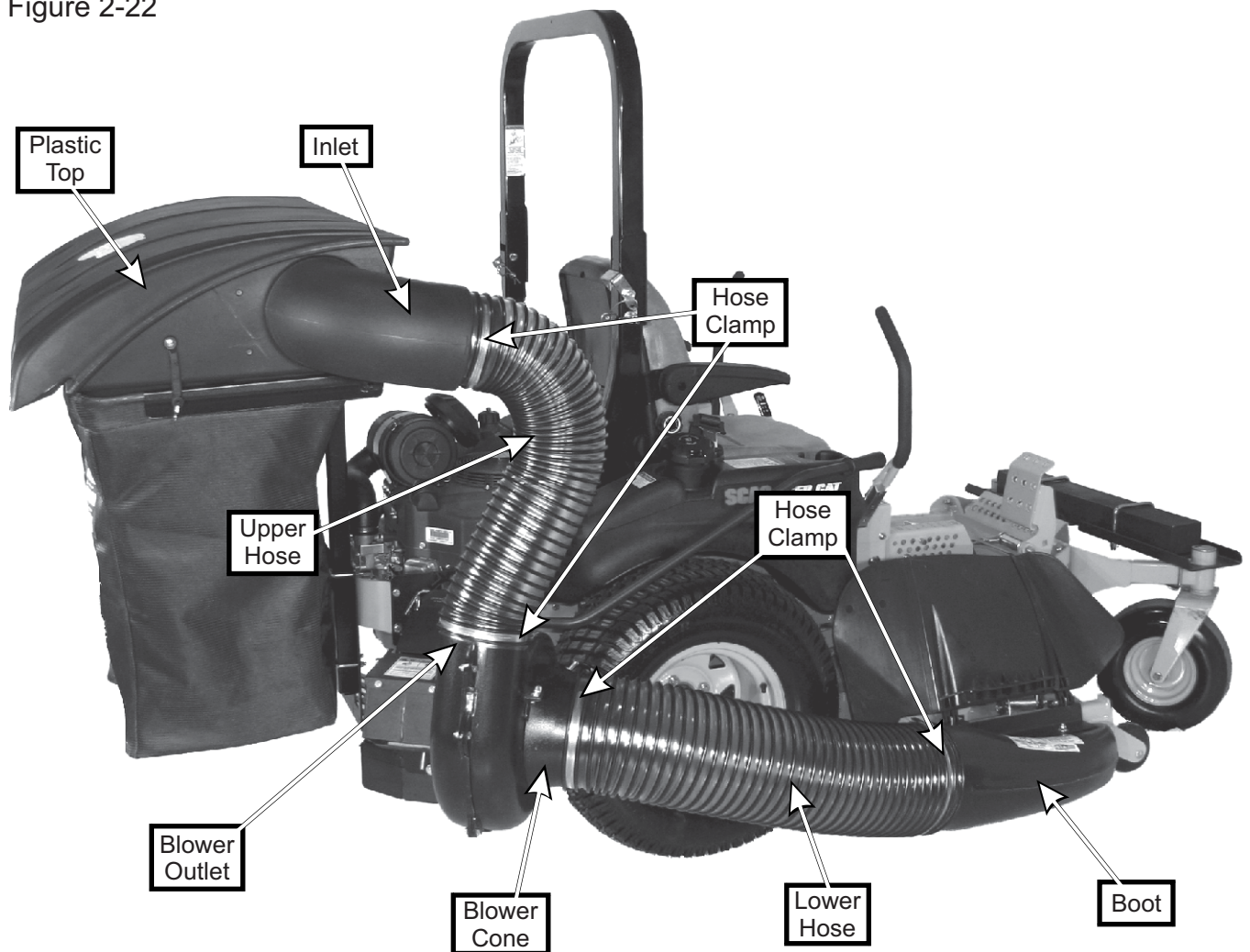

2-23 Impeller Blade Removal/Replacement

To gain impeller blade (#1) access, first remove the blower cone (#2) from the blower housing, located on the PTO assembly P#(A1821), by removing two blower cone bolts and nuts (#3). Next, remove the blower housing front (#4) by removing seven bolts and nuts (#5) around the outer housing edge. Refer to Figure 2-23.

To Remove: First, remove one 3/8"-16 x 1-1/2" HHCS P#(K1211) (#6), one taper-lock bushing washer P#(K0278) (#7) and one spacer bushing P#(S3242) (#8) from the taper-lock bushing (#9). See Figure 2-23. Next, remove two 1/4"-20 x 1" HHCS (#10) and place them into the threaded holes (#11) of the taper-lock bushing P#(S4302). Last, gradually thread each bolt evenly into the taper-lock bushing, forcing the blade to break-away from the taper-lock bushing.

Tips on removing impeller blade;

- 1 - Try carefully hitting the base of the impeller blade (#1), between each vein (#12), with a rubber mallet to loosen the taper-lock bushing hold.
- 2 - Spray break-free lubricant into the surrounding areas of the taper-lock bushing (#9) and repeat Tip 1.

To Replace: First, place the impeller blade (#1) over the drive shaft (#13). Next, slide the taper-lock bushing (#9) on to the drive shaft and into the impeller blade, aligning the **non-threaded** holes (#14) of the taper-lock bushing to the threaded holes of the impeller blade. Then, fasten by using two 1/4"-20 x 1" HHCS (#10), one spacer bushing (#8) one taper lock bushing washer (#7), and one 3/8"-16 x 1-1/2" HHCS (#6). Torque all bolts to the specifications located in the chart towards the back of this manual. Last, rotate the impeller blade to ensure that the blade is clear of contact on all sides of the blower housing.

Figure 2-23

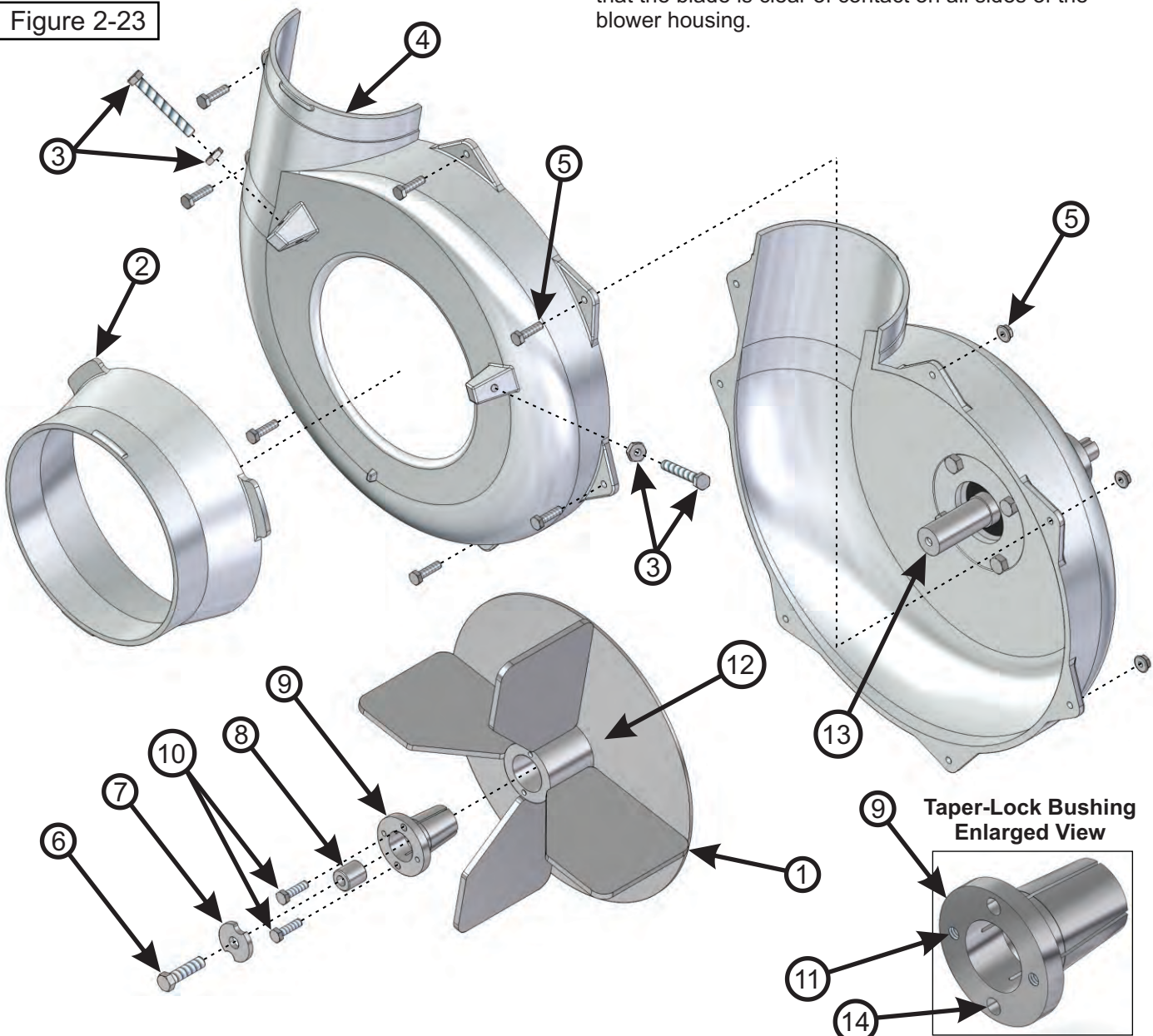

2-24 Weight Kit Installation

The collection system requires that a weight kit is installed to the front of the mower to counter-balance the weight of the collection system, when filled with debris.

NOTE: The (2) weight brackets are secured to the caster supports first. Then the weight is added to the weight brackets. It is recommended that two people perform this procedure. If another person is not available, use a rolling hydraulic floor jack to keep the weight into position while you secure the weight to the weight brackets

Locate the (2) weight brackets P#(B0026). Secure (1) bracket to each front caster support, using (1) 3/8"-16 x 2-1/8" u-bolt P#(K1119) and (2) 3/8"-16 nylon flange lock nuts P#(K2038) **PER BRACKET**. Position the weight bracket as shown in Figure 2-24a. Insert the u-bolt from the bottom of the caster support tube as shown in Figure 2-24b. Leave the hardware slightly loose until the weight has been installed.

After the weight brackets have been secured to the caster supports, place (1) weight bar P#(B0035) onto the (2) weight brackets. It is strongly recommended that someone assist you in lifting the weight bar into position. Center the weight bar between the front casters. Secure the weight bar to the weight bracket using (2) 1/2"-13 x 4-5/16" u-bolts P#(K0331) and (4) 1/2"-13 nylon flange lock nuts P#(K2012). Tighten the weight bracket hardware at this time. Refer to Figure 2-24c and 2-24d for reference.

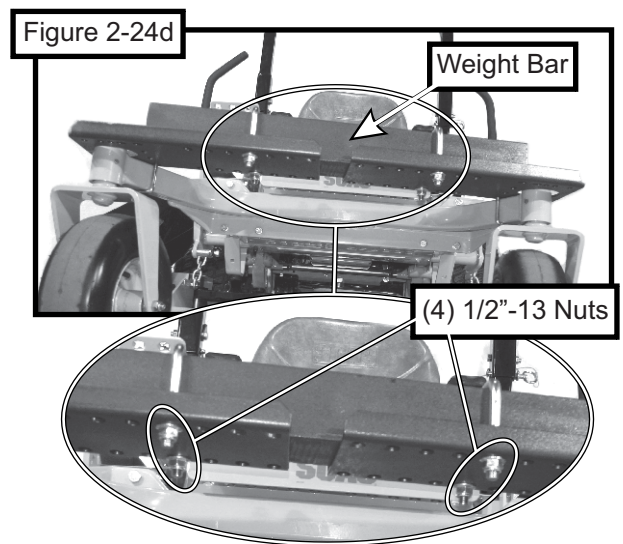
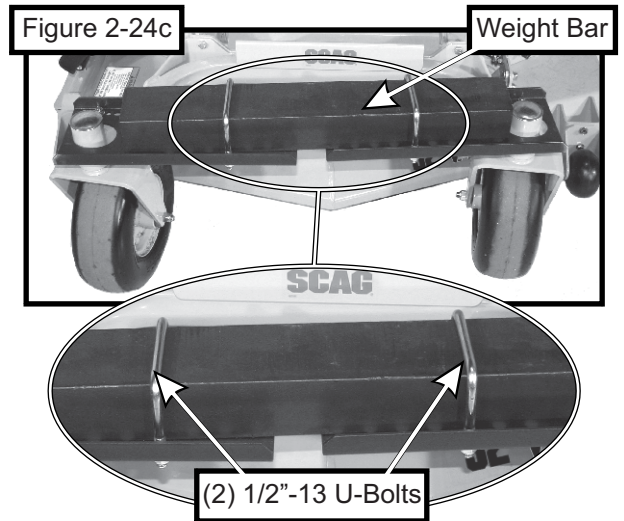
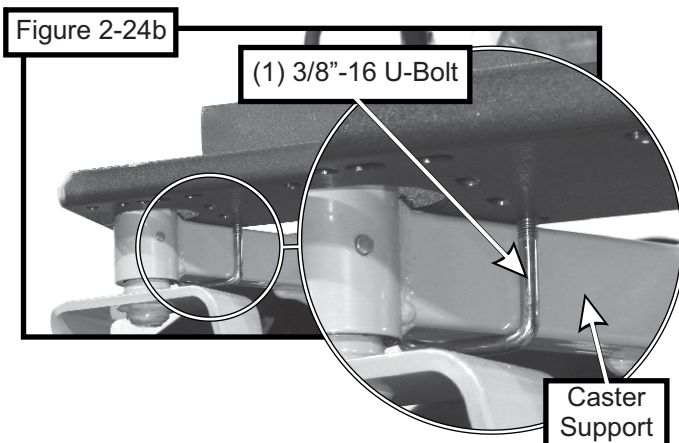
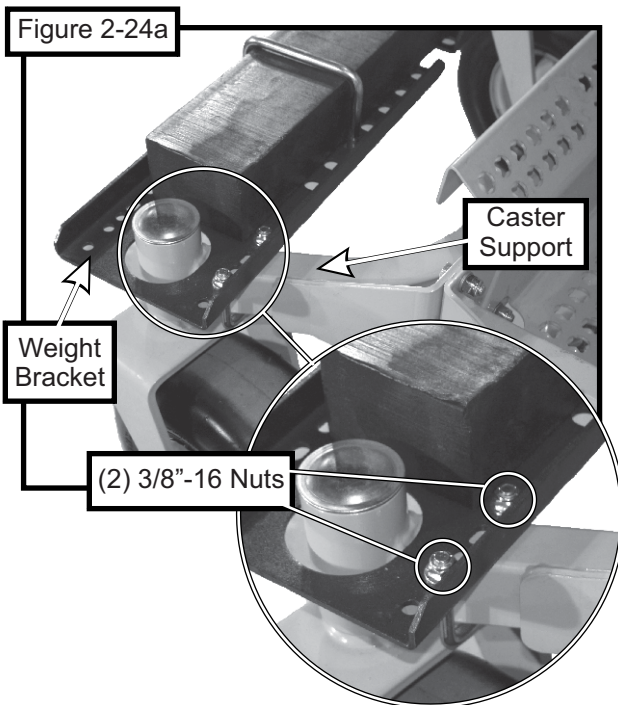

2-25 Installation/Removal Of Collection Bags

IMPORTANT!

To prevent bag wear, install (2) red plastic end caps P#(J0274), as shown in Figure 2-25a, on each bag ring before installing bags.

Figure 2-25a

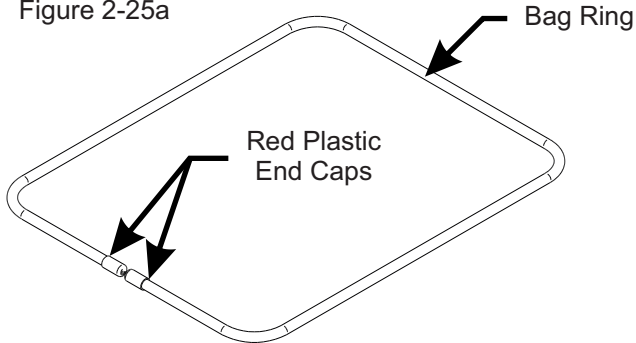

To install the bag onto the bag ring, place the seam openings of the bag onto the bag ring openings and turn the bag one full turn (360°) so the plastic end caps are located opposite to the opening in the bag (Figure 2-25b). Do this for each of three bags.

Figure 2-25b

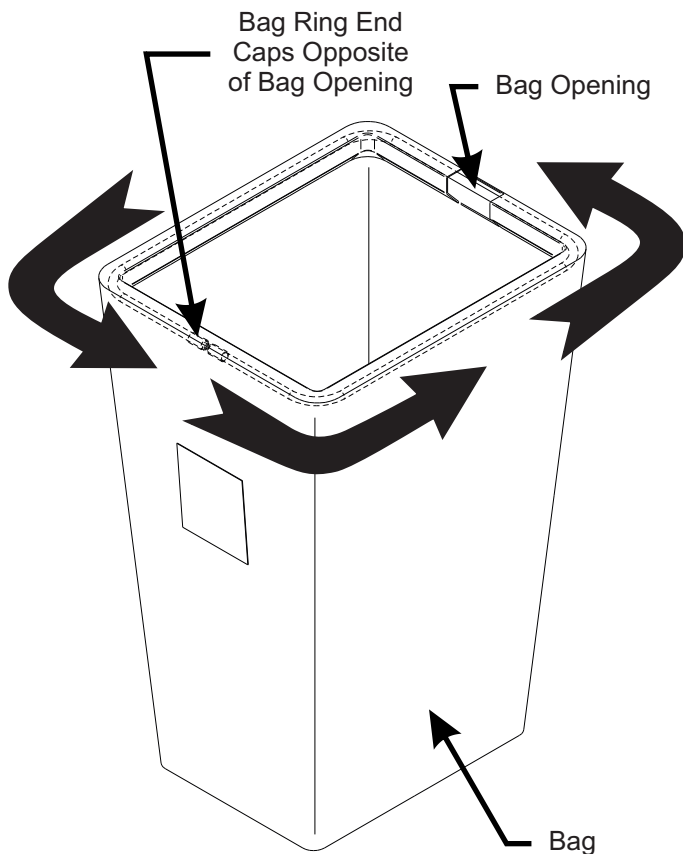

Install the completed assemblies onto the support frame and close the plastic top. Fasten both draw-latches to hold the plastic top closed (Figure 2-25c).

Figure 2-25c

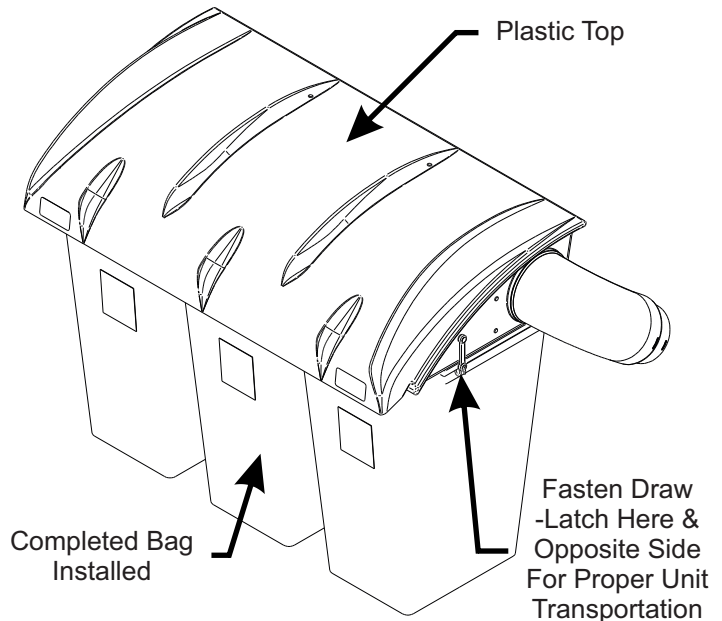

To empty the bag, first unlatch and lift top, next remove the bag and bag ring by sliding rearward, then grasp the loop on the bottom of the bag, and last turn it upside down to empty the collected debris (Figure 2-25d). Repeat for the other bags, line with plastic bags if desired, close the plastic top and reattach the draw latches.

Figure 2-25d

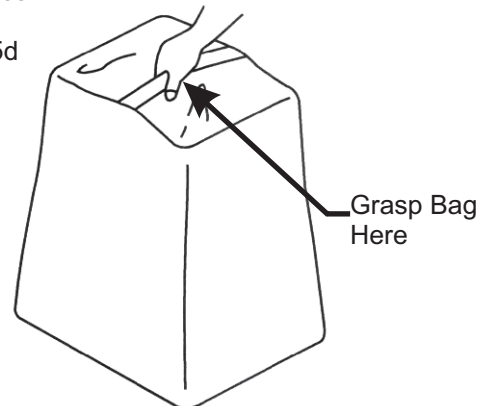

Plastic lawn and leaf bags, 33 gallon size, may be used inside the cloth bags. Be sure to leave enough plastic bag hanging over the frame so the plastic bags can be twist tied before emptying (Figure 2-25e).

Figure 2-25e

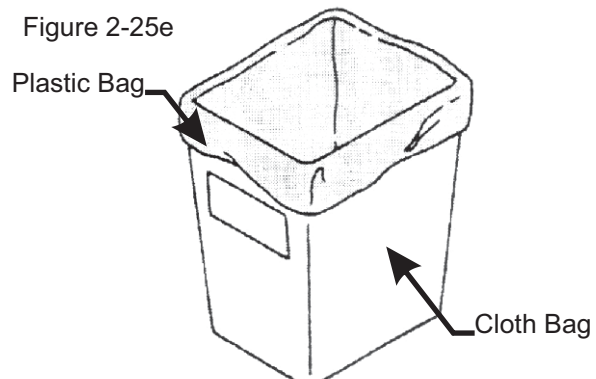

2-26 Throttle Cable Installation

NOTE: Engine Driven Models Only

To install the throttle cable kit to the ROPS (roll over protection system), place the 3/8" U-Bolt P#(K0136) onto the ROPS with the threads facing the front of the mower. Next slide on the throttle mount plate assembly P#(A0666) with the rivets also facing toward the front of the mower. Tighten the throttle mount plate assembly securely to the ROPS using (2) 3/8"16 nylon flange lock nuts P#(K2038) (Figure 2-26a). With the throttle cable facing toward the engine/blower/blade assembly, place the throttle base plate over the rivets. Slide the throttle cable kit to the right, moving the smaller end of the slot over the rivets. When positioned correctly, the throttle spring plate will snap into place (Figure 2-26b).

To remove the throttle cable kit, lift the throttle spring plate and slide the throttle kit to the left.

Route cable over the upper hose as shown in Figure 2-26c.

Figure 2-26a

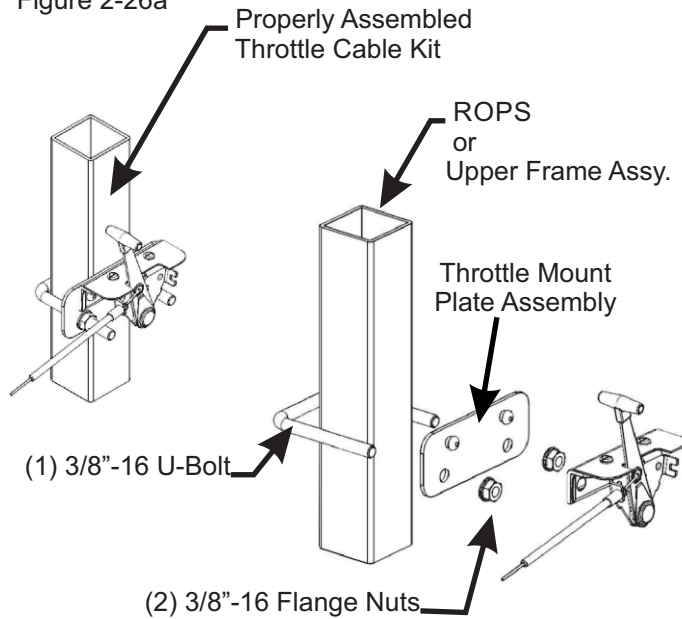

Figure 2-26b

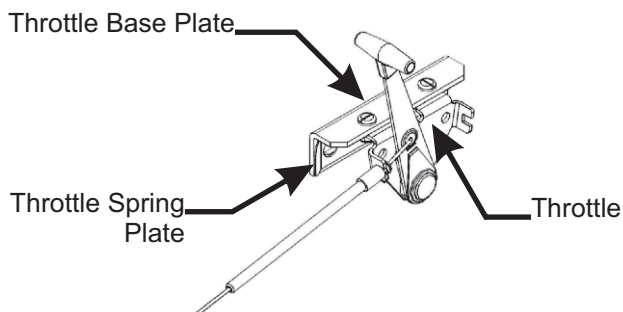
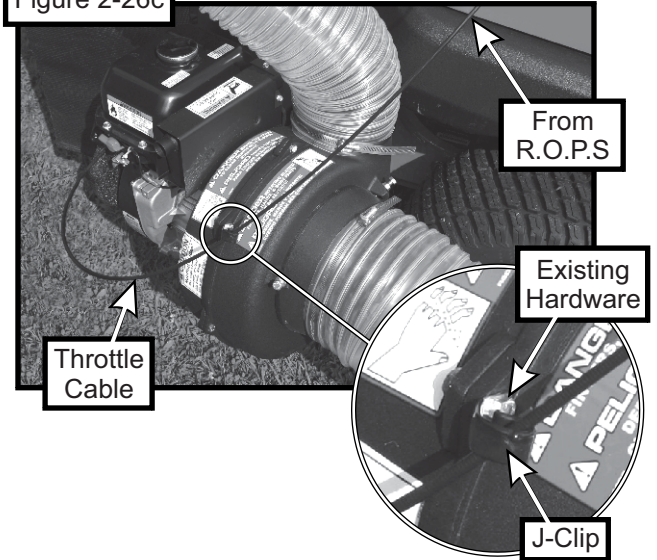

Figure 2-26c



Secure the throttle cable to the blower housing assembly using (1) J-Clip P#(K1455). Use the existing hardware from the blower housing to secure the J-Clip, as shown in Figure 2-26c.

To fasten the throttle cable end to the engine, place the throttle control lever into the "stop" position. Rotate the engine throttle lever to the "stop" position. Thread the wire end of the throttle cable into the engine throttle lever eyelet and tighten the screw. Fasten the throttle cable sleeve to the clamp on the engine throttle (Figure 2-26d). Rotate the throttle control lever into the "fast" position to check for proper installation.

NOTE: Cable sleeve may need to be cut, depending on the engine type. Once throttle cable is attached, lift the plastic top assembly and make sure that the throttle cable does not interfere with the movement of the plastic top.

Figure 2-26d

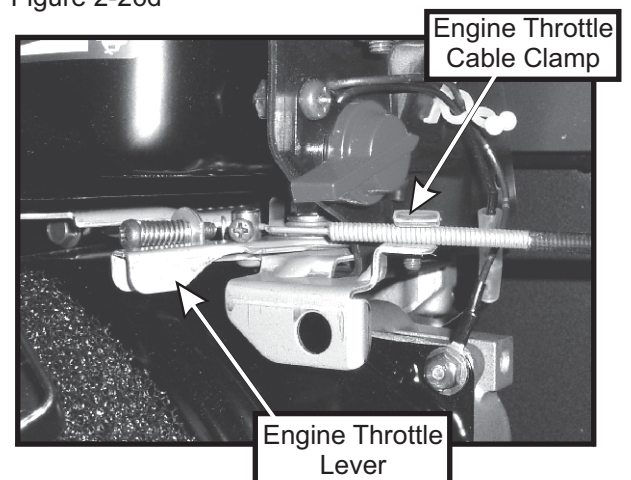

Exploded Parts View

A1157 Top Assembly

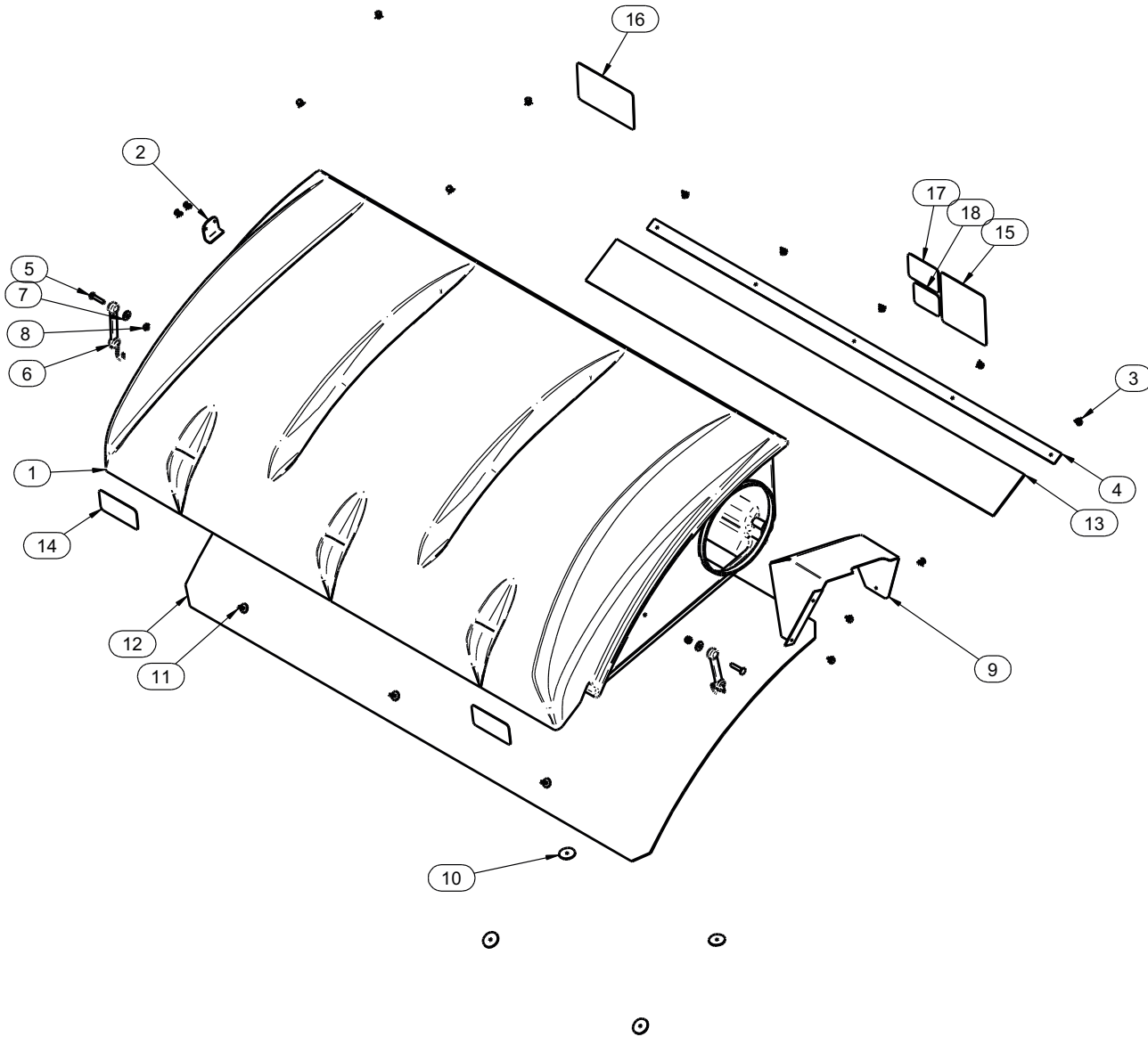

Item #	Doc #	Title	Qty
1	V0022	PRO 3 BAGGER TOP	1
2	B0676	Hinge Stop Pl.	1
3	K0114	BLACK PLASTIC RIVET	14
4	C0069	DUST GUARD BRACE	1
5	K1030	1/4"-20 x 1-1/4" CARRIAGE BOLT	2
6	J4009	SHORT RUBBER STRAP W/ S HOOK	2
7	K0037	1/4" FLAT WASHER .75 OD x .314 ID x .060 T	2
8	K1128	1/4"-20 NYLOC NUT	2
9	C0026	GRASS DEFLECTOR	1
10	K0062	3/16" x 1-1/2" FENDER WASHER, Z	4
11	K1265	BLACK PANEL RETAINER	3
12	V1120	Black Plastic Screen	1
13	V1118	DUST GUARD	1
14	R1057	2" x 4" Red Reflector Label	2
15	R1069	Warning - Turn Off Blower Label	1
16	R1065	Made In USA Label	1
17	R1054	Important Check Hoses	1
18	R1051	Warning - Use Hearing Protection	1

Exploded Parts View

A0623 PTO Assembly

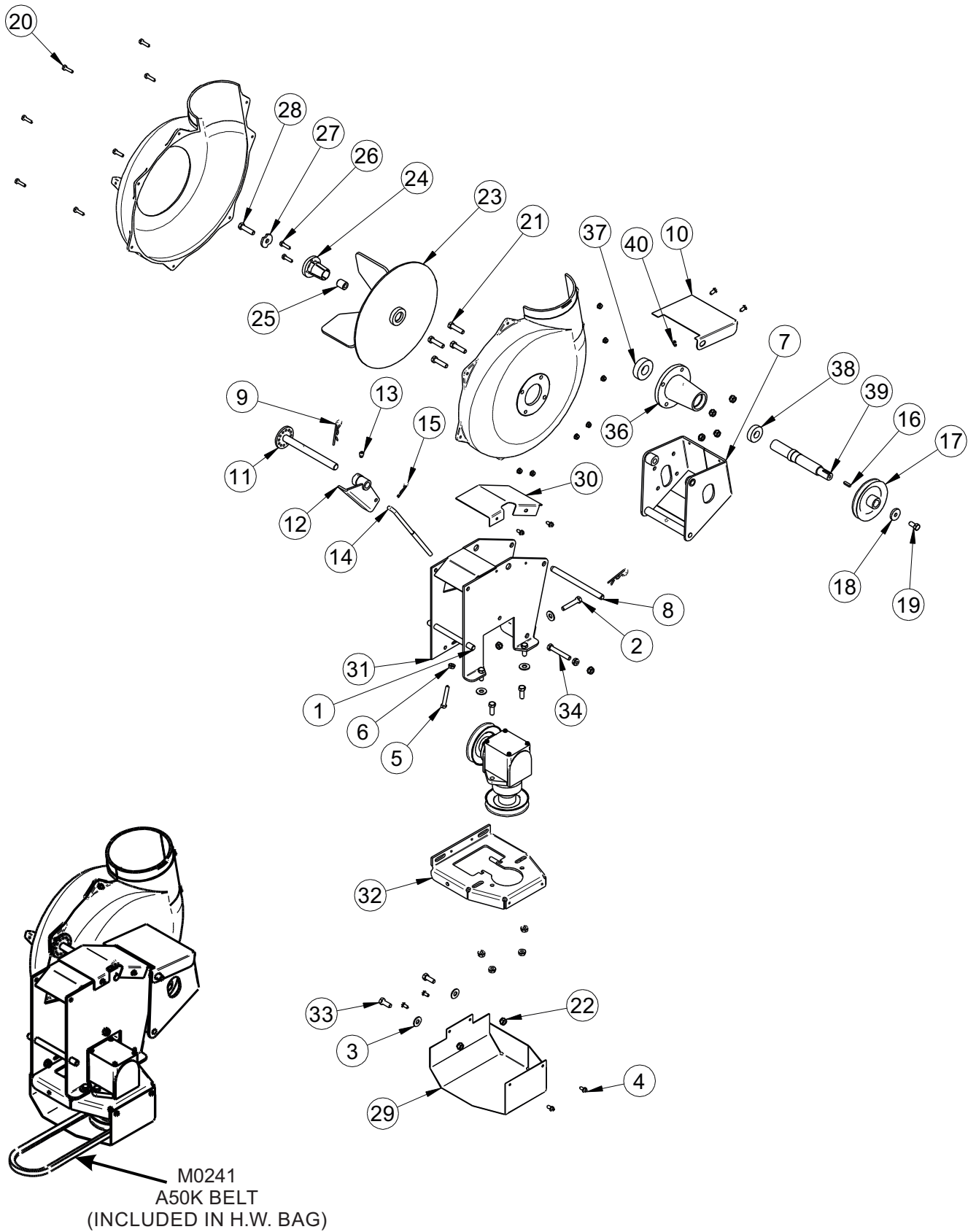

PTO Parts List

A0623 PTO Assembly

Item Number	Document Number	Title	Quantity
1	A0429	GEAR BOX ASSEMBLY	1
2	K0348	3/8"-16 x 2" ALL THREAD HHCS	1
3	K0047	3/8" FLAT WASHER 1.00 OD x .446 ID x .075 T	5
4	K0353	1/4"-20 x 1/2" HHSTS	8
5	K1159	5/16"-18 x 2" ALL THREAD HHCS	1
6	K1178	5/16"-18 FLANGE NUT	1
7	A0144	BLOWER MOUNT BRACKET ASSEMBLY	1
8	B1755	BLOWER PIVOT ROD	1
9	K0086	.125 OD x 2.50 HAIR PIN CLIP	2
10	B0121	BLOWER BELT GUARD	1
11	A0604	PTO HANDLE MOUNT ASSY	1
12	A0422	CAM BRACKET ASSEMBLY	1
13	K0356	3/8"-16 TAPERED SET SCREW	1
14	K0326	BELT TENSION ROD 3/8"-16	1
15	K0130	.091 OD x 1.625 L HAIR PIN CLIP	1
16	J0254	3/16" SQ. x 3/4" LONG KEYWAY	1
17	M0228	BLOWER PULLEY	1
18	K1446	1.187 OD x .380 ID x .187 WASHER	1
19	K1190	3/8"-16 x 3/4" HHCS	1
20	E4004A	BLOWER HSG. ASSY.	1
21	K1193	3/8"-16 x 1-1/2" HHCS	4
22	K1215	3/8"-16 FLANGE NUT	12
23	A0645	SMALL 4-BLADE IMPELLER	1
24	S4302	TAPER-LOCK BUSHING	1
25	S3242	PLATED BUSHING	1
26	K1225	1/4"-20 X 1" HHCS GRADE 8	2
27	K0278	TAPER-LOCK BUSHING WASHER	1
28	K1211	3/8"-16 x 1-1/2" HHCS GRADE 8	1
29	B0269	GEAR BOX PULLEY GUARD	1
30	B0270	PTO ARM GUARD	1
31	A0622	PTO ARM ASSY.	1
32	A0624	BASE PLATE ASSY.	1
33	K1191	3/8"-16 x 1" HHCS	6
34	K1197	3/8"-16 X 2 1/2" HHCS	1
35*	M0250	A30K KEVLAR BELT	1
36	E0121	PTO SHAFT HOUSING	1
37	N0147	BEARING 2.0472 OD, 0.9843 ID, 0.5906 W (6205RS PEER)	1
38	N0148	BEARING 1.625 OD, 0.75 ID, 0.4375 W (9R12 PEER)	1
39	B1758	PTO SHAFT	1
40	J0801	1/4"-28 ZIRC FITTING	1

Unit Model #: 37131504

Mower: Scag

Owner's Manual: Q0431

Mower Type: Tiger Cat

Engine Type: Kawasaki 24FX

Deck Size: 52" - 61"

Vac Type: 15 Cu. Ft. Pro 3 Bagger

Deck Type: Velocity Plus

Drive Type: Rear PTO Drive

Revision #:

Fits Year(s): 2012



A1829 Vac Kit

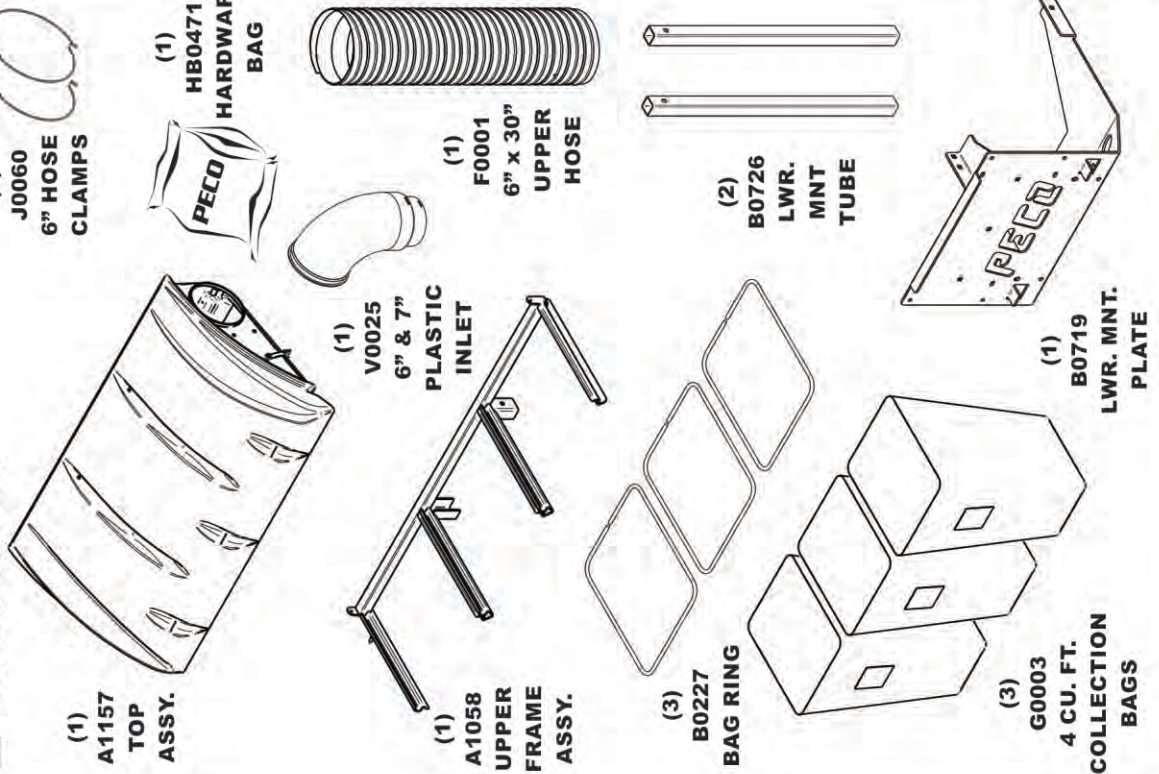

A1835 Mount Kit

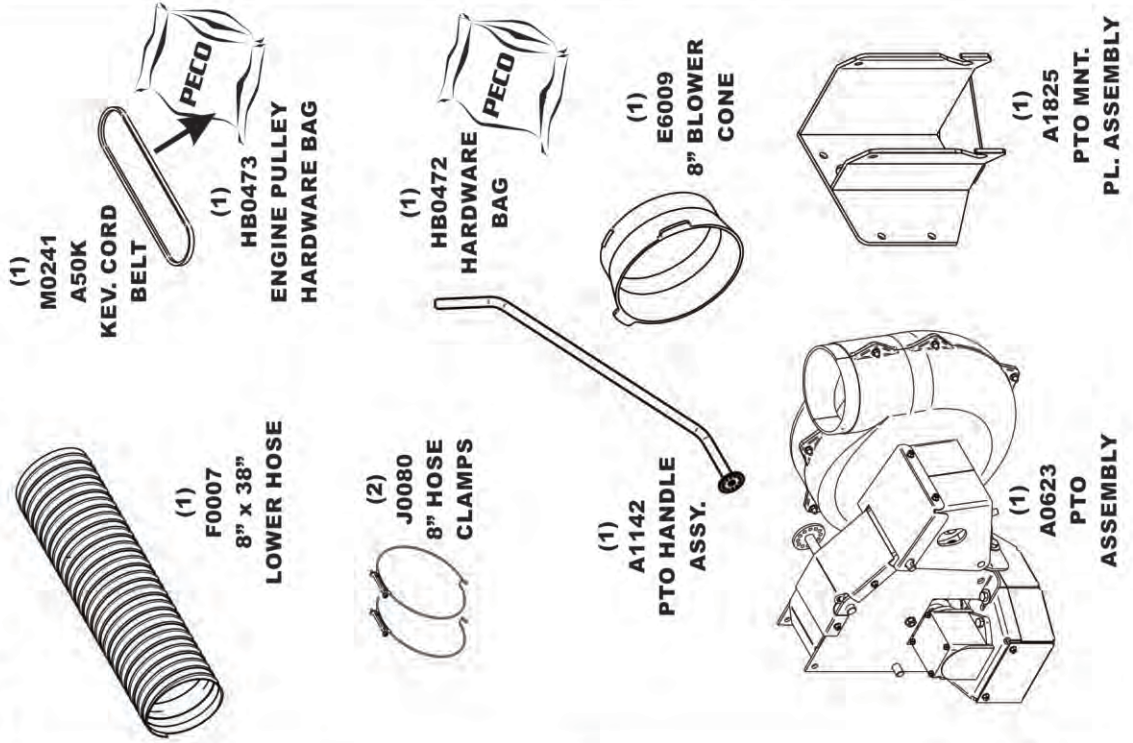

A0664 Boot Kit

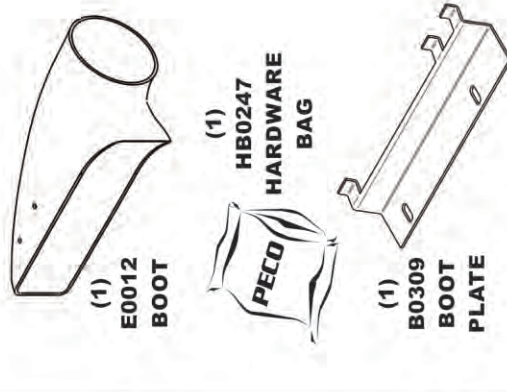

A1837 Weight Kit

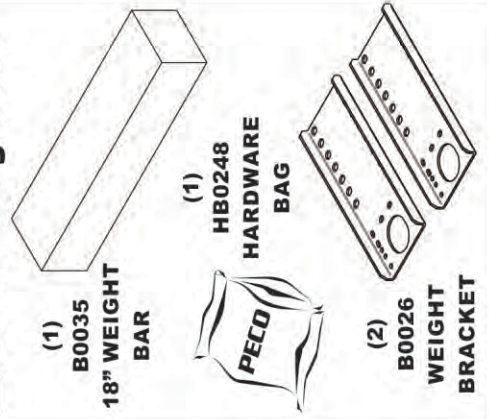

Unit Model #: 37131505

Mower: Scag

Owner's Manual: Q0431

Mower Type: Tiger Cat

Deck Size: 52" & 61"

Vac Type: 15 Cu. Ft. Pro 3 Bagger

Deck Type: Velocity Plus

Drive Type: 900 SERIES BRIGGS & STRATTON

Revision #:

Fits Year(s): 2012



A1829 Vac Kit

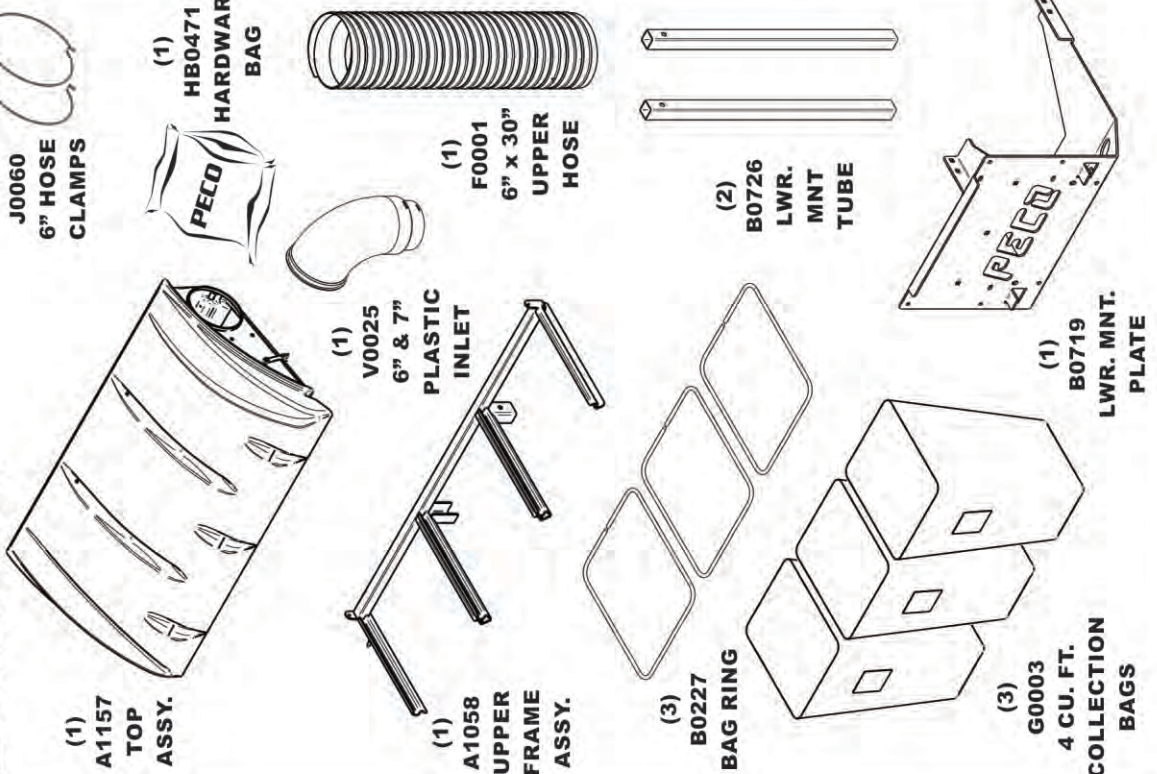

A1828 Mount Kit

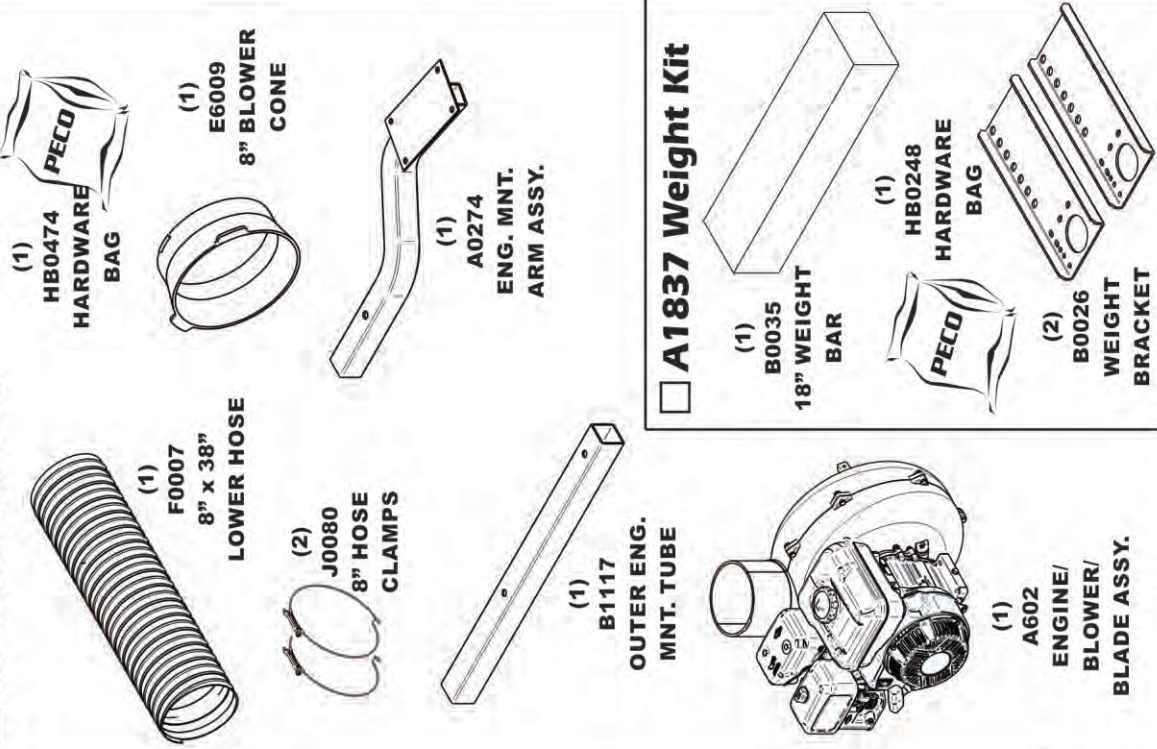

A0664 Boot Kit

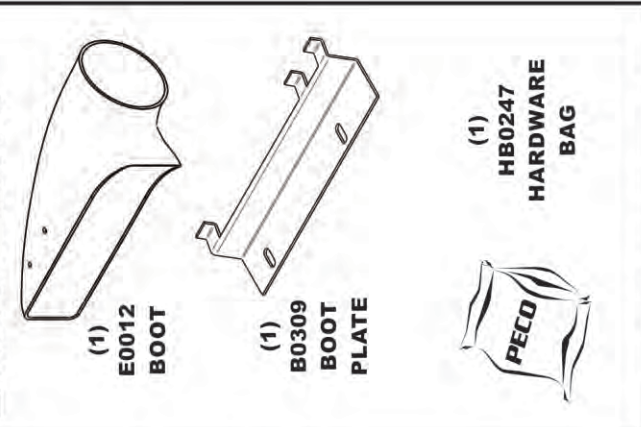

A1837 Weight Kit

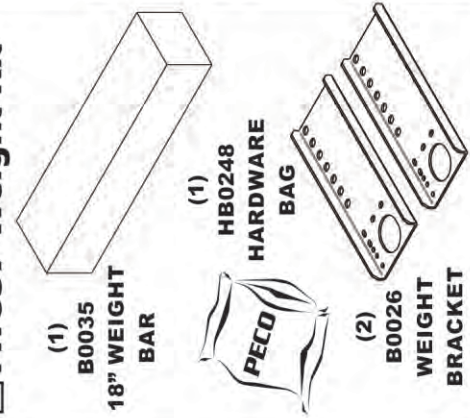

A0619 Throttle Kit

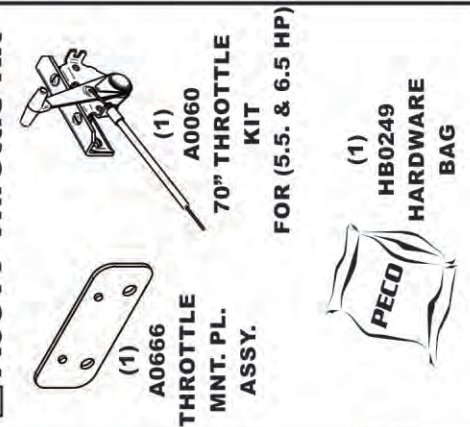

Unit Model #: 37131506

Mower: Scag

Owner's Manual: Q0431

Mower Type: Tiger Cat

Deck Size: 52" & 61"

Deck Type: Velocity Plus

Vac Type: 15 Cu. Ft. Pro 3 Bagger

Drive Type: 6.5HP B&S Vanguard Engine

Fits Year(s): 2012

Revision #:



A1829 Vac Kit

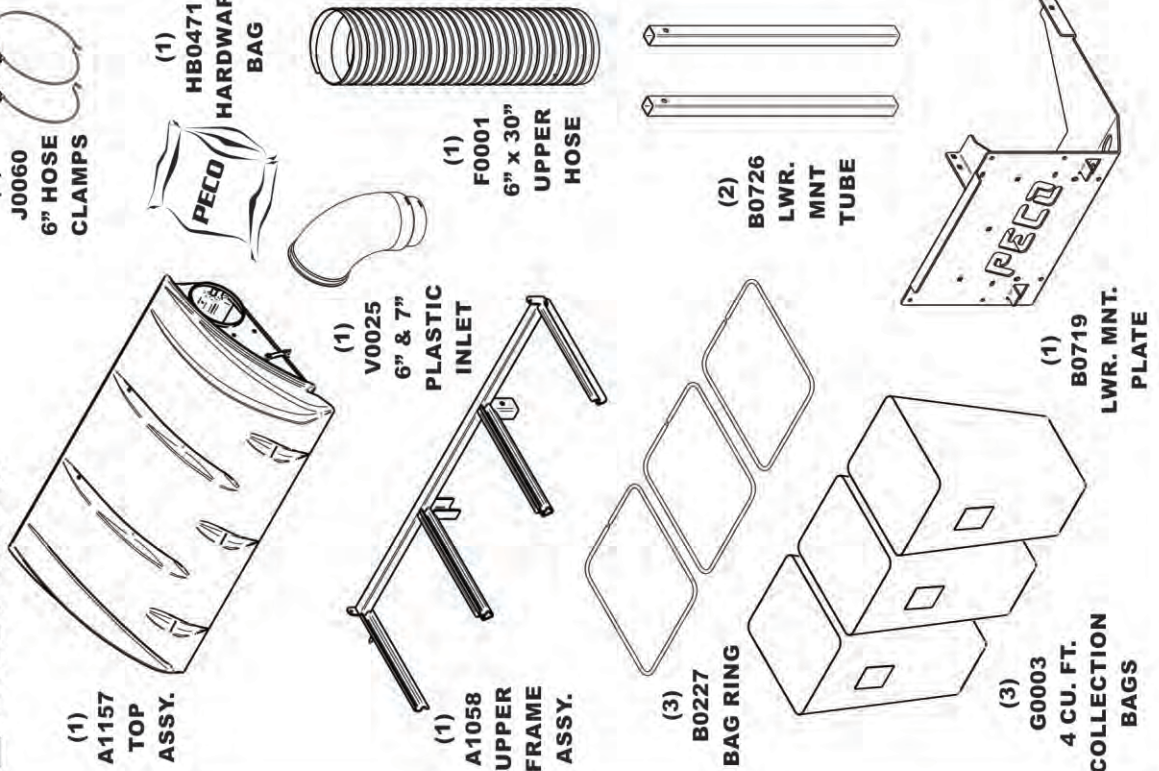

A1828 Mount Kit

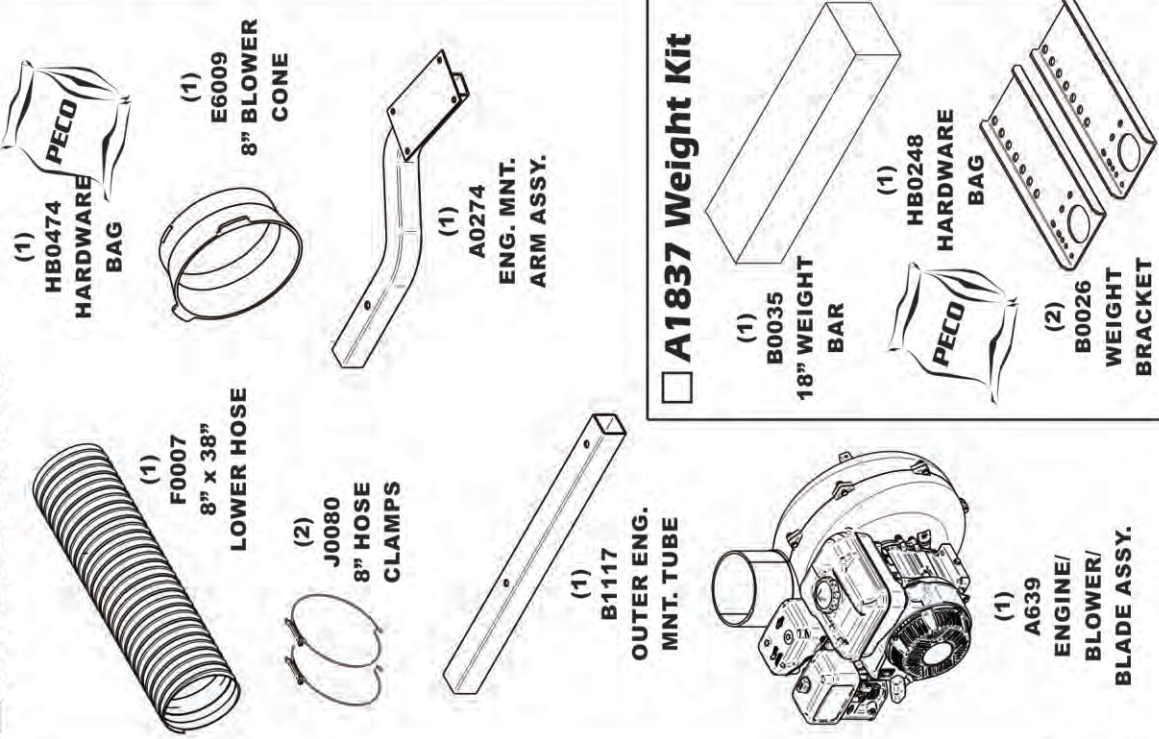

A0664 Boot Kit

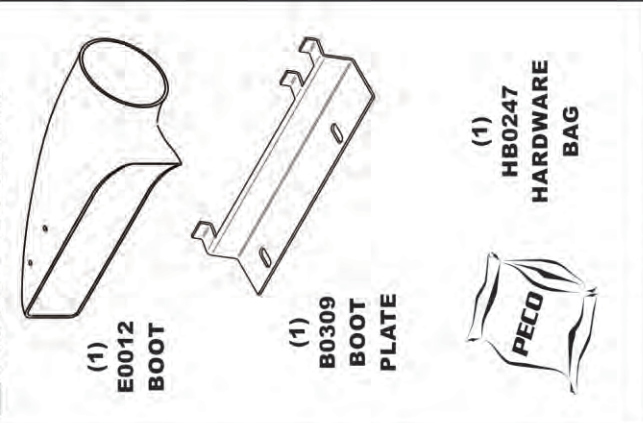

A1837 Weight Kit

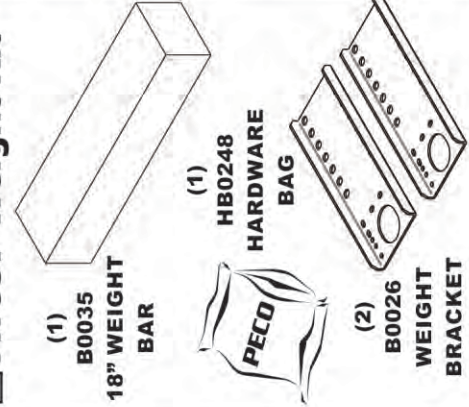

A0619 Throttle Kit

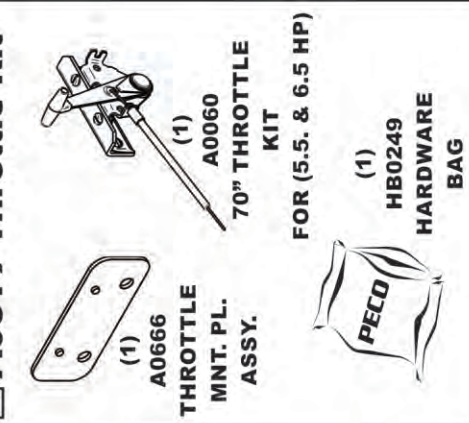

SECTION III OPERATING INSTRUCTIONS

3-1 General Safety

Only qualified people familiar with this operator's manual and the mower's operator's manual should operate this machine.

3-2 Operation And Tips On Mowing PTO MODELS

- A. Perform BEFORE EACH USE the maintenance list in paragraph 4-1.
- B. Start mower.
- C. With the mower at high idle speed, engage the mower deck.
- D. While seated in the operator's seat, rotate the engagement handle of the collection system away from the mower. Continue to rotate the handle until it stops in an over center position. With the blower engaged, you can proceed to operate the control levers of the mower.

ENGINE DRIVEN MODELS

- A. Perform BEFORE EACH USE maintenance list in paragraph 4-1.
- B. Start the engine/blower/blade assembly.
- C. Start mower.
- C. With the mower at high idle speed, engage the mower deck.
- D. Proceed to operate the control levers of the mower.

NOTE: If the collection system does not appear to be collecting the grass clippings; disengage the deck, and blower, engage the parking brake and turn the mower off. Check the upper hose, lower hose, top screen and boot for clogs. To obtain the maximum effectiveness from your collection system the tips listed below should be followed:

- * Watch your speed- Normal conditions will allow a speed of up to approximately 5 mph, but thick, heavy damp conditions will require reduced ground speed.
- * Mow with sharp blades- A sharp blade cuts cleaner.
- * Wet grass and leaves will decrease effectiveness and will increase horsepower requirements.
- * Mow at higher cutting heights- Remove and mulch no more than 2" of grass length with each mowing. (Experts recommend not cutting off more than 1/3 of the grass blade length at any given time.)
- * Mow twice, at different height settings, (high, then low), if grass is extra tall.
- * Remember that horsepower requirements will vary with the mowing conditions such as type and height of turf grass, moisture content, amount of leaves, whether the terrain is flat or hilly, etc.

3-3 Disengagement Of The Blower PTO MODELS

- A. To disengage the blower, rotate the engagement handle towards the mower.

WARNING: The blower will continue to spin. DO NOT TOUCH the blower, pulleys, or the belt until the tractor is turned off. DO NOT adjust the belt tension until the mower is turned off. Refer to section 2-10 of the manual.

ENGINE DRIVEN MODELS

- B. (5.5HP Briggs & Stratton) To stop the engine, throttle the engine to the stop position.
- C. (6.5HP Briggs & Stratton Vanguard) To stop the engine, move the fuel lever to the OFF position.

3-4 Unloading The Collection System

NOTE: To determine when the collection bags are full, follow the following steps:

- A. Stop the forward movement of the mower.
- B. Disengage the mower deck.
- C. Disengage the blower, or stop the blower engine.
- D. Engage the parking brake.
- E. Once the parking brake has been engaged, then and only then, walk behind the mower and check the collection bags by lifting the plastic hood. Load in bags should not exceed the height of the installed bag.
- F. To release bags from frame, open the plastic top and slide bags out, then turn bags over to deposit clippings.
- G. Follow steps on page 16 to re-attach bags back to the bagger.

NOTE: Do not allow collection bags to become over-filled as potential damage may occur to your equipment. Also, be sure to clean the hood screen as needed.

SECTION IV MAINTENANCE

4-1 Maintenance Checklist

NOTE: REMOVE PTO ASSEMBLY BEFORE RAISING DECK FOR MAINTENANCE.

Before each use:

1. Check blades and spindles to be sure that no foreign objects, such as wire or steel strapping bands, are wrapped around them.
2. Inspect blades for wear. Replace if necessary. If it is necessary to sharpen the blades, remove the blades from the spindles before sharpening. DO NOT sharpen blades while still attached to the mower.

3. Make sure all shields are in place and in good condition. Repair or replace any missing or damaged shields.
4. Perform lubrication per paragraph 4-2.
5. Listen for abnormal sounds, which might indicate loose parts, damaged bearings, or other damage. Correct any deficiency before continuing operation.
6. **PTO MODELS ONLY:** With the engine off, engage the blower assembly. Check the belt tension and inspect the pulley belt for cracks or tears.
7. Check for wear or deterioration of the upper or lower hoses. If there are any portions of the hose that have been torn or worn through, replace with genuine PECO parts.

After Each Use:

1. Clean all debris from machine especially from the container, underneath the belt shields, and safety decals. Replace any missing or illegible decals.
2. Inspect the unit for worn or damaged components. Repair or replace before the next use. Any replacement component installed during repair shall include the component's current safety decal specified by the manufacturers to be affixed to the component.
3. **PTO MODELS ONLY:** Check belt for proper tension.

THE SERIAL NUMBER PLATE IS LOCATED ON THE TOP ASSEMBLY P#(A1157)

PECO	
OUTDOOR POWER EQUIPMENT	
Model Number	<input style="width: 95%;" type="text"/>
Serial Number	<input style="width: 95%;" type="text"/>
Arden, North Carolina 28704	

WRITE THE MODEL AND SERIAL NUMBER IN THE BOX ABOVE FOR FUTURE REFERENCE.

4-2 Lubrication For PTO Models

NOTE: Use only white lithium based grease for lubrication of the shaft on the blower assembly.

1. On initial use: Grease the fitting on the blower shaft.
2. Every 25 hours of use: Re-grease the grease fitting.
3. Every 200 hours of use: Check oil levels in gear box. Oil in gear box should cover the gears. If necessary, fill using an EP90 weight oil. 6oz. will fill the gear box from empty.

SECTION V PARTS AND SERVICE

5-1 Parts And Service Information

PECO collection system owners should record the name and telephone number of their Service Center. Your Service Center will be happy to supply replacement parts, accessories, and do any service or repairs to your collection system. If for any reason your Service Center is unable to service your collection system or supply replacement parts, contact PECO and include the following information on the chart below.

Unit Model Number: _____
Unit Engine Size: _____
Unit Serial Number: _____
Date of purchase: ____/____/_____
Dealer/Distributor Name: _____
Address: _____ **State:** _____ **Zip:** _____
Phone Number: _____

SAFETY DECALS

To promote safe operation, PECO supplies safety decals on all products manufactured. Damage can occur to safety decals either through shipment, use or reconditioning. Contact your local Service Center for replacement decals.



Part #: R1090
Peco Pro Bagger Label



Part #: R1051
Warning: Hearing Protection Label



Part #: R1054
Important: Check Hoses Label



Part #: R4015
Danger: Rotating Blades Label



Part #: R1069
Warning: Turn Off Blower Label



Part #: R4008
Caution: Rotating Blades Label



Part #: R1057
Red Reflector Label



Part #: R1065
Made In America Label



Part #: R1052
Small Warning: Turn Off Blower Label

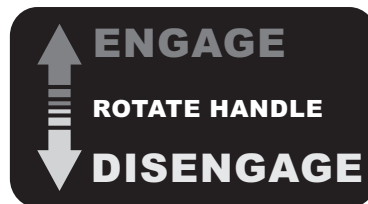

Part #: R1083
Engage/Disengage Label



Part #: R4037
Warning: Hot Surface Label



Part #: R2007
Danger: Never Use Hands Label

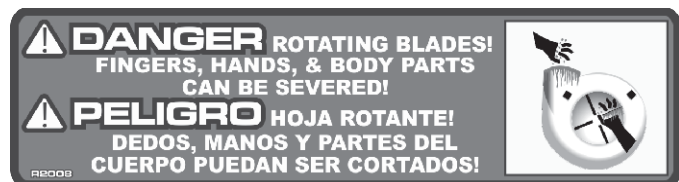

Part #: R2008
Danger: Rotating Blades Label

TORQUE SPECIFICATIONS

Proper torque for American fasteners used on Peco equipment.
Recommended Torque in Foot Pounds (Newton Meters).*

AMERICAN Bolt Head Markings

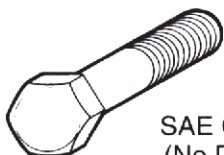

SAE Grade 2
(No Dashes)

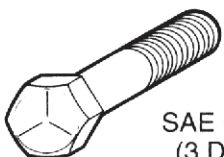

SAE Grade 5
(3 Dashes)

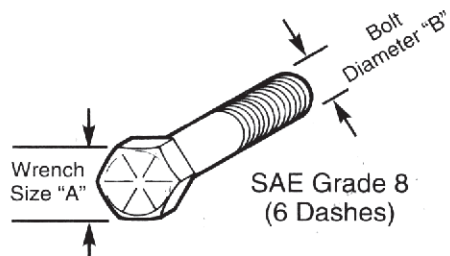

SAE Grade 8
(6 Dashes)

WRENCH SIZE (IN.) "A"	BOLT DIAMETER (IN.) "B" AND THREAD SIZE	SAE GRADE 2	SAE GRADE 5	SAE GRADE 8
7/16	1/4 - 20 UNC	6 (7)	8 (11)	12 (16)
7/16	1/4 - 28 UNF	6 (8)	10 (13)	14 (18)
1/2	5/16 - 18 UNC	11 (15)	17 (23)	25 (33)
1/2	5/16 - 24 UNF	13 (17)	19 (26)	27 (37)
9/16	3/8 - 16 UNC	20 (27)	31 (42)	44 (60)
9/16	3/8 - 24 UNF	23 (31)	35 (47)	49 (66)
5/8	7/16 - 14 UNC	32 (43)	49 (66)	70 (95)
5/8	7/16 - 20 UNF	36 (49)	55 (75)	78 (106)
3/4	1/2 - 13 UNC	49 (66)	76 (103)	106 (144)
3/4	1/2 - 20 UNF	55 (75)	85 (115)	120 (163)
7/8	9/16 - 12 UNC	70 (95)	109 (148)	153 (207)
7/8	9/16 - 18 UNF	79 (107)	122 (165)	172 (233)
15/16	5/8 - 11 UNC	97 (131)	150 (203)	212 (287)
15/16	5/8 - 18 UNF	110 (149)	170 (230)	240 (325)
1-1/8	3/4 - 10 UNC	144 (195)	266 (360)	376 (509)
1-1/8	3/4 - 16 UNF	192 (260)	297 (402)	420 (569)
1-5/16	7/8 - 9 UNC	166 (225)	430 (583)	606 (821)
1-5/16	7/8 - 14 UNF	184 (249)	474 (642)	668 (905)
1-1/2	1 - 8 UNC	250 (339)	644 (873)	909 (1232)
1-1/2	1 - 12 UNF	274 (371)	705 (955)	995 (1348)
1-1/2	1 - 14 UNF	280 (379)	721 (977)	1019 (1381)
1-11/16	1-1/8 - 7 UNC	354 (480)	795 (1077)	1288(1745)
1-11/16	1-1/8 - 12 UNF	397 (538)	890 (1206)	1444 (1957)
1-7/8	1-1/4 - 7 UNC	500 (678)	1120 (1518)	1817 (2462)
1-7/8	1-1/4 - 12 UNF	553 (749)	1241 (1682)	2013 (2728)
2-1/16	1-3/8 - 6 UNC	655 (887)	1470 (1992)	2382 (3228)
2-1/16	1-3/8 - 12 UNF	746 (1011)	1672 (2266)	2712 (3675)
2-1/4	1-1/2 - 6 UNC	870 (1179)	1950 (2642)	3161 (4283)
2-1/4	1-1/2 - 12 UNF	979 (1327)	2194 (2973)	3557 (4820)

METRIC

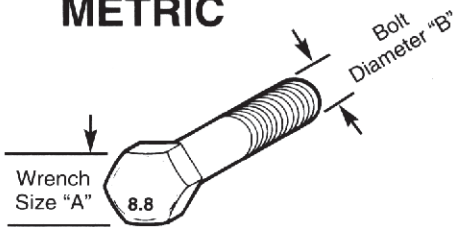

Numbers appearing on bolt heads indicate ASTM class.

*Use 75% of the specified torque value for plated fasteners. Use 85% of the specified torque values for lubricated fasteners.

Proper torque for metric fasteners used on Peco equipment.
Recommended torque in foot pounds (newton Meters).*

WRENCH SIZE (mm) "A"	BOLT DIA. (mm) "B"	ASTM 4.6	ASTM 8.8	ASTM 9.8	ASTM 10.9
8	5	1.8 (2.4)		5.1 (6.9)	6.5 (8.8)
10	6	3 (4)		8.7 (12)	11.1 (15)
13	8	7.3 (10)		21.1 (29)	27 (37)
16	10	14.5 (20)		42 (57)	53 (72)
18	12	25 (34)	74 (100)	73 (99)	93 (126)
21	14	40 (54)	118 (160)	116 (157)	148 (201)
24	16	62 (84)	167 (226)	181 (245)	230 (312)
30	20	122 (165)	325 (440)		449 (608)
33	22		443 (600)		611 (828)
36	24	211 (286)	563 (763)		778 (1054)
41	27		821 (1112)		1138 (1542)
46	30	418 (566)	1119 (1516)		1547 (2096)



**10 WALDEN DRIVE
ARDEN, NORTH CAROLINA 28704
(800) 438-5823 OR (828) 684-1234 FAX: (828) 684-0858
EMAIL: peco@lawnvac.com
WEBSITE: www.lawnvac.com**