

PROFESSIONAL BAGGING SYSTEM

MODEL# PBS



DESIGNED FOR THE BOSS AND CHARGER SERIES



OPERATOR'S MANUAL

ASSEMBLY ● OPERATION ● MAINTENANCE

MANUAL#: Q0418

Revision: 3 - 12/19/2013

PART# 629FS-001A

PROFESSIONAL BAGGING SYSTEM

TABLE OF CONTENTS

SECTION	PAGE	SECTION	PAGE
Safety	2	2-14 Impeller Blade Removal and Replacement	9
Safety Alert Symbols	3	2-15 Length Of Hose Adjustment	10
Warranty	4	2-16 Upper Hose Installation	10
I INTRODUCTION AND DESCRIPTION	5	2-17 Lower Hose To Blower Cone Installation	10
1-1 Introduction	5	2-18 Lower Hose To Boot Installation	10
1-2 Description	5	2-19 Front Weight Installation	10
II INSTALLATION FOR USE	5	Exploded Part Views and Assemblies	11-14
2-1 Preparation Of Mower	5	2-20 Installation/Removal Of Collection Bags	15
2-2 Right Mount Plate Assembly Installation	6	III OPERATING INSTRUCTIONS	16
2-3 Left Mount Plate Installation	6	3-1 General Safety	16
2-4 Lower Mount Assembly Installation	6	3-2 Operation & Tips On Mowing	16
2-5 Exhaust Deflector Installation	6	3-3 Disengagement Of The Blower	16
2-6 Universal PTO Installation	7	3-4 Unloading The Collection System	16
2-7 PTO Handle Installation	7	IV MAINTENANCE	16
2-8 Belt Installation	8	4-1 Maintenance Checklist	16
2-9 Cam Assembly Adjustment	8	4-2 Lubrication	17
2-10 Upper Frame Assembly Installation	8	V PARTS AND SERVICE	17
2-11 Top Assembly To Upper Frame Assembly Installation	8	5-1 Parts And Service Information	17
2-12 Boot To Mower Deck Installation	8	Safety Decals	18
2-13 Blower Cone Installation	9	Torque Specifications	19

Safety

1. Read the operator's manual carefully and familiarize yourself with the proper use of your attachment. Do not allow anyone who is not acquainted with the Safety Instructions to use your attachment.
2. Know the controls and how to stop quickly. READ THE OPERATOR'S MANUAL!
3. Do not allow children to operate the mower. Do not allow adults to operate the mower or grass collection system without proper instruction.
4. Be especially watchful of children and pets darting into the area while operating.
5. Keep your eyes and mind on your unit while mowing or operating your attachment. Don't let others distract you.
6. Do not attempt to operate your unit or mower when not in the driver's seat.
7. Always stop unit when emptying the container.
8. Stop unit, shut off deck attachment, set parking brake, shut off mower engine and remove spark plug wire before removing clogs, removing or replacing hose, boot, blower cone, or performing any maintenance.
9. Mow across the face of slopes (not steeper than 10 degrees); never up and down the face of the slope.
10. It is recommended that the container be kept only half full when negotiating any slopes. Start mowing on slopes when the container is empty.
11. Inspect your lawn and remove any foreign objects before mowing. Never deliberately run the mower across any foreign object.
12. Wear ear protection if the noise level is offensive.
13. Wear eye protection to prevent debris from damaging your eyes.

SAFETY

WARNING! **NEVER** operate the mower unless the discharge guard and either the deflector assembly or the vacuum collector adapter are fastened securely in place.

WARNING! Do not work around the mower deck boot or the blower area until you are certain that the mower blades and the blower impeller have stopped rotating.

WARNING! To avoid serious injury, perform maintenance on the vacuum collector; **ONLY AFTER STOPPING THE MOWER'S ENGINE AND WAITING FOR ALL MOVING PARTS TO COME TO A COMPLETE STOP.** Set the parking brake. Always remove the ignition key before beginning maintenance.

WARNING! For your own personal safety, **ALWAYS** mow **ACROSS** the face of slopes and **NEVER UP and DOWN** the face. **NEVER** attempt to mow excessively steep slopes, and use caution when turning on any slope.

Safety Alert Symbol



This Safety Alert Symbol means: **“ATTENTION! BECOME ALERT! YOUR SAFETY IS INVOLVED!”**

This symbol is used to call attention to safety precautions that should be followed by the operator to avoid accidents. When you see this symbol, carefully read the message that follows and heed its advice. Failure to comply with safety precautions could result in death or serious bodily injury.

Safety Signs

The signal words **DANGER**, **WARNING**, and **CAUTION** are used on the equipment safety signs. These words are intended to alert the viewer to the existence and the degree of hazard seriousness.



White letters on **RED**

This signal word indicates a potentially hazardous situation which, if not avoided, will result in death or serious injury.



Black letters on **ORANGE**

This signal word indicates a potentially hazardous situation which, if not avoided, could result in death or serious injury.

It may also be used to alert against unsafe practices.



Black letters on **YELLOW**

This signal word indicates a potentially hazardous situation exist which, if not avoided, will result in minor or moderate injury.

It may also be used to alert against unsafe practices.

COUNTRY CLIPPER LIMITED WARRANTY FOR NEW PRODUCTS

A. WHAT IS WARRANTED?

Country Clipper extends the following warranties to the original purchaser of each new Country Clipper bagging system subject to the following limitations:

1. PRODUCT WARRANTY: Any part of the bagging system, which is defective in material or workmanship as delivered to the purchaser will be repaired or replaced, as Country Clipper elects, without charge for parts or labor, if the defect appears within 12 months from the date of delivery of the product to the original purchaser.

ALL DEFECTIVE PARTS MUST BE RETURNED TO COUNTRY CLIPPER FOR INSPECTION TO DETERMINE VALIDITY OF WARRANTY CLAIMS. Freight and mailing will be borne by the customer.

2. PARTS REPLACED DURING WARRANTY: Any new Country Clipper bagging system which is furnished in performance of this warranty and is defective in material or workmanship as delivered to the purchaser will be repaired or replaced, as Country Clipper elects, without charge if the defect appears within 90 days from the date of installation of such part or before the expiration of the original warranty period, whichever is later.

B. SECURING WARRANTY ADJUSTMENTS.

Call Country Clipper for Return Authorization. Damaged or broken parts, other than engines or batteries, must be returned to Country Clipper Division of Shivers Mfg. Inc., 613 W. English, Corydon, IA, 50060 before any warranty adjustment can be authorized. At the time of requesting warranty adjustment, the purchaser must present evidence for date of delivery of the product. The purchaser shall pay any charge for the product to and from Corydon, IA.

C. ITEMS NOT COVERED BY COUNTRY CLIPPER WARRANTY.

Engines, batteries, and gearboxes attached to Country Clipper products are covered under a separate warranty by the respective manufacturer.

D. UNAPPROVED ALTERATION OR MODIFICATION.

All obligations of Country Clipper, under this warranty, shall be terminated if products are altered or modified in ways not approved by Country Clipper.

E. ACCIDENTS AND NORMAL MAINTENANCE.

The warranty covers only defective material and workmanship. It does not cover depreciation or damage caused by normal wear, accident, improper use or abuse of products. The cost of normal maintenance and normal replacement of service items such as belts, cutting blades, hoses, etc., which are not defective shall be paid for by the purchaser.

F. NO REPRESENTATIONS ADDITIONAL WARRANTIES, DISCLAIMER.

Neither Country Clipper nor any company affiliated with it makes any warranties, representations or promises as to the quality of performance of its products other than those set forth herein. Except as described above, Country Clipper makes no other warranties **AND SPECIFICALLY DISCLAIMS ANY AND ALL IMPLIED WARRANTIES OF FITNESS AND MERCHANTABILITY.**

G. ANY MACHINE USED FOR RENTAL PURPOSES ARE GUARANTEED FOR 45 DAYS FROM DATE OF ORIGINAL SALE ONLY.

H. REMEDIED EXCLUSIVE.

The only remedies the purchaser has in connection with the breach or performance of any warranty on Country Clipper bagging systems are set forth above. In no event will Country Clipper be liable for special incidental or consequential damages.

1. NO SERVICE CENTER WARRANTY.

The selling Service Center makes no warranty on his own on any item warranted by Country Clipper unless he delivers to purchaser a separate written warranty certificate specifically warranting the item. The dealer has no authority to make any representation or promise on behalf of Country Clipper or to modify the terms of this warranty in any way.

SECTION I

INTRODUCTION AND DESCRIPTION

1-1 Introduction

Your grass collection system has been designed to give you a low maintenance, simple, and effective way to collect the grass clippings from your mower. This manual is provided to give you the necessary instructions to properly mount and operate the collection system on your mower. Please read this manual thoroughly. Understand what each control is for and how to use it. Observe all safety decal precautions on the machine and noted throughout the manual.

NOTE: all references made to right, left, front, rear, top or bottom are as viewed from the normal operator's position on the mower.

1-2 Description

The grass collection system is designed for turf maintenance where there is a need to collect the grass clippings as the mower cuts the turf. It is also used for picking up leaves and twigs in pre-season and post-season clean-up.

The blower, mounted on the right side of the unit, uses a belt and gearbox system from the engine PTO shaft. Drive train protection comes through belt slippage. The blower draws grass clippings from the discharge area of the cutter deck back to the (3) - 3.3 cubic foot collection bags P#(G0002) at the rear portion of the mower frame. The operator can engage the blower with a push of the over-center linkage on the right side of the unit. Once the bags are full with clippings, they can be released to make for easy dumping.

Section II

INSTALLATION FOR USE

2-1 Preparation Of Mower

Carefully dismantle the wooden shipping crate from around the components. Cut the retaining straps and separate the parts. The grass collection system will have various parts located inside. Remove and sort all parts for easy identification.

NOTE: before each step of assembly it will help to study the exploded drawings on pages 11-14.

From the underside of the engine remove the bolt and bushing from the electric clutch assembly. Use a bungee cord or similar device to hold the clutch in place while the hardware is removed.

For 25HP Kawasaki or 23,27,28,& 30HP Kohler, replace these parts with the engine pulley assembly number 6 P#(A0611), 7/16" lock washer P#(K0140), and 7/16"-20 x 3-3/4" hex bolt P#(K0350). For 31HP Kawasaki, use engine pulley assembly number 6 P#(A0611), 7/16" lock washer P#(K0140), and 7/16"-20 x 3-1/4" hex bolt P#(K0351). For 26HP Kawasaki, use engine pulley assembly number 6 P#(A0611), 7/16" lock washer P#(K0140), and M10-1.5MM x 100MM hex bolt P#(K0398). For 35HP & 37HP Kawasaki, use engine pulley assembly number 22 P#(A1174), 7/16" lock washer P#(K0140), 7/16"-20 x 2-3/4" hex bolt P#(K0397) and 1/4" x 1/4" x 1-1/2" keystock P#(K1623). The added pulley will power the collection system. Note that the center of the hub that is extended, should be upward toward the engine (Figure 2-1a). Torque the bolt to 55 ft./lbs.

Figure 2-1a

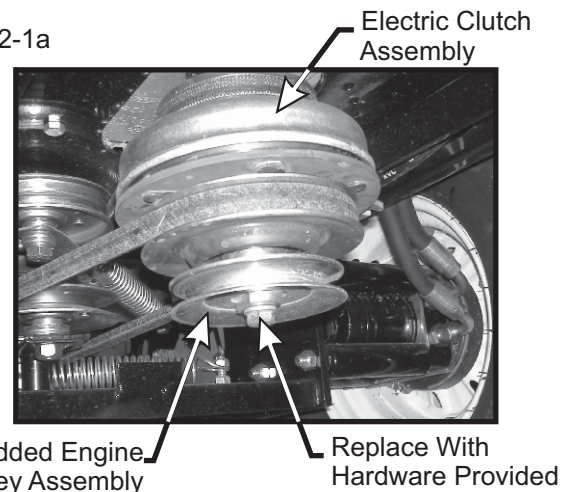

Removing The Rear Panel Guard

The rear panel guard and existing hardware must be removed from the rear frame of the mower. Refer to Figure 2-1b.

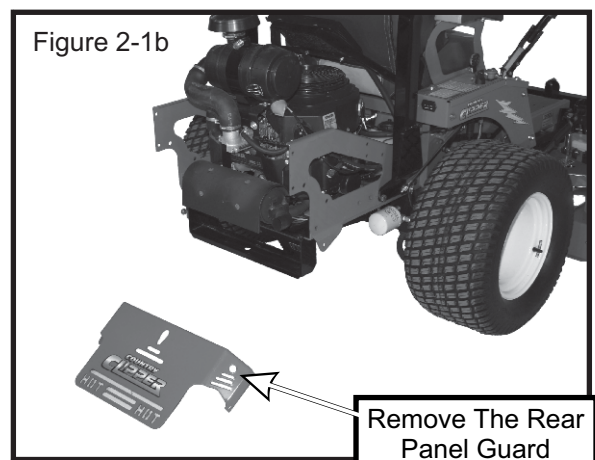

2-2 Right PTO Mount Plate Assembly Installation

Fasten the right PTO mount plate assembly P#(A1230) to the right panel guard using (2) 1/2"-13 x 1-1/2" HHCS P#(K1233) and (2) 1/2"-13 nyloc nut P#(K1247). Use existing hardware from the rear panel guard where indicated. Refer to Figure 2-2.

Figure 2-2

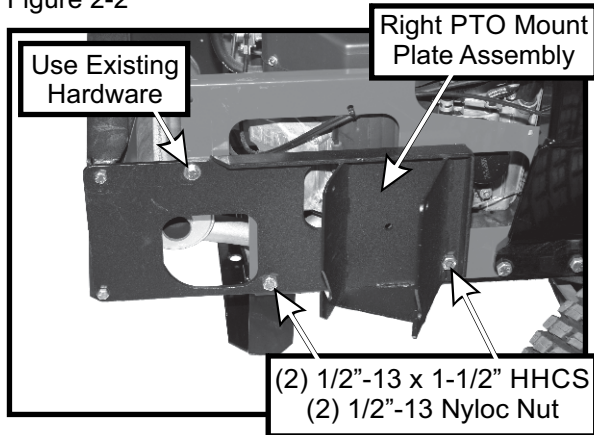

2-3 Left Mount Plate Installation

Fasten the left mount plate P#(B0661) to the left panel guard using (2) 1/2"-13 x 1-1/2" HHCS P#(K1233) and (2) 1/2"-13 nyloc nut P#(K1247). Use existing hardware where indicated. Refer to Figure 2-3.

Figure 2-3

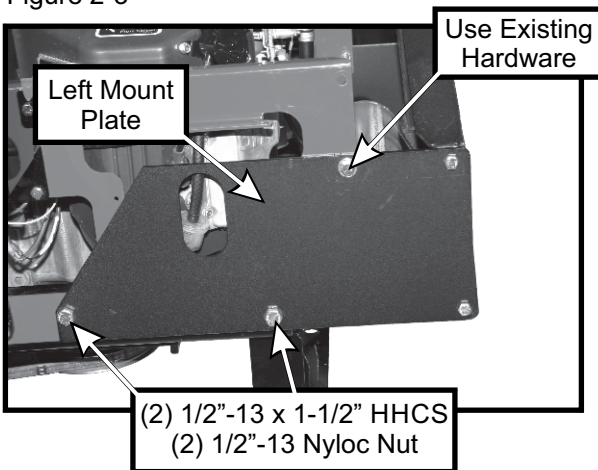

2-4 Lower Mount Assembly Installation

NOTE: It is recommended that someone assist you during the lower mount assembly installation. Lift the lower mount assembly P#(A0706) into position as shown in Figure 2-4, and fasten to the left and right mount plates, using (4) 3/8"-16 x 1-1/2" HHCS P#(K1193) and (4) 3/8"-16 nyloc nut P#(K1216). Refer to Figure 2-4.

Figure 2-4

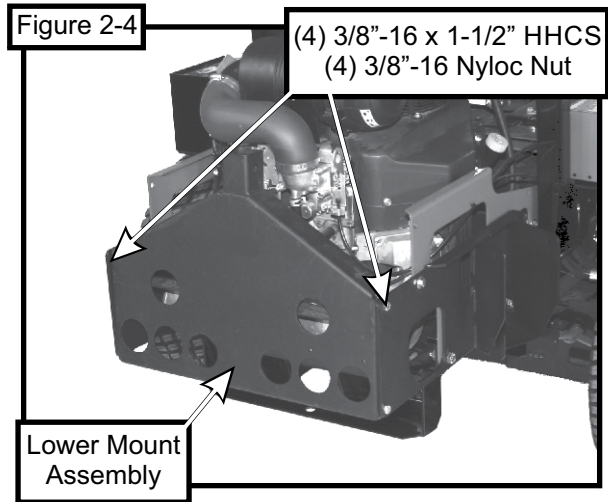

2-5 Exhaust Deflector Installation

NOTE: All engine models that divert exhaust to the left, will not require an exhaust diverter. If your engine model diverts exhaust to the rear, fasten the exhaust deflector P#(C0050) to the lower mount assembly using (2) 1-4"-20 x 1/2" HHSTCS P#(K0353). Refer to Figure 2-5a.

Figure 2-5a

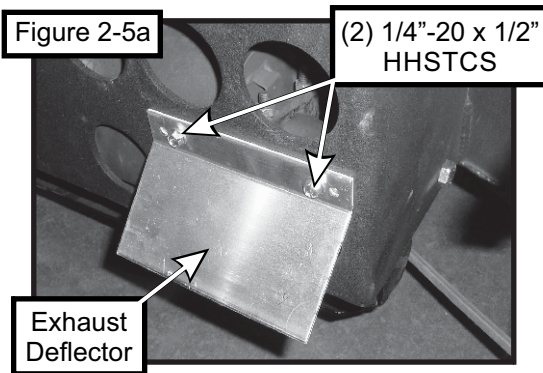

For engine models that divert exhaust to the right side, attach the exhaust deflector P#(J0282) to the muffler and secure with (1) exhaust clamp P#(X1064). See Figure 2-5b.

Rotate the deflector down slightly to prevent the exhaust from being diverted towards the collection bags.

Figure 2-5b

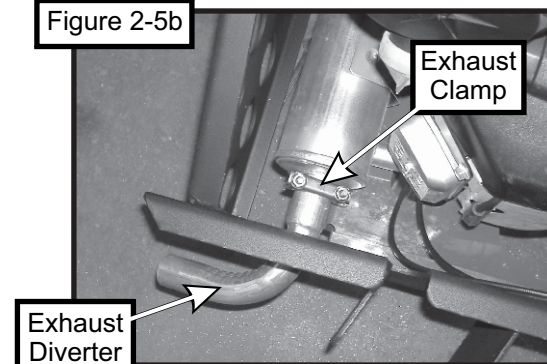

2-6 Universal PTO Installation

To mount the PTO assembly, insert the pivot rod on the PTO assembly P#(A0623) into the mounting slots located on the right PTO mount plate assembly P#(A1230). Tilt the PTO assembly upward and insert the PTO mount pin P#(B0274) through the hole in the top of the right PTO mount plate assembly. Secure the PTO mount pin using 1/8" x 2-3/8" hair pin clip P#(K0086) as shown in Figure 2-6.

Figure 2-6

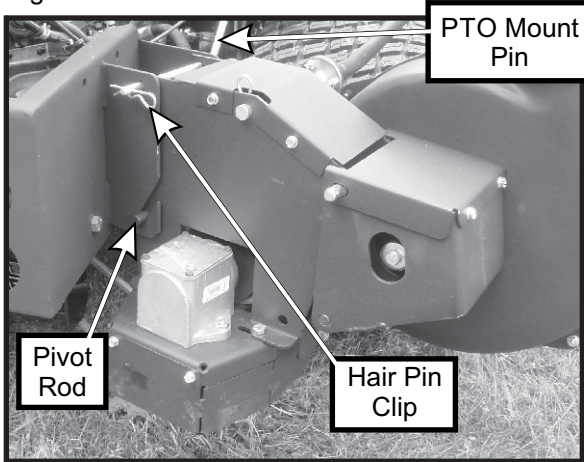

2-7 PTO Handle Assembly Installation

Mount the PTO handle assembly P#(A0603) to the universal PTO P#(A0623) using (3) 1/4"-20 x 3/4" HHCS P#(K1222) and (3) 1/4"-20 nyloc nuts P#(K1128). Before fastening, make sure that there is room for the handle to engage and disengage without the handle hitting the mower's fuel tank. Attach the handle grip P#(V1151) to the PTO handle assembly. See Figure 2-7 for reference.

Figure 2-7

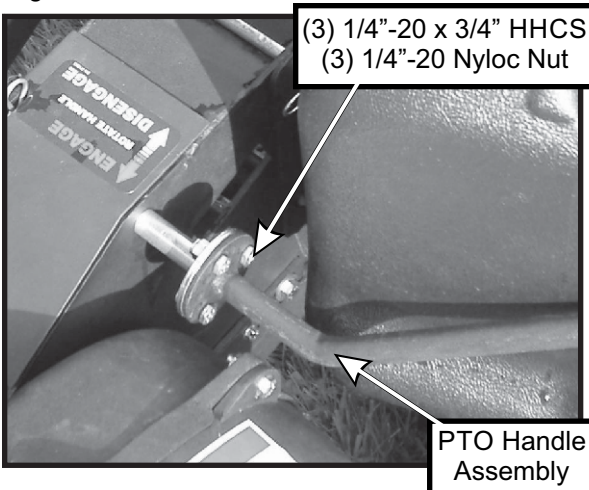

2-8 Belt Installation

Remove the belt guard. Loosen the (4) bolts P#(K1191), (2) on each side, that secure the gear box assembly to the PTO assembly P#(A0623) (Figure 2-8a and 2-8b). Loosen the adjustment bolt P#(K0348) until the gear box assembly is at its far left adjustment (the gear box is moved toward the mower's engine pulley). Connect the kevlar cord belt A50K P#(M0241) from the engine pulley to the lower gear box pulley (Figure 2-8c). To tension the drive belt, turn the adjustment bolt clockwise until there is 1" of deflection, with 10-11 lbs. of pressure, at the center of the belt between the engine pulley and the gear box pulley. Once the correct tension of the belt is achieved, tighten the (4) bolts that secure the gear box assembly. Replace the belt guard.

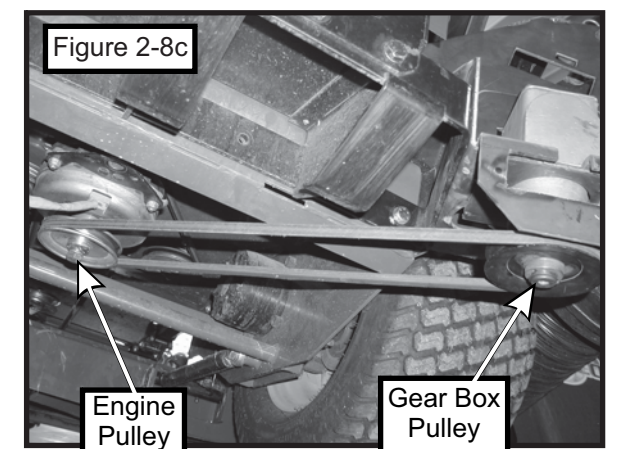
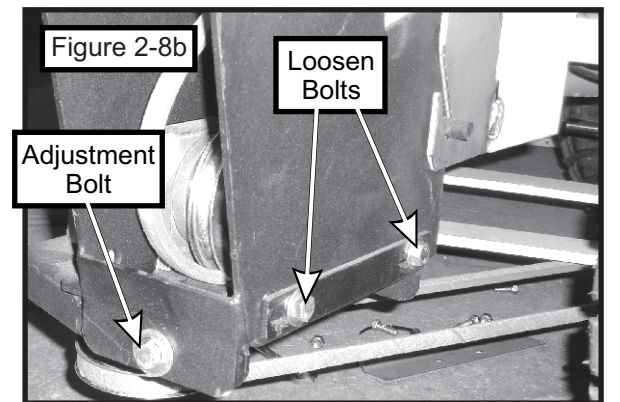
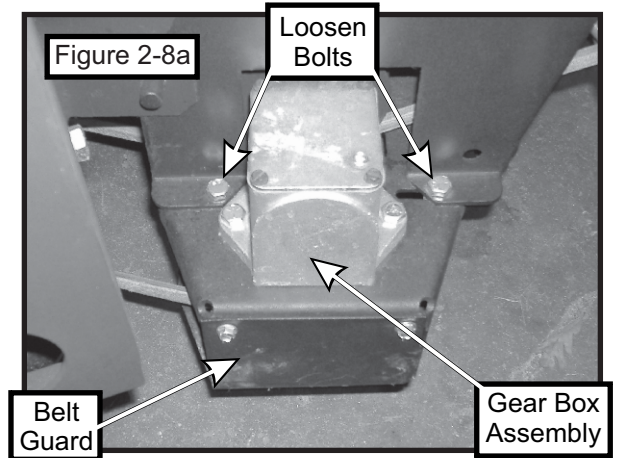

2-9 Cam Assembly Adjustment

The cam assembly P#(A0422), which controls the blower belt tension, comes from the factory pre-adjusted. If the belt is too tight or becomes too loose, remove the hair pin clip P#(K0130) from the belt tension rod P#(K0326) and pull the "L" end of the rod out of it's hole in the cam assembly. The tension rod may then be screwed out to tighten the belt or screwed in to loosen the belt. Replace the "L" end into the top hole in the cam and replace the hair pin clip. Adjust the cam stop bolt P#(K1159) to allow the cam to rotate slightly over center when the blower is engaged (Figure 2-9).

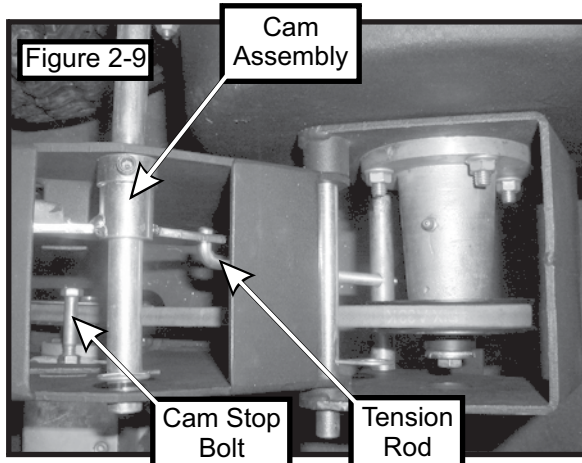

2-10 Upper Frame Assembly Installation

NOTE: During this step, it is suggested that two people install the upper frame to the lower mount tube.

Using (2) people to lift the upper frame assembly P#(A0585), lift the upper frame above the lower mount assembly P#(A0706) making sure the frame is pointing away from the mower (Figure 2-8). Slide the upper frame tube into the lower mount assembly and align the mounting hole. Insert (1) 1/2" x 2-1/2" clevis pin P#(K0133) through the hole and fasten with (1) 5/32" x 2-5/8" hair pin clip P#(K0088).

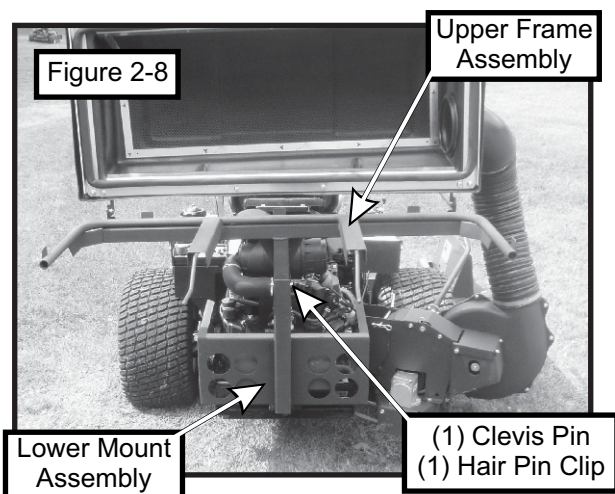

2-11 Top Assembly To Upper Frame Assembly Installation

Align the pivot brackets of the top assembly P#(A0585) to the pivot point on either side of the upper frame assembly. Place (1) P#(K0041) fender washer between each pivot point (Figure 2-7) and fasten each side by using (1) P#(K1153) 5/16"-18 x 3/4" HHCS and (1) P#(K1180) 5/16"-18 nyloc nut. When fastening leave nut slightly loose so that the top can pivot freely.

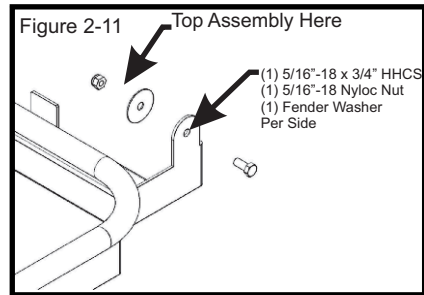

2-12 Boot To Mower Deck Installation

Remove the grass deflector and hardware from the mower deck.

60" DECK INSTRUCTIONS

Attach the boot plate P#(B0628) to the boot P#(E1902) using (2) 3/8"-16 x 1" carriage bolt P#(K1182), (2) 3/8" flat washer P#(K0047) and (2) 3/8"-16 nylon flange lock nut P#(K2038). Secure the boot plate to the mower deck using (1) boot rod P#(B0348). Secure the boot rod with (1) hair pin clip P#(K0099). Refer to Figure 2-12a.

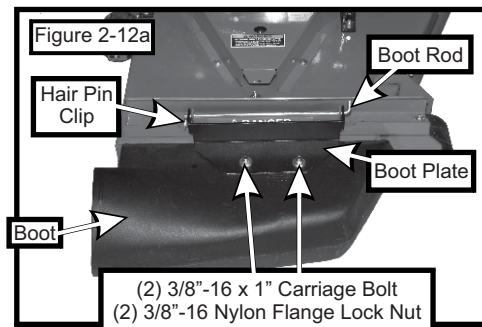

52" DECK INSTRUCTIONS

Attach the boot plate P#(B0628) to the boot P#(E1902) using (2) 3/8"-16 x 1" carriage bolt P#(K1182), (2) 3/8" flat washer P#(K0047) and (2) 3/8"-16 nylon flange lock nut P#(K2038). Secure the boot plate to the mower deck using (1) boot rod P#(B0348) and (2) spacers P#(B3143). Secure the boot rod with (1) hair pin clip P#(K0099). Refer to Figure 2-12b.

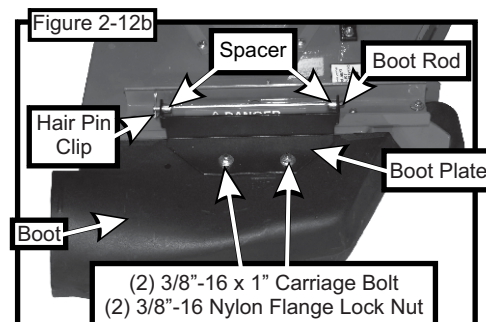

2-13 Blower Cone Installation

Thread (1) 5/16"-18 jam nut P#(K0120) onto each end of (2) 5/16"-18 x 2-1/2" HHCS P#(K0125). Now partially thread the bolts into each of the two tabs located on the blower housing. Place blower cone so the two tabs line up with the bolts then tighten completely. Refer to Figure 2-13 for reference.

Figure 2-13

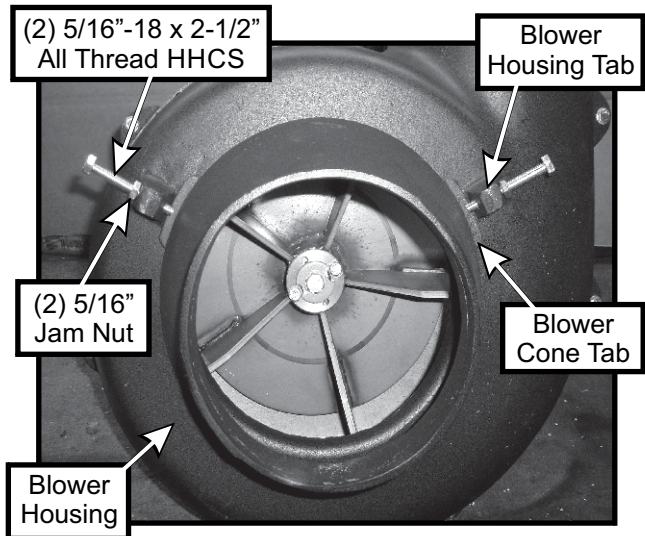

2-14 Impeller Blade Removal/Replacement

To Remove: First remove the 3/8"-16 x 1-1/2" HHCS P#(K1211) (#1), taper lock bushing washer P#(K0278) (#3) and spacer bushing P#(S3242) (#4) from the taper lock bushing (#5). See Figure 2-14. Next remove the (2) 1/4"-20 x 1" HHCS (#2) and place them into the threaded holes of the taper-lock bushing P#(S4302) (#5). Gradually thread each bolt evenly into the taper-lock bushing, forcing the blade to break-away from the taper-lock bushing. If the impeller will not move, carefully hit the base of the impeller, between each vein, with a hammer, then try again.

To Replace: Place impeller blade over the engine shaft. Slide the taper-lock bushing (#5) on to the engine shaft and into the impeller blade, aligning the **non-threaded** holes of the taper-lock bushing to the threaded holes of the impeller blade. Fasten by using (2) 1/4"-20 x 1" HHCS (#2), (1) spacer bushing (#4) (1) taper lock bushing washer (#3), and (1) 3/8"-16 x 1-1/2" HHCS (#1). Torque to the proper specifications in the torque chart on the back of this manual. Next, rotate the impeller blade to ensure that the blade is clear of contact on all sides of the blower housing.

Figure 2-14



2-15 Length Of Hose Adjustment

The hoses in steps 2-16 and 2-17 must be cut to fit your machine. Follow steps 2-16 and 2-17. do not cut the hoses until you have tried to fit them on your machine. Remember that the hoses have to be long enough to adjust for the blower assembly's movement as well as allow for enough clamping surface between the inlet, blower assembly, and the deck boot.

2-16 Upper Hose Installation

Fasten the inlet to the plastic top by sliding the inlet from the inside of the top to the outside and lock into place. Slide a hose clamp P#(J0060) onto both ends of the 6" upper hose. Then slide one end of the 6" hose onto the inlet. Make sure there is about a two-inch overlap between the hose end and the container inlet. Proceed to slide the opposite end of the 6" hose onto the outlet of the blower assembly. Make sure both ends of the hose are clearly attached to the inlet and the blower assembly inlet. Tighten the hose clamps.

2-17 Lower Hose To Blower Cone Installation

Slide a hose clamp P#(J0080) over both ends of the lower hose. Then proceed to slide the lower hose onto the blower cone. Tighten the hose clamp. Refer to Figure 2-17.

Figure 2-17

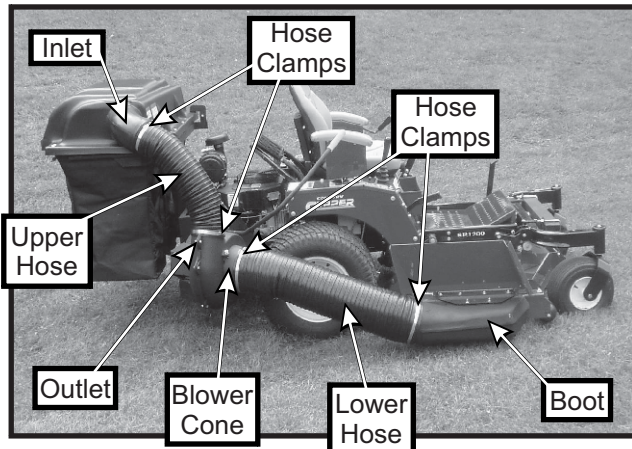

2-18 Lower Hose To Boot Installation

Take the unattached end of the lower hose and slide it over the circular end of the boot. Use the lower hose clamp to secure the hose to the boot (Figure 2-18). Tip: Before securing clamp rotate hose counter-clockwise (away from yourself) approximately 1" to add in retaining boot to mower deck.

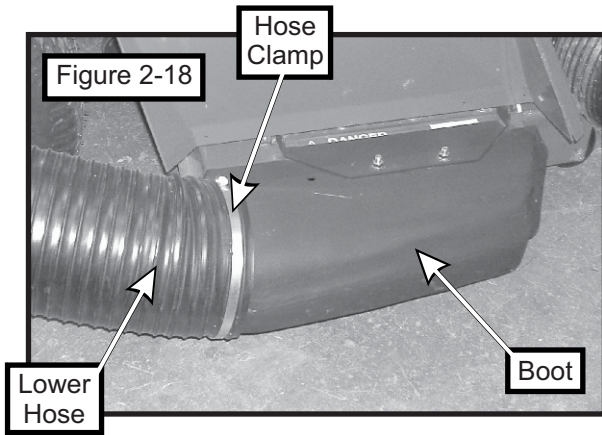

2-19 Front Weight Installation

Before installing the weight kit, remove the deck step and hardware shown in Figure 2-19a. Fasten the weight brackets P#(B0418) and the weight mount plates P#(B0419) to the front casters using (4) 3/8"-16 x 3" carriage bolts P#(K1187) and (4) 3/8"-16 nyloc nuts P#(K1216). Tighten bolts only finger tight at this point. Insert (3) weight assemblies P#(A0852) into the weight mount brackets. Secure the weight assemblies using (2) 3/8" x 6-1/8" clevis pins P#(K1624) and (2) hair pin clips P#(K0086). See Figure 2-19b for reference.

Figure 2-19a

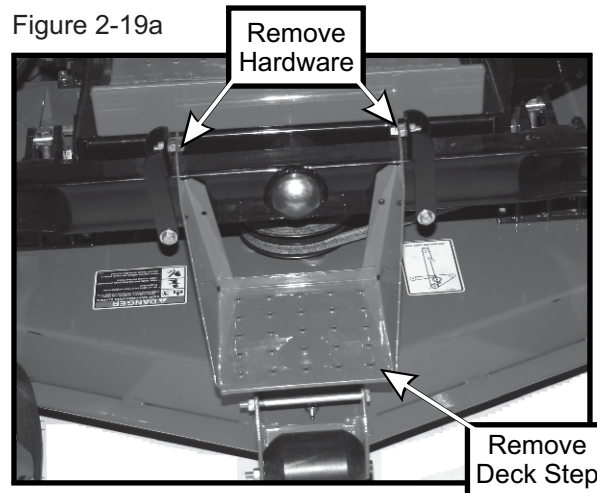
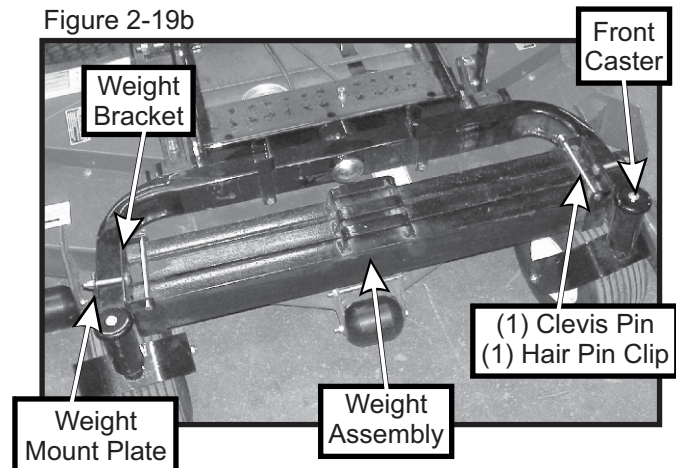
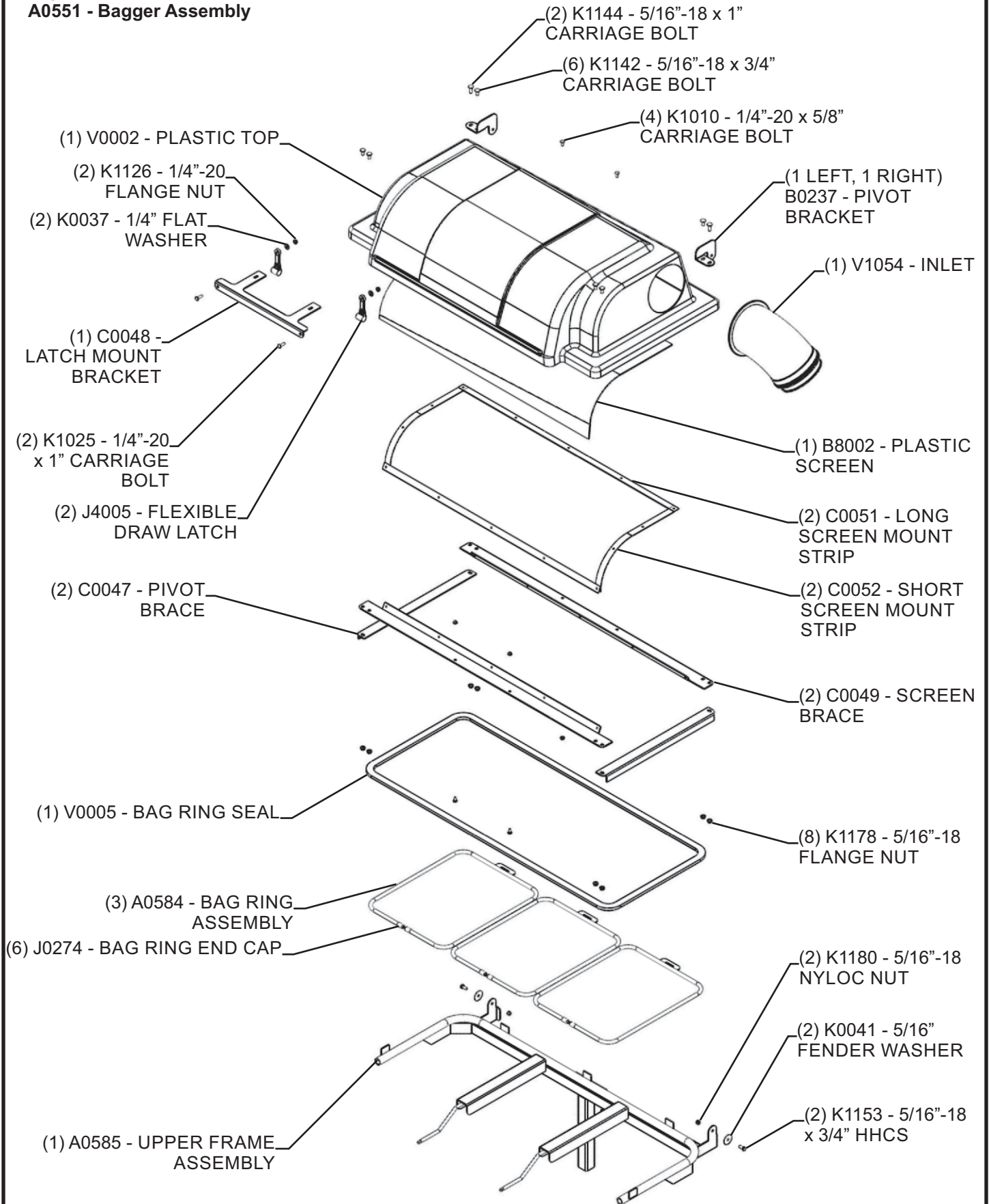

Figure 2-19b



**Exploded View Of The
A0551 - Bagger Assembly**



MODEL#: 49131503

MOWER NAME: COUNTRY CLIPPER

MOWER MODEL: BOSS SR1220 & CHARGER SR1025

MOWER DECK SIZE: 52" & 60"

VAC NAME: 13 CUBIC FOOT PRO BAGGER

PTO DRIVEN

SHIVERS PART#: 629FS-001A

PROFESSIONAL BAGGING SYSTEM

FOR YEAR: 2012-2011

REVISED: 12/19/2013

A1136 UNIT ASSEMBLY

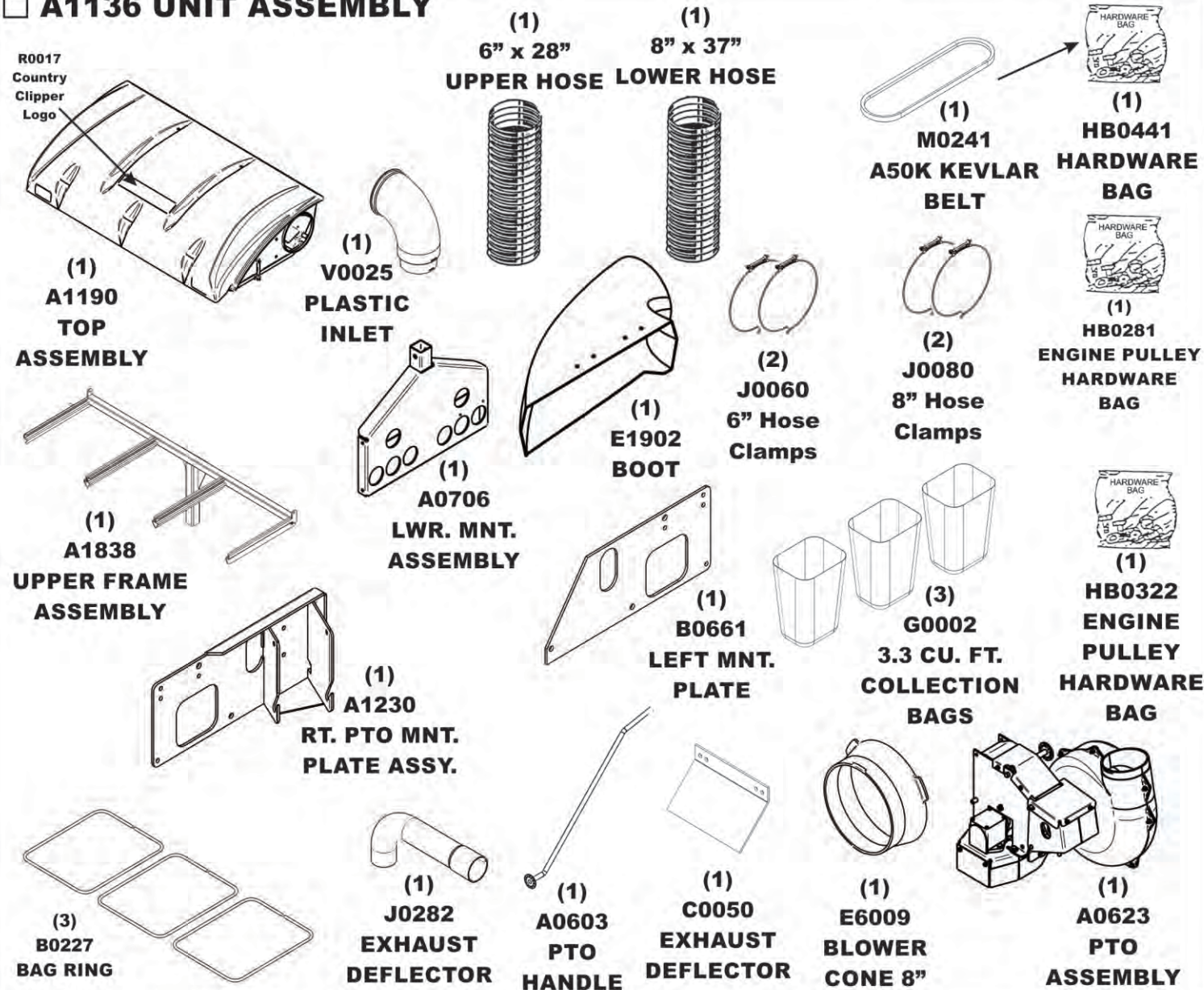

A0854 WEIGHT KIT

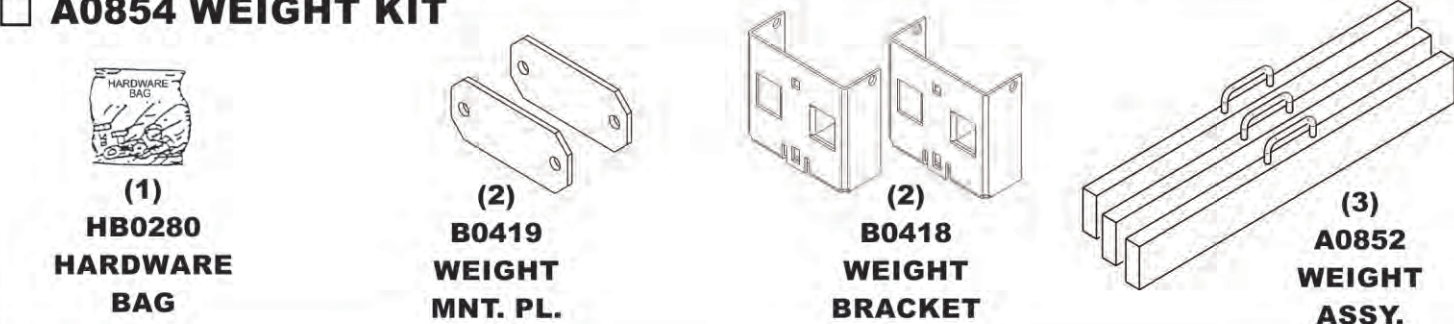

Item Number	Document Number	Title	Quantity
1	A0429	GEAR BOX ASSEMBLY	1
2	K0348	3/8"-16 x 2" ALL THREAD HHCS	1
3	K0047	3/8" FLAT WASHER 1.00 OD x .446 ID x .075 T	5
4	K0353	1/4"-20 x 1/2" HHSTS	7
5	K1159	5/16"-18 x 2" ALL THREAD HHCS	1
6	K1178	5/16"-18 FLANGE NUT	1
7	A0144	BLOWER MOUNT BRACKET ASSEMBLY	1
8	B1755	BLOWER PIVOT ROD	1
9	K0086	.125 OD x 2.50 HAIR PIN CLIP	2
10	B0121	BLOWER BELT GUARD	1
11	A0604	PTO HANDLE MOUNT ASSY	1
12	A0422	CAM BRACKET ASSEMBLY	1
13	K0356	3/8"-16 TAPERED SET SCREW	1
14	K0326	BELT TENSION ROD 3/8"-16	1
15	K0130	.091 OD x 1.625 L HAIR PIN CLIP	1
16	E0121	PTO SHAFT HOUSING	1
17	N0147	BEARING 2.0472 OD, 0.9843 ID, 0.5906 W (6205RS PEER)	1
18	N0148	BEARING 1.625 OD, 0.75 ID, 0.4375 W (9R12 PEER)	1
19	B1758	PTO SHAFT	1
20	J0801	1/4"-28 ZIRC FITTING	1
21	J0254	3/16" SQ. x 3/4" LONG KEYWAY	1
22	M0228	BLOWER PULLEY	1
23	K1446	1.187 OD x .380 ID x .187 WASHER	1
24	K1190	3/8"-16 x 3/4" HHCS	1
25	E4004B	BLOWER HSG. BACK	1
26	E4004F	BLOWER HSG. FRONT	1
27	K1125	1/4"-20 X 1" HHCS	6
28	K1126	1/4"-20 FLANGE NUT	5
29	K1193	3/8"-16 x 1-1/2" HHCS	4
30	K1215	3/8"-16 FLANGE NUT	12
31	A0645	SMALL 4-BLADE IMPELLER	1
32	S4302	TAPER-LOCK BUSHING	1
33	S3242	PLATED BUSHING	1
34	K1225	1/4"-20 X 1" HHCS GRADE 8	2
35	K0278	TAPER-LOCK BUSHING WASHER	1
36	K1211	3/8"-16 x 1-1/2" HHCS GRADE 8	1
37	B0269	GEAR BOX PULLEY GUARD	1
38	B0270	PTO ARM GUARD	1
39	A0622	PTO ARM ASSY.	1
40	A0624	BASE PLATE ASSY.	1
41	K1191	3/8"-16 x 1" HHCS	6
42	K1197	3/8"-16 X 2 1/2" HHCS	1
43	M0250	A30K KEVLAR BELT	1
44	M0241	A50K KEVLAR BELT	1

2-20 Installation/Removal Of Collection Bags

To install the bag onto the bag ring, first make sure the bag ring end caps are fastened to the bag ring. Place the seam openings of the bag onto the bag ring openings and turn the bag until the slot bracket in the bag ring is protruding from the opening in the bag (Figure 2-20a). Do this for each of three bags.

Install the completed assemblies onto the support frame and close the plastic top. Fasten both draw latches to hold the plastic top closed (Figure 2-20b).

To empty the bag, remove the bag and bag ring by lifting and sliding rearward. Grasp the loop on the bottom of the bag, turn it upside down and empty the collected debris (Figure 2-20c). Repeat for the other bags. Reinstall all bags, line with plastic bags if desired, close the plastic top and reattach the draw latches.

Plastic lawn and leaf bags, 33 gallon size, may be used inside the cloth bags. Be sure to leave enough plastic bag hanging over the frame so the plastic bags can be twist tied before emptying (Figure 2-20d).

Figure 2-20b

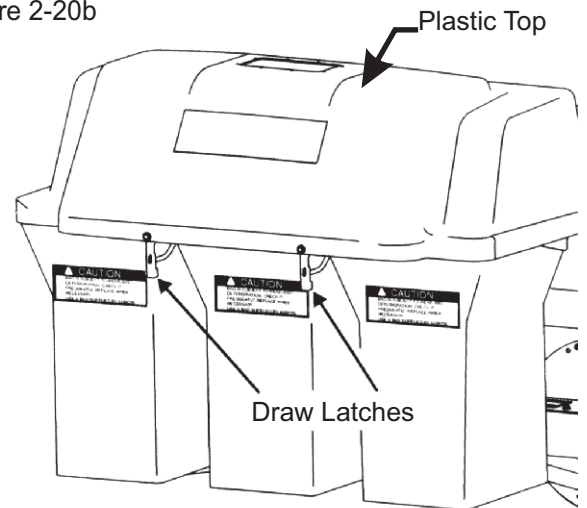

Figure 2-20c

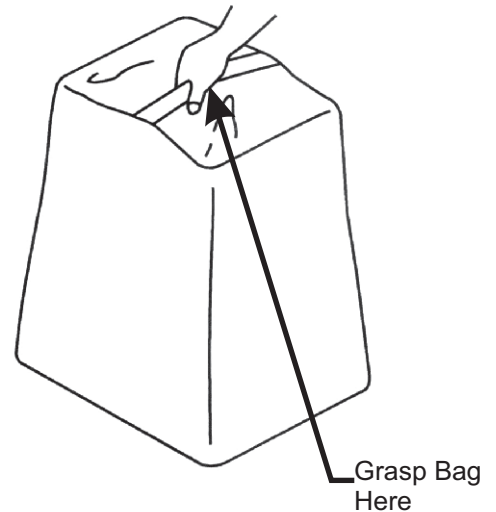

Figure 2-20d

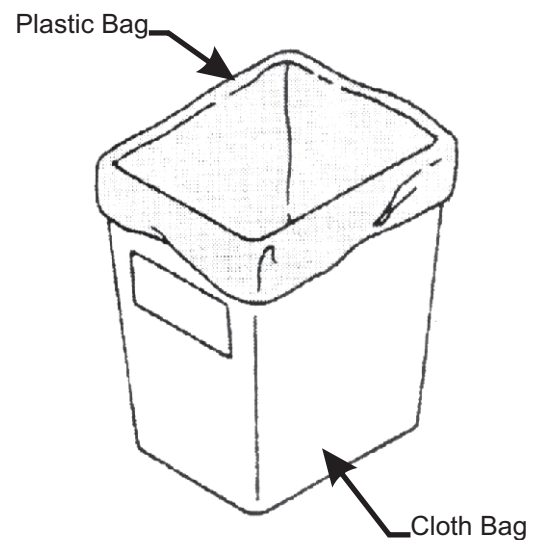
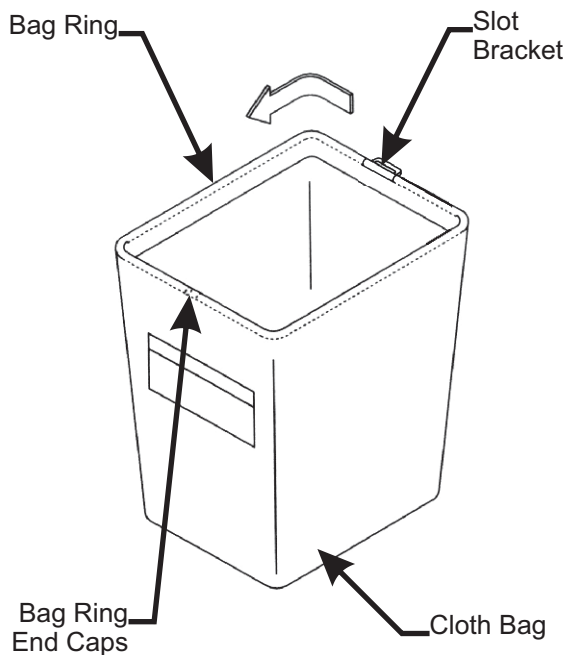

Figure 2-20a



SECTION III OPERATING INSTRUCTIONS

3-1 General Safety

Only qualified people familiar with this operator's manual and the mower's operator's manual should operate this machine.

3-2 Operation And Tips On Mowing

- A. Perform BEFORE EACH USE the maintenance list in paragraph 4-1.
- B. Start mower.
- C. With the mower at high idle speed, engage the mower deck.
- D. While seated in the operator's seat, rotate the engagement handle of the collection system away from the mower. Continue to rotate the handle until it stops in an over center position. With the blower engaged, you can proceed to operate the control levers of the mower.

NOTE: If the collection system does not appear to be collecting the grass clippings, disengage the deck and blower, then, engage the parking brake and turn the mower off. Proceed to section 3-3, and review the section 2-3 and 2-4, in this manual.

To obtain the maximum effectiveness from your collection system the tips listed below should be followed:

- * Watch your speed- Normal conditions will allow a speed of up to approximately 5 mph, but thick, heavy damp conditions will require reduced ground speed.
- * Mow with sharp blades- A sharp blade cuts cleaner.
- * Wet grass and leaves will decrease effectiveness and will increase horsepower requirements.
- * Mow at higher cutting heights- Remove and mulch no more than 2" of grass length with each mowing. (Experts recommend not cutting off more than 1/3 of the grass blade length at any given time.)
- * Mow twice, at different height settings, (high, then low), if grass is extra tall.
- * Remember that horsepower requirements will vary with the mowing conditions such as type and height of turf grass, moisture content, amount of leaves, whether the terrain is flat or hilly, etc.

3-3 Disengagement Of The Blower

- A. To disengage the blower, rotate the engagement handle towards the mower.

WARNING: The blower will continue to spin. DO NOT TOUCH the blower, pulleys, or the belt until the tractor is turned off. DO NOT adjust the belt tension until the mower is turned off. Refer to section 2-9 of the manual.

3-4 Unloading The Collection System

NOTE: To determine when the collection bags are full, follow the following steps:

- A. Stop the forward movement of the mower.
- B. Disengage the mower deck.
- C. Disengage the blower.
- D. Engage the parking brake.
- E. Once the parking brake has been engaged, then and only then, walk behind the mower and check the collection bags by lifting the plastic hood. Load in bags should not exceed the height of the installed bag.
- F. To release bags from frame, lift bag ring from tab on bagger frame, slide bag out and turn bags over to deposit clippings.
- G. Follow steps on page 15 to re-attach bags back to the bagger.

NOTE: Do not allow collection bags to become over-filled as potential damage may occur to your equipment. Also, be sure to clean the hood screen as needed.

SECTION IV MAINTENANCE

4-1 Maintenance Checklist

NOTE: REMOVE PTO ASSEMBLY BEFORE RAISING DECK FOR MAINTENANCE.

Before each use:

1. Check blades and spindles to be sure that no foreign objects, such as wire or steel strapping bands, are wrapped around them.
2. Inspect blades for wear. Replace if necessary. If it is necessary to sharpen the blades, remove the blades from the spindles before sharpening. DO NOT sharpen blades while still attached to the mower.

3. Make sure all shields are in place and in good condition. Repair or replace any missing or damaged shields.
4. Perform lubrication per paragraph 4-2.
5. Listen for abnormal sounds, which might indicate loose parts, damaged bearings, or other damage. Correct any deficiency before continuing operation.
6. With the engine off, engage the blower assembly. Check the belt tension and inspect the pulley belt for cracks or tears.
7. Check for wear or deterioration of the upper or lower hoses. If there are any portions of the hose that have been torn or worn through, replace immediately.

After Each Use:

1. Clean all debris from machine especially from the container, underneath the belt shields, and safety decals. Replace any missing or illegible decals.
2. Inspect the unit for worn or damaged components. Repair or replace before the next use. Any replacement component installed during repair shall include the component's current safety decal specified by the manufacturers to be affixed to the component.
3. Check belt for proper tension.

THE SERIAL NUMBER PLATE
IS LOCATED ON THE TOP
ASSEMBLY P#(A0551)
(SEE PAGE 13 FOR REFERENCE)



WRITE THE MODEL AND
SERIAL NUMBER IN THE
BOX TO THE LEFT
FOR FUTURE REFERENCE.

4-2 Lubrication

NOTE: Use only white lithium based grease for lubrication of the shaft on the blower assembly.

1. On initial use: Grease the fitting on the blower shaft.
2. Every 25 hours of use: Re-grease the grease fitting.
3. Every 200 hours of use: Check oil levels in gear box. Oil in gear box should cover the gears. If not, fill using an EP90 weight oil. 6oz. will fill the gear box from empty.

SECTION V PARTS AND SERVICE

5-1 Parts And Service Information

Collection system owners should record the name and telephone number of their Service Center. Your Service Center will be happy to supply replacement parts, accessories, and do any service or repairs to your collection system. If for any reason your Service Center is unable to service your collection system or supply replacement parts, contact Country Clipper and include the following information on the chart below.

Unit Model Number: _____

Unit Engine Size: _____

Unit Serial Number: _____

Date of purchase: ____/____/____

Dealer/Distributor Name: _____

Address: _____ **State:** _____ **Zip:** _____

Phone Number: _____

Country Clipper Division of Shivers Mfg. Inc

613 W. English | Corydon, IA | 50060

Phone: 1-800-344-8237 | 641-872-2544

Fax: 641-872-1593

E-Mail: countryclipper@countryclipper.com

SAFETY DECALS

To promote safe operation, Country Clipper supplies safety decals on all products manufactured. Damage can occur to safety decals either through shipment, use or reconditioning. Contact your local Service Center for replacement decals.



Part #: R1069
Warning: Turn Off Blower Label

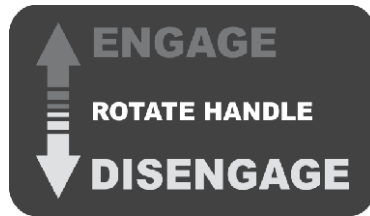

Part #: R1083
Engage/Disengage Label



Part #: R1057
Red Reflector Label



Part #: R1052
Small Warning: Turn Off Blower Label



Part #: R1054
Important Label



Part #: R4037
Warning: Hot Surface Label



Part #: R1051
Warning: Hearing Protection Label



Part #: R1065
Made In America Label



Part #: R4015
Danger: Rotating Blade Label

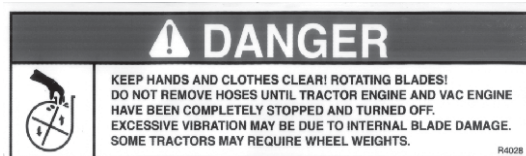

Part #: R4028
Danger Keep Hands & Clothes Clear Label



Part #: R4008
Caution: Rotating Blades Label

TORQUE SPECIFICATIONS

AMERICAN Bolt Head Markings

Recommended Torque in Foot Pounds (Newton Meters).*

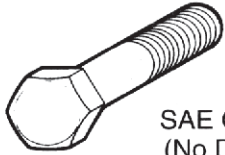

SAE Grade 2
(No Dashes)

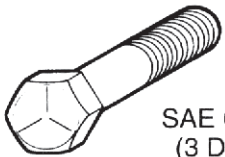

SAE Grade 5
(3 Dashes)

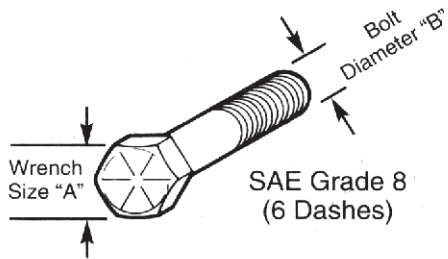

SAE Grade 8
(6 Dashes)

WRENCH SIZE (IN.) "A"	BOLT DIAMETER (IN.) "B" AND THREAD SIZE	SAE GRADE 2	SAE GRADE 5	SAE GRADE 8
7/16	1/4 - 20 UNC	6 (7)	8 (11)	12 (16)
7/16	1/4 - 28 UNF	6 (8)	10 (13)	14 (18)
1/2	5/16 - 18 UNC	11 (15)	17 (23)	25 (33)
1/2	5/16 - 24 UNF	13 (17)	19 (26)	27 (37)
9/16	3/8 - 16 UNC	20 (27)	31 (42)	44 (60)
9/16	3/8 - 24 UNF	23 (31)	35 (47)	49 (66)
5/8	7/16 - 14 UNC	32 (43)	49 (66)	70 (95)
5/8	7/16 - 20 UNF	36 (49)	55 (75)	78 (106)
3/4	1/2 - 13 UNC	49 (66)	76 (103)	106 (144)
3/4	1/2 - 20 UNF	55 (75)	85 (115)	120 (163)
7/8	9/16 - 12 UNC	70 (95)	109 (148)	153 (207)
7/8	9/16 - 18 UNF	79 (107)	122 (165)	172 (233)
15/16	5/8 - 11 UNC	97 (131)	150 (203)	212 (287)
15/16	5/8 - 18 UNF	110 (149)	170 (230)	240 (325)
1-1/8	3/4 - 10 UNC	144 (195)	266 (360)	376 (509)
1-1/8	3/4 - 16 UNF	192 (260)	297 (402)	420 (569)
1-5/16	7/8 - 9 UNC	166 (225)	430 (583)	606 (821)
1-5/16	7/8 - 14 UNF	184 (249)	474 (642)	668 (905)
1-1/2	1 - 8 UNC	250 (339)	644 (873)	909 (1232)
1-1/2	1 - 12 UNF	274 (371)	705 (955)	995 (1348)
1-1/2	1 - 14 UNF	280 (379)	721 (977)	1019 (1381)
1-11/16	1-1/8 - 7 UNC	354 (480)	795 (1077)	1288(1745)
1-11/16	1-1/8 - 12 UNF	397 (538)	890 (1206)	1444 (1957)
1-7/8	1-1/4 - 7 UNC	500 (678)	1120 (1518)	1817 (2462)
1-7/8	1-1/4 - 12 UNF	553 (749)	1241 (1682)	2013 (2728)
2-1/16	1-3/8 - 6 UNC	655 (887)	1470 (1992)	2382 (3228)
2-1/16	1-3/8 - 12 UNF	746 (1011)	1672 (2266)	2712 (3675)
2-1/4	1-1/2 - 6 UNC	870 (1179)	1950 (2642)	3161 (4283)
2-1/4	1-1/2 - 12 UNF	979 (1327)	2194 (2973)	3557 (4820)

METRIC

Recommended torque in foot pounds (newton Meters).*

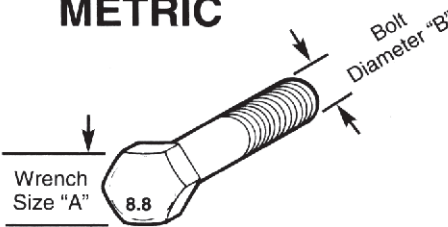

Numbers appearing on bolt heads indicate ASTM class.

WRENCH SIZE (mm) "A"	BOLT DIA. (mm) "B"	ASTM 4.6	ASTM 8.8	ASTM 9.8	ASTM 10.9
8	5	1.8 (2.4)		5.1 (6.9)	6.5 (8.8)
10	6	3 (4)		8.7 (12)	11.1 (15)
13	8	7.3 (10)		21.1 (29)	27 (37)
16	10	14.5 (20)		42 (57)	53 (72)
18	12	25 (34)	74 (100)	73 (99)	93 (126)
21	14	40 (54)	118 (160)	116 (157)	148 (201)
24	16	62 (84)	167 (226)	181 (245)	230 (312)
30	20	122 (165)	325 (440)		449 (608)
33	22		443 (600)		611 (828)
36	24	211 (286)	563 (763)		778 (1054)
41	27		821 (1112)		1138 (1542)
46	30	418 (566)	1119 (1516)		1547 (2096)

*Use 75% of the specified torque value for plated fasteners. Use 85% of the specified torque values for lubricated fasteners.



Country Clipper Division of Shivers Mfg. Inc
613 W. English | Corydon, IA | 50060
Phone: 1-800-344-8237 | 641-872-2544
Fax: 641-872-1593
E-Mail: countryclipper@countryclipper.com