



PTO GRASS COLLECTION SYSTEM

DESIGNED FOR:
**CUB CADET
COMMERCIAL**

2009-2011 MODEL YEAR (TANK L48, L60) (TANK M48, M54, M60)

MODEL# 21131506



OPERATOR'S MANUAL

ASSEMBLY • OPERATION • MAINTENANCE

PECO GRASS COLLECTION SYSTEM

TABLE OF CONTENTS

| SECTION | PAGE | SECTION | PAGE |
|---|-------|--|-------|
| Safety | 2 | 2-14 Blower Cone Installation | 12 |
| Safety Alert Symbols | 3 | 2-15 Length Of Hose Adjustment | 12 |
| Warranty | 4 | 2-16 Upper Hose Installation | 12 |
| I INTRODUCTION AND DESCRIPTION | 5 | 2-17 Lower Hose To Blower Cone Installation | 12 |
| 1-1 Introduction | 5 | 2-18 Lower Hose To Boot Installation | 12 |
| 1-2 Description | 5 | 2-19 Front Weight Installation | 13 |
| II INSTALLATION FOR USE | 5 | 2-20 Impeller Blade Removal/Replacement | 13 |
| 2-1 Preparation Of Mower | 5-6 | 2-21 Installation/Removal of Collection Bags | 14 |
| 2-2 Exhaust Deflector Installation | 6 | Exploded Part Views and Assemblies | 15-18 |
| 2-3 Left Lower Mount Plate and PTO Mount Plate Assembly Installation | 6 | Safety Interlock Harness Wiring Diagram | 19 |
| 2-4 Frame Bracket Extender Installation | 6 | III OPERATING INSTRUCTIONS | 20 |
| 2-5 Lower Mount Assembly installation | 6 | 3-1 General Safety | 20 |
| 2-6 PTO Assembly Installation | 6-7 | 3-2 Operation & Tips On Mowing | 20 |
| 2-7 Belt Installation And Adjustment | 7 | 3-3 Disengagement Of The Blower | 20 |
| 2-8 Cam Assembly Adjustment | 7 | 3-4 Unloading The Collection System | 20 |
| 2-9 Safety Interlock Harness Installation | 8 | IV MAINTENANCE | 20 |
| 2-10 Upper Frame Assembly Installation | 9 | 4-1 Maintenance Checklist | 20 |
| 2-11 Top Assembly To Upper Frame Assembly Installation | 9 | 4-2 Lubrication | 21 |
| 2-12 Deck Baffle Installation | 9 | V PARTS AND SERVICE | 21 |
| 2-13 Boot To Mower Deck Installation | 10-11 | 5-1 Parts And Service Information | 21 |
| | | Safety Decals | 22 |
| | | Torque Specifications | 23 |

Safety

1. Read the operator's manual carefully and familiarize yourself with the proper use of your attachment. Do not allow anyone who is not acquainted with the Safety Instructions to use your attachment.
2. Know the controls and how to stop quickly. **READ THE OPERATOR'S MANUAL!**
3. Do not allow children to operate the vehicle. Do not allow adults to operate it without proper instruction.
4. Be especially watchful of children and pets darting into the area while operating.
5. Keep your eyes and mind on your unit while mowing or operating your attachment. Don't let others distract you.
6. Do not attempt to operate your unit or mower when not in the driver's seat.
7. Always stop unit when emptying the container.
8. Stop unit, shut off deck attachment, set parking brake, shut off mower engine and remove spark plug wire before removing clogs, removing or replacing hose, boot, blower cone, or performing any maintenance.
9. Mow across the face of slopes (not steeper than 10 degrees); never up and down the face of the slope.
10. It is recommended that the container be kept only half full when negotiating any slopes. Start mowing on slopes when the container is empty.
11. Inspect your lawn and remove any foreign objects before mowing. Never deliberately run the mower across any foreign object.
12. Wear ear protection if the noise level is offensive.
13. Wear eye protection to prevent debris from damaging your eyes.

SAFETY

WARNING! NEVER operate the mower unless the discharge guard and either the deflector assembly or the vacuum collector adapter are fastened securely in place.

WARNING! Do not work around the mower deck boot or the blower area until you are certain that the mower blades and the blower impeller have stopped rotating.

WARNING! To avoid serious injury, perform maintenance on the vacuum collector; **ONLY AFTER STOPPING THE MOWER'S ENGINE AND WAITING FOR ALL MOVING PARTS TO COME TO A COMPLETE STOP.** Set the parking brake. Always remove the ignition key before beginning maintenance.

WARNING! For your own personal safety, **ALWAYS** mow **ACROSS** the face of slopes and **NEVER UP and DOWN** the face. **NEVER** attempt to mow excessively steep slopes, and use caution when turning on any slope.

Safety Alert Symbol



This Safety Alert Symbol means: **“ATTENTION! BECOME ALERT! YOUR SAFETY IS INVOLVED!”**

This symbol is used to call attention to safety precautions that should be followed by the operator to avoid accidents. When you see this symbol, carefully read the message that follows and heed its advice. Failure to comply with safety precautions could result in death or serious bodily injury.

Safety Signs

The signal words **DANGER**, **WARNING**, and **CAUTION** are used on the equipment safety signs. These words are intended to alert the viewer to the existence and the degree of hazard seriousness.



White letters on **RED**

This signal word indicates a potentially hazardous situation which, if not avoided, will result in death or serious injury.



Black letters on **ORANGE**

This signal word indicates a potentially hazardous situation which, if not avoided, could result in death or serious injury.

It may also be used to alert against unsafe practices.



Black letters on **YELLOW**

This signal word indicates a potentially hazardous situation exist which, if not avoided, will result in minor or moderate injury.

It may also be used to alert against unsafe practices.

PECO LIMITED WARRANTY FOR NEW PRODUCTS

A. WHAT IS UNDER WARRANTY?

PECO extends the following warranties to the original purchaser of each new PECO consumer product subject to the following limitations.

1. PRODUCT WARRANTY: Any part of any consumer product, which is defective in material or workmanship as delivered to the purchaser will be repaired or replaced, as PECO elects, without charge for parts or labor, if the defect appears within 12 months from the date of delivery of the product to the original purchaser.

ALL DEFECTIVE PARTS MUST BE RETURNED TO PECO FOR INSPECTION TO DETERMINE VALIDITY OF WARRANTY CLAIMS. Freight and mailing will be borne by the customer.

2. PARTS REPLACED DURING WARRANTY: Any new PECO part which is furnished in performance of this warranty and is defective in material or workmanship as delivered to the purchaser will be repaired or replaced, as PECO elects, without charge if the defect appears within 90 days from the date of installation of such part or before the expiration of the original warranty period, whichever is later.

B. SECURING WARRANTY ADJUSTMENTS.

Call PECO for Return Authorization. Damaged or broken parts other than engines or batteries, must be returned to New PECO, Inc. 100 Airport Road, Arden, NC 28704 before any warranty adjustment can be authorized. At the time of requesting warranty adjustment, the purchaser must present evidence of the date of delivery of the product. The purchaser shall pay any charge for the product to and from Arden, NC.

C. ITEMS NOT COVERED BY PECO WARRANTY.

Engines and batteries attached to PECO products are covered under a separate warranty by the respective manufacturer.

D. UNAPPROVED ALTERATION OR MODIFICATION.

All obligations of New PECO, Inc. under this warranty shall be terminated if products are altered or modified in ways not approved by New PECO, Inc.

E. ACCIDENTS AND NORMAL MAINTENANCE.

The warranty covers only defective material and workmanship. It does not cover depreciation or damage caused by normal wear, accident, improper use or abuse of products. The cost of normal maintenance and normal replacement of service items such as belts, cutting blades, hoses, etc., which are not defective shall be paid for by the purchaser.

F. NO REPRESENTATIONS ADDITIONAL WARRANTIES, DISCLAIMER.

Neither New PECO, Inc. nor any company affiliated with it makes any warranties, representations or promises as to the quality of performance of its products other than those set forth herein. Except as described above, New PECO, Inc. makes no other warranties **AND SPECIFICALLY DISCLAIMS ANY AND ALL IMPLIED WARRANTIES OF FITNESS AND MERCHANTABILITY.**

G. ANY MACHINE USED FOR RENTAL PURPOSES ARE GUARANTEED FOR 45 DAYS FROM DATE OF ORIGINAL SALE ONLY.

H. REMEDIED EXCLUSIVE.

The only remedies the purchaser has in connection with the breach or performance of any warranty on New PECO, Inc. consumer products are set forth above. In no event will PECO be liable for special incidental or consequential damages.

1. NO SERVICE CENTER WARRANTY.

The selling Service Center makes no warranty on his own on any item warranted by New PECO, Inc. unless he delivers to purchaser a separate written warranty certificate specifically warranting the item. The dealer has no authority to make any representation or promise on behalf of PECO or to modify the terms of this warranty in any way.

Section I

INTRODUCTION & DESCRIPTION

1-1 Introduction

We are pleased to have you as a PECO customer. Your collection system has been designed to give you a low maintenance, simple, and effective way to collect the grass clippings from your mower. This manual is provided to give you the necessary instructions to properly mount and operate the collection system on your mower. Please read this manual thoroughly. Understand what each control is for and how to use it. Observe all safety decal precautions on the machine and noted throughout the manual.

NOTE: all references made to right, left, front, rear, top or bottom are as viewed from the normal operator's position on the mower.

1-2 Description

The grass collection system is designed for turf maintenance where there is a need to collect the grass clippings as the mower cuts the turf. It is also used for picking up leaves and twigs in pre-season and post-season clean-up. The blower, mounted on the right side of the unit, uses a belt and gearbox system from the engine PTO shaft. Drive train protection comes through belt slippage. The blower draws grass clippings from the discharge area of the cutter deck back to the (3) - 4 cubic foot collection bags P#(G0003) at the rear portion of the mower frame. The operator can engage the blower with a push of the over-center linkage on the right side of the unit. Once the bags are full with clippings, they can be released to make for easy dumping.

Section II

INSTALLATION FOR USE

2-1 Preparation Of Mower

From the underside of the engine, disconnect the wiring harness attached to the electric clutch. Remove the bolt and electric clutch from the mower. Refer to Figure 2-1a.

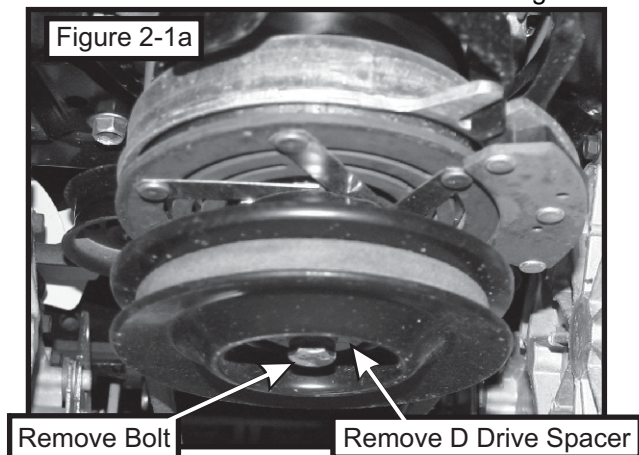

Remove the D-drive spacer using an arbor press or equivalent. On removal, adjacent bearing OUTER race must be supported or bearing damage may occur. Refer to Figure 2-1b.

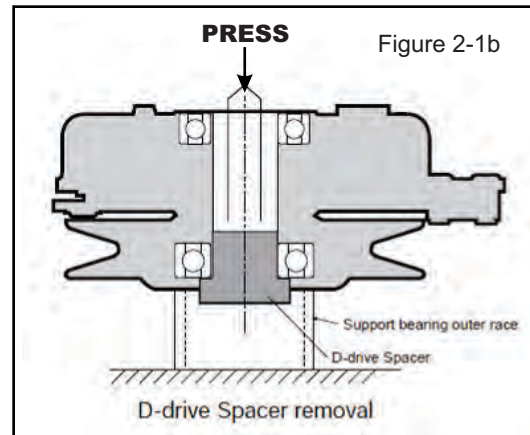

The engine pulley assembly must be installed using an arbor press or equivalent. Upon Installation, opposite bearing inner race must be supported or bearing damage may occur. Refer to Figure 2-1c.

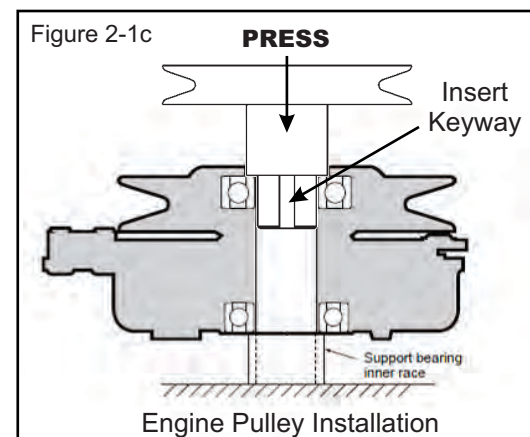

Fasten engine pulley assembly number #21 LFX P#(A1141) to the electric clutch using (1) 7/16"-20 x 4" HHCS P#(K0359), (1) 7/16" helical spring lock washer P#(K0140) and (1) keyway P#(K1627). Torque the bolt to 55ft./lbs. Refer to Figure 2-1d.

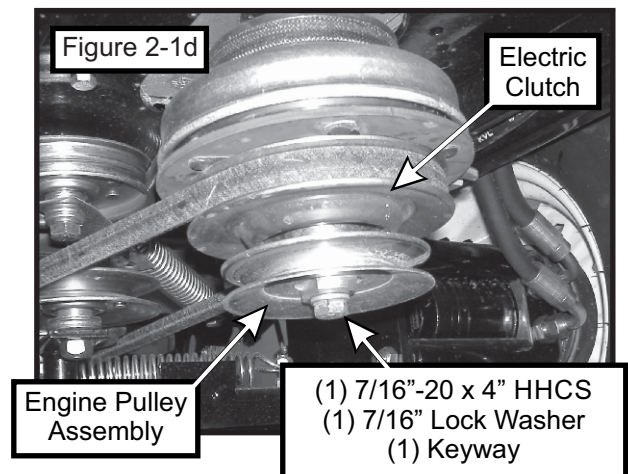

Remove the engine guard from the mower. The engine guard is secured to the frame of the mower with (2) 1/2"-13 hex bolts. Save the existing hardware for use later in the installation procedure. Remove the exhaust diverter. Refer to Figure 2-1b.

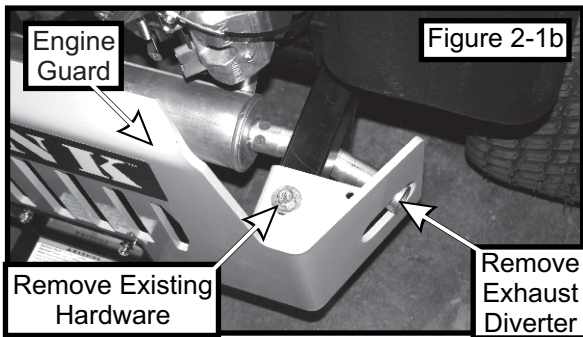

2-2 Exhaust Deflector Installation

Secure the exhaust diverter P#(J0287) to the muffler as shown in Figure 2-2, using (1) exhaust clamp P#(X1064).

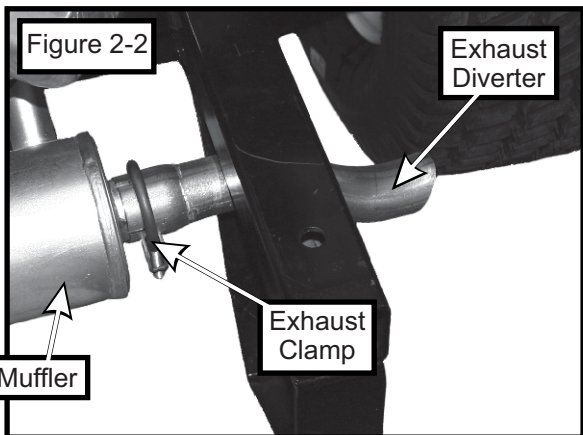

2-3 Left Lower Mount Plate And PTO Mount Plate Assembly Installation

Fasten the lower mount plate P#(B0395) and the PTO mount plate assembly P#(A0846) to the rear frame of the mower using the (2) existing bolts and (2) nuts removed from the engine guard and (2) 1/2"-13 x 1" HHCS P#(K1231) and (2) 1/2"-13 nylon flange locknuts P#(K2012). See Figure 2-3.

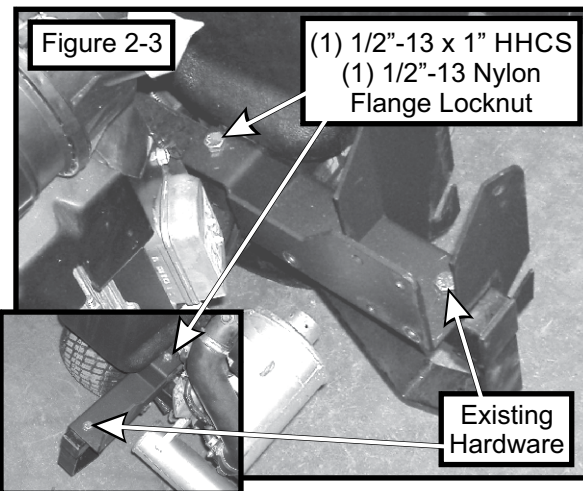

2-4 Frame Bracket Extender Installation

Installation

Secure (1) frame extender bracket P#(B0680) to the left lower mount plate P#(B0395) and (1) frame extender bracket P#(B0680) to the PTO mount plate assembly P#(A0846) using (3) 3/8"-16 x 1" HHCS P#(K1191) and (3) 3/8"-16 nylon flange locknut P#(K2038) (PER BRACKET). See Figure 2-4.

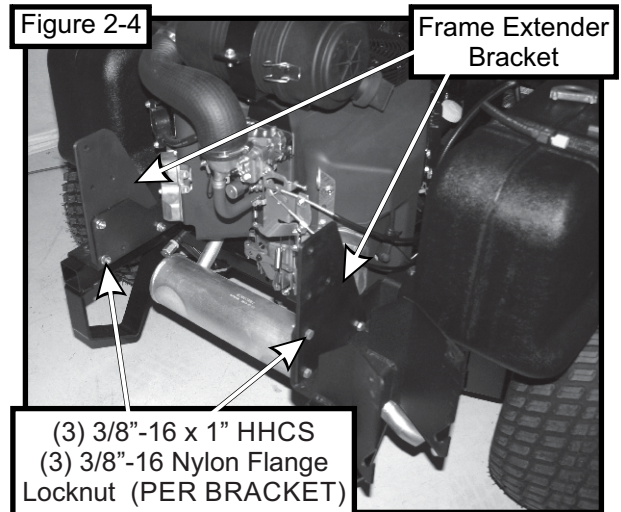

2-5 Lower Mount Assembly Installation

Installation

Secure the lower mount assembly P#(A0848) to the frame extension brackets P#(B0680) using (6) 3/8"-16 x 1" HHCS P#(K1191) and (6) 3/8"-16 nylon flange locknuts P#(K2038). Refer to Figure 2-5.

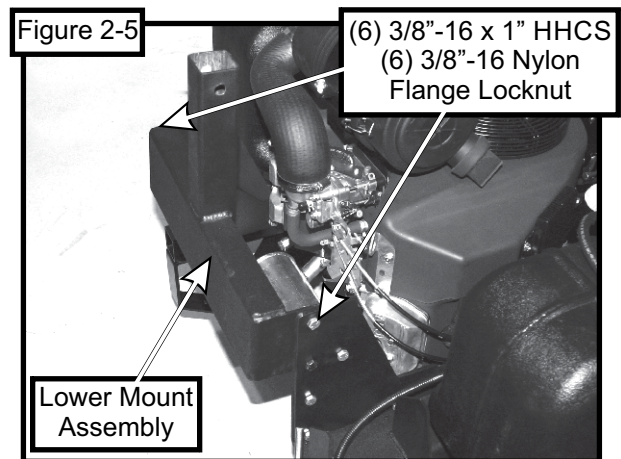

2-6 PTO Assembly Installation

Insert the PTO assembly P#(A1803) into the slots on the PTO mount plate assembly. Remove the gear box pulley guard P#(B0679) in preparation for the belt installation. Secure the PTO handle assembly P#(A0603) to the PTO assembly using (3) 1/4"-20 x 3/4" HHCS P#(K1222) and (3) 1/4"-20 nylon flange locknuts P#(K2014). After the belt has been installed, replace the gear box pulley guard and secure the PTO assembly with (1) PTO mount pin P#(B0274) and (1) hair pin clip P#(K0086). Refer to Figure 2-6 on following page.

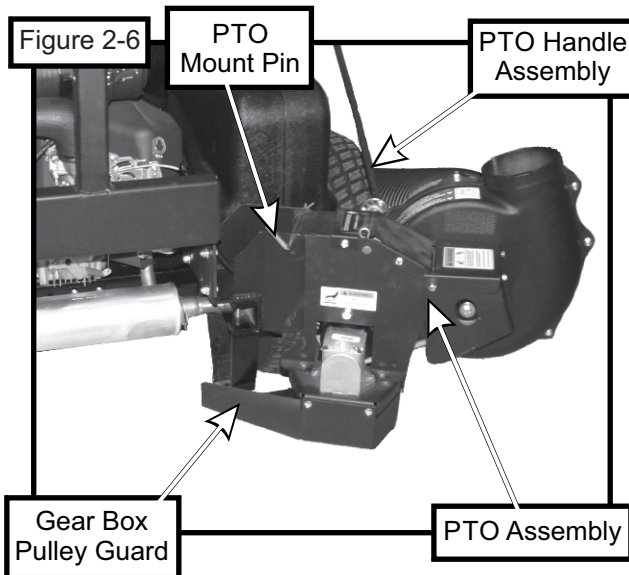

To tension the drive belt, turn the adjustment bolt clockwise (Figure 2-7d) until there is 1" of deflection, with 10-11 lbs. of pressure, at the center of the belt between the engine pulley and the gear box pulley. Once the correct tension of the belt is achieved, tighten the (4) bolts that secure the gear box assembly.

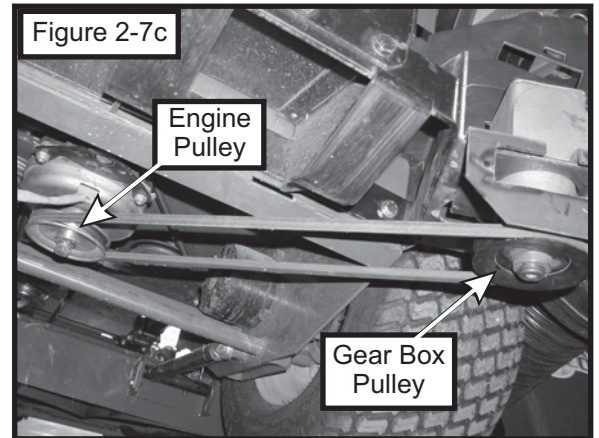

2-7 Belt Installation and Adjustment

Loosen the (4) bolts P#(K1191), (2) on each side, that secure the gear box assembly to the PTO assembly P#(A1803) (Figure 2-7a and 2-7b). Loosen the adjustment bolt P#(K0348) until the gear box assembly is at its far left adjustment (the gear box is moved toward the mower's engine pulley). Connect the kevlar cord belt A67K P#(M0109) from the engine pulley to the lower gear box pulley (Figure 2-7c).

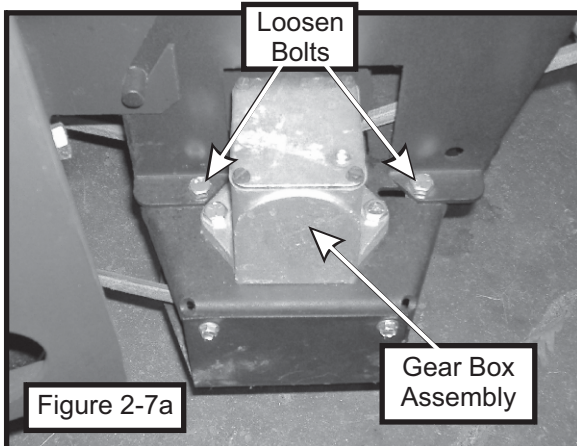
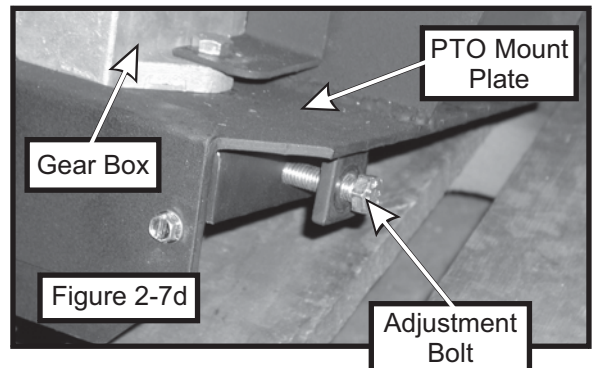

2-8 Cam Assembly Adjustment

The cam assembly P#(A0422), which controls the blower belt tension, comes from the factory pre-adjusted. If the belt is too tight or becomes too loose, remove the hair pin clip P#(K0099) from the belt tension rod P#(K0326) and pull the "L" end of the rod out of it's hole in the cam assembly. The tension rod may then be screwed out to tighten the belt or screwed in to loosen the belt. Replace the "L" end into the top hole in the cam and replace the hair pin clip. Adjust the cam stop bolt P#(K1159) to allow the cam to rotate slightly over center when the blower is disengaged (Figure 2-8).

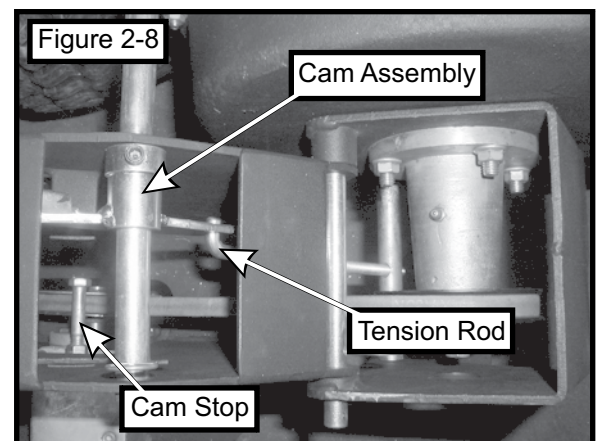
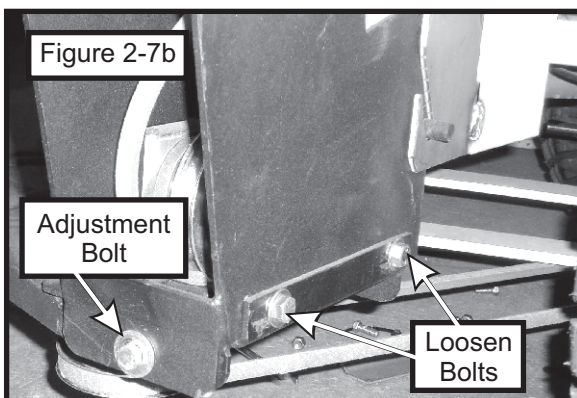

2-9 Safety Interlock Harness Installation

Lift the seat on the mower and disconnect the mower safety interlock switch shown in Figure 2-9a.

Figure 2-9a

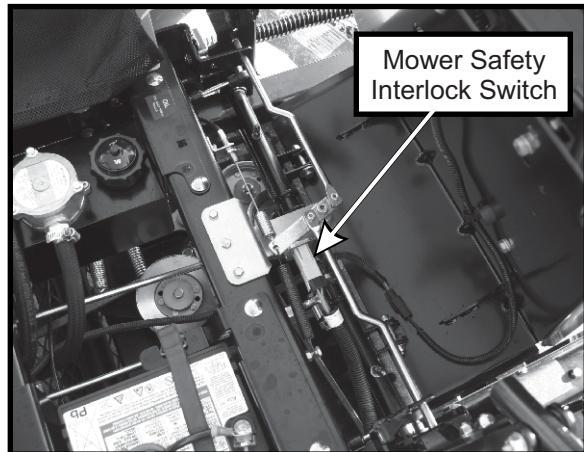

Locate the safety interlock harness P#(P0208) located on the PTO assembly. This harness will need to be connected to the mower safety interlock switch, and then secured to the mower frame with the zip ties P#(J0245) included in the mount kit hardware bag. See page 20 for the safety interlock wiring harness schematic diagram.

Figure 2-9a

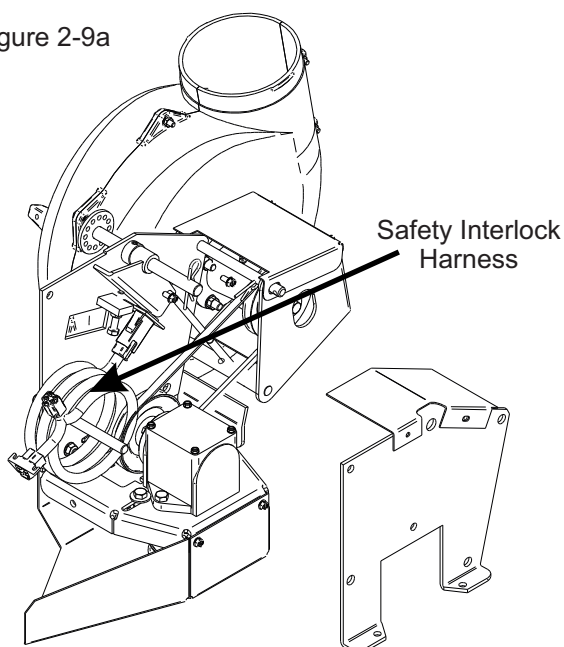

Connect the male end of the harness to the female connection on the mower, where the safety interlock switch was removed. See Figure 2-9b.

Figure 2-9b

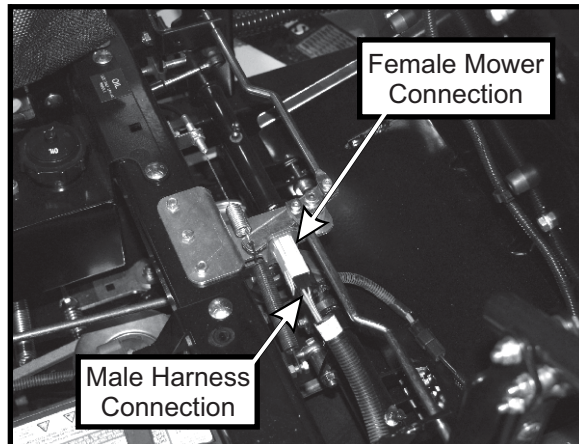

Connect the female end of the harness to the male end of the mower safety interlock switch. See Figure 2-9c.

Figure 2-9c

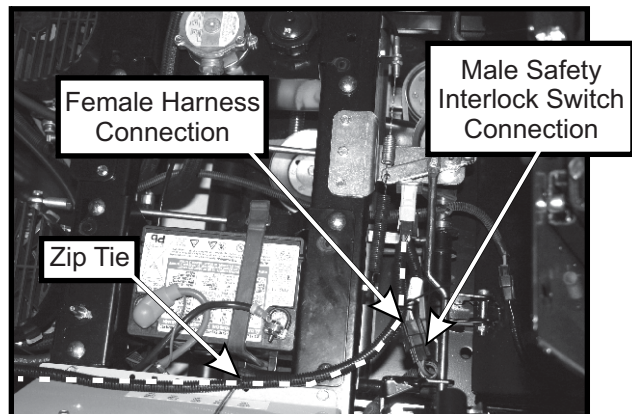

Use the plastic zip ties P#(J0245) included in the hardware bag, to secure the wiring harness to the mower. While securing, make sure mower's seat and other obstacles are clear of the harness to prevent damage. See Figure 2-9c and 2-9d.

Figure 2-9d

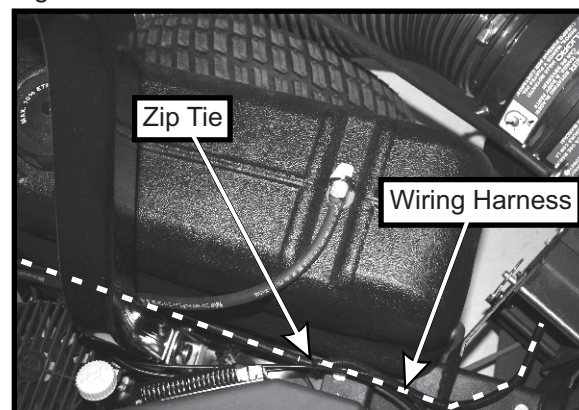

2-10 Upper Frame Assembly Installation

NOTE: During this step, it is suggested that two people install the upper frame to the lower mount tube. Using (2) people to lift the upper frame, lift the upper frame P#(A1832) above the lower mount assembly P#(A0848) making sure the frame is pointing away from the mower (Figure 2-10). Slide the upper frame tube into the lower mount assembly aligning the mounting hole. Insert (1) 1/2" x 2-1/2" clevis pin P#(K0133) through the hole and fasten with (1) 5/32" x 2-5/8" hair pin clip P#(K0088).

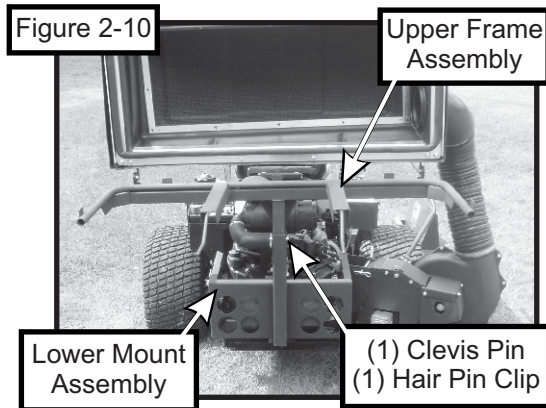

2-12 Deck Baffle Installation

A deck baffle must be installed on Select Cut model decks. Remove the front hardware from the toe guard on the deck opening. Insert the deck baffle P#(B0660) as shown in Figure 2-12. Secure the deck baffle to the mower deck using (1) 3/8"-16 x 1-1/4" carriage bolt P#(K1183) and (1) 3/8"-16 nylon flange locknut P#(K2038).

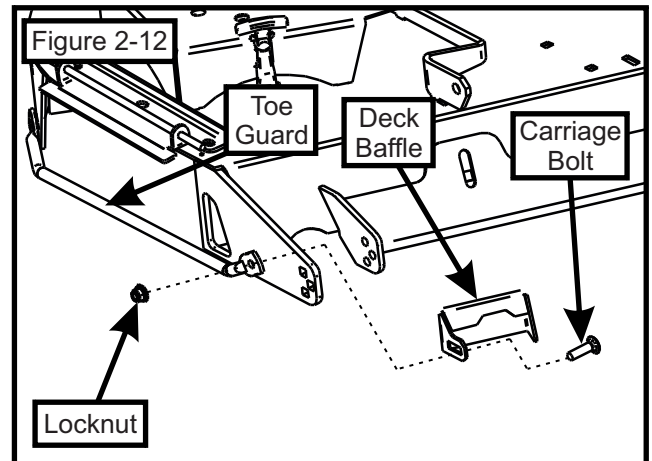

2-11 Top Assembly To Upper Frame Assembly Installation

Position the top assembly P#(A1158) above the upper frame assembly as shown in Figure 2-11. Fasten the top assembly to the upper frame assembly using (2) 5/16"-18 x 2-1/2" HHCS P#(K0125) and (2) 5/16"-18 nylon flange locknuts P#(K2516). Leave the locknuts slightly loose, to allow the top assembly to open and close easily. Refer to Figure 2-11 for hardware location.

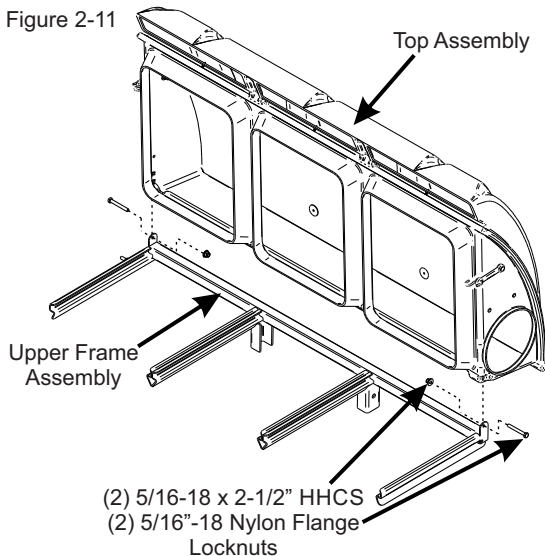

2-13 Boot To Mower Deck Installation

NOTE: The boot kit assembly is designed to fit the 48" and 60" deck. To ensure a snug fit between the boot and the mower deck, follow the instructions in this step thoroughly, and remove and tighten all hardware in the sequence specified.

Loosen (**DO NOT REMOVE**) the deflector hardware shown in Figure 2-13a.

Insert the front portion of the deck mount plate between the deflector mount bracket and the mower deck. Align the front slot of the deck mount plate with the front set of hardware on the deflector. Slide the deck mount plate to the forwardmost position and insert the rear portion of the deck mount plate between the deflector mount plate and the mower deck. Align the rear slot in the deck mount plate with the rear set of hardware on the deflector. Refer to Figure 2-13c.

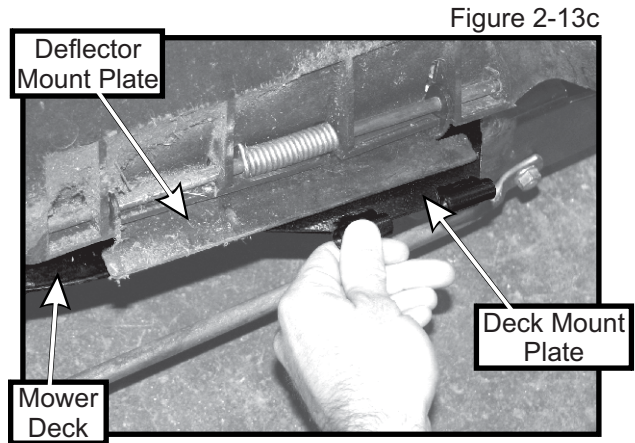
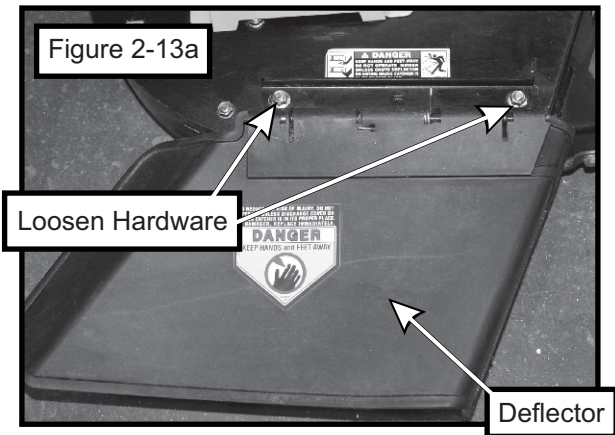

Locate the deck mount plate P#(A1120). Lift the deflector and position the deck plate as shown in Figure 2-13b.

Adjust the deck mount plate forwards/backwards so the both sets of hardware are inside the slots on the deck mount plate as shown in Figure 2-13d.

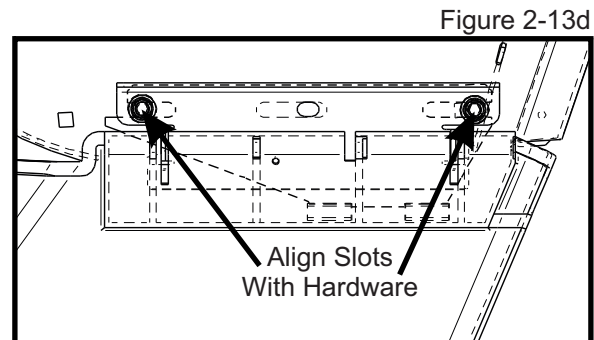
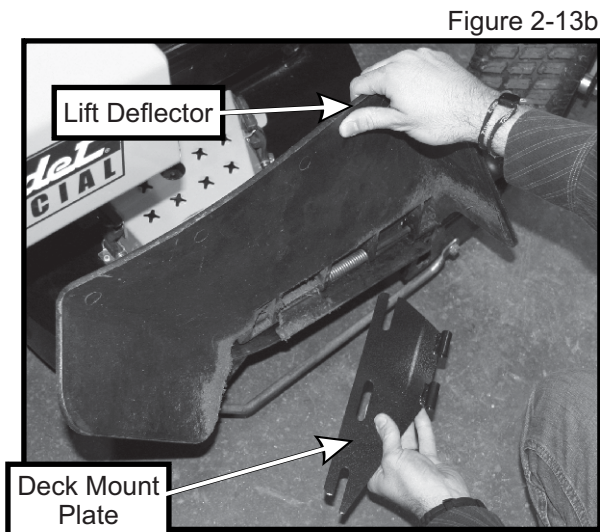

Locate the aluminum boot P#(E0021) and the boot plate assembly P#(A1121). Secure the boot plate assembly to the boot as shown in Figure 2-13k, using (2) 3/8"-16 x 1" carriage bolts P#(K1182) and (2) 3/8"-16 nylon flange locknuts P#(K2038).

NOTE: Insert the carriage bolts from inside of the boot so that the threads are on top of the boot as shown in Figure 2-13e. This will prevent grass clipping from collecting on the bolt threads. **DO NOT TIGHTEN THE HARDWARE.**

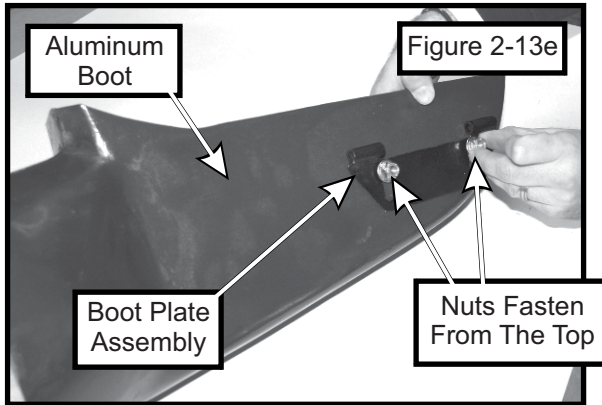

Position the boot as shown in Figure 2-13f. Align the bushing in the boot plate and the bushing in the deck mount plate. Insert the boot rod from the front of the boot as shown in the figure. Refer to Figure 2-13f.

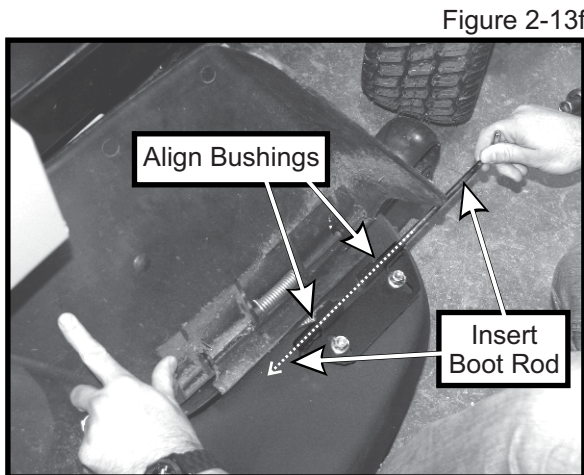

After the boot rod has been installed, slide the boot and boot plate assembly forward or backwards until a snug fit is achieved between the aluminum boot and the mower deck. To maximize the effectiveness of your collection system, you want to minimize any gaps between the boot and the mower deck. When correctly installed there should be no gaps on the top and back edge of the boot. Refer to Figure

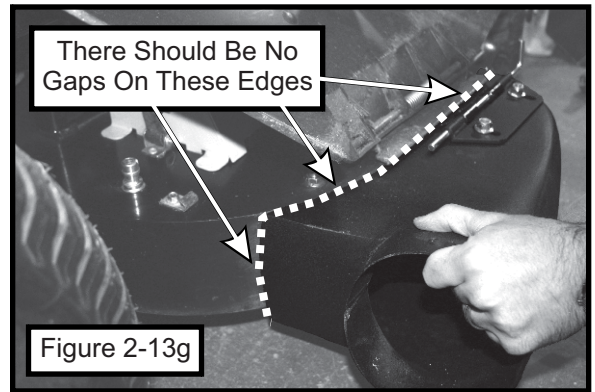

Hold the boot in position so there are no gaps between the boot and the mower deck. Then proceed to tighten the deflector hardware shown in Figure 2-13h.

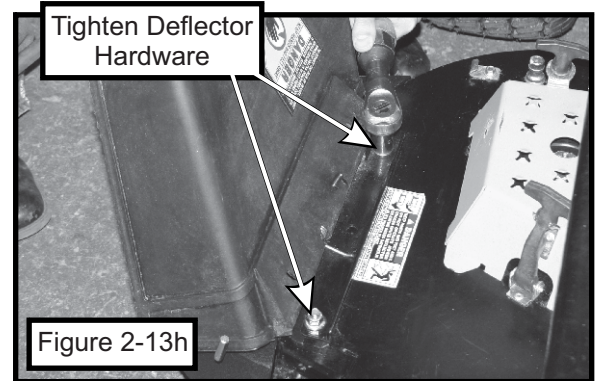

Hold the boot in position so that there are no gaps between the boot and the mower deck. Then proceed to tighten the hardware on the boot plate as shown in Figure 2-13i.

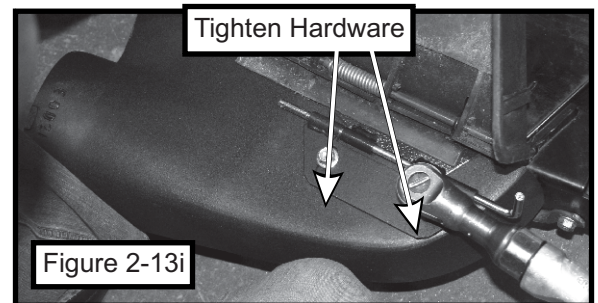

Secure the boot rod using (1) hair pin clip P#(K0099) as shown in Figure 2-13j.

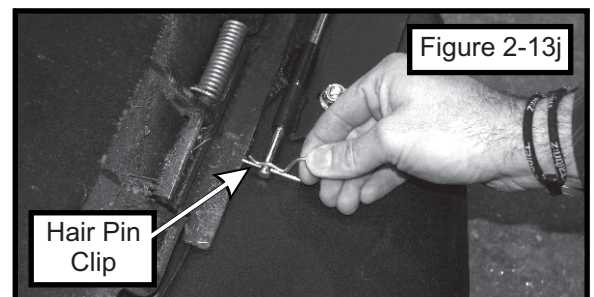

2-14 Blower Cone Installation

Thread (1) 5/16"-18 jam nut P#(K0120) onto each end of (2) 5/16"-18 x 2-1/2" HHCS P#(K0125). Now partially thread the bolts into each of the two tabs located on the blower housing. Place blower cone so the two tabs line up with the bolts then tighten completely. See Figure 2-14.

Figure 2-14

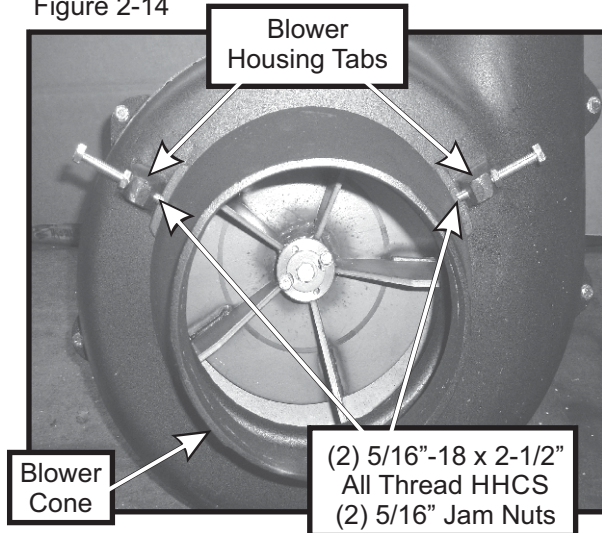

2-15 Length Of Hose Adjustment

The hoses in steps 2-16 and 2-17 must be cut to fit your machine. Follow steps 2-16 and 2-17. do not cut the hoses until you have tried to fit them on your machine. Remember that the hoses have to be long enough to adjust for the blower assembly's movement as well as allow for enough clamping surface between the inlet, blower assembly, and the deck boot.

2-16 Upper Hose Installation

Fasten the inlet to the plastic top by sliding the inlet from the inside of the top to the outside and lock into place. Slide a 6" hose clamp P#(J0060) onto both ends of the 6" upper hose (Figure 2-15). Then slide one end of the 6" hose onto the inlet. Make sure there is about a two-inch overlap between the hose end and the container inlet. Proceed to slide the opposite end of the 6" hose onto the outlet of the blower assembly. See (Figure 2-15) for details. Make sure both ends of the hose are clearly attached to the inlet and the blower assembly inlet. Tighten the hose clamps.

2-17 Lower Hose To Blower Cone Installation

Slide a 8" hose clamp P#(J0080) over both ends of the lower hose. Then proceed to slide the lower hose onto the blower cone. Tighten the hose clamp. The assembly should look like Figure 2-15.

2-18 Lower Hose To Boot Installation

Take the unattached end of the lower hose and slide it over the circular end of the boot. Use the lower hose clamp to secure the hose to the boot (Figure 2-15). Tip: Before securing clamp rotate hose counter-clockwise (away from yourself) approximately 1" to aid in retaining boot to mower deck.

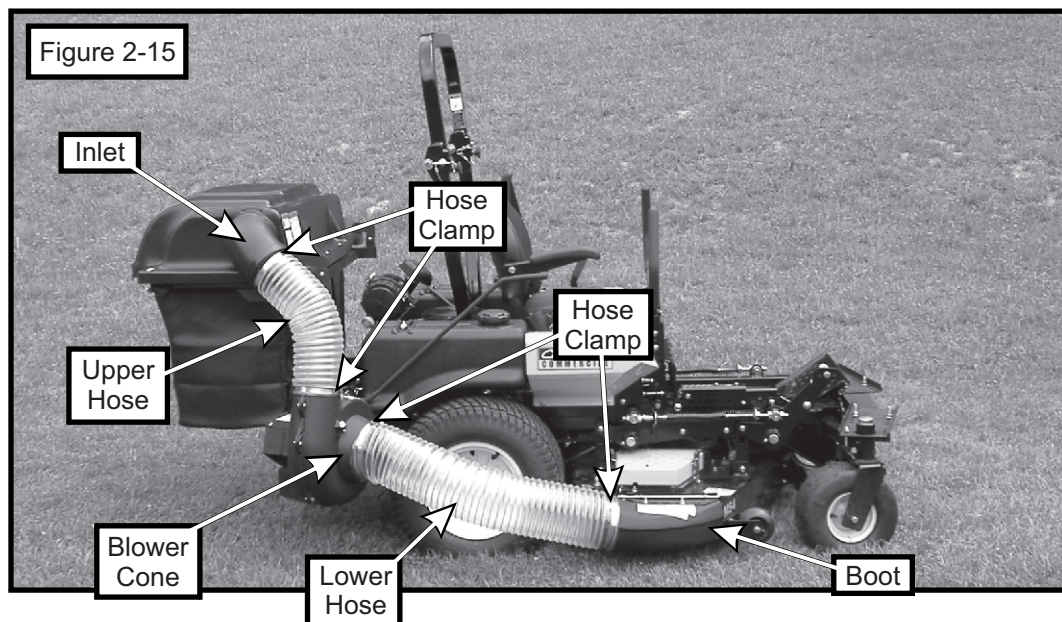

2-19 Front Weight Installation

NOTE: During this step, it is suggested that two people install the upper frame to the lower mount tube.

Secure the left and right weight brackets P#(B0383) to the front frame of the mower, using (2) 3/8"-16 x 3-1/2" HHCS P#(K1200) and (2) 3/8"-16 nylon flange locknuts P#(K2038) PER BRACKET. Lift the weight P#(B2220) into position and secure the weight to the weight bracket using (2) 1/2"-13 x 4-1/4" u-bolts P#(K0331) and (4) 1/2"-13 nylon flange locknuts P#(K2012). Refer to Figure 2-19.

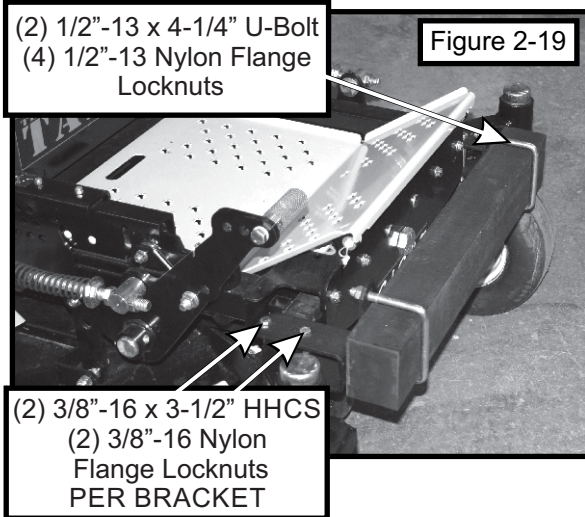

2-20 Impeller Blade Removal/Replacement

Remove the blower cone from the blower housing located on the PTO assembly P#(A1803). With the blower cone removed, you will have access to the impeller blade P#(A0645). Refer to Figure 2-20.

To Remove: First remove the 3/8"-16 x 1-1/2" HHCS P#(K1211) (#1), taper lock bushing washer P#(K0278) (#3) and spacer bushing P#(S3242) (#4) from the taper-lock bushing (#5). See Figure 2-20. Next remove the (2) 1/4"-20 x 1" HHCS (#2) and place them into the threaded holes of the taper-lock bushing P#(S4302) (#5). Gradually thread each bolt evenly into the taper-lock bushing, forcing the blade to break-away from the taper-lock bushing. If the impeller will not move, carefully hit the base of the impeller, between each vein, with a hammer, then try again.

To Replace: Place impeller blade over the engine shaft. Slide the taper-lock bushing (#5) on to the engine shaft and into the impeller blade, aligning the **non-threaded** holes of the taper-lock bushing to the threaded holes of the impeller blade. Fasten by using (2) 1/4"-20 x 1" HHCS (#2), (1) spacer bushing (#4) (1) taper lock bushing washer (#3), and (1) 3/8"-16 x 1-1/2" HHCS (#1). Torque to the proper specifications in the torque chart on the back of this manual. Next, rotate the impeller blade to ensure that the blade is clear of contact on all sides of the blower housing.



2-21 Installation/Removal Of Collection Bags

IMPORTANT!

To prevent bag wear, install (2) red plastic end caps P#(J0274), as shown in Figure 2-21a, on each bag ring before installing bags.

Figure 2-21a

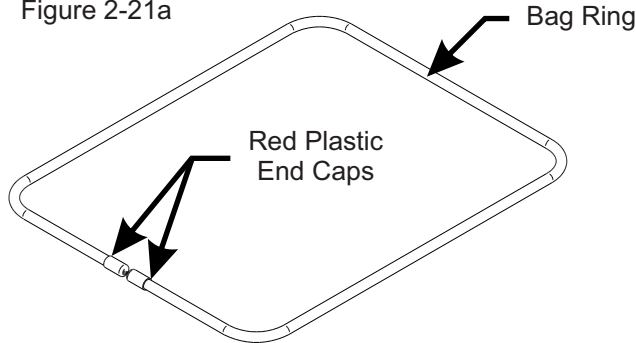

To install the bag onto the bag ring, place the seam openings of the bag onto the bag ring openings and turn the bag one full turn (360°) so the plastic end caps are located opposite to the opening in the bag (Figure 2-21b). Do this for each of three bags.

Figure 2-21b

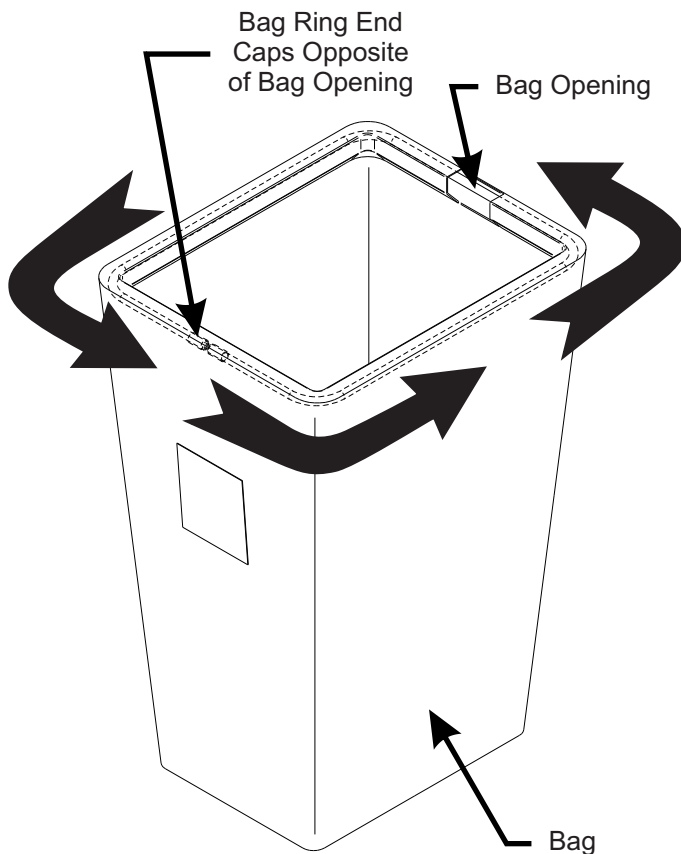

Install the completed assemblies onto the support frame and close the plastic top. Fasten both draw-latches to hold the plastic top closed (Figure 2-21c).

Figure 2-21c

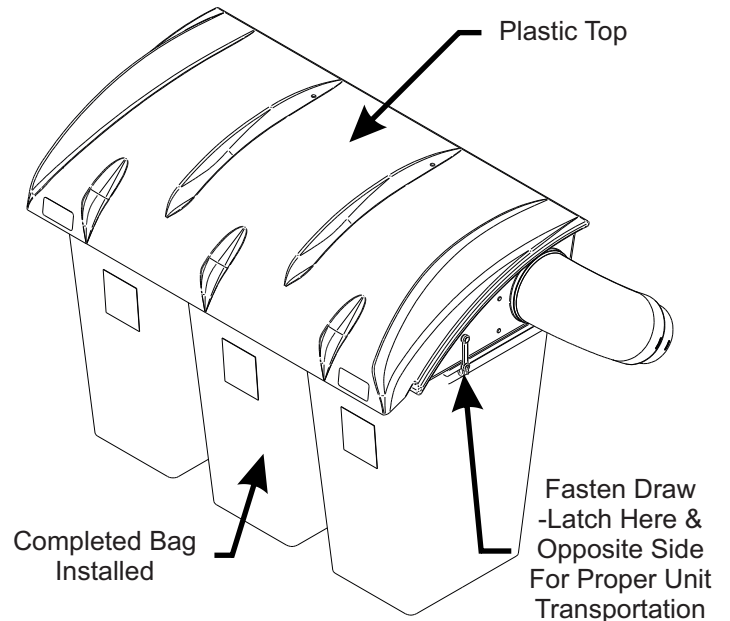

To empty the bag, first unlatch and lift top, next remove the bag and bag ring by sliding rearward, then grasp the loop on the bottom of the bag, and last turn it upside down to empty the collected debris (Figure 2-21d). Repeat for the other bags. Reinstall all bags, line with plastic bags if desired, close the plastic top and reattach the draw latches.

Figure 2-21d

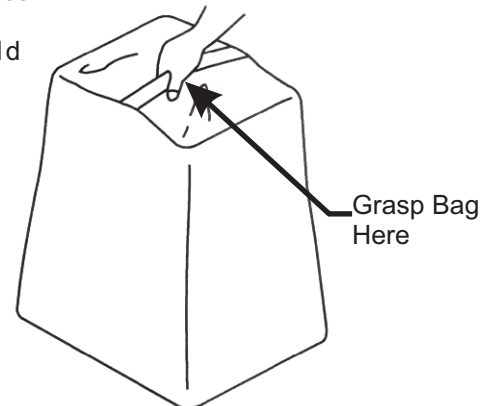

Plastic lawn and leaf bags, 33 gallon size, may be used inside the cloth bags. Be sure to leave enough plastic bag hanging over the frame so the plastic bags can be twist tied before emptying (Figure 2-21e).

Figure 2-21e

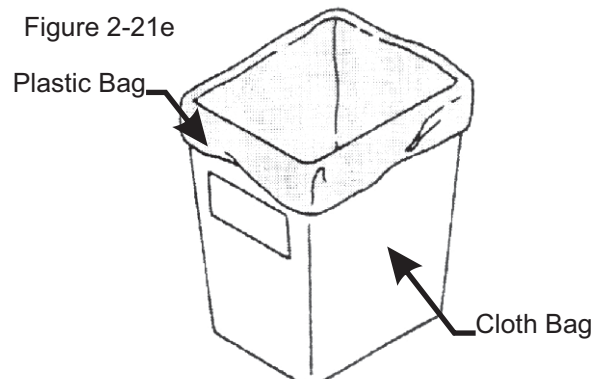

Exploded Parts View

A1158 Top Assembly

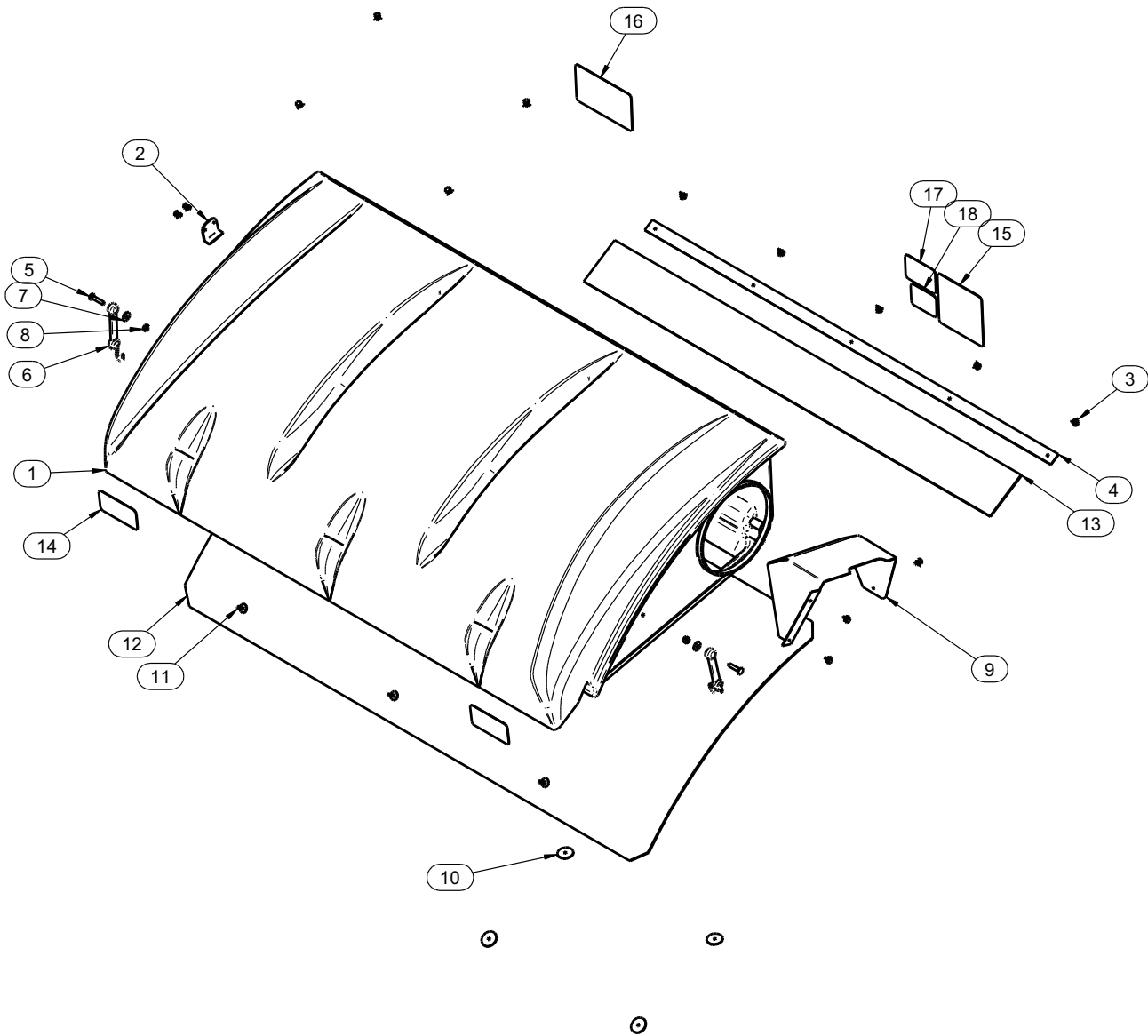

| Item # | Doc # | Title | Qty |
|--------|-------|--|-----|
| 1 | V0022 | PRO 3 BAGGER TOP | 1 |
| 2 | B0676 | Hinge Stop Pl. | 1 |
| 3 | K0114 | BLACK PLASTIC RIVET | 14 |
| 4 | C0069 | DUST GUARD BRACE | 1 |
| 5 | K1030 | 1/4"-20 x 1-1/4" CARRIAGE BOLT | 2 |
| 6 | J4009 | SHORT RUBBER STRAP W/ S HOOK | 2 |
| 7 | K0037 | 1/4" FLAT WASHER .75 OD x .314 ID x .060 T | 2 |
| 8 | K1128 | 1/4"-20 NYLOC NUT | 2 |
| 9 | C0026 | GRASS DEFLECTOR | 1 |
| 10 | K0062 | 3/16" x 1-1/2" FENDER WASHER, Z | 4 |
| 11 | K1265 | BLACK PANEL RETAINER | 3 |
| 12 | V1120 | Black Plastic Screen | 1 |
| 13 | V1118 | DUST GUARD | 1 |
| 14 | R1057 | 2" x 4" Red Reflector Label | 2 |
| 15 | R1069 | Warning - Turn Off Blower Label | 1 |
| 16 | R1065 | Made In USA Label | 1 |
| 17 | R1054 | Important Check Hoses | 1 |
| 18 | R1051 | Warning - Use Hearing Protection | 1 |

Exploded Parts View

A1803 PTO Assembly

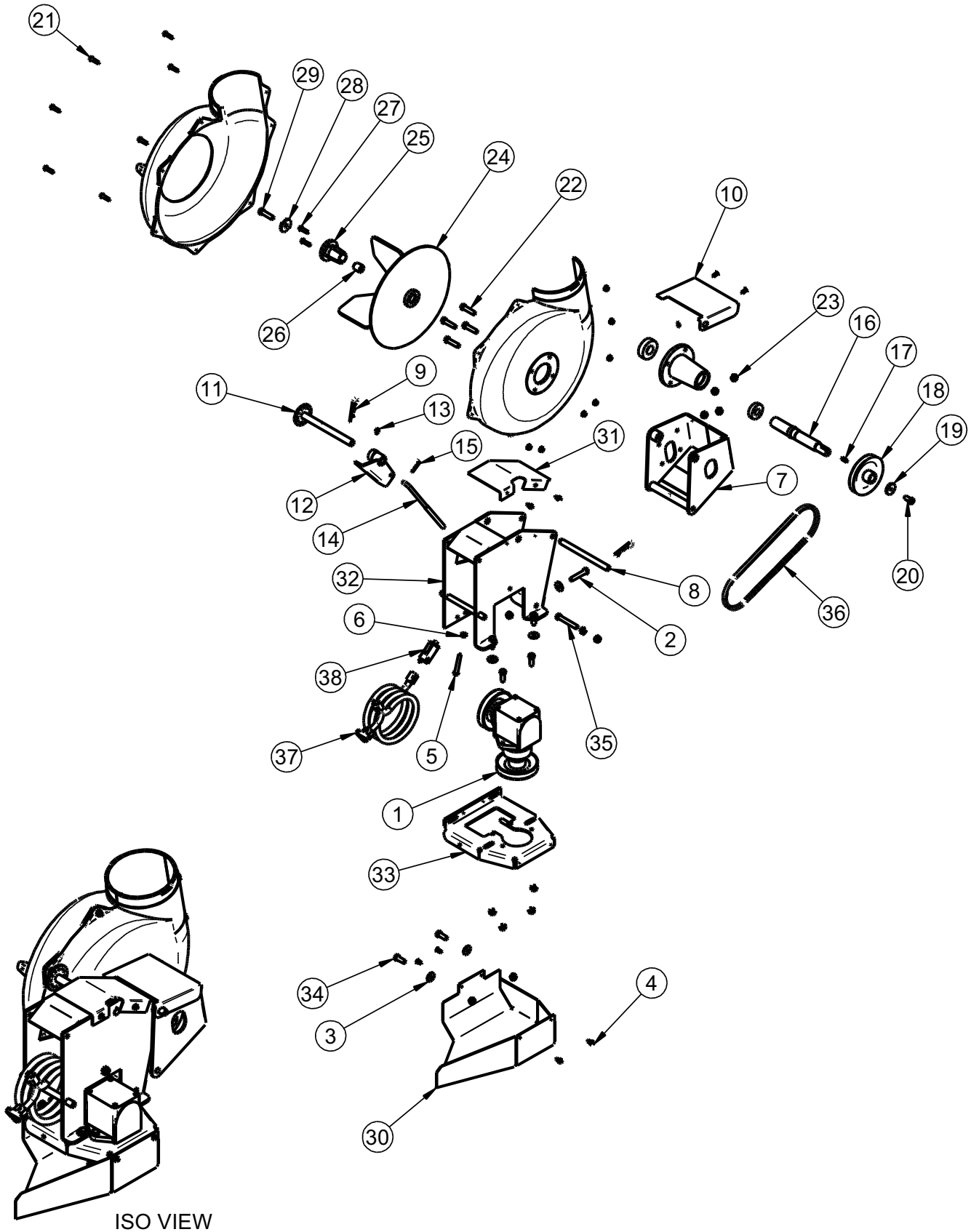

PTO Parts List

A1803 PTO Assembly

| Item Number | Document Number | Title | Quantity |
|-------------|-----------------|---|----------|
| 1 | A1822 | GEAR BOX ASSEMBLY | 1 |
| 2 | K0348 | 3/8"-16 x 2" ALL THREAD HHCS | 1 |
| 3 | K0047 | 3/8" FLAT WASHER 1.00 OD x .446 ID x .075 T | 5 |
| 4 | K0353 | 1/4"-20 x 1/2" HHSTS | 8 |
| 5 | K1159 | 5/16"-18 x 2" ALL THREAD HHCS | 1 |
| 6 | K1178 | 5/16"-18 FLANGE NUT | 1 |
| 7 | A0144 | BLOWER MOUNT BRACKET ASSEMBLY | 1 |
| 8 | B1755 | BLOWER PIVOT ROD | 1 |
| 9 | K0086 | .125 OD x 2.50 HAIR PIN CLIP | 2 |
| 10 | B0121 | BLOWER BELT GUARD | 1 |
| 11 | A0604 | PTO HANDLE MOUNT ASSY | 1 |
| 12 | A0422 | CAM BRACKET ASSEMBLY | 1 |
| 13 | K0356 | 3/8"-16 TAPERED SET SCREW | 1 |
| 14 | K0326 | BELT TENSION ROD 3/8"-16 | 1 |
| 15 | K0130 | .091 OD x 1.625 L HAIR PIN CLIP | 1 |
| 16 | A0306 | PTO SHAFT ASSEMBLY | 1 |
| 17 | J0254 | 3/16" SQ. x 3/4" LONG KEYWAY | 1 |
| 18 | M0228 | BLOWER PULLEY | 1 |
| 19 | K1446 | 1.187 OD x .380 ID x .187 WASHER | 1 |
| 20 | K1190 | 3/8"-16 x 3/4" HHCS | 1 |
| 21 | E4004A | BLOWER HSG. ASSY. | 1 |
| 22 | K1193 | 3/8"-16 x 1-1/2" HHCS | 4 |
| 23 | K1215 | 3/8"-16 FLANGE NUT | 12 |
| 24 | A0645 | SMALL 4-BLADE IMPELLER | 1 |
| 25 | S4302 | TAPER-LOCK BUSHING | 1 |
| 26 | S3242 | PLATED BUSHING | 1 |
| 27 | K1225 | 1/4"-20 X 1" HHCS GRADE 8 | 2 |
| 28 | K0278 | TAPER-LOCK BUSHING WASHER | 1 |
| 29 | K1211 | 3/8"-16 x 1-1/2" HHCS GRADE 8 | 1 |
| 30 | B0679 | GEAR BOX PULLEY GUARD | 1 |
| 31 | B0270 | PTO ARM GUARD | 1 |
| 32 | A1804 | PTO ARM ASSY. | 1 |
| 33 | A0624 | BASE PLATE ASSY. | 1 |
| 34 | K1191 | 3/8"-16 x 1" HHCS | 6 |
| 35 | K1197 | 3/8"-16 X 2 1/2" HHCS | 1 |
| 36 | M0250 | A30K KEVLAR BELT | 1 |
| 37 | P0208 | SAFETY INTERLOCK HARNESS | 1 |
| 38 | P0209 | PLUNGER SWITCH | 1 |

Unit Model #: 21131506

Mower: Cub Cadet Commercial

Mower Type: L48 25KH, L60 27KH, M48 25KH, M54 27KH, M60 27KH & M60 31KW FX

Deck Size: 48", 54" & 60"

Deck Type: Sloped Nose & Select Cut*

Vac Type: 15 Cu. Ft. Pro 3 Bagger

Drive Type: Rear PTO Drive

Revision #: Final Release 3/11/2013

Fits Year(s): 2009 - 2011

☐ A1127 Vac Kit

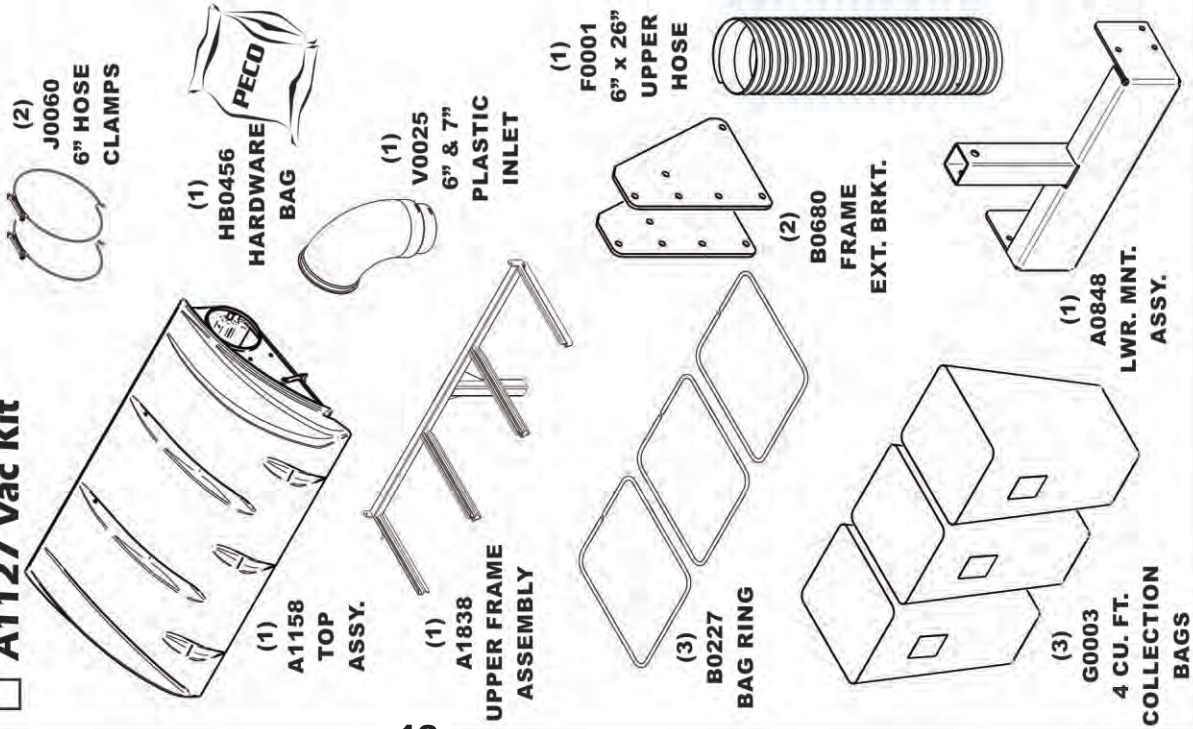

☐ A1123 Mount Kit

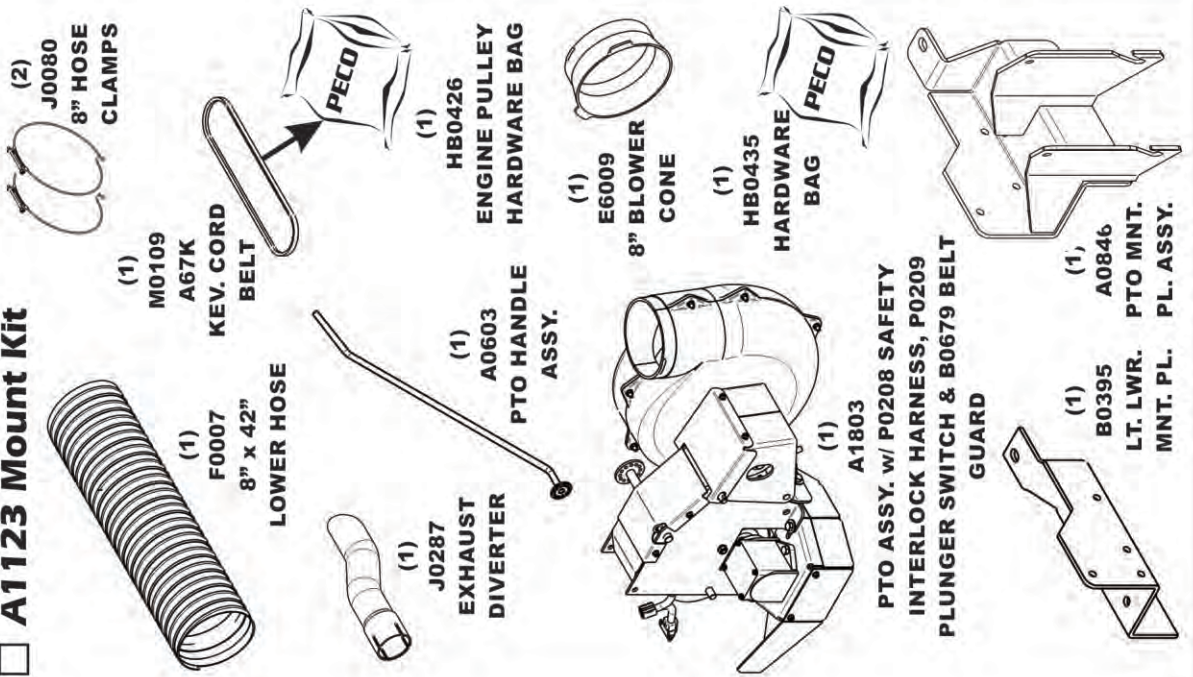

☐ A1122 Boot Kit

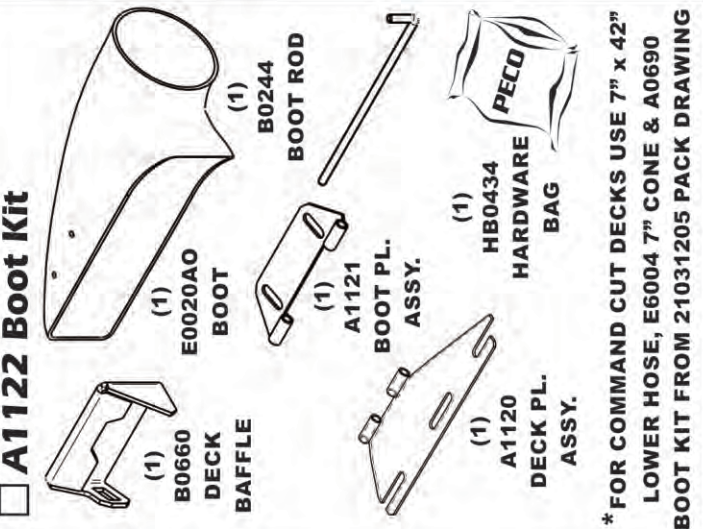

☐ A1784 Weight Kit

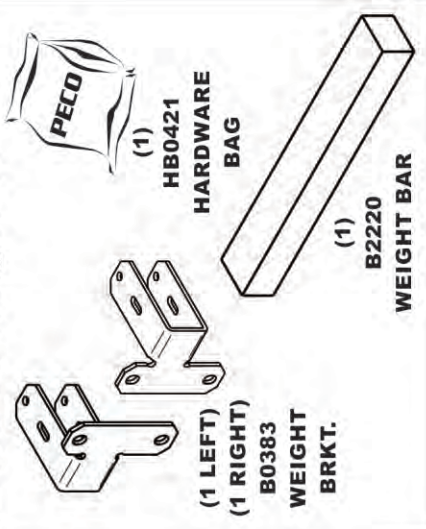

* FOR COMMAND CUT DECKS USE 7" x 42" LOWER HOSE, E6004 7" CONE & A0690 BOOT KIT FROM 21031205 PACK DRAWING



P0208
Safety Interlock
Wiring Harness

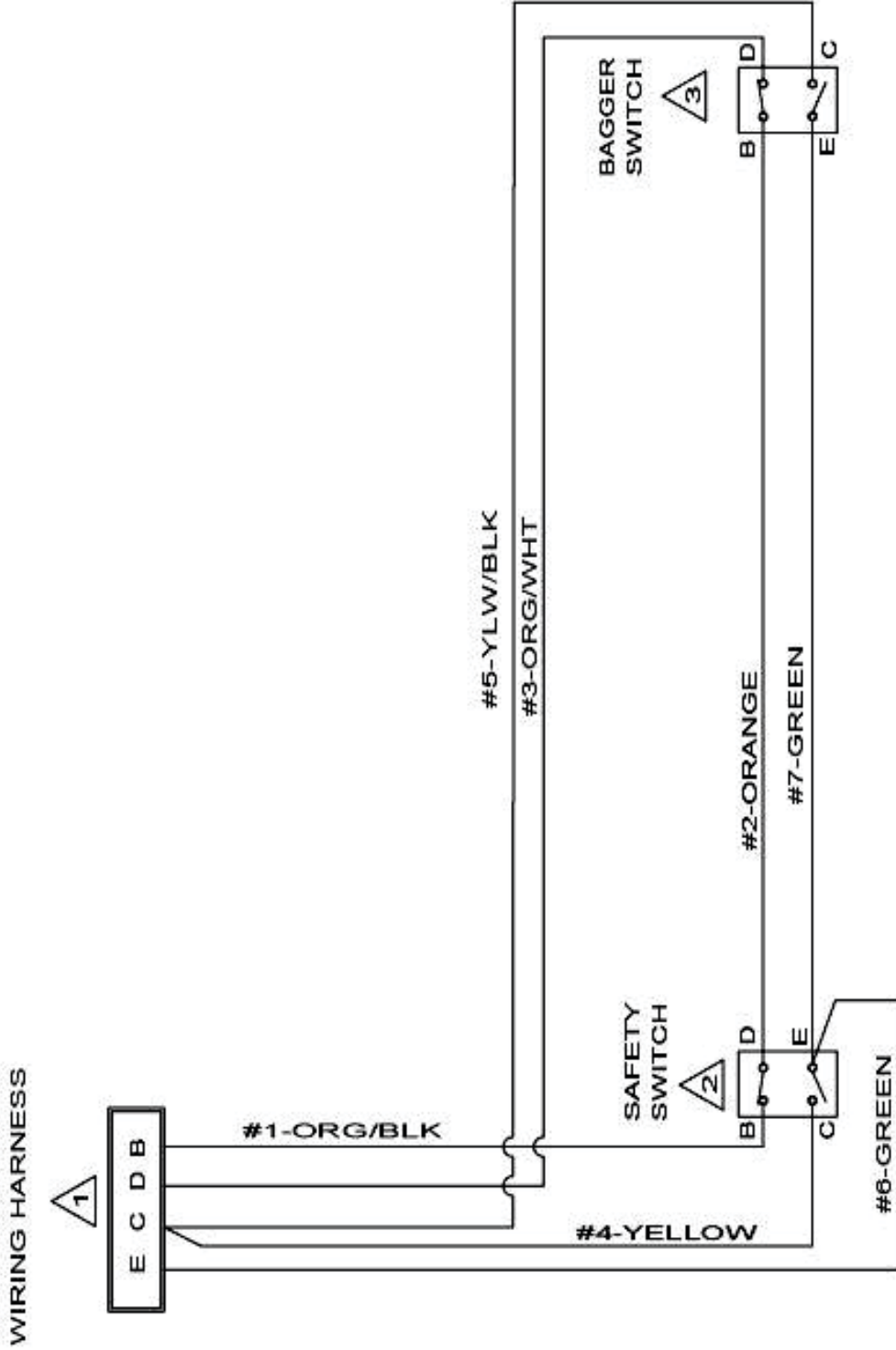

SECTION III OPERATING INSTRUCTIONS

3-1 General Safety

Only qualified people familiar with this operator's manual and the mower's operator's manual should operate this machine.

3-2 Operation And Tips On Mowing

- A. Perform BEFORE EACH USE the maintenance list in paragraph 4-1.
- B. Start mower.
- C. With the mower at high idle speed, engage the mower deck.
- D. While seated in the operator's seat, rotate the engagement handle of the collection system away from the mower. Continue to rotate the handle until it stops in an over center position. With the blower engaged, you can proceed to operate the control levers of the mower.

NOTE: If the collection system does not appear to be collecting the grass clippings, disengage the deck and blower, then, engage the parking brake and turn the mower off. Proceed to section 3-3, and review the section 2-7 and 2-8, in this manual.

To obtain the maximum effectiveness from your collection system the tips listed below should be followed:

- * Watch your speed- Normal conditions will allow a speed of up to approximately 5 mph, but thick, heavy damp conditions will require reduced ground speed.
- * Mow with sharp blades- A sharp blade cuts cleaner.
- * Wet grass and leaves will decrease effectiveness and will increase horsepower requirements.
- * Mow at higher cutting heights- Remove and mulch no more than 2" of grass length with each mowing. (Experts recommend not cutting off more than 1/3 of the grass blade length at any given time.)
- * Mow twice, at different height settings, (high, then low), if grass is extra tall.
- * Remember that horsepower requirements will vary with the mowing conditions such as type and height of turf grass, moisture content, amount of leaves, whether the terrain is flat or hilly, etc.

3-3 Disengagement Of The Blower

- A. To disengage the blower, rotate the engagement handle towards the mower.

WARNING: The blower will continue to spin. DO NOT TOUCH the blower, pulleys, or the belt until the tractor is turned off. DO NOT adjust the belt tension until the mower is turned off. Refer to section 2-7 of the manual.

3-4 Unloading The Collection System

NOTE: To determine when the collection bags are full, follow the following steps:

- A. Stop the forward movement of the mower.
- B. Disengage the mower deck.
- C. Disengage the blower.
- D. Engage the parking brake.
- E. Once the parking brake has been engaged, then and only then, walk behind the mower and check the collection bags by lifting the plastic hood. Load in bags should not exceed the height of the installed bag.
- F. To release bags from frame, lift bag ring from tab on bagger frame, slide bag out and turn bags over to deposit clippings.
- G. Follow steps on page 12 to re-attach bags back to the bagger.

NOTE: Do not allow collection bags to become over-filled as potential damage may occur to your equipment. Also, be sure to clean the hood screen as needed.

SECTION IV MAINTENANCE

4-1 Maintenance Checklist

NOTE: REMOVE PTO ASSEMBLY BEFORE RAISING DECK FOR MAINTENANCE.

Before each use:

1. Check blades and spindles to be sure that no foreign objects, such as wire or steel strapping bands, are wrapped around them.
2. Inspect blades for wear. Replace if necessary. If it is necessary to sharpen the blades, remove the blades from the spindles before sharpening. DO NOT sharpen blades while still attached to the mower.

3. Make sure all shields are in place and in good condition. Repair or replace any missing or damaged shields.
4. Perform lubrication per paragraph 4-2.
5. Listen for abnormal sounds, which might indicate loose parts, damaged bearings, or other damage. Correct any deficiency before continuing operation.
6. With the engine off, engage the blower assembly. Check the belt tension and inspect the pulley belt for cracks or tears.
7. Check for wear or deterioration of the upper or lower hoses. If there are any portions of the hose that have been torn or worn through, replace with genuine PECO parts.

After Each Use:

1. Clean all debris from machine especially from the container, underneath the belt shields, and safety decals. Replace any missing or illegible decals.
2. Inspect the unit for worn or damaged components. Repair or replace before the next use. Any replacement component installed during repair shall include the component's current safety decal specified by the manufacturers to be affixed to the component.
3. Check belt for proper tension.

THE SERIAL NUMBER PLATE IS LOCATED ON THE TOP ASSEMBLY P#(A0551)

| | |
|------------------------------------|----------------------|
| PECO | |
| OUTDOOR POWER EQUIPMENT | |
| Model Number | <input type="text"/> |
| Serial Number | <input type="text"/> |
| Arden, North Carolina 28704 | |

WRITE THE MODEL AND SERIAL NUMBER IN THE BOX ABOVE FOR FUTURE REFERENCE.

4-2 Lubrication

NOTE: Use only white lithium based grease for lubrication of the shaft on the blower assembly.

1. On initial use: Grease the fitting on the blower shaft.
2. Every 25 hours of use: Re-grease the grease fitting.
3. Every 200 hours of use: Check oil levels in gear box. Oil in gear box should cover the gears. If not, fill using an EP90 weight oil. 6oz. will fill the gear box from empty.

SECTION V PARTS AND SERVICE

5-1 Parts And Service Information

PECO collection system owners should record the name and telephone number of their Service Center. Your Service Center will be happy to supply replacement parts, accessories, and do any service or repairs to your collection system. If for any reason your Service Center is unable to service your collection system or supply replacement parts, contact PECO and include the following information on the chart below.

Unit Model Number: _____

Unit Engine Size: _____

Unit Serial Number: _____

Date of purchase: ____/____/____

Dealer/Distributor Name: _____

Address _____ **State:** _____ **Zip:** _____

Phone Number: _____

Address: New PECO Inc.

10 Walden Drive

Arden, NC 28704

Phone #: (828) 684-1234 or Toll Free: (800) 438-5823

Email: peco@lawnvac.com

SAFETY DECALS

To promote safe operation, PECO supplies safety decals on all products manufactured. Damage can occur to safety decals either through shipment, use or reconditioning. Contact your local Service Center for replacement decals.



Part #: R1054
Important Label



Part #: R1069
Warning: Turn Off Blower Label



Part #: R1057
Red Reflector Label



Part #: R4015
Danger: Rotating Blade Label

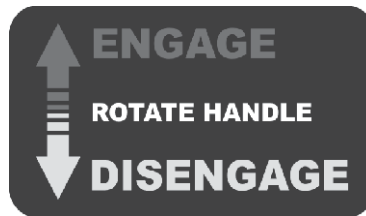

Part #: R1083
Engage/Disengage Label



Part #: R1065
Made In America Label



Part #: R4008
Caution: Rotating Blades Label

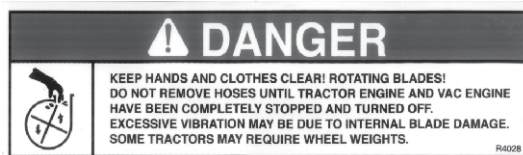

Part #: R4028
Danger Keep Hands & Clothes Clear Label



Part #: R1051
Warning: Hearing Protection Label



Part #: R1052
Small Warning: Turn Off Blower Label



Part #: R4037
Warning: Hot Surface Label



Part #: R1090
Pro Bagger Logo Label

TORQUE SPECIFICATIONS

Proper torque for American fasteners used on Peco equipment.
Recommended Torque in Foot Pounds (Newton Meters).*

AMERICAN Bolt Head Markings

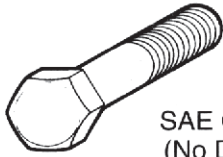

SAE Grade 2
(No Dashes)

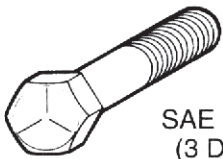

SAE Grade 5
(3 Dashes)

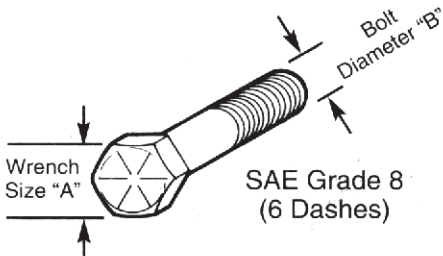

SAE Grade 8
(6 Dashes)

| WRENCH SIZE (IN.) "A" | BOLT DIAMETER (IN.) "B" AND THREAD SIZE | SAE GRADE 2 | SAE GRADE 5 | SAE GRADE 8 |
|-----------------------|---|-------------|-------------|-------------|
| 7/16 | 1/4 - 20 UNC | 6 (7) | 8 (11) | 12 (16) |
| 7/16 | 1/4 - 28 UNF | 6 (8) | 10 (13) | 14 (18) |
| 1/2 | 5/16 - 18 UNC | 11 (15) | 17 (23) | 25 (33) |
| 1/2 | 5/16 - 24 UNF | 13 (17) | 19 (26) | 27 (37) |
| 9/16 | 3/8 - 16 UNC | 20 (27) | 31 (42) | 44 (60) |
| 9/16 | 3/8 - 24 UNF | 23 (31) | 35 (47) | 49 (66) |
| 5/8 | 7/16 - 14 UNC | 32 (43) | 49 (66) | 70 (95) |
| 5/8 | 7/16 - 20 UNF | 36 (49) | 55 (75) | 78 (106) |
| 3/4 | 1/2 - 13 UNC | 49 (66) | 76 (103) | 106 (144) |
| 3/4 | 1/2 - 20 UNF | 55 (75) | 85 (115) | 120 (163) |
| 7/8 | 9/16 - 12 UNC | 70 (95) | 109 (148) | 153 (207) |
| 7/8 | 9/16 - 18 UNF | 79 (107) | 122 (165) | 172 (233) |
| 15/16 | 5/8 - 11 UNC | 97 (131) | 150 (203) | 212 (287) |
| 15/16 | 5/8 - 18 UNF | 110 (149) | 170 (230) | 240 (325) |
| 1-1/8 | 3/4 - 10 UNC | 144 (195) | 266 (360) | 376 (509) |
| 1-1/8 | 3/4 - 16 UNF | 192 (260) | 297 (402) | 420 (569) |
| 1-5/16 | 7/8 - 9 UNC | 166 (225) | 430 (583) | 606 (821) |
| 1-5/16 | 7/8 - 14 UNF | 184 (249) | 474 (642) | 668 (905) |
| 1-1/2 | 1 - 8 UNC | 250 (339) | 644 (873) | 909 (1232) |
| 1-1/2 | 1 - 12 UNF | 274 (371) | 705 (955) | 995 (1348) |
| 1-1/2 | 1 - 14 UNF | 280 (379) | 721 (977) | 1019 (1381) |
| 1-11/16 | 1-1/8 - 7 UNC | 354 (480) | 795 (1077) | 1288(1745) |
| 1-11/16 | 1-1/8 - 12 UNF | 397 (538) | 890 (1206) | 1444 (1957) |
| 1-7/8 | 1-1/4 - 7 UNC | 500 (678) | 1120 (1518) | 1817 (2462) |
| 1-7/8 | 1-1/4 - 12 UNF | 553 (749) | 1241 (1682) | 2013 (2728) |
| 2-1/16 | 1-3/8 - 6 UNC | 655 (887) | 1470 (1992) | 2382 (3228) |
| 2-1/16 | 1-3/8 - 12 UNF | 746 (1011) | 1672 (2266) | 2712 (3675) |
| 2-1/4 | 1-1/2 - 6 UNC | 870 (1179) | 1950 (2642) | 3161 (4283) |
| 2-1/4 | 1-1/2 - 12 UNF | 979 (1327) | 2194 (2973) | 3557 (4820) |

Proper torque for metric fasteners used on Peco equipment.
Recommended torque in foot pounds (newton Meters).*

METRIC

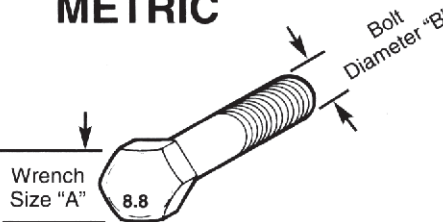

Numbers appearing on bolt heads indicate ASTM class.

| WRENCH SIZE (mm) "A" | BOLT DIA. (mm) "B" | ASTM 4.6 | ASTM 8.8 | ASTM 9.8 | ASTM 10.9 |
|----------------------|--------------------|-----------|-------------|-----------|-------------|
| 8 | 5 | 1.8 (2.4) | | 5.1 (6.9) | 6.5 (8.8) |
| 10 | 6 | 3 (4) | | 8.7 (12) | 11.1 (15) |
| 13 | 8 | 7.3 (10) | | 21.1 (29) | 27 (37) |
| 16 | 10 | 14.5 (20) | | 42 (57) | 53 (72) |
| 18 | 12 | 25 (34) | 74 (100) | 73 (99) | 93 (126) |
| 21 | 14 | 40 (54) | 118 (160) | 116 (157) | 148 (201) |
| 24 | 16 | 62 (84) | 167 (226) | 181 (245) | 230 (312) |
| 30 | 20 | 122 (165) | 325 (440) | | 449 (608) |
| 33 | 22 | | 443 (600) | | 611 (828) |
| 36 | 24 | 211 (286) | 563 (763) | | 778 (1054) |
| 41 | 27 | | 821 (1112) | | 1138 (1542) |
| 46 | 30 | 418 (566) | 1119 (1516) | | 1547 (2096) |

*Use 75% of the specified torque value for plated fasteners. Use 85% of the specified torque values for lubricated fasteners.

NOTES



**10 WALDEN DRIVE
ARDEN, NORTH CAROLINA 28704
(800) 438-5823 OR (828) 684-1234 FAX: (828) 684-0858
EMAIL: peco@lawnvac.com
WEBSITE: www.lawnvac.com**