



PRO 2 BAGGER+ GRASS COLLECTION SYSTEM

PECO MODEL#:
37120901 & 37120902

SCAG FREEDOM Z



OPERATOR'S MANUAL

ASSEMBLY ● OPERATION ● MAINTENANCE

RESIDENTIAL BAGGING SYSTEM

TABLE OF CONTENTS

SECTION	PAGE	SECTION	PAGE
Safety	2	2-14 Impeller Blade Removal and Replacement	12
Safety Alert Symbols	3	2-15 Boot To Mower Deck Installation	13
Warranty	4	2-16 Length of Hose Adjustment	14
I INTRODUCTION AND DESCRIPTION	5	2-17 Upper Hose Installation	14
1-1 Introduction	5	2-18 Lower Hose To Blower Cone Installation	14
1-2 Description	5	2-19 Lower Hose To Boot Installation	14
II INSTALLATION FOR USE	5	2-20 Weight Kit Installation	14
2-1 Preparation Of Mower	5	2-21 Installation and Removal of Collection Bags	15
2-2 Right & Left Lower Frame Plate Installation	6	III OPERATING INSTRUCTIONS	16
2-3 Rear Lower Frame Plate Installation	6	3-1 General Safety	16
2-4 Heat Guard Installation	6	3-2 Operation & Tips On Mowing	16
2-5 Lower Mount Tube Installation	7	3-3 Disengagement Of The PTO Assembly	16
2-6 Upper Frame Assembly Installation	7	3-4 Unloading The Collection System	16
2-7 Top Assy. To Upper Frame Assy. Installation	7	IV MAINTENANCE	16
2-8 Hinge Kit Installation	8	4-1 Maintenance Checklist	16
2-9 Exhaust Diverter Installation	8	4-2 Lubrication	17
2-10 PTO Mount Plate Component Installation	8-9	V PARTS AND SERVICE	17
2-11 PTO Assembly Installation	9	5-1 Parts And Service Information	17
2-12 Belt Removal and Adjustment	10-11	Exploded Views And Parts List	18-22
2-13 Blower Cone Installation	12	Safety Decals	23
		Torque Specifications	24
		Notes	25

SAFETY

1. Read the operator's manual carefully and familiarize yourself with the proper use of your attachment. Do not allow anyone who is not acquainted with the Safety Instructions to use your attachment.
2. Know the controls and how to stop quickly. **READ THE OPERATOR'S MANUAL!**
3. Do not allow children to operate the mower. Do not allow adults to operate the mower or grass collection system without proper instruction.
4. Be especially watchful of children and pets darting into the area while operating.
5. Keep your eyes and mind on your unit while mowing or operating your attachment. Don't let others distract you.
6. Do not attempt to operate your unit or mower when not in the driver's seat.
7. Always stop unit when emptying the container.
8. Stop unit, shut off deck attachment, set parking brake, shut off mower engine and remove spark plug wire before removing clogs, removing or replacing hose, boot, blower cone, or performing any maintenance.
9. If a slope must be ascended, back up the slope; drive forward when descending.
10. It is recommended that the container be kept only half full when negotiating any slopes. Start mowing on slopes when the container is empty and never mow slopes greater than 15 degrees.
11. Inspect your lawn and remove any foreign objects before mowing. Never deliberately run the mower across any foreign object.
12. Wear ear protection if the noise level is offensive.
13. Wear eye protection to prevent debris from damaging your eyes.

SAFETY

WARNING! **NEVER** operate the mower unless the discharge guard and either the deflector assembly or the vacuum collector adapter are fastened securely in place.

WARNING! Do not work around the mower deck boot or the blower area until you are certain that the mower blades and the blower impeller have stopped rotating.

WARNING! To avoid serious injury, perform maintenance on the vacuum collector; **ONLY AFTER STOPPING THE MOWER'S ENGINE AND WAITING FOR ALL MOVING PARTS TO COME TO A COMPLETE STOP.** Set the parking brake. Always remove the ignition key before beginning maintenance.

WARNING! For your own personal safety, **ALWAYS** back up the face of slopes. **NEVER** attempt to mow excessively steep slopes, and use caution when turning on any slope.

Safety Alert Symbol



This Safety Alert Symbol means: **“ATTENTION! BECOME ALERT! YOUR SAFETY IS INVOLVED!”**

This symbol is used to call attention to safety precautions that should be followed by the operator to avoid accidents. When you see this symbol, carefully read the message that follows and heed its advice. Failure to comply with safety precautions could result in death or serious bodily injury.

Safety Signs

The signal words **DANGER**, **WARNING**, and **CAUTION** are used on the equipment safety signs. These words are intended to alert the viewer to the existence and the degree of hazard seriousness.



White letters on **RED**

This signal word indicates a potentially hazardous situation which, if not avoided, will result in death or serious injury.



Black letters on **ORANGE**

This signal word indicates a potentially hazardous situation which, if not avoided, could result in death or serious injury.

It may also be used to alert against unsafe practices.



Black letters on **YELLOW**

This signal word indicates a potentially hazardous situation exist which, if not avoided, will result in minor or moderate injury.

It may also be used to alert against unsafe practices.

PECO LIMITED WARRANTY FOR NEW PRODUCTS

A. WHAT IS UNDER WARRANTY?

PECO extends the following warranties to the original purchaser of each new PECO consumer product subject to the following limitations.

1. PRODUCT WARRANTY: Any part of any consumer product, which is defective in material or workmanship as delivered to the purchaser will be repaired or replaced, as PECO elects, without charge for parts or labor, if the defect appears within 12 months from the date of delivery of the product to the original purchaser.

ALL DEFECTIVE PARTS MUST BE RETURNED TO PECO FOR INSPECTION TO DETERMINE VALIDITY OF WARRANTY CLAIMS. Freight and mailing will be borne by the customer.

2. PARTS REPLACED DURING WARRANTY: Any new PECO part which is furnished in performance of this warranty and is defective in material or workmanship as delivered to the purchaser will be repaired or replaced, as PECO elects, without charge if the defect appears within 90 days from the date of installation of such part or before the expiration of the original warranty period, whichever is later.

B. SECURING WARRANTY ADJUSTMENTS.

Call PECO for Return Authorization. Damaged or broken parts other than engines or batteries, must be returned to New PECO, Inc. 100 Airport Road, Arden, NC 28704 before any warranty adjustment can be authorized. At the time of requesting warranty adjustment, the purchaser must present evidence of the date of delivery of the product. The purchaser shall pay any charge for the product to and from Arden, NC.

C. ITEMS NOT COVERED BY PECO WARRANTY.

Engines and batteries attached to PECO products are covered under a separate warranty by the respective manufacturer.

D. UNAPPROVED ALTERATION OR MODIFICATION.

All obligations of New PECO, Inc. under this warranty shall be terminated if products are altered or modified in ways not approved by New PECO, Inc.

E. ACCIDENTS AND NORMAL MAINTENANCE.

The warranty covers only defective material and workmanship. It does not cover depreciation or damage caused by normal wear, accident, improper use or abuse of products. The cost of normal maintenance and normal replacement of service items such as belts, cutting blades, hoses, etc., which are not defective shall be paid for by the purchaser.

F. NO REPRESENTATIONS ADDITIONAL WARRANTIES, DISCLAIMER.

Neither New PECO, Inc. nor any company affiliated with it makes any warranties, representations or promises as to the quality of performance of its products other than those set forth herein. Except as described above, New PECO, Inc. makes no other warranties **AND SPECIFICALLY DISCLAIMS ANY AND ALL IMPLIED WARRANTIES OF FITNESS AND MERCHANTABILITY.**

G. ANY MACHINE USED FOR RENTAL PURPOSES ARE GUARANTEED FOR 45 DAYS FROM DATE OF ORIGINAL SALE ONLY.

H. REMEDIED EXCLUSIVE.

The only remedies the purchaser has in connection with the breach or performance of any warranty on New PECO, Inc. consumer products are set forth above. In no event will PECO be liable for special incidental or consequential damages.

1. NO SERVICE CENTER WARRANTY.

The selling Service Center makes no warranty on his own on any item warranted by New PECO, Inc. unless he delivers to purchaser a separate written warranty certificate specifically warranting the item. The dealer has no authority to make any representation or promise on behalf of PECO or to modify the terms of this warranty in any way.

Section I

INTRODUCTION & DESCRIPTION

1-1 Introduction

Your grass collection system has been designed to give you a low maintenance, simple, and effective way to collect the grass clippings from your mower. This manual is provided to give you the necessary instructions to properly mount and operate the collection system on your mower. Please read this manual thoroughly. Understand what each control is for and how to use it. Observe all safety decal precautions on the machine and noted throughout the manual.

NOTE: all references made to right, left, front, rear, top or bottom are as viewed from the normal operator's position on the mower.

1-2 Description

The grass collection system is designed for turf maintenance where there is a need to collect the grass clippings as the mower cuts the turf. It is also used for picking up leaves in pre-season and post-season clean-up. The blower, mounted on the right side of the unit, uses a belt and gearbox system from the engine PTO shaft. Drive train protection comes through belt slippage. The blower draws grass clippings from the discharge area of the cutting deck back to the (2) - 3.3 cubic foot collection bags P#(G0002) at the rear portion of the mower frame. The operator can engage the blower with a spring-lock engagement handle on the right side of the unit. Once the bags are full with clippings, they can be easily released for dumping.

Section II

INSTALLATION FOR USE

2-1 Preparation Of Mower

Remove the rear bumper from the mower frame. There are (8) 3/8" hex bolts that secure the rear bumper to the mower frame. Save this hardware for use later in the installation. See Figure 2-1a.

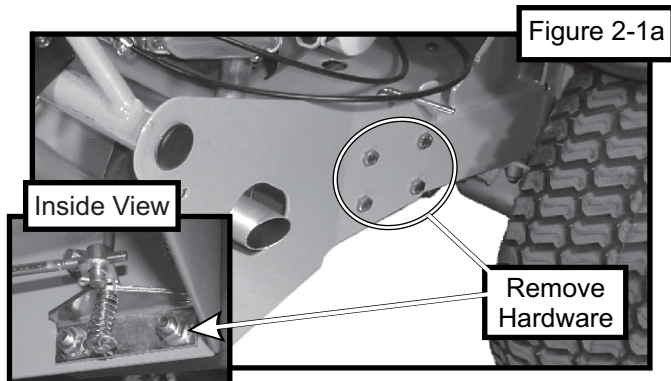

Next, check the exhaust direction, as if sitting in the Operator's Seat. If the exhaust is blowing to the Right-Hand Side, disassemble and reassemble the Diverter to point to the Left-Hand Side before continuing.

Remove the grass deflector and hardware from the mower deck as shown in Figure 2-1b.

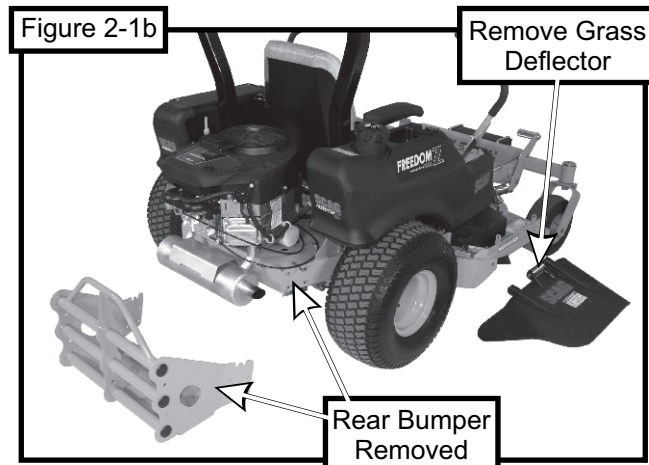

From the underside of the engine, remove the bolt and bushing from the electric clutch assembly. Use a bungee cord or similar device to hold the clutch in place while the hardware is removed.

Replace the hardware removed with the engine pulley assembly number 19 P#(A1792). Fasten the engine pulley to the electric clutch assembly using (1) 7/16" hi-collar helical spring lock washer P#(K0140) and (1) 7/16"-20 x 3-1/4" HHCS P#(K0351). See Figure 2-1c for details.

For Kawasaki FS691V-AS13: Use engine pulley assembly number 29 P#(A1203). Fasten the engine pulley to the electric clutch assembly using (1) 7/16" hi-collar helical spring lock washer P#(K0140) and (1) 7/16"-20 x 3-1/4" HHCS P#(K0351). See Figure 2-1c for details.

The added pulley will power the collection system. Torque the bolt to 55 ft./lbs.

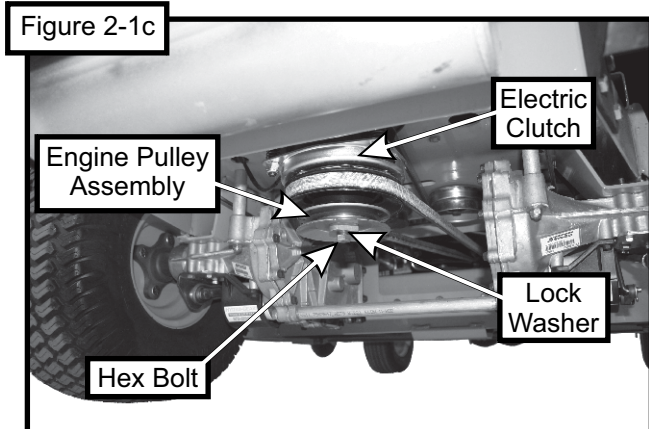

2-2 Right and Left Lower Frame Plate Installation

Fasten the right lower frame plate P#(B0730) to the rear frame of the mower using the (4) existing 3/8"-16 hex bolts and (4) 3/8"-16 nuts from the right rear bumper. Leave the hardware slightly loose until the heat guard from section 2-4 has been installed. Refer to Figure 2-2a.

Figure 2-2a

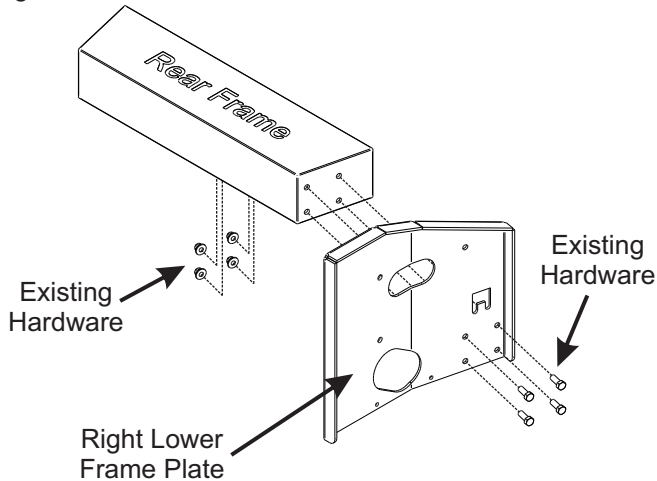

Fasten the left lower frame plate P#(B0729) to the rear frame of the mower using the (4) existing 3/8"-16 hex bolts and (4) 3/8"-16 nuts from the right rear bumper. Leave the hardware slightly loose until the heat guard from section 2-4 has been installed. Refer to Figure 2-2b.

Figure 2-2b

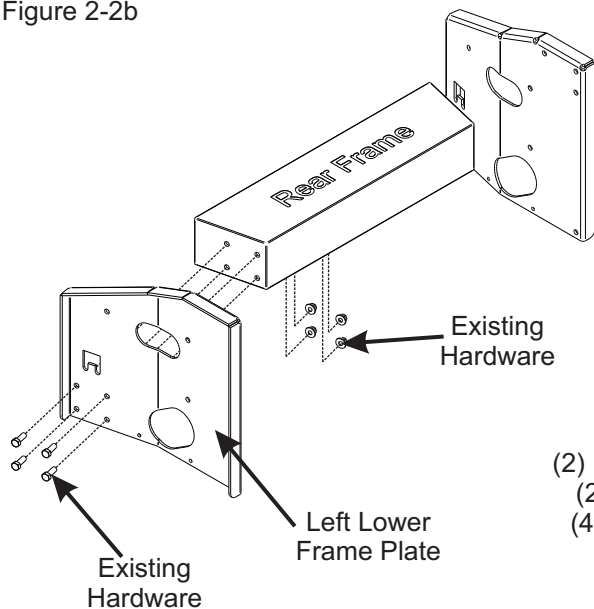

2-3 Rear Lower Frame Plate Installation

Fasten the top portion of the rear lower frame plate P#(B0728) to the left and right lower frame plate using (2) 3/8"-16 x 1" HHCS P#(K1191) and (2) 3/8"-16 nylon flange locknuts P#(K2038). Leave hardware slightly loose until the heat guard from section 2-4 has been installed. Refer to Figure 2-3.

Figure 2-3

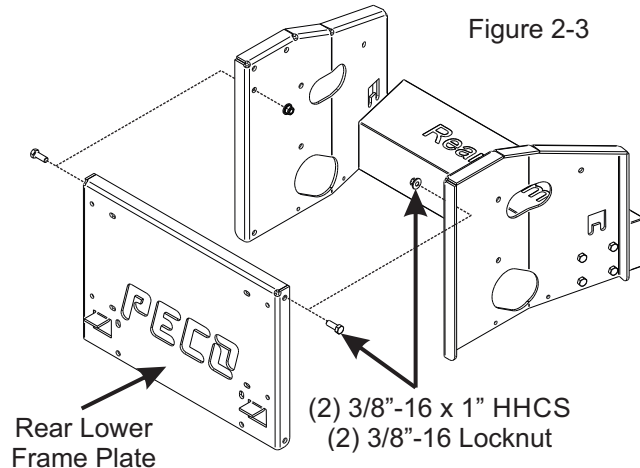

2-4 Heat Guard Installation

Secure front holes of heat shield P#(B0890) to left lower frame plate and right lower frame plate, using (2) 1/4"-20 x 3/4" HHCS P#(K1222), (2) 1/4"-20 nylon flange locknuts P#(K2014) and (4) 1/4" Flat Washers P#(K0037). Secure rear holes using (2) 3/8"-16 x 1" HHCS P#(K1191) and (2) 3/8"-16 nylon flange locknuts P#(K2038). Once the heat shield has been installed, tighten all frame plate hardware. Refer to Figure 2-4.

Figure 2-4

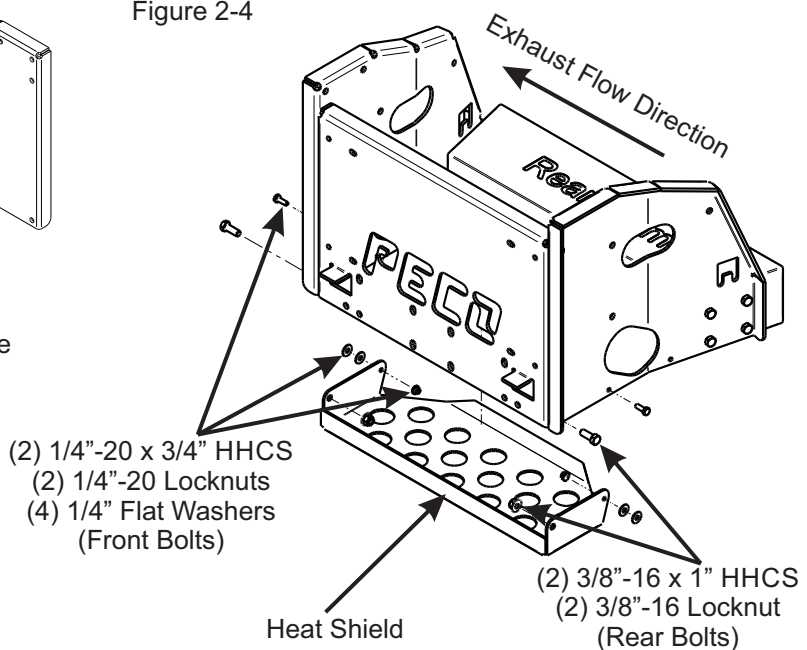

2-5 Lower Mount Tube Installation

Secure the (2) lower mount tubes P#(B0752) to the rear lower frame plate using (2) 5/16"-18 u-bolts P#(K1098) and (4) 5/16"-18 nylon flange locknuts P#(K2516) PER TUBE. Refer to Figure 2-5.

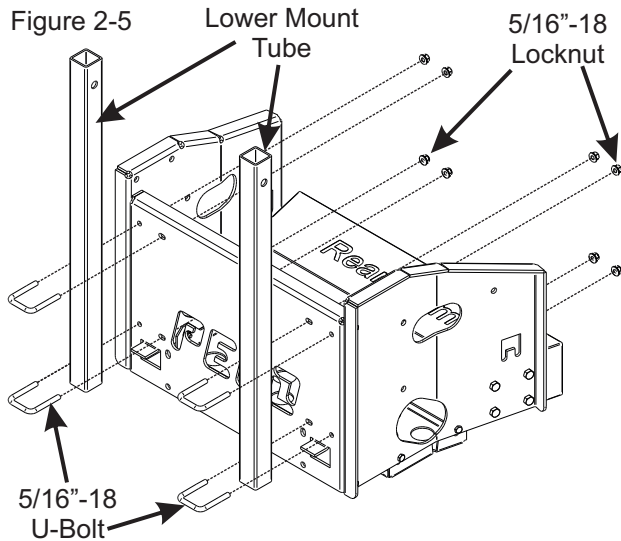

2-6 Upper Frame Assembly Installation

Position the upper frame assembly P#(A1114) above the lower mount tubes as shown in Figure 2-6. Slide the upper frame assembly down onto the lower frame tubes and secure using (2) clevis pins P#(K0133) and (2) hair pin clips P#(K0088).

Figure 2-6

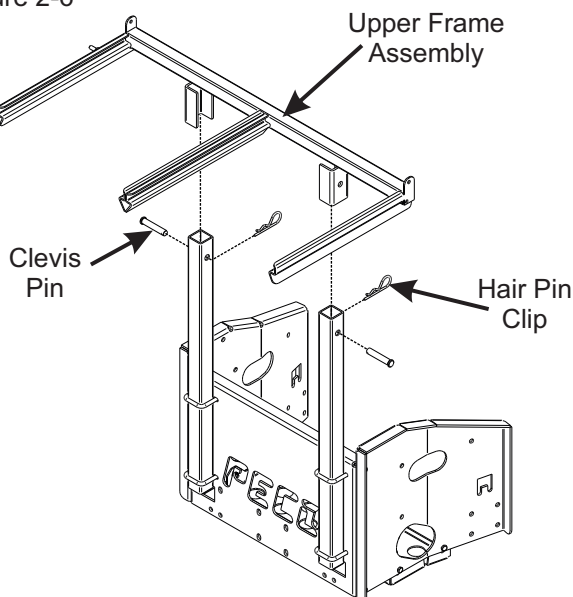

2-7 Top Assembly To Upper Frame Assembly Installation

Position the top assembly P#(A1028) above the upper frame assembly as shown in Figure 2-7. Fasten the top assembly to the upper frame assembly using (2) 5/16"-18 x 2-1/2" HHCS P#(K0125), (2) 1/4" Flat Washer P#(K0037), and (2) 5/16"-18 nylon flange locknuts P#(K2516). Leave the locknuts slightly loose, to allow the top assembly to open and close easily. Refer to Figure 2-7 for hardware location.

Insert the Inlet P#(V0019) into the hole on the top assembly from the inside and then snap the inlet into place. The inlet should pivot freely about the hole.

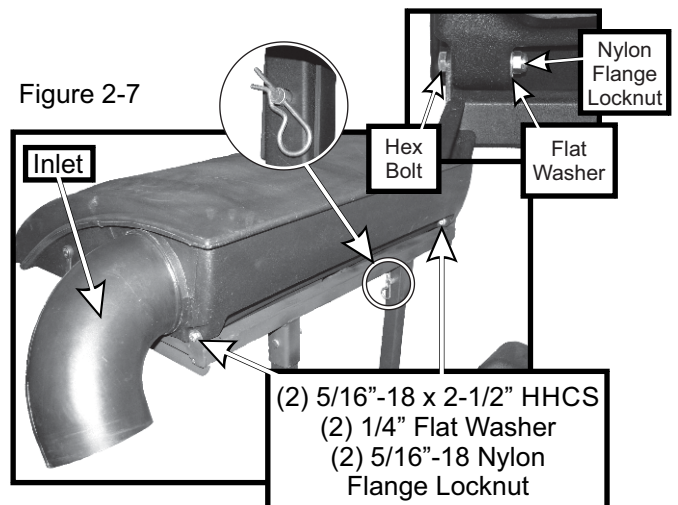

2-8 Hinge Kit Assembly Installation

Assemble the hinge kit as shown in Figure 2-8, using (2) 5/16"-18 x 1" HHCS P#(K1154), (3) 5/16"-18 nylon flange locknuts P#(K2516), (5) 1/4" flat washers P#(K0037) and (2) swing arm brackets P#(ZT-0004). Place (1) vinyl cap P#(J0289) on the end of the hex bolts as shown in Figure 2-8. Leave the nuts loose enough to allow fluid movement of the top when opening and closing. When opened, the top should rest on the middle joint of the hinge allowing it to remain up.

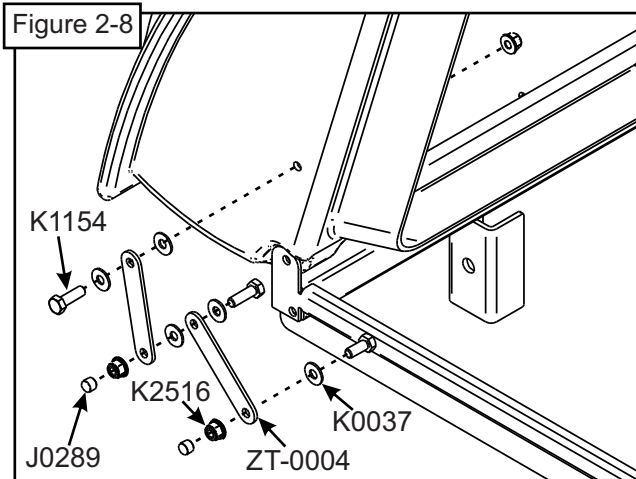

2-9 Exhaust Diverter Installation

Insert the exhaust deflector P#(J0251) onto the end of the muffler. Orientate the exhaust diverter to exhaust towards the rear of the mower, slightly downward to avoid burning the cloth bags or the grass. Secure the exhaust diverter with (1) exhaust clamp kit P#(X1046). Refer to Figure 2-9.

Figure 2-9

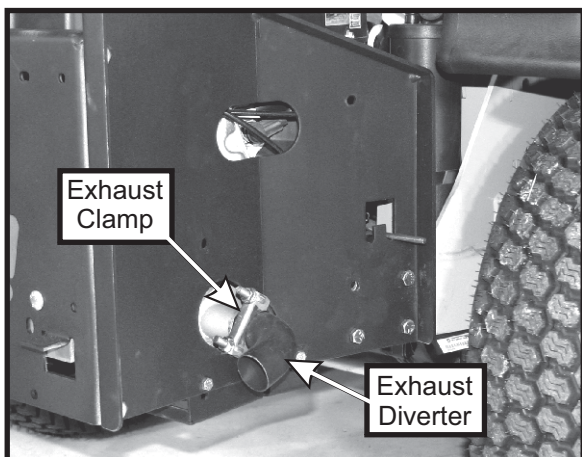

2-10 PTO Mount Plate Component Installation

Secure the left PTO mount plate P#(B0731) to the right lower frame plate using (2) 3/8"-16 x 1" HHCS P#(K1191) and (2) 3/8"-16 nylon flange locknuts P#(K2038). Leave the hardware slightly loose until the PTO stop plate has been installed. Refer to Figure 2-10a.

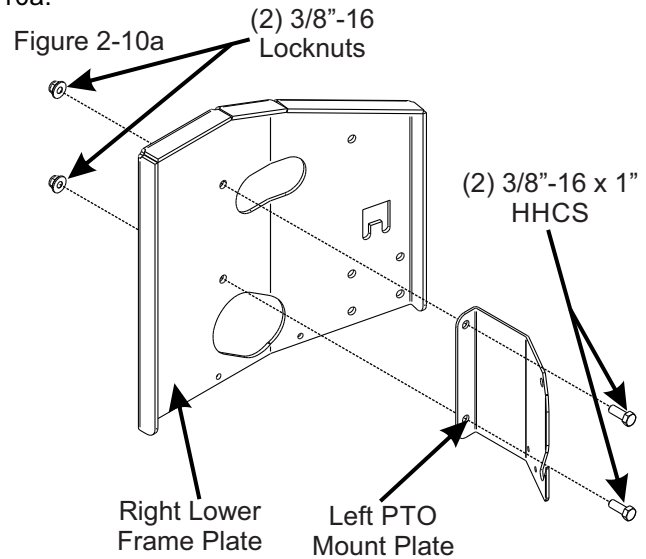

Secure the right PTO mount plate P#(B0732) to the right lower frame plate using (2) 3/8"-16 x 1" HHCS P#(K1191) and (2) 3/8"-16 nylon flange locknuts P#(K2038). Leave the hardware slightly loose until the PTO stop plate has been installed. Refer to Figure 2-10b.

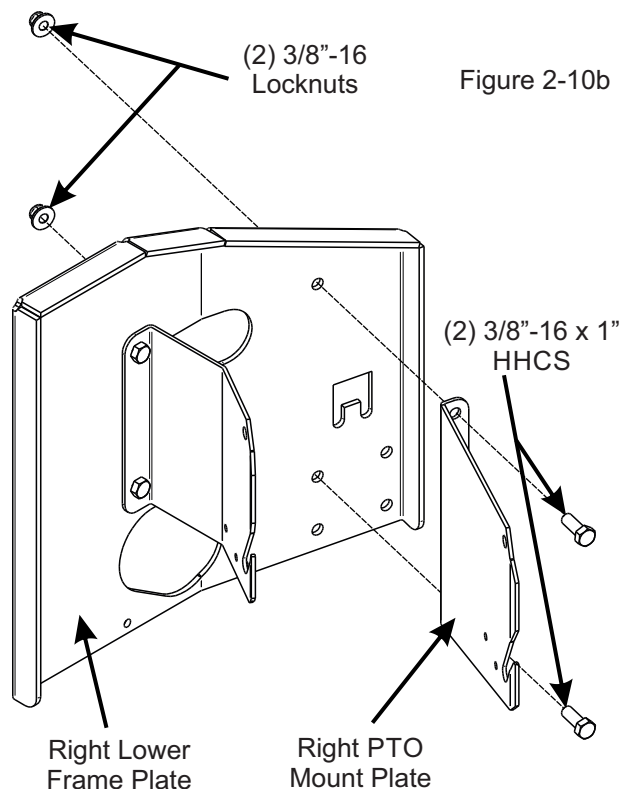

2-10 PTO Mount Plate Component Installation Continued...

Secure the PTO stop plate P#(B0733) to the left and right PTO mount plates using (4) 1/4"-20 x 3/4" HHCS P#(K1222) and (4) 1/4"-20 nylon flange locknuts P#(K2014). With the stop plate secured, tighten all PTO mount plate component hardware at this time. Refer to Figure 2-11c.

Figure 2-11c

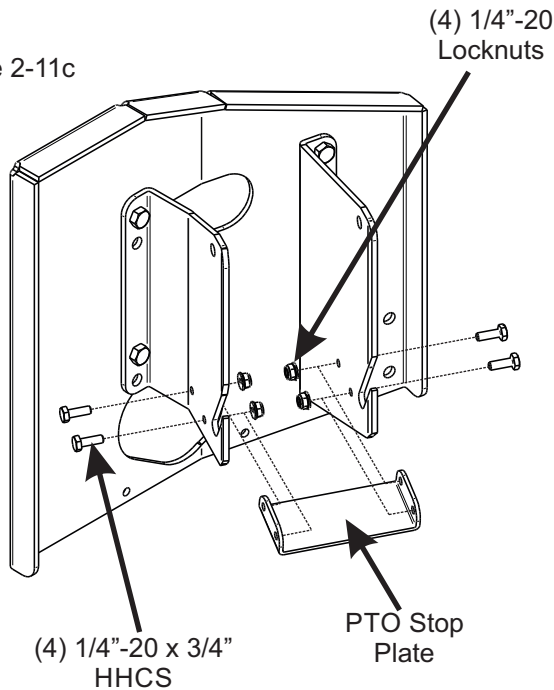
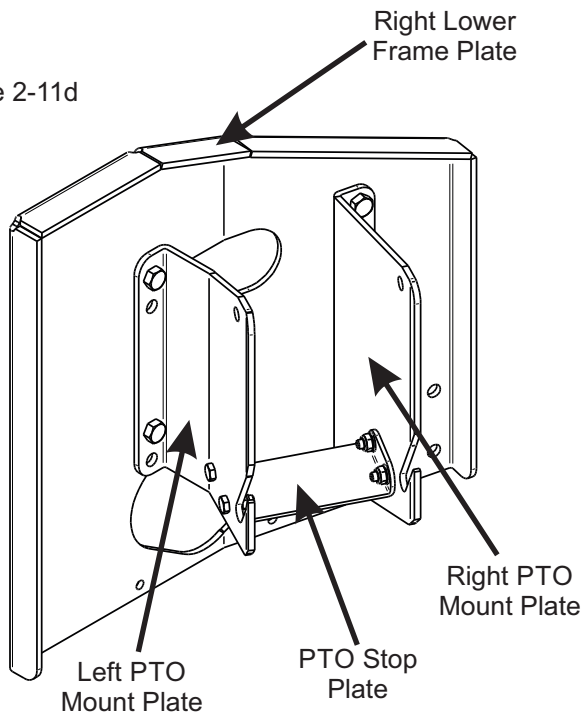

Figure 2-11d shows the complete PTO mount plate assembly as it should be assembled on your mower.

Figure 2-11d



2-11 PTO Assembly Installation

Insert the PTO assembly P#(A1840) into the lower PTO mount assembly as shown in Figure 2-11. Remove the pulley guard for preparation of the belt installation.

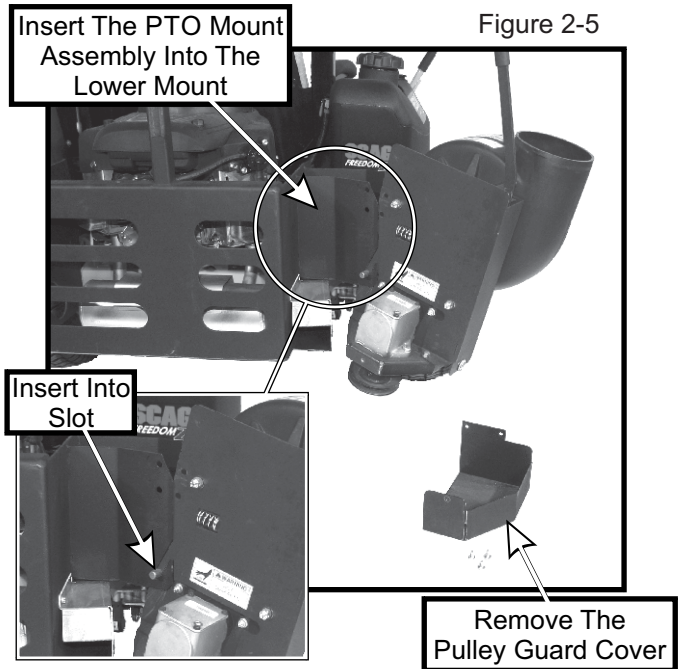

2-12 Belt Installation/Removal and Adjustment

Installation/Removal:

(Step 1) Loosen the (4) 5/16"-18 x 3/4" HHCS P#(K1153) that secure the gear box to the PTO assembly. There are (2) 5/16"-18 x 3/4" HHCS on the rear side of the PTO assembly where the gearbox is located (Figure 2-11a), and there are (2) 5-16"-18 x 3/4" HHCS on the front side of the PTO assembly underneath the blower housing. See Figure 2-6b.

(Step 2) Loosen the adjustment bolt (1) 3/8"-16 x 2" hex bolt P#(K0348) located on the side of the PTO assembly. See Figure 2-11b.

(Step 3) Slide the gearbox towards the mower until there is enough clearance for the kevlar belt A57K P#(M0256) to slide over both the engine and gearbox pulleys. See Figure 2-11c.

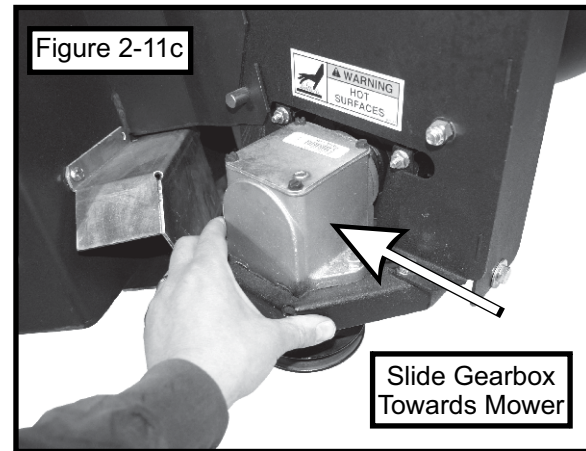

(Step 4) Wrap the kevlar belt around both pulleys.

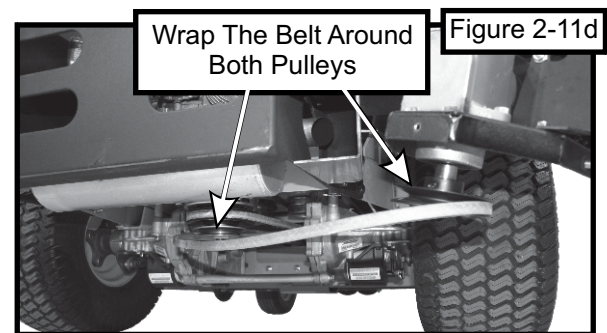

(Step 5) Secure the PTO assembly to the lower PTO mount assembly using (1) PTO assembly mount pin P#(B0274) and (1) hair pin clip P#(K0086). See Figure 2-11e.

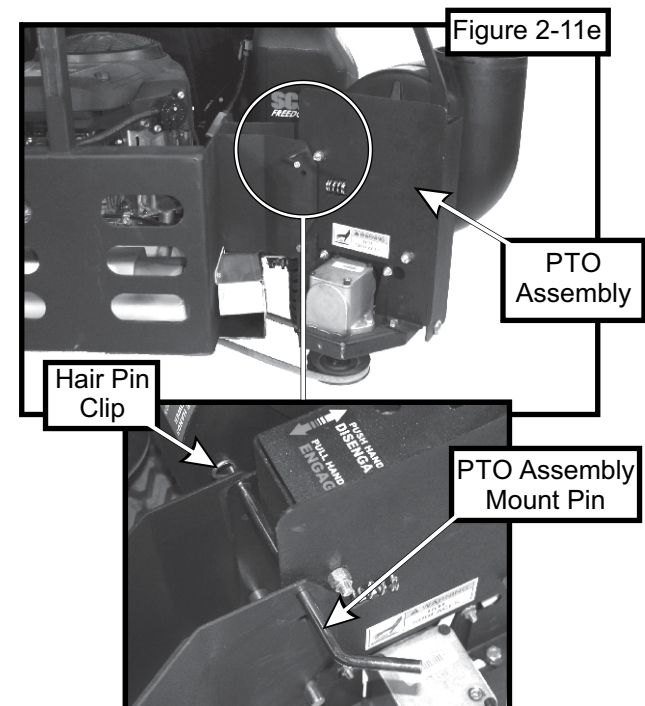
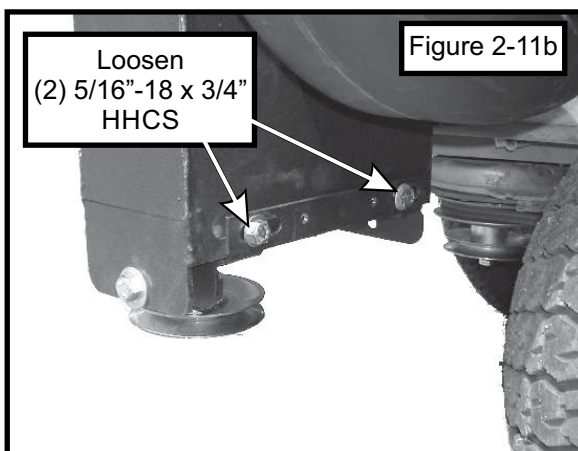
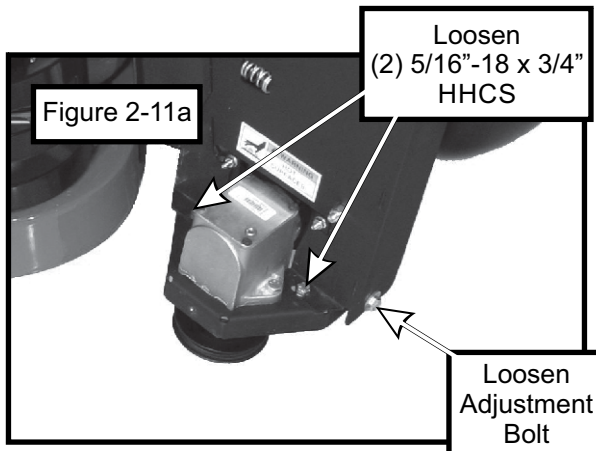

2-12 Belt Installation/Removal/Adjustment Cont.

Adjustment: To adjust the belt tension, turn the adjustment bolt clockwise until there is 1" of deflection, with 10-11lbs of pressure applied to the center of the belt. When the belt has the proper tension, tighten the (4) 5/16"-18 x 3/4" HHCS that secure the gear box to the PTO assembly. Replace the belt guard and (3) 1/4"-20 x 1/2" HHSTS. Refer to the Figures below.

Figure 2-12f

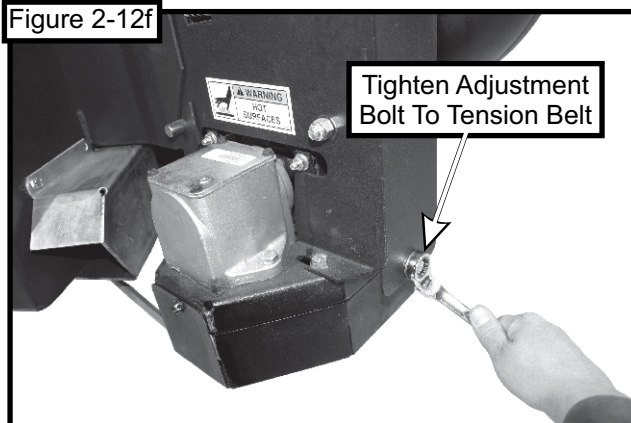

Figure 2-12g

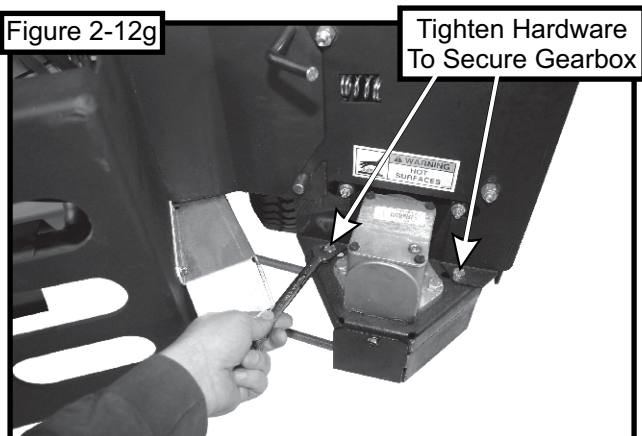
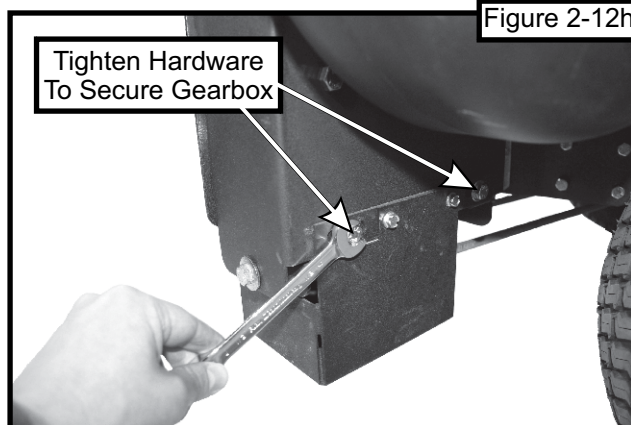
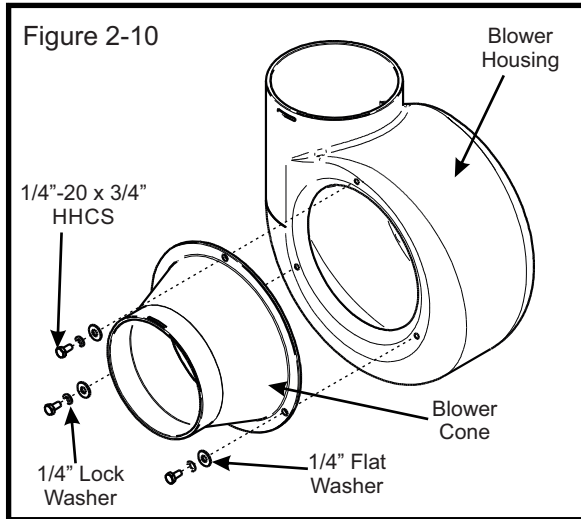

Figure 2-12h



2-10 Blower Cone Installation/Removal

Fasten the blower cone P#(V0016) to the blower housing located on the PTO assembly. Use (3) 1/4"-20 x 3/4" HHCS P#(K1222), (3) 1/4" lock washers P#(K0039), and (3) 1/4" flat washers P#(K0037) to secure the blower cone to the blower housing. Refer to Figure 2-10 for reference.



2-14 Impeller Blade Removal/Replacement

To Remove: To access the impeller blade, remove the blower cone P#(V0016) and blower cone hardware from the blower housing. Remove the 5/16"-24 x 7/8" left hand thread hex bolt P#(K1171) and washer P#(K1446). Insert (1) 1/2"-13 x 1" hex bolt into the threads on the impeller blade. Tighten the hex bolt until the impeller blade breaks free from the PTO shaft. Remove the impeller blade assembly P#(A1839) from the PTO shaft. Remove the key P#(J0254) from the PTO shaft.

To Replace: Insert the key P#(J0254) into the keyway slot on the PTO shaft. Align the keyway slot on the bushing of the impeller blade assembly with the key on the PTO shaft and insert the impeller blade onto the PTO shaft. Secure the impeller blade with (1) 5/16"-24 x 7/8" left hand thread hex bolt P#(K1171) and (1) washer P#(K1446). Replace the blower cone P#(V0016) and blower cone hardware. Refer to Figure 2-14 for reference.

Figure 2-14

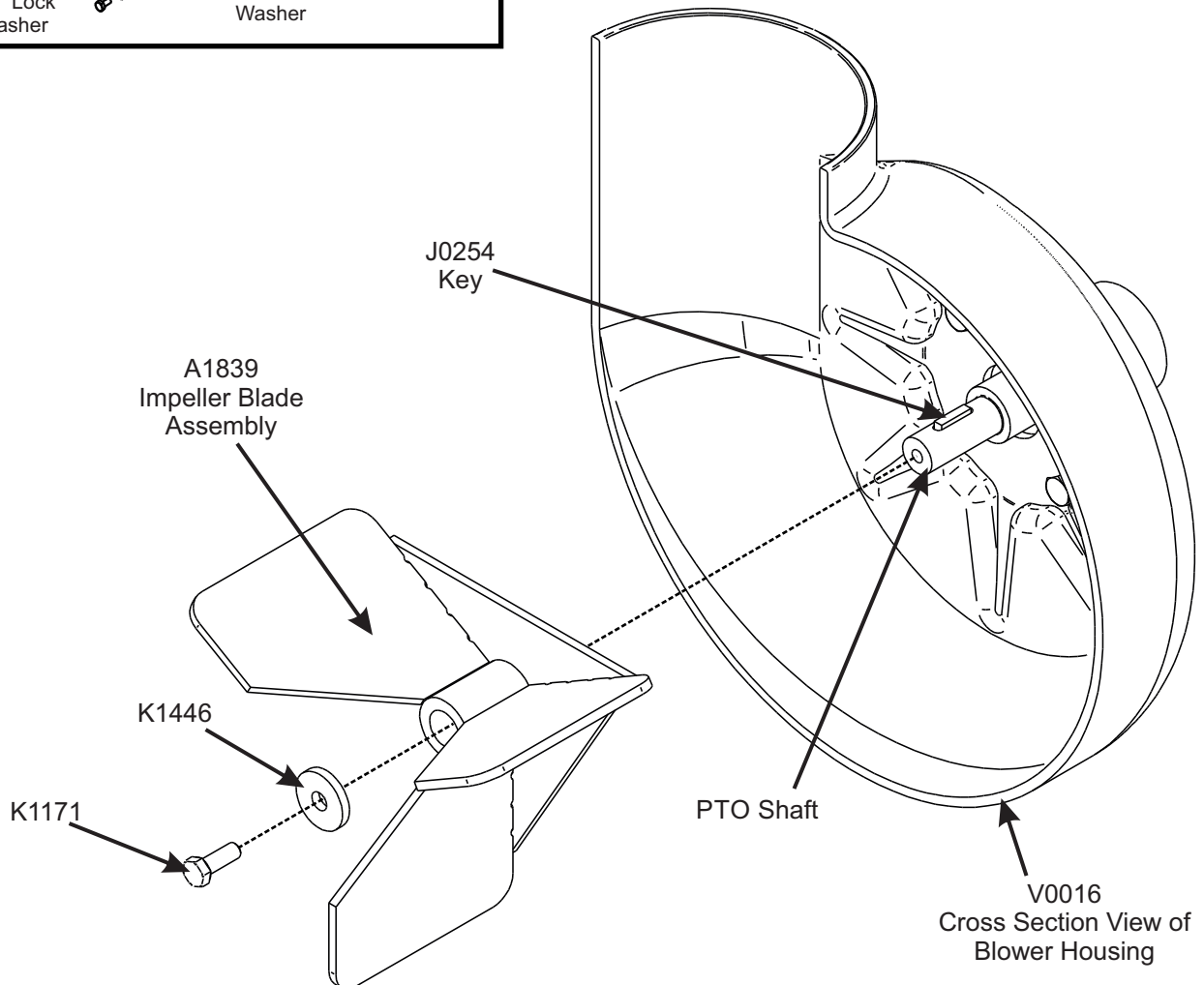

2-15 Boot To Mower Deck Installation

Fasten the boot plate P#(B0577) to the boot P#(V0027) for 48" decks or P#(V0028) for 52" decks, using (3) 5/16"-18 x 1" carriage bolts P#(K1144), (3) 5/16"-18 nylon flange locknuts P#(K2516). Insert the carriage bolts from inside the boot, so the threads are on the outside. This will prevent grass clippings from collecting on the threads. Refer to Figure 2-15a.

Secure the boot plate to the mower deck using (1) boot rod P#(B4331) and (1) hair pin clip P#(K0099). See Figure 2-15b.

Figure 2-15a

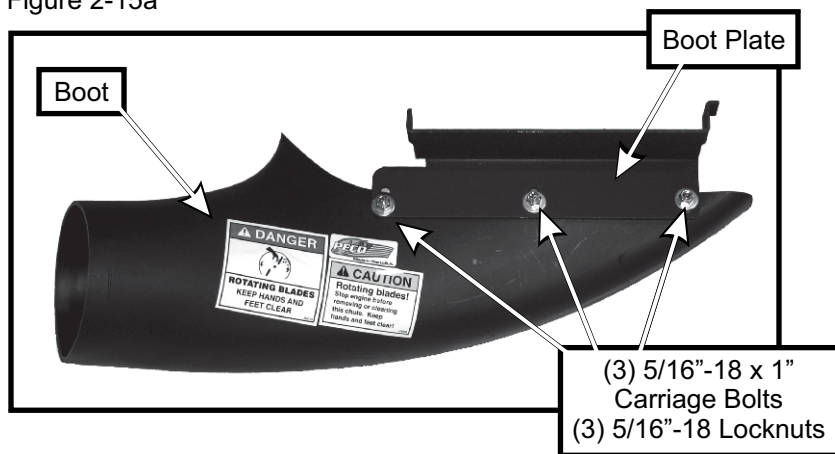
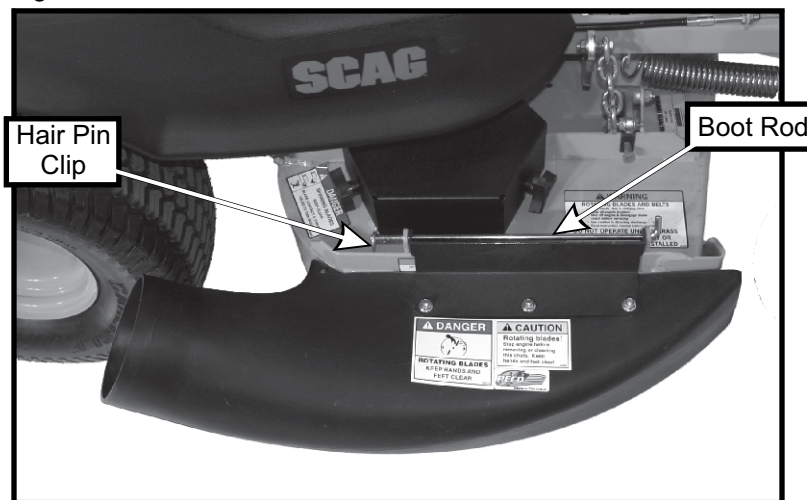

Figure 2-15b



2-16 Length Of Hose Adjustment

The hoses in steps 2-17 and 2-18 must be cut to fit your machine. Do not cut the hoses until you have tried to fit them on your machine. Remember that the hoses have to be long enough to adjust for the blower assembly's movement as well as allow for enough clamping surface between the inlet, blower assembly and the deck boot.

2-17 Upper Hose Installation

Slide a hose clamp P#(J0060) over both ends of the upper hose. Then slide one end of the upper hose onto the inlet. Make sure there is about a two-inch overlap between the hose end and the container inlet. Proceed to slide the opposite end of the upper hose onto the outlet of the blower assembly. See Figure 2-17 for details. Tighten the hose clamps.

2-18 Lower Hose To Blower Cone Installation

Slide a hose clamp P#(J0060) over both ends of the 6" lower hose. Then proceed to slide the lower hose onto the blower cone. Tighten the hose clamp. See Figure 2-17 for details.

2-19 Lower Hose To Boot Installation

Take the unattached end of the lower hose and slide it over the circular end of the boot. Use the hose clamp P#(J0060) to secure the hose to the boot.

NOTE: Before tightening the hose clamp, rotate the lower hose counter clockwise (see Figure 2-17) approximately 1" and then tighten the clamp. This will hold the bottom edge of the boot tight to the mower deck.

2-20 Weight Kit Installation

Secure the weight bracket P#(B0576) to the front frame of the mower using (2) 1/2"-13 x 1" HHCS P#(K1231) and (2) 1/2"-13 nyloc nuts P#(K1247). Secure the weight to the weight bracket using (2) 1/2"-13 U-Bolts P#(K0331) and (4) 1/2"-13 nyloc nuts. See Figure 2-20.

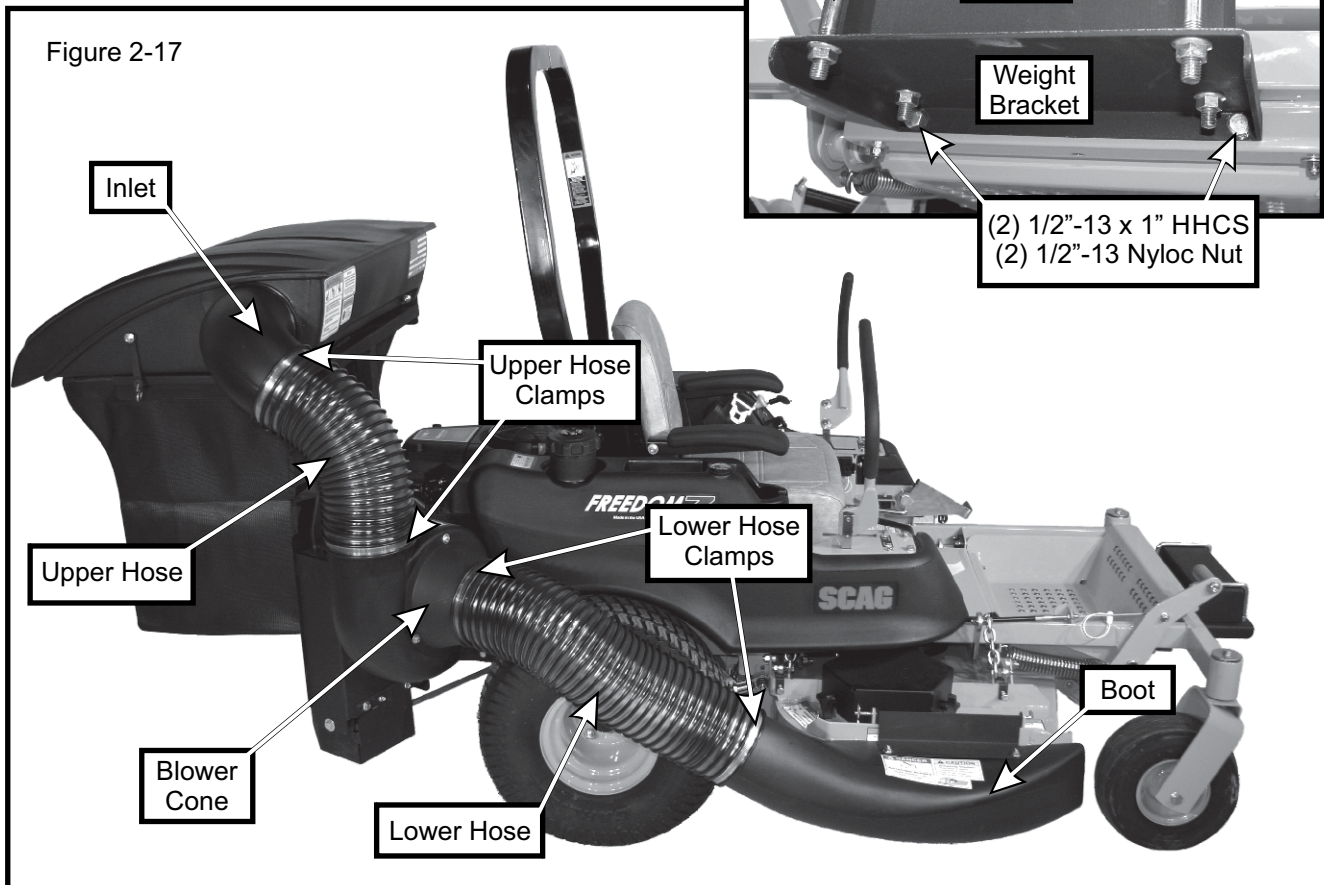

2-21 Installation/Removal Of Collection Bags

To install the bag P#(G0002) onto the bag ring P#(B0227), first make sure the bag ring end caps P#(J0274) are fastened to the bag ring. Place the seam openings of the bag onto the bag ring openings and turn the bag until the slot bracket in the bag ring is protruding from the opening in the bag (Figure 2-21a). Do this for both bags.

Install the completed assemblies onto the support frame and close the plastic top. To secure the plastic top while in use, fasten the rubber strap with S hook to the right pivot side rail as shown in Figure 2-21b.

To empty the bag, remove the bag and bag ring by sliding the bag rearward. Grasp the loop on the bottom of the bag, turn it upside down and empty the collected debris (Figure 2-21c). Repeat for the other bag. Reinstall both bags, line with plastic bags if desired, close the plastic top and reattach the rubber strap with 'S' hook.

Plastic lawn and leaf bags, 33 gallon size, may be used inside the cloth bags. Be sure to leave enough plastic bag hanging over the frame so the plastic bags can be twist tied before emptying (Figure 2-21d).

Figure 2-21a

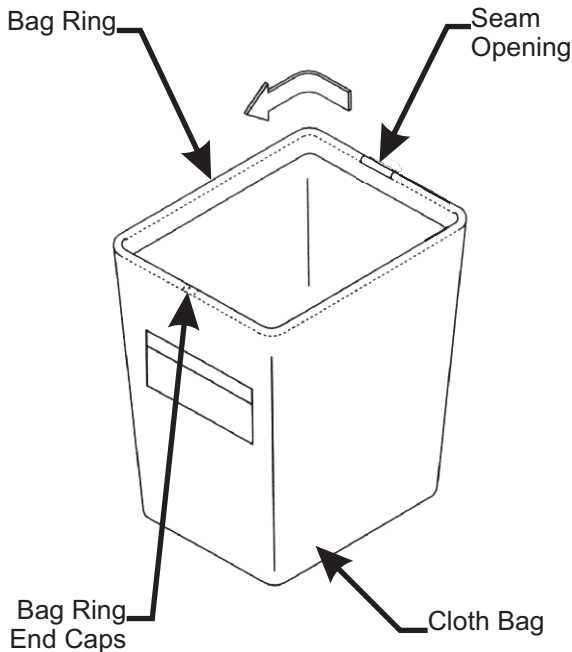

Figure 2-21b

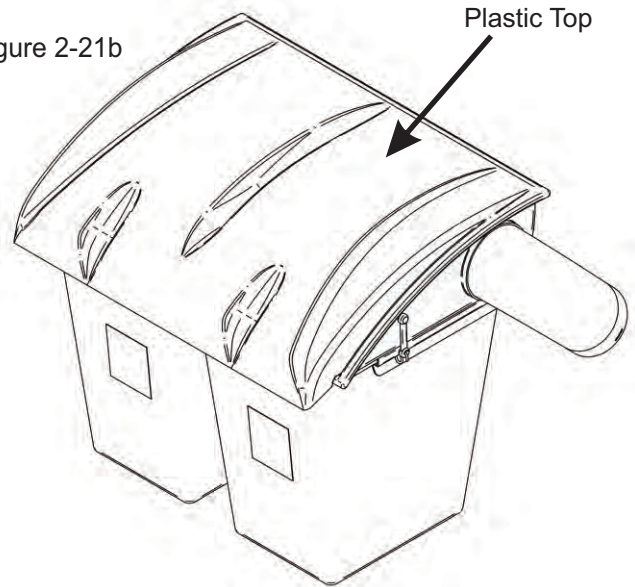

Figure 2-21c

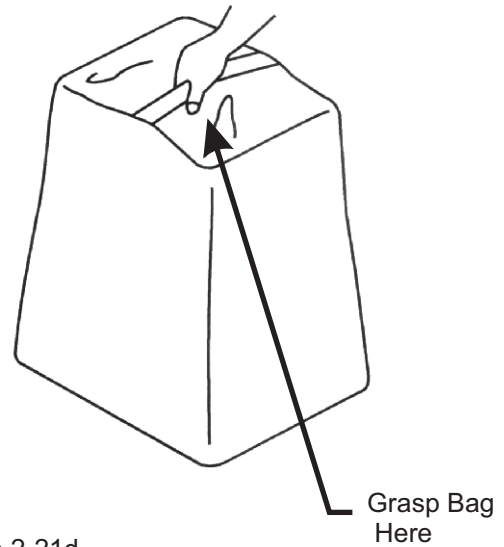
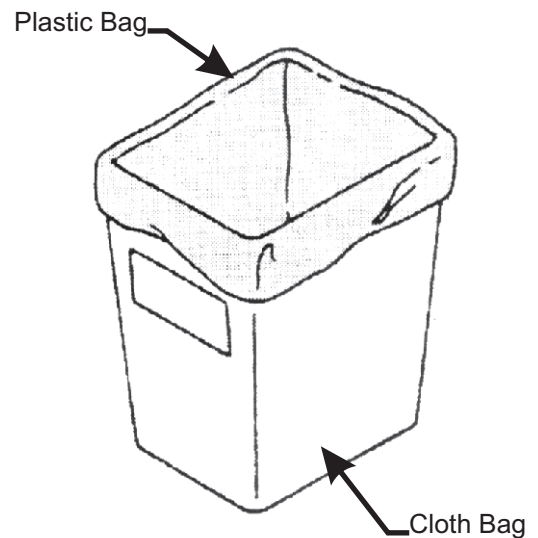

Figure 2-21d



SECTION III OPERATING INSTRUCTIONS

3-1 General Safety

Only qualified people familiar with this operator's manual and the mower's operator's manual should operate this machine.

3-2 Operation And Tips On Mowing

- A. Perform BEFORE EACH USE the maintenance list in paragraph 4-1.
- B. Start mower.
- C. With the mower at high idle speed, engage the mower deck.
- D. While seated in the operator's seat, pull the engagement handle of the PTO assembly towards the operator's seat until the handle slides into position in the retaining slot. With the PTO assembly engaged, you can proceed to operate the control levers of the mower.

NOTE: If the collection system does not appear to be collecting the grass clippings, disengage the deck and PTO assembly (Section 3-3), then, engage the parking brake and turn the mower off. Check upper and lower hoses for any clogs.

To obtain the maximum effectiveness from your collection system, the tips listed below should be followed:

- * Watch your speed- Normal conditions will allow a speed of up to approximately 4 mph, but thick, heavy damp conditions will require reduced ground speed.
- * Mow with sharp blades- A sharp blade cuts cleaner.
- * Wet grass and leaves will decrease effectiveness and will increase horsepower requirements.
- * Mow at higher cutting heights- Remove and mulch no more than 2" of grass length with each mowing. (Experts recommend not cutting off more than 1/3 of the grass blade length at any given time.)
- * Mow twice, at different height settings, (high, then low), if grass is extra tall.
- * Remember that horsepower requirements will vary with the mowing conditions such as type and height of turf grass, moisture content, amount of leaves, whether the terrain is flat or hilly, etc.

3-3 Disengagement Of The PTO Assembly

A. To disengage the PTO assembly, slide the engagement handle out of the retaining slot and push the engagement handle away from the operator's seat.

WARNING: The PTO assembly blades will continue to spin. DO NOT TOUCH the PTO assembly, pulleys, or the belt until the tractor is turned off. DO NOT adjust the belt tension until the mower is turned off. Refer to section 2-12 of the manual.

3-4 Unloading The Collection System

NOTE: To determine when the collection bags are full, follow the following steps:

- A. Stop the forward movement of the mower.
- B. Disengage the mower deck.
- C. Disengage the PTO assembly.
- D. Engage the parking brake.
- E. Once the parking brake has been engaged, then and only then, walk behind the mower and check the collection bags by first unhooking the rubber strap with S hook that secures the plastic top, then lift the plastic hood. Load in bags should not exceed the height of the installed bag.
- F. To remove the bags from the frame slide bags out and turn bags over to deposit clippings.
- G. Slide empty bags back onto the frame and secure plastic top with the rubber strap with 'S' hook.

NOTE: Do not allow collection bags to become over-filled as potential damage may occur to your equipment. Also, be sure to clean the hood screen as needed.

SECTION IV MAINTENANCE

4-1 Maintenance Checklist

Before each use:

1. Check blades and spindles to be sure that no foreign objects, such as wire or steel strapping bands, are wrapped around them.
2. Inspect blades for wear. Replace if necessary. If it is necessary to sharpen the blades, remove the blades from the spindles before sharpening. DO NOT sharpen blades while still attached to the mower.

3. Make sure all shields are in place and in good condition. Repair or replace any missing or damaged shields.
4. Perform lubrication per paragraph 4-2.
5. Listen for abnormal sounds, which might indicate loose parts, damaged bearings, or other damage. Correct any deficiency before continuing operation.
6. With the engine off, engage the blower assembly. Check the belt tension and inspect the pulley belt for cracks or tears.
7. Check for wear or deterioration of the upper or lower hoses. If there are any portions of the hose that have been torn or worn through, replace immediately.

After Each Use:

1. Clean all debris from machine especially from the container, underneath the belt shields, and safety decals. Replace any missing or illegible decals.
2. Inspect the unit for worn or damaged components. Repair or replace before the next use. Any replacement component installed during repair shall include the component's current safety decal specified by the manufacturers to be affixed to the component.
3. Check belt for proper tension.

4-2 Lubrication

NOTE: Use only white lithium based grease for lubrication of the shaft on the blower assembly.

1. On initial use: Grease the fitting on the blower shaft.
2. Every 25 hours of use: Re-grease the grease fitting.
3. Every 200 hours of use: Check oil levels in gear box. Oil in gear box should cover the gears. If not, fill using an EP90 weight oil. 6oz. will fill the gear box from empty.

SECTION V PARTS AND SERVICE

5-1 Parts And Service Information

Collection system owners should record the name and telephone number of their Service Center. Your Service Center will be happy to supply replacement parts, accessories, and do any service or repairs to your collection system. If for any reason your Service Center is unable to service your collection system or supply replacement parts, contact PECO Inc. and include the following information on the chart below.

THE SERIAL NUMBER PLATE
IS LOCATED ON THE TOP
ASSEMBLY

WRITE THE MODEL AND
SERIAL NUMBER IN THE
BOX TO THE LEFT
FOR FUTURE REFERENCE.

Unit Model Number: _____
Unit Engine Size: _____
Unit Serial Number: _____
Date of purchase: ____/____/_____
Dealer/Distributor Name: _____
Address: _____ **State:** _____ **Zip:** _____
Phone Number: _____

PECO Inc.
10 Walden Drive | Arden, NC | 28704
Phone: 1-800-438-5823
Fax: (828)684-0858
E-Mail: peco@lawnvac.com

Unit Model #: 37120901

Mower: Scag

Owner's Manual: Q0456

Mower Type: Freedom Z

Engine Type:

Deck Size: 48"

Vac Type: 9 Cu. Ft. Pro 2+ Bagger

Deck Type:

Drive Type: Rear PTO Drive (3-Blade)

Revision 2: Updated To Fit 2015 Mowers 5/21/2015

Fits Year[s]: 2010-2015

A1902 Vac Kit

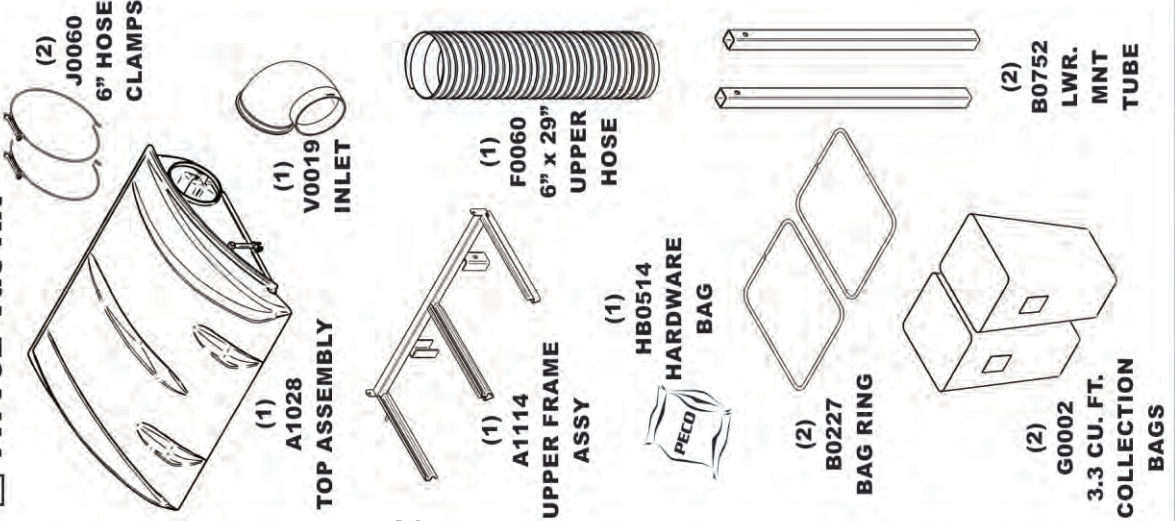

A1153 48" BAFFLE KIT

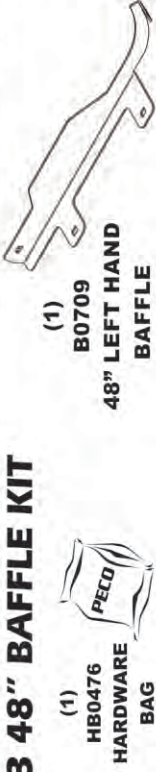

A1903 Mount Kit

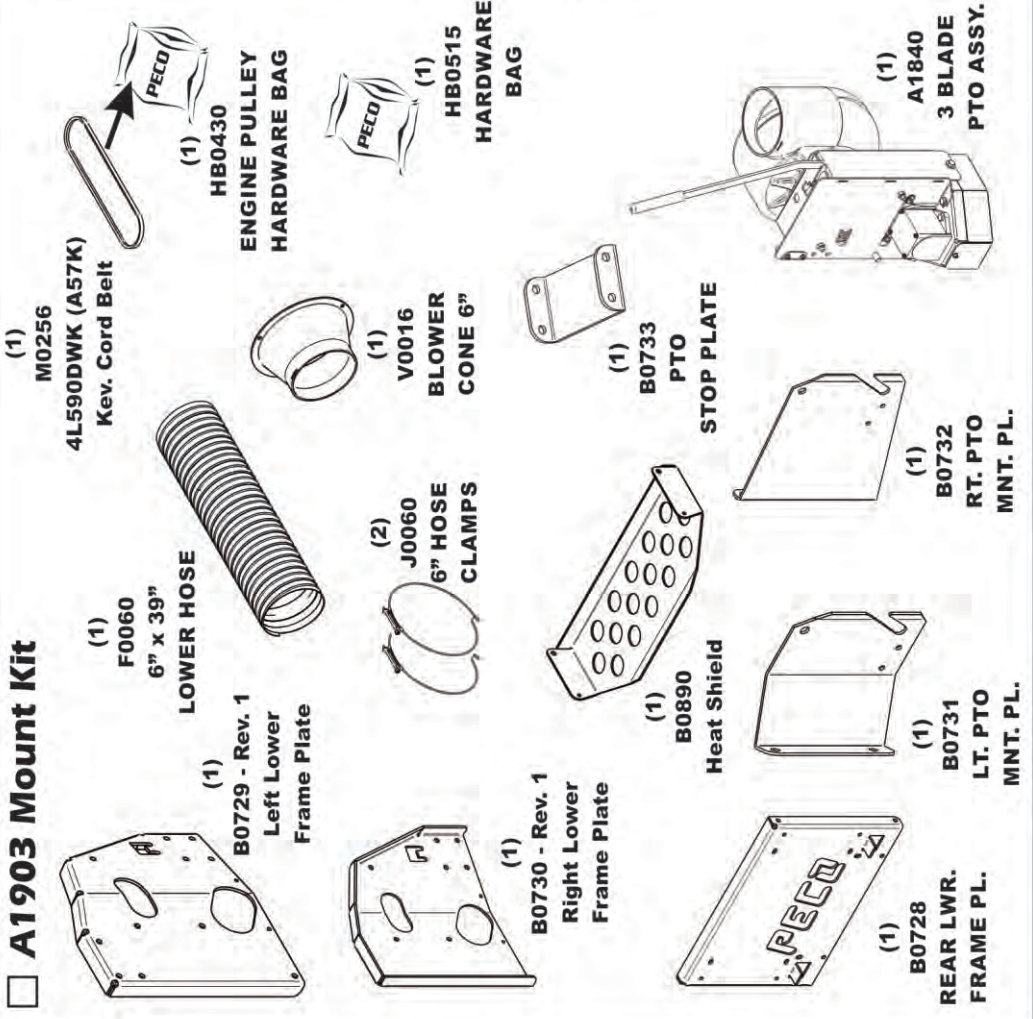

A1790 Boot Kit

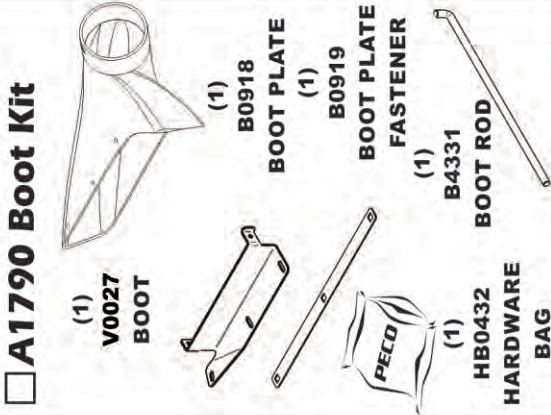

A1791 Weight Kit

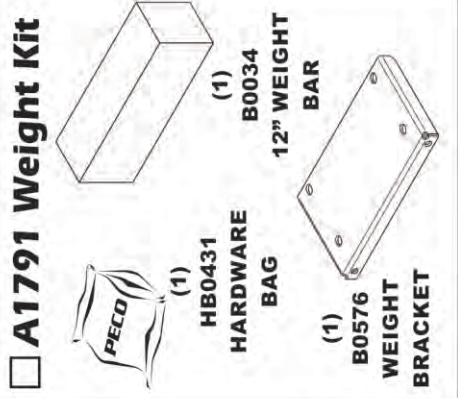

Unit Model #: 37120902

Mower: Scag

Owner's Manual: Q0456

Mower Type: Freedom Z

Engine Type: KW FS691V-AS13

Deck Size: 52"

Vac Type: 9 Cu. Ft. Pro 2 + Bagger

Deck Type:

Drive Type: Rear PTO Drive (3-Blade)

Revision 2: Updated To Fit 2015 Mowers 5/21/2015

Fits Year(s): 2010-2015



☐ A1902 Vac Kit

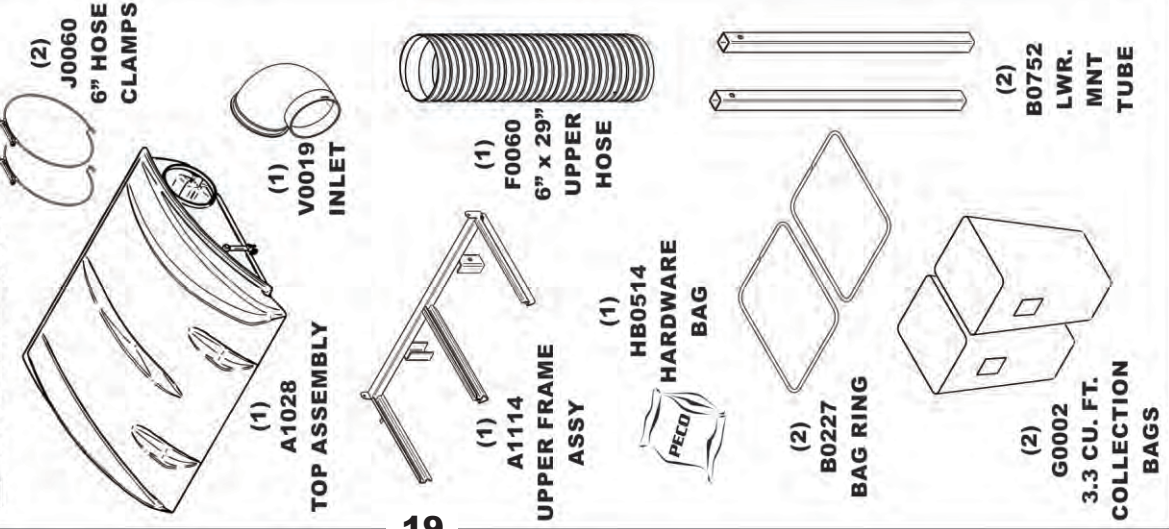

☐ A1151 52" BAFFLE KIT

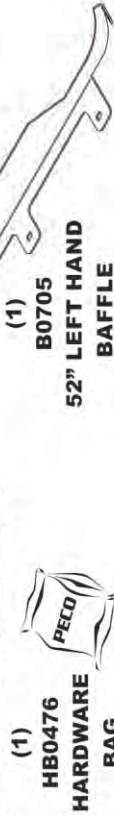

☐ A1934 Mount Kit

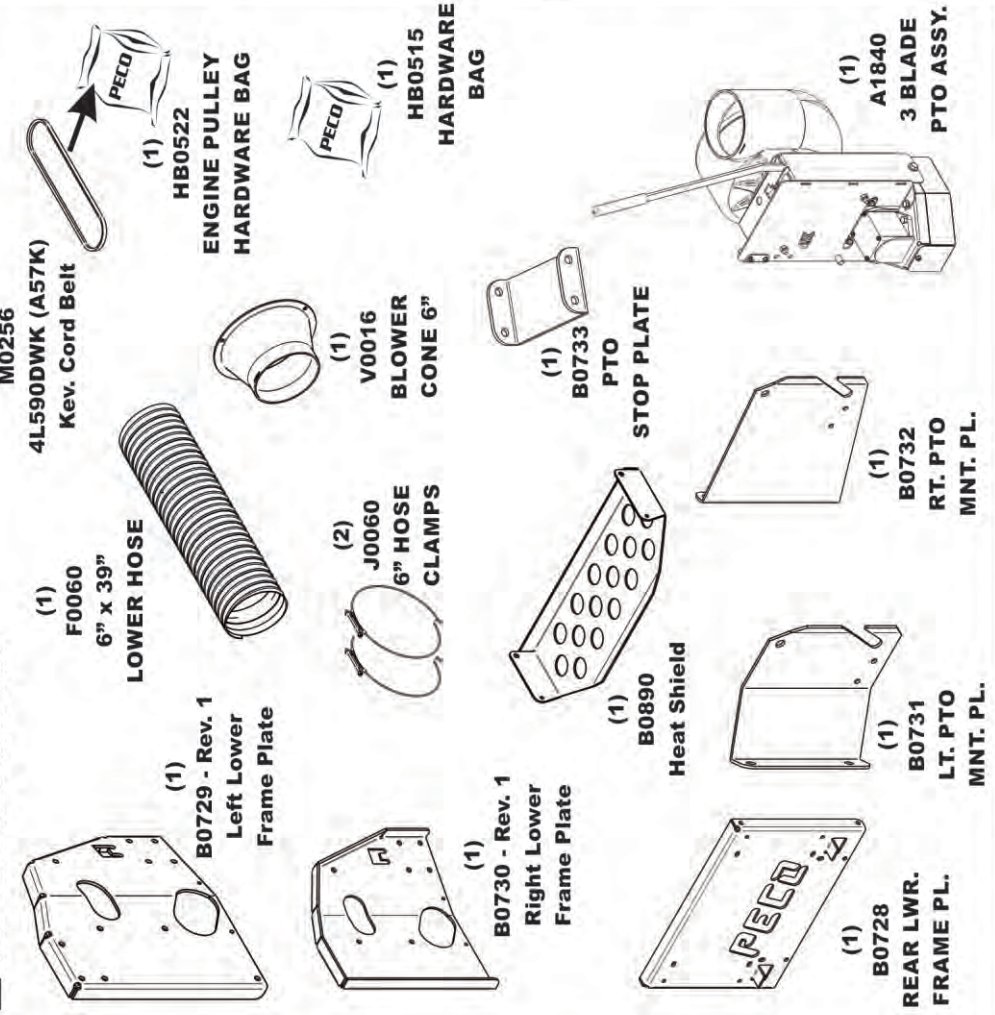

☐ A1796 Boot Kit

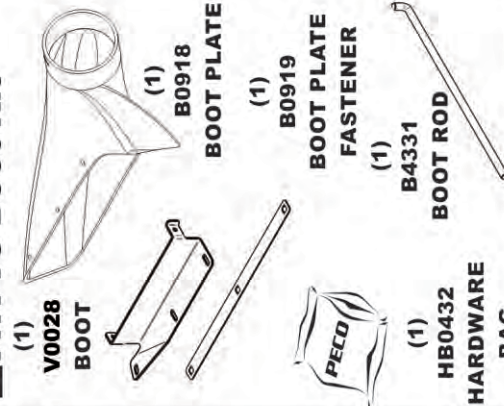

☐ A1791 Weight Kit

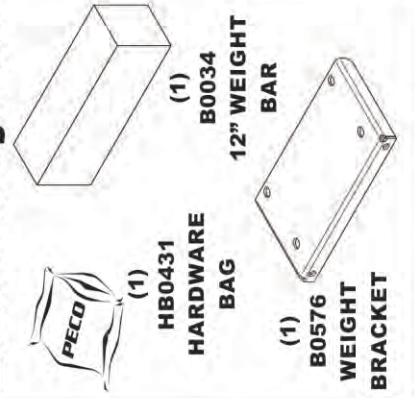

**A1028 TOP ASSEMBLY
A1114 UPPER FRAME ASSEMBLY
EXPLODED PARTS VIEW**

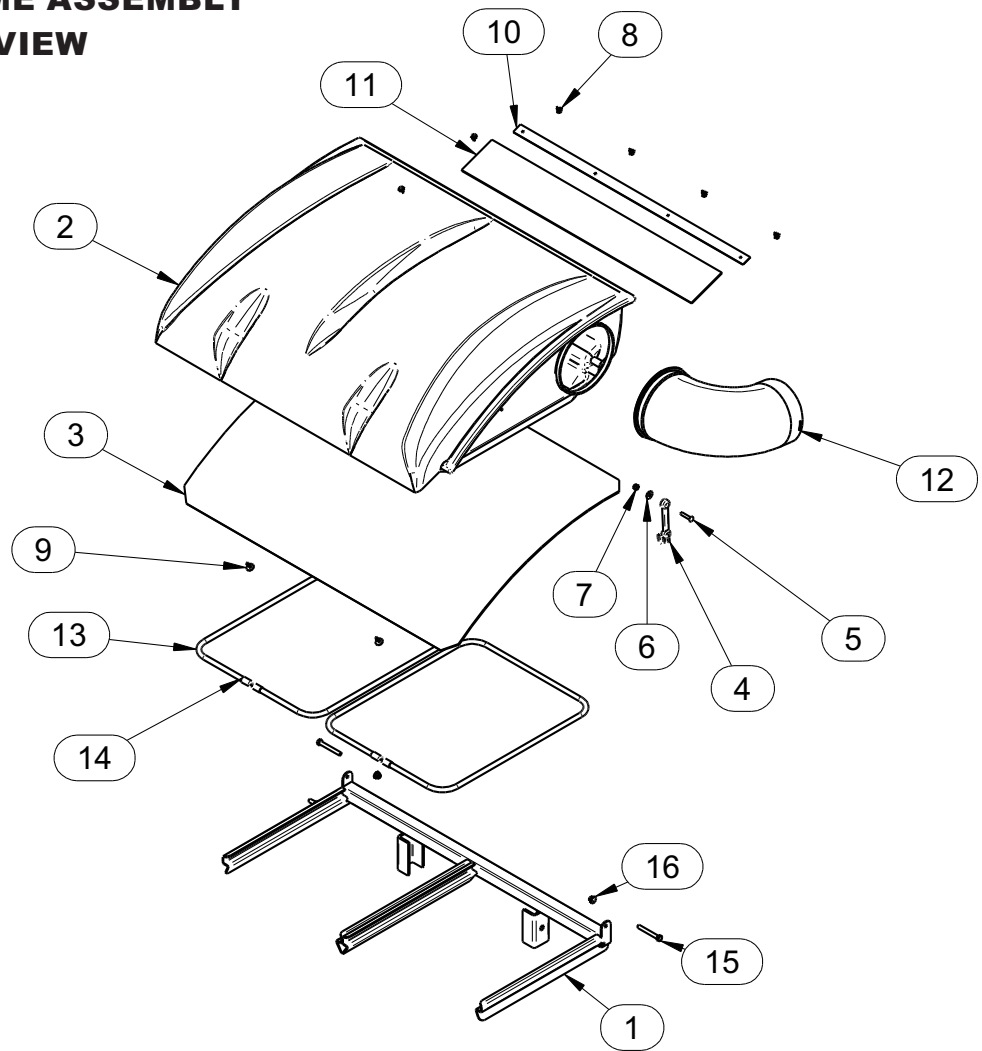

Item #	Part #	Desc.	Qty.
1	A1114	2 BAG FRAME ASSY	1
2	V0017	PRO 2 BAGGER TOP	1
3	V0018	Black Plastic Screen	1
4	J4009	SHORT RUBBER STRAP W/ S HOOK	1
5	K1030	1/4\"-20 x 1-1/4\" CARRIAGE BOLT	1
6	K0037	1/4\" FLAT WASHER .75 OD x .314 ID x .060 T	1
7	k1128	1/4\"-20 NYLOC NUT	1
8	K0114	BLACK PLASTIC RIVET	6
9	K1265	BLACK PANEL RETAINER	2
10	C0067	DUST GUARD BRACE	1
11	V1117	DUST GUARD	1
12	V0019	INLET	1
13	b0227	BAG RING	2
14	j0274	BAG RING END CAP	4
15	K0125	5/16\"-18 x 2-1/2\" ALL THREAD HHCS	2
16	K2516	5/16\"-18 Nylon Flange Locknut	2

A1840 PTO ASSEMBLY

EXPLODED PARTS VIEW DESCRIPTION

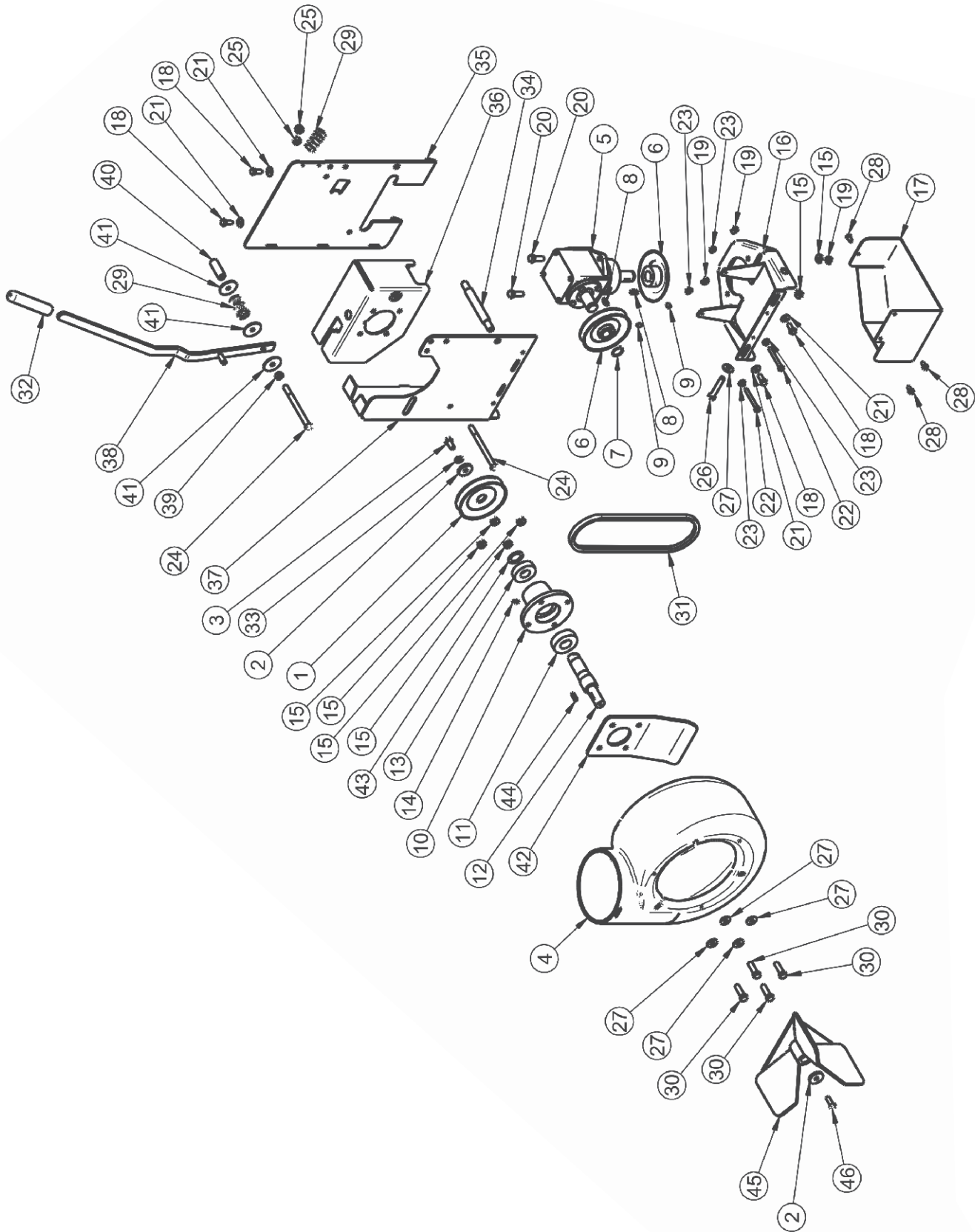

**A1840 PTO ASSEMBLY
EXPLODED PARTS VIEW**

Item #	Doc #	Title	Qty
1	M0266	'A' PULLEY FOR DECK DRIVE PTO	1
2	K1446	1.187 OD x .380 ID x .187 WASHER	2
3	k1190	3/8"-16 x 3/4" HHCS	1
4	V0015	BLOWER HSG.	1
5	A0431	GEAR BOX	1
6	A0498	PULLEY ASSY. FOR GEAR BOX	2
7	K0360	7/8" SNAP RING	2
8	J0272	#9 WOODRUFF KEY	2
9	K0035	5/16-18 SET SCREW	2
10	E0015	PTO SHAFT HOUSING	1
11	n0147	BEARING 2.0472 OD, 0.9843 ID, 0.5906 W (6205RS PEER)	1
12	B0460	PTO SHAFT	1
13	N0165	BEARING	1
14	J0801	1/4"-28 ZIRC FITTING	1
15	K1215	3/8"-16 FLANGE NUT	7
16	B0466	BASE PL.	1
17	B0478	GEAR BOX PULLEY GUARD	1
18	K1153	5/16"-18 x 3/4" HHCS	4
19	K1178	5/16"-18 FLANGE NUT	4
20	k1191	3/8"-16 x 1" HHCS	2
21	K0037	1/4" FLAT WASHER .75 OD x .314 ID x .060 T	4
22	k1150	1/4"-20 x 2-1/4" HHCS	2
23	K1126	1/4"-20 FLANGE NUT	4
24	K1202	3/8"-16 x 4-1/2" HHCS G5	2
25	k1216	3/8"-16 NYLOC NUT	2
26	K0348	3/8"-16 x 2" ALL THREAD HHCS	1
27	k0042	5/16" FLAT WASHER .875 OD x .380 ID x .075 T	5
28	K0353	1/4"-20 x 1/2" HHSTS	3
29	J0303	SPRING	2
30	K1192	3/8"-16 x 1-1/4" HHCS	4
31	M0267	A28K KEVLAR BELT	1
32	V1151	5/8" ID x 4-3/4" BLACK HANDLE GRIP	1
33	K0048	3/8" LOCK WASHER	1
34	B0505	PTO ARM MNT. ROD	1
35	B0506	LT. PTO ARM	1
36	B0642	BLWR. MNT. BRKT.	1
37	B0643	RT PTO ARM	1
38	A1112	PTO HANDLE ASSY	1
39	B0510	SPACER BUSHING	1
40	B0511	SPACER BUSHING	1
41	K0403	WASHER 1-1/2" OD x 3/8" ID	3
42	B0739	Blower Hsg. Stiffener Pl.	1
43	K0070	Flat Washer SS	1
44	J0254	3/16" x 3/16". x 3/4" Key	1
45	A1839	3-Blade Impeller Assy.	1
46	K1171	5/16"-24 LH x 7/8" HHCS GR. 5 w/ Patch Coating	1

SAFETY DECALS

To promote safe operation, PECO Inc. supplies safety decals on all products manufactured. Damage can occur to safety decals either through shipment, use or reconditioning. Contact your local Service Center for replacement decals.



Part #: R1070
PECO Label



Part #: R2007
Never Use Hands Label

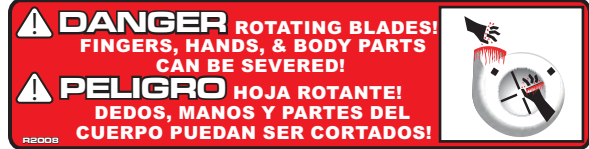

Part #: R2008
Rotating Blades Label



Part #: R1100
Engage-Disengage Label



Part #: R4037
Warning: Hot Surface Label



Part #: R1052
Small Warning: Turn Off Blower Label



Part #: R1065
Made In America Label

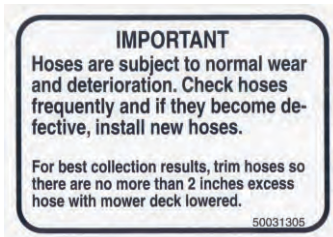

Part #: R1054
Important Label



Part #: R1069
Warning: Turn Off Blower Label



Part #: R4015
Danger: Rotating Blades Label



Part #: R1051
Warning: Hearing Protection Label



Part #: R4008
Caution: Rotating Blades Label

TORQUE SPECIFICATIONS

AMERICAN Bolt Head Markings

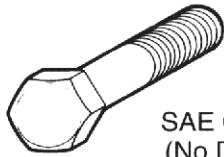

SAE Grade 2
(No Dashes)

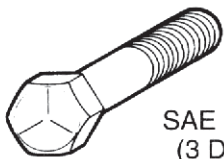

SAE Grade 5
(3 Dashes)

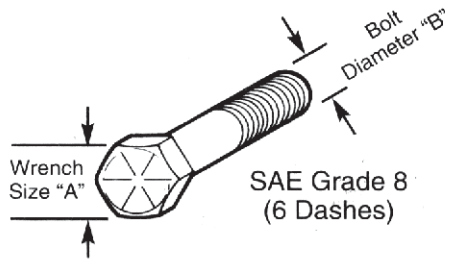

SAE Grade 8
(6 Dashes)

Recommended Torque in Foot Pounds (Newton Meters).*

WRENCH SIZE (IN.) "A"	BOLT DIAMETER (IN.) "B" AND THREAD SIZE	SAE GRADE 2	SAE GRADE 5	SAE GRADE 8
7/16	1/4 - 20 UNC	6 (7)	8 (11)	12 (16)
7/16	1/4 - 28 UNF	6 (8)	10 (13)	14 (18)
1/2	5/16 - 18 UNC	11 (15)	17 (23)	25 (33)
1/2	5/16 - 24 UNF	13 (17)	19 (26)	27 (37)
9/16	3/8 - 16 UNC	20 (27)	31 (42)	44 (60)
9/16	3/8 - 24 UNF	23 (31)	35 (47)	49 (66)
5/8	7/16 - 14 UNC	32 (43)	49 (66)	70 (95)
5/8	7/16 - 20 UNF	36 (49)	55 (75)	78 (106)
3/4	1/2 - 13 UNC	49 (66)	76 (103)	106 (144)
3/4	1/2 - 20 UNF	55 (75)	85 (115)	120 (163)
7/8	9/16 - 12 UNC	70 (95)	109 (148)	153 (207)
7/8	9/16 - 18 UNF	79 (107)	122 (165)	172 (233)
15/16	5/8 - 11 UNC	97 (131)	150 (203)	212 (287)
15/16	5/8 - 18 UNF	110 (149)	170 (230)	240 (325)
1-1/8	3/4 - 10 UNC	144 (195)	266 (360)	376 (509)
1-1/8	3/4 - 16 UNF	192 (260)	297 (402)	420 (569)
1-5/16	7/8 - 9 UNC	166 (225)	430 (583)	606 (821)
1-5/16	7/8 - 14 UNF	184 (249)	474 (642)	668 (905)
1-1/2	1 - 8 UNC	250 (339)	644 (873)	909 (1232)
1-1/2	1 - 12 UNF	274 (371)	705 (955)	995 (1348)
1-1/2	1 - 14 UNF	280 (379)	721 (977)	1019 (1381)
1-11/16	1-1/8 - 7 UNC	354 (480)	795 (1077)	1288(1745)
1-11/16	1-1/8 - 12 UNF	397 (538)	890 (1206)	1444 (1957)
1-7/8	1-1/4 - 7 UNC	500 (678)	1120 (1518)	1817 (2462)
1-7/8	1-1/4 - 12 UNF	553 (749)	1241 (1682)	2013 (2728)
2-1/16	1-3/8 - 6 UNC	655 (887)	1470 (1992)	2382 (3228)
2-1/16	1-3/8 - 12 UNF	746 (1011)	1672 (2266)	2712 (3675)
2-1/4	1-1/2 - 6 UNC	870 (1179)	1950 (2642)	3161 (4283)
2-1/4	1-1/2 - 12 UNF	979 (1327)	2194 (2973)	3557 (4820)

METRIC

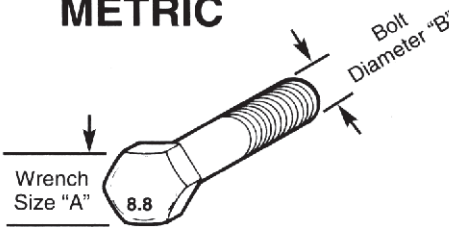

Numbers appearing on bolt heads indicate ASTM class.

Recommended torque in foot pounds (newton Meters).*

WRENCH SIZE (mm) "A"	BOLT DIA. (mm) "B"	ASTM 4.6	ASTM 8.8	ASTM 9.8	ASTM 10.9
8	5	1.8 (2.4)		5.1 (6.9)	6.5 (8.8)
10	6	3 (4)		8.7 (12)	11.1 (15)
13	8	7.3 (10)		21.1 (29)	27 (37)
16	10	14.5 (20)		42 (57)	53 (72)
18	12	25 (34)	74 (100)	73 (99)	93 (126)
21	14	40 (54)	118 (160)	116 (157)	148 (201)
24	16	62 (84)	167 (226)	181 (245)	230 (312)
30	20	122 (165)	325 (440)		449 (608)
33	22		443 (600)		611 (828)
36	24	211 (286)	563 (763)		778 (1054)
41	27		821 (1112)		1138 (1542)
46	30	418 (566)	1119 (1516)		1547 (2096)

*Use 75% of the specified torque value for plated fasteners. Use 85% of the specified torque values for lubricated fasteners.

Notes



**10 WALDEN DRIVE
ARDEN, NORTH CAROLINA 28704
(800) 438-5823 OR (828) 684-1234 FAX: (828) 684-0858
EMAIL: peco@lawnvac.com
WEBSITE: www.lawnvac.com**