



ADD-ON PTO POWER SYSTEM

DESIGNED FOR THE
BIG DOG R SERIES
R SERIES (DIABLO)

MODEL# 52020901

MODEL# 52120901



OPERATOR'S MANUAL

ASSEMBLY • OPERATION • MAINTENANCE

RESIDENTIAL BAGGING SYSTEM

TABLE OF CONTENTS

SECTION	PAGE	SECTION	PAGE
Safety	2	III OPERATING INSTRUCTIONS	11
Safety Alert Symbols	3	3-1 General Safety	11
Warranty	4	3-2 Operation & Tips On Mowing	11
I INTRODUCTION AND DESCRIPTION	5	3-3 Disengagement Of The PTO Assembly	11
1-1 Introduction	5	3-4 Unloading The Collection System	11
1-2 Description	5	IV MAINTENANCE	11
II INSTALLATION FOR USE	5	4-1 Maintenance Checklist	11
2-1 Preparation Of Mower	5	4-2 Lubrication	12
2-2 PTO Mount Assembly Installation	6	V PARTS AND SERVICE	12
2-3 PTO Assembly Installation	6	5-1 Parts And Service Information	12
2-4 Belt Installation/Removal/Adjustment	6-7	Exploded Views And Parts List	13-18
2-5 Blower Cone Installation	7	Safety Decals	19
2-6 Impeller Blade Removal and Replacement	8	Torque Specifications	20
2-7 Upper Hose Installation	8		
2-8 Lower Hose Installation	8		
2-9 Impeller Blade Removal and Replacement			
3 Blade Instructions	10		

SAFETY

1. Read the operator's manual carefully and familiarize yourself with the proper use of your attachment. Do not allow anyone who is not acquainted with the Safety Instructions to use your attachment.
2. Know the controls and how to stop quickly. READ THE OPERATOR'S MANUAL!
3. Do not allow children to operate the mower. Do not allow adults to operate the mower or grass collection system without proper instruction.
4. Be especially watchful of children and pets darting into the area while operating.
5. Keep your eyes and mind on your unit while mowing or operating your attachment. Don't let others distract you.
6. Do not attempt to operate your unit or mower when not in the driver's seat.
7. Always stop unit when emptying the container.
8. Stop unit, shut off deck attachment, set parking brake, shut off mower engine and remove spark plug wire before removing clogs, removing or replacing hose, boot, blower cone, or performing any maintenance.
9. If a slope must be ascended, back up the slope; drive forward when descending.
10. It is recommended that the container be kept only half full when negotiating any slopes. Start mowing on slopes when the container is empty and never mow slopes greater than 15 degrees.
11. Inspect your lawn and remove any foreign objects before mowing. Never deliberately run the mower across any foreign object.
12. Wear ear protection if the noise level is offensive.
13. Wear eye protection to prevent debris from damaging your eyes.

SAFETY

WARNING! **NEVER** operate the mower unless the discharge guard and either the deflector assembly or the vacuum collector adapter are fastened securely in place.

WARNING! Do not work around the mower deck boot or the blower area until you are certain that the mower blades and the blower impeller have stopped rotating.

WARNING! To avoid serious injury, perform maintenance on the vacuum collector; **ONLY AFTER STOPPING THE MOWER'S ENGINE AND WAITING FOR ALL MOVING PARTS TO COME TO A COMPLETE STOP.** Set the parking brake. Always remove the ignition key before beginning maintenance.

WARNING! For your own personal safety, **ALWAYS** back up the face of slopes. **NEVER** attempt to mow excessively steep slopes, and use caution when turning on any slope.

Safety Alert Symbol



This Safety Alert Symbol means: **“ATTENTION! BECOME ALERT! YOUR SAFETY IS INVOLVED!”**

This symbol is used to call attention to safety precautions that should be followed by the operator to avoid accidents. When you see this symbol, carefully read the message that follows and heed its advice. Failure to comply with safety precautions could result in death or serious bodily injury.

Safety Signs

The signal words **DANGER**, **WARNING**, and **CAUTION** are used on the equipment safety signs. These words are intended to alert the viewer to the existence and the degree of hazard seriousness.



White letters on **RED**

This signal word indicates a potentially hazardous situation which, if not avoided, will result in death or serious injury.



Black letters on **ORANGE**

This signal word indicates a potentially hazardous situation which, if not avoided, could result in death or serious injury.

It may also be used to alert against unsafe practices.



Black letters on **YELLOW**

This signal word indicates a potentially hazardous situation exist which, if not avoided, will result in minor or moderate injury.

It may also be used to alert against unsafe practices.

PECO LIMITED WARRANTY FOR NEW PRODUCTS

A. WHAT IS UNDER WARRANTY?

PECO extends the following warranties to the original purchaser of each new PECO consumer product subject to the following limitations.

1. PRODUCT WARRANTY: Any part of any consumer product, which is defective in material or workmanship as delivered to the purchaser will be repaired or replaced, as PECO elects, without charge for parts or labor, if the defect appears within 12 months from the date of delivery of the product to the original purchaser.

ALL DEFECTIVE PARTS MUST BE RETURNED TO PECO FOR INSPECTION TO DETERMINE VALIDITY OF WARRANTY CLAIMS. Freight and mailing will be borne by the customer.

2. PARTS REPLACED DURING WARRANTY: Any new PECO part which is furnished in performance of this warranty and is defective in material or workmanship as delivered to the purchaser will be repaired or replaced, as PECO elects, without charge if the defect appears within 90 days from the date of installation of such part or before the expiration of the original warranty period, whichever is later.

B. SECURING WARRANTY ADJUSTMENTS.

Call PECO for Return Authorization. Damaged or broken parts other than engines or batteries, must be returned to New PECO, Inc. 100 Airport Road, Arden, NC 28704 before any warranty adjustment can be authorized. At the time of requesting warranty adjustment, the purchaser must present evidence of the date of delivery of the product. The purchaser shall pay any charge for the product to and from Arden, NC.

C. ITEMS NOT COVERED BY PECO WARRANTY.

Engines and batteries attached to PECO products are covered under a separate warranty by the respective manufacturer.

D. UNAPPROVED ALTERATION OR MODIFICATION.

All obligations of New PECO, Inc. under this warranty shall be terminated if products are altered or modified in ways not approved by New PECO, Inc.

E. ACCIDENTS AND NORMAL MAINTENANCE.

The warranty covers only defective material and workmanship. It does not cover depreciation or damage caused by normal wear, accident, improper use or abuse of products. The cost of normal maintenance and normal replacement of service items such as belts, cutting blades, hoses, etc., which are not defective shall be paid for by the purchaser.

F. NO REPRESENTATIONS ADDITIONAL WARRANTIES, DISCLAIMER.

Neither New PECO, Inc. nor any company affiliated with it makes any warranties, representations or promises as to the quality of performance of its products other than those set forth herein. Except as described above, New PECO, Inc. makes no other warranties **AND SPECIFICALLY DISCLAIMS ANY AND ALL IMPLIED WARRANTIES OF FITNESS AND MERCHANTABILITY.**

G. ANY MACHINE USED FOR RENTAL PURPOSES ARE GUARANTEED FOR 45 DAYS FROM DATE OF ORIGINAL SALE ONLY.

H. REMEDIED EXCLUSIVE.

The only remedies the purchaser has in connection with the breach or performance of any warranty on New PECO, Inc. consumer products are set forth above. In no event will PECO be liable for special incidental or consequential damages.

1. NO SERVICE CENTER WARRANTY.

The selling Service Center makes no warranty on his own on any item warranted by New PECO, Inc. unless he delivers to purchaser a separate written warranty certificate specifically warranting the item. The dealer has no authority to make any representation or promise on behalf of PECO or to modify the terms of this warranty in any way.

Section I

INTRODUCTION & DESCRIPTION

1-1 Introduction

This manual is provided to give you instructions on how to install the Peco PTO system in combination with your Excel Two Bag Catcher. This manual will provide operating instructions for the Peco PTO system only. **NOTE:** For all other instructions, you will refer to your Excel Two Bag Catcher owner's manual and your Big Dog owner's manual.

1-2 Description

The grass collection system is designed for turf maintenance where there is a need to collect the grass clippings as the mower cuts the turf. It is also used for picking up leaves in pre-season and post-season clean-up. The Peco blower, mounted on the right side of the unit, uses a belt and gearbox system from the engine PTO shaft. Drive train protection comes through belt slippage. The blower draws grass clippings from the discharge area of the cutting deck back to the (2) collection bags at the rear portion of the mower frame. The operator can engage the blower with a spring-lock engagement handle on the right side of the unit. Once the bags are full with clippings, they can be easily released for dumping.

Section II

INSTALLATION FOR USE

2-1 Preparation Of Mower

Remove the drive belt from the engine drive pulley. From the underside of the engine, disconnect the wiring harness attached to the electric clutch. Remove the bolt and electric clutch from the mower. Remove the D-drive spacer using an arbor press or equivalent. On removal, adjacent bearing OUTER race must be supported or bearing damage may occur. Refer to Figure 2-1a.

Figure 2-1c

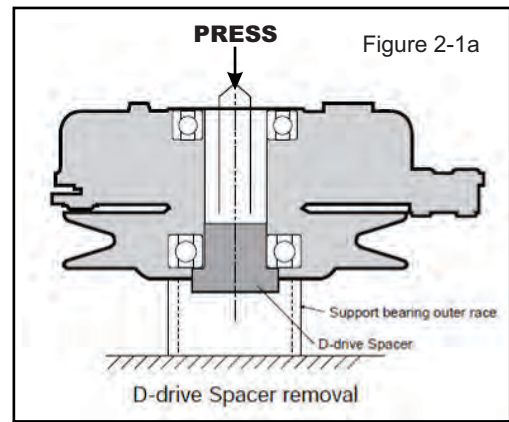
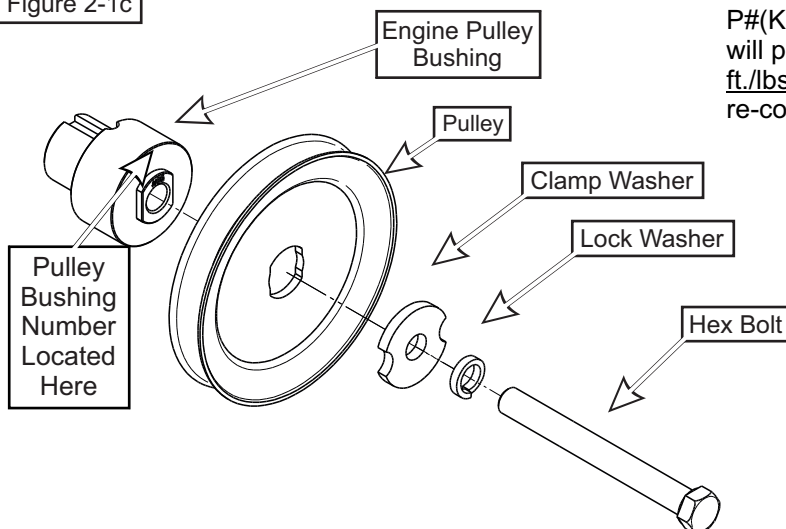

The engine pulley assembly must be installed using an arbor press or equivalent. Upon installation, opposite bearing inner race must be supported or bearing damage may occur. Refer to Figure 2-1c.

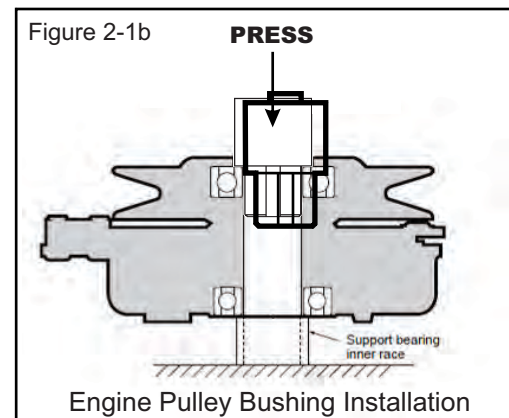

Once the Engine Pulley Bushing is installed, reattach the clutch assembly to the mower and then review Figure 2-1c.

For Kohler Engines: Use engine pulley bushing stamped with the #12 on the bushing, P#(S0197).
For Kawasaki Engines: Use engine pulley bushing stamped with the #1 on the bushing, P#(S0172). Fasten the engine pulley to the electric clutch assembly using (1) Clamp Washer P#(K0278), (1) 7/16" hi-collar lock washer P#(K0140) and (1) 7/16"-20 x 4-1/2" HHCS P#(K0427) as shown in Figure 2-1d. The added pulley will power the collection system. Torque the bolt to 55 ft./lbs. Re-connect the wiring harness to the clutch and re-connect the drive belt.

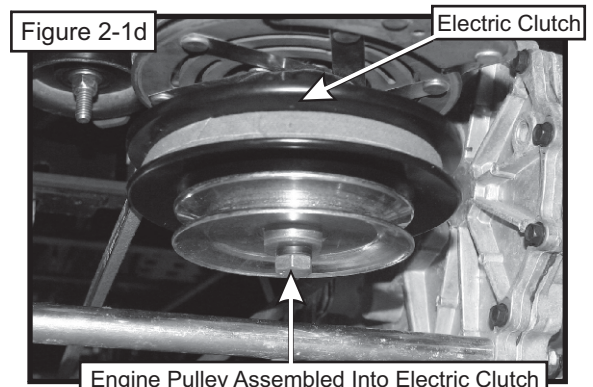

2-2 PTO Mount Plate Assembly Installation

With the lid assembly removed, disconnect the frame mounting tube and bumper from the bumper tie. Position the PTO mount plate assembly P#(A1816) as shown in Figure 2-2a. Use the existing hardware from the bumper tie to secure the PTO mount plate assembly to the bumper tie. Leave the hardware loose until the frame mounting tube is re-attached.

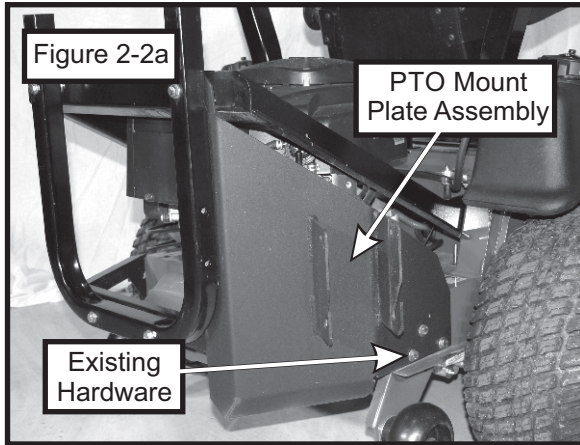

Secure the frame mounting tube to the frame support tie using the existing hardware from the frame tube. You will add (1) washer P#(K1446) between the frame tube and support tie and (2) washers between the frame tube and bumper tie. Tighten all the hardware at this time. Refer to Figure 2-2b and 2-2c.

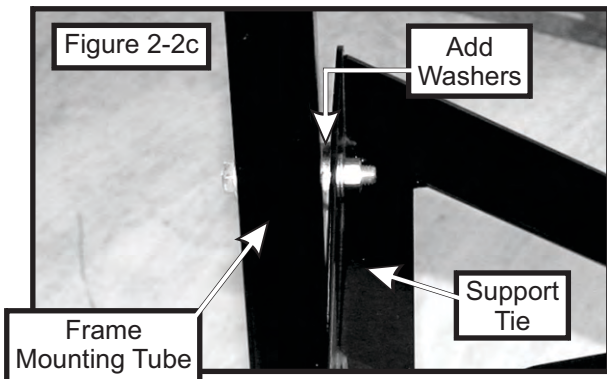
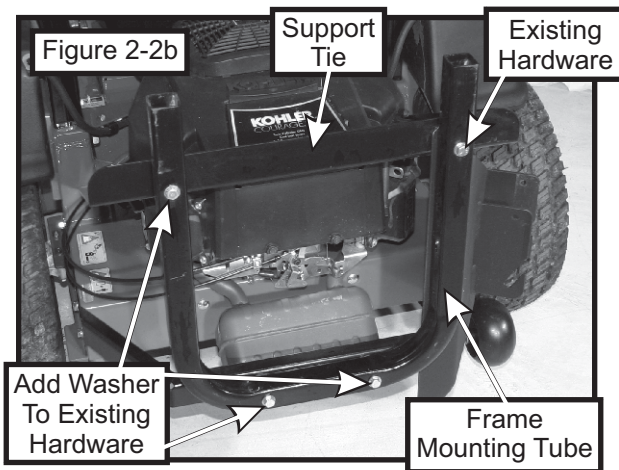

2-3 PTO Assembly Installation

Insert the PTO assembly P#(A1815) into the slots on the PTO mount plate assembly as shown in Figure 2-3a.

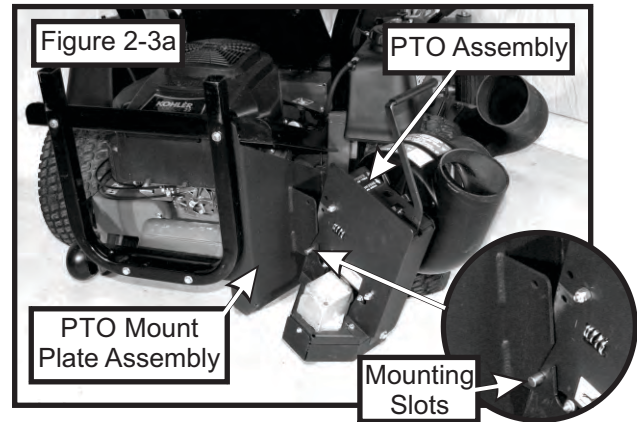

Remove the gear box pulley guard P#(B0478) and (3) 1/4"-20 x 1/2" HHSTS P#(K0353) from the PTO assembly in preparation for the belt installation. Refer to Figure 2-3b.

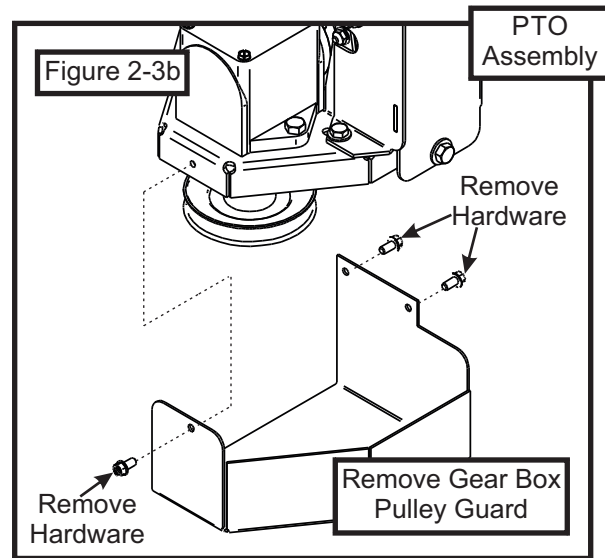

2-4 Belt Installation/Removal and Adjustment

Installation/Removal: With the PTO mount pin P#(B0274) removed, loosen the (4) 5/16"-18 x 3/4" HHCS P#(K1153) that secure the gear box to the PTO assembly. Loosen the adjustment bolt (1) 3/8"-16 x 2" hex bolt P#(K0348). Slide the gearbox towards the mower until there is enough clearance for the kevlar belt to slide over both the engine and gearbox pulleys. Install the A54K kevlar belt P#(M0255). Insert the PTO mount pin P#(B0274), and secure the pin with (1) hair pin clip P#(K0086). Refer to Figures 2-4a through 2-4e.

Figure 2-4a

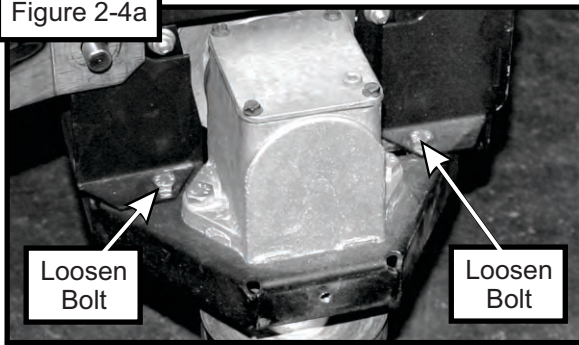

Figure 2-4b

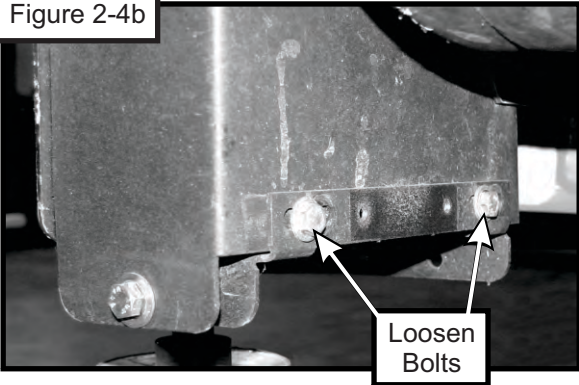
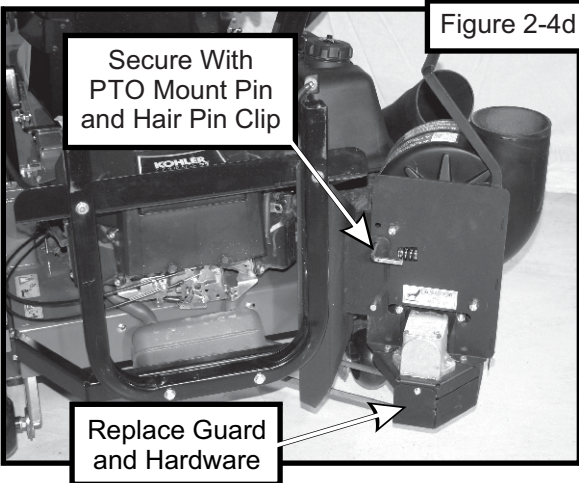
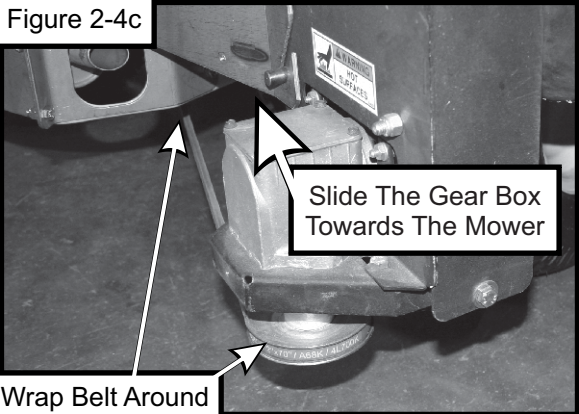
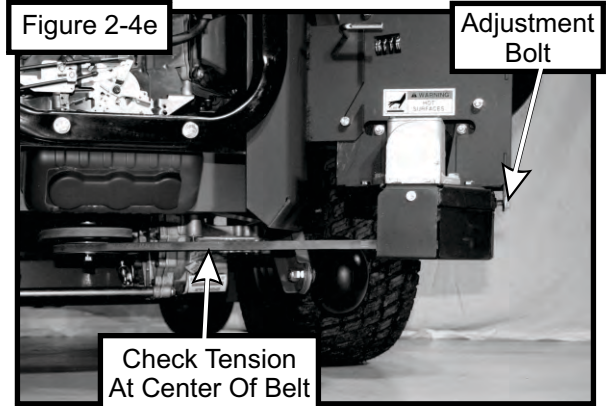

Figure 2-4c



Adjustment: To adjust the belt tension, turn the adjustment bolt clockwise until there is 1" of deflection, with 10-11lbs of pressure applied to the center of the belt. When the belt has the proper tension, tighten the (4) 5/16"-18 x 3/4" HHCS that secure the gear box to the PTO assembly. Replace the belt guard and (3) 1/4"-20 x 1/2" HHSTS. Refer to Figure 2-4e.



2-10 Blower Cone

Installation/Removal

Fasten the blower cone P#(V0016) to the blower housing located on the PTO assembly. Use (3) 1/4"-20 x 3/4" HHCS P#(K1222), (3) 1/4" lock washers P#(K0039), and (3) 1/4" flat washers P#(K0037) to secure the blower cone to the blower housing. Refer to Figure 2-10 for reference.

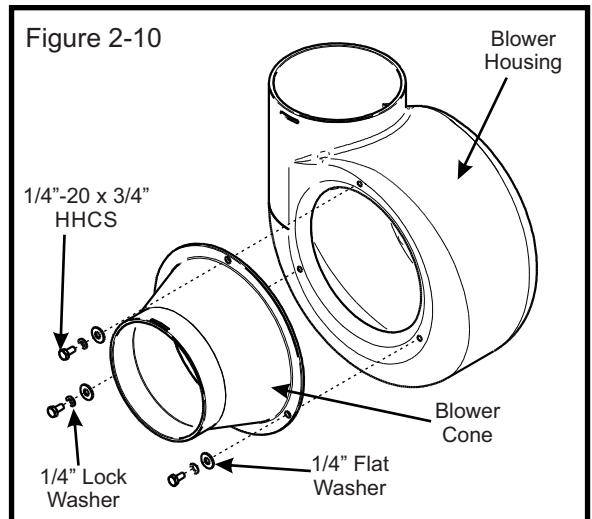

2-6 Impeller Blade Removal/Replacement



BEFORE REMOVING/REPLACING THE IMPELLER BLADES, BE SURE THE MOWER IS TURNED OFF, THE PTO ASSEMBLY IS DISENGAGED AND THE NEGATIVE CABLE IS REMOVED FROM THE BATTERY. FAILURE TO DO SO MAY RESULT IN SEVERE INJURY OR DEATH.

Remove the blower cone P#(V0016) from the blower housing located on the PTO assembly P#(A1132). With the blower cone removed, you will have access to the impeller blades P#(E7003A). Refer to Figure 2-6a.

Remove the (2) 3/8"-16 x 1-1/4" HHCS P#(K1192), (2) 3/8" I.T. lock washer P#(K0049), and (2) 3/8"-16 flange nut P#(K1215) that secure the (2) impeller blades P#(E7003) to the PTO shaft P#(B0460). Inspect impeller blades and replace if necessary. When replacing the impeller blades, run the impeller blades to the shoulder of the PTO shaft before tightening hardware. Refer to Figure 2-6b for reference.

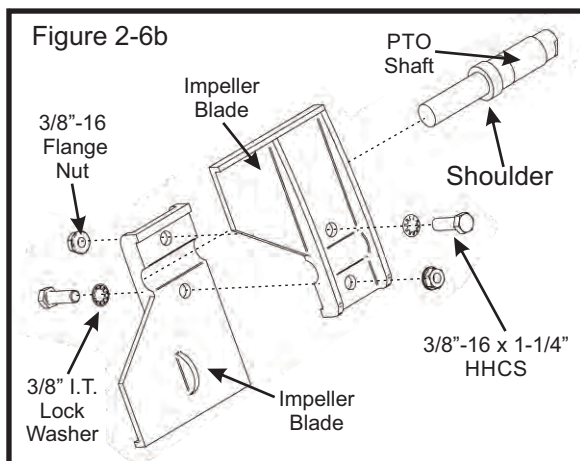
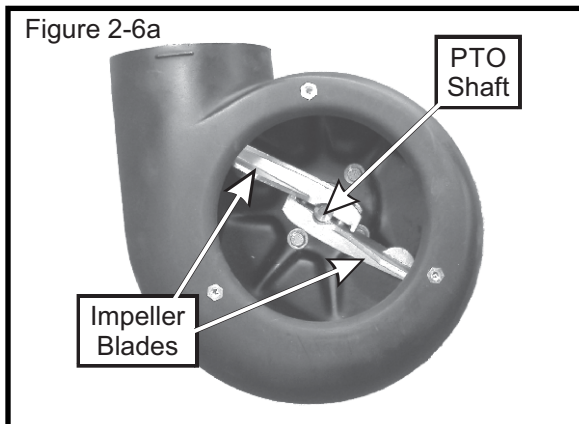

2-7 Upper Hose Installation

Attach the lid assembly to the frame mounting tube. Slide one end of the 6" x 13" hose onto the blower housing. Slide the other end of the hose onto the inlet tube on the lid assembly. Secure the hose to the blower housing using (1) hose clamp P#(J0060). Secure the hose to the inlet tube using the existing clamp. Refer to Figure 2-7.

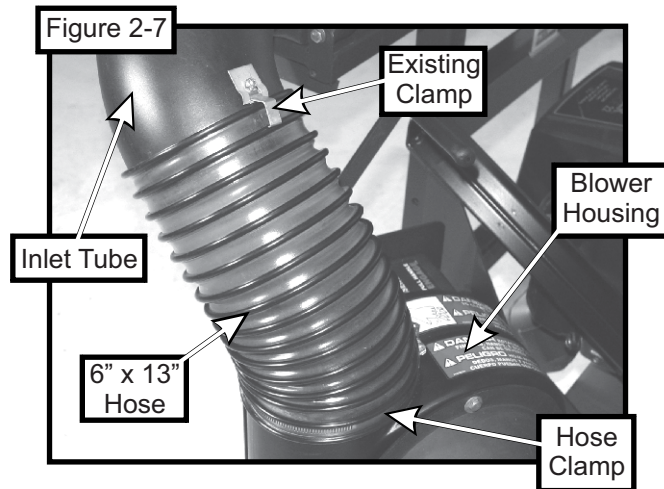

2-8 Lower Hose Installation

Slide one end of the 6" x 19" onto the existing deck chute. Slide the other end of the 6" x 19" hose onto the blower cone P#(V0016) on the PTO assembly. Secure the lower hose using (2) hose clamps P#(J0060). Refer to Figure 2-8a for reference.

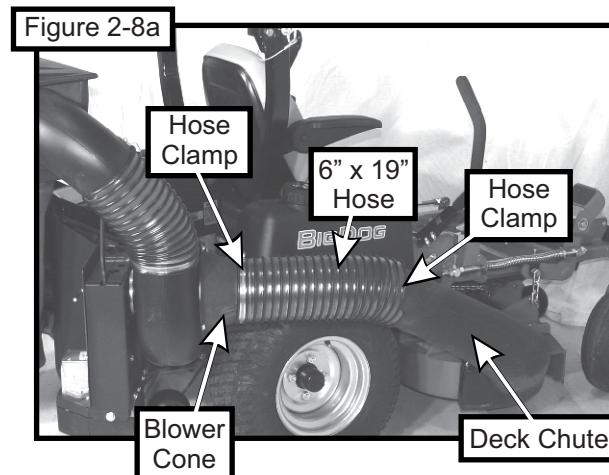
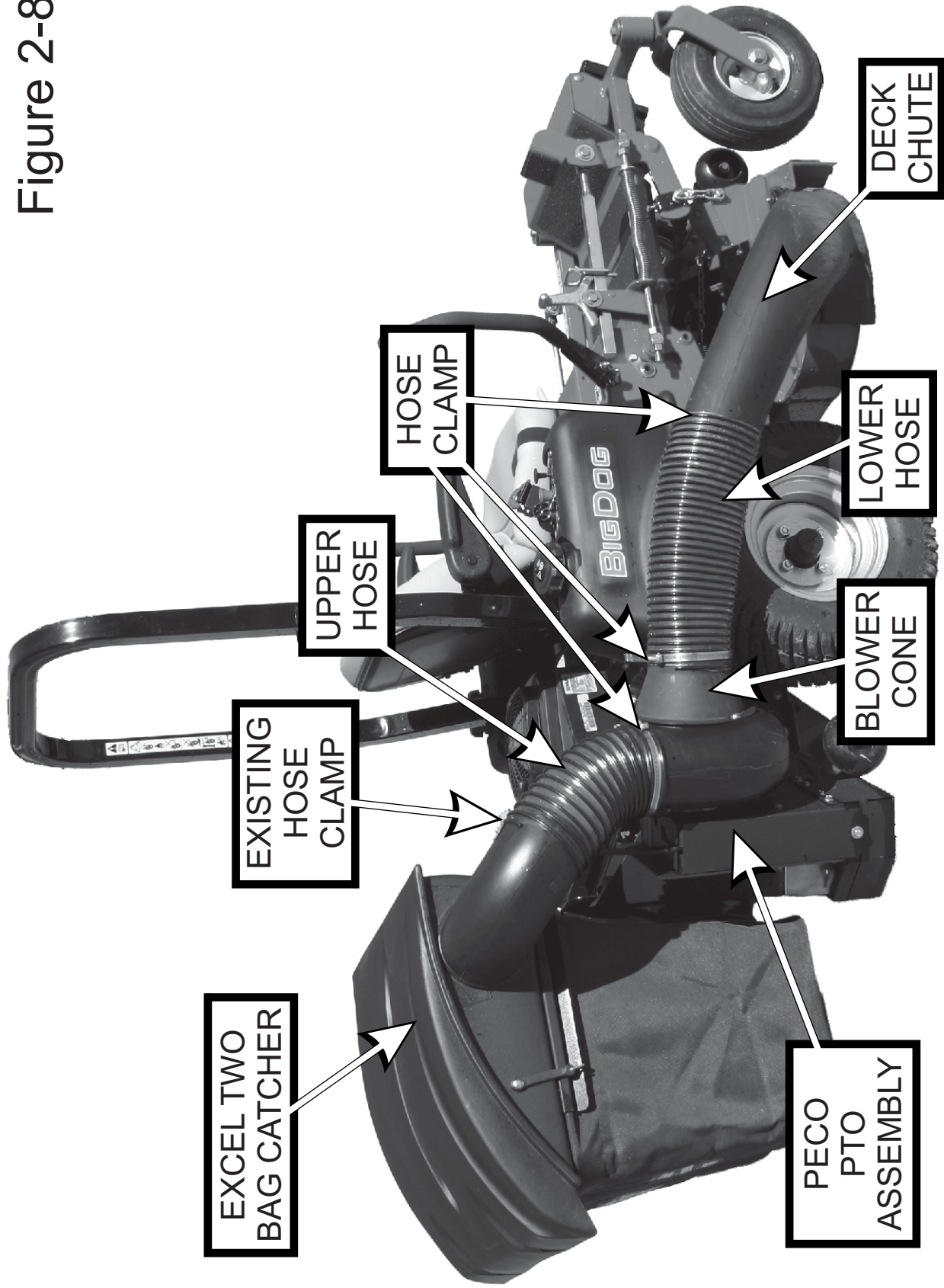

Figure 2-8b shows the complete PTO collection system assembly with all hoses and clamps.

Figure 2-8b



2-9 Impeller Blade Removal/Replacement (3-Blade)

To Remove: To access the impeller blade, remove the blower cone P#(V0016) and blower cone hardware from the blower housing. Remove the 5/16"-24 x 7/8" left hand thread hex bolt P#(K1171) and washer P#(K1446). Insert (1) 1/2"-13 x 1" hex bolt into the threads on the impeller blade. Tighten the hex bolt until the impeller blade breaks free from the PTO shaft. Remove the impeller blade assembly P#(A1839) from the PTO shaft. Remove the key P#(J0254) from the PTO shaft.

To Replace: Insert the key P#(J0254) into the keyway slot on the PTO shaft. Align the keyway slot on the bushing of the impeller blade assembly with the key on the PTO shaft and insert the impeller blade onto the PTO shaft. Secure the impeller blade with (1) 5/16"-24 x 7/8" left hand thread hex bolt P#(K1171) and (1) washer P#(K1446). Replace the blower cone P#(V0016) and blower cone hardware. Refer to Figure 2-9 for reference.

Figure 2-9

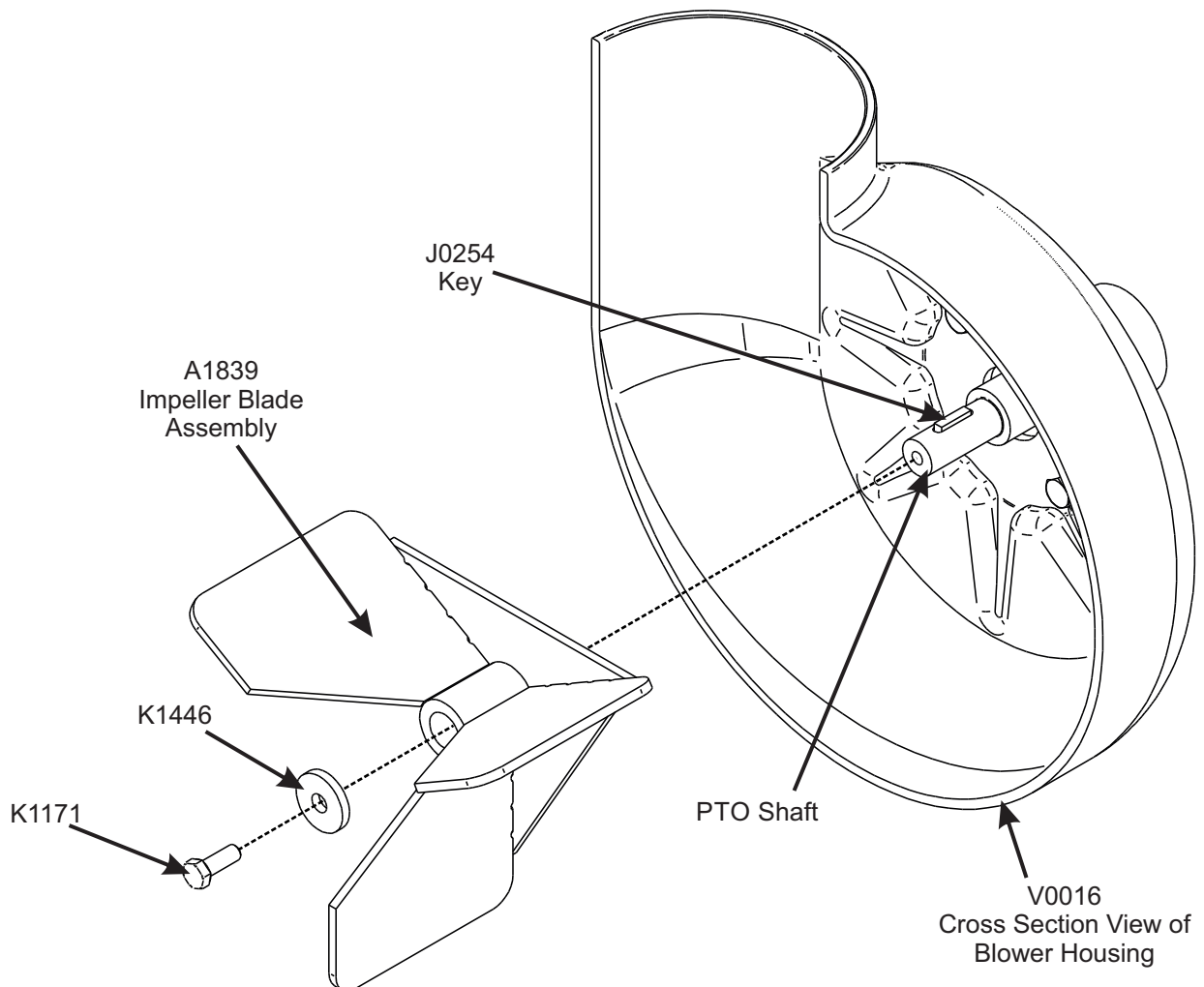

SECTION III OPERATING INSTRUCTIONS

3-1 General Safety

Only qualified people familiar with this operator's manual and the mower's operator's manual should operate this machine.

3-2 Operation And Tips On Mowing

- A. Perform BEFORE EACH USE the maintenance list in paragraph 4-1.
- B. Start mower.
- C. With the mower at high idle speed, engage the mower deck.
- D. While seated in the operator's seat, pull the engagement handle of the PTO assembly towards the operator's seat until the handle slides into position in the retaining slot. With the PTO assembly engaged, you can proceed to operate the control levers of the mower.

NOTE: If the collection system does not appear to be collecting the grass clippings, disengage the deck and PTO assembly (Section 3-3), then, engage the parking brake and turn the mower off. Check upper and lower hoses for any clogs.

To obtain the maximum effectiveness from your collection system, the tips listed below should be followed:

- * Watch your speed- Normal conditions will allow a speed of up to approximately 4 mph, but thick, heavy damp conditions will require reduced ground speed.
- * Mow with sharp blades- A sharp blade cuts cleaner.
- * Wet grass and leaves will decrease effectiveness and will increase horsepower requirements.
- * Mow at higher cutting heights- Remove and mulch no more than 2" of grass length with each mowing. (Experts recommend not cutting off more than 1/3 of the grass blade length at any given time.)
- * Mow twice, at different height settings, (high, then low), if grass is extra tall.
- * Remember that horsepower requirements will vary with the mowing conditions such as type and height of turf grass, moisture content, amount of leaves, whether the terrain is flat or hilly, etc.

3-3 Disengagement Of The PTO Assembly

A. To disengage the PTO assembly, slide the engagement handle out of the retaining slot and push the engagement handle away from the operator's seat.

WARNING: The PTO assembly blades will continue to spin. DO NOT TOUCH the PTO assembly, pulleys, or the belt until the tractor is turned off. DO NOT adjust the belt tension until the mower is turned off. Refer to section 2-4 of the manual.

3-4 Unloading The Collection System

NOTE: To determine when the collection bags are full, follow the following steps:

- A. Stop the forward movement of the mower.
- B. Disengage the mower deck.
- C. Disengage the PTO assembly.
- D. Engage the parking brake.
- E. Once the parking brake has been engaged, then and only then, walk behind the mower and check the collection bags by first unhooking the rubber strap with S-hook that secures the plastic top, then lift the plastic hood. Load in bags should not exceed the height of the installed bag.
- F. To remove the bags from the frame slide bags out and turn bags over to deposit clippings.
- G. Slide empty bags back onto the frame and secure plastic top with the rubber strap with S-hook.

NOTE: Do not allow collection bags to become over-filled as potential damage may occur to your equipment. Also, be sure to clean the hood screen as needed.

SECTION IV MAINTENANCE

4-1 Maintenance Checklist

Before each use:

1. Check blades and spindles to be sure that no foreign objects, such as wire or steel strapping bands, are wrapped around them.
2. Inspect blades for wear. Replace if necessary. If it is necessary to sharpen the blades, remove the blades from the spindles before sharpening. DO NOT sharpen blades while still attached to the mower.

3. Make sure all shields are in place and in good condition. Repair or replace any missing or damaged shields.
4. Perform lubrication per paragraph 4-2.
5. Listen for abnormal sounds, which might indicate loose parts, damaged bearings, or other damage. Correct any deficiency before continuing operation.
6. With the engine off, engage the blower assembly. Check the belt tension and inspect the pulley belt for cracks or tears.
7. Check for wear or deterioration of the upper or lower hoses. If there are any portions of the hose that have been torn or worn through, replace immediately.

After Each Use:

1. Clean all debris from machine especially from the container, underneath the belt shields, and safety decals. Replace any missing or illegible decals.
2. Inspect the unit for worn or damaged components. Repair or replace before the next use. Any replacement component installed during repair shall include the component's current safety decal specified by the manufacturers to be affixed to the component.
3. Check belt for proper tension.

4-2 Lubrication

NOTE: Use only white lithium based grease for lubrication of the shaft on the blower assembly.

1. On initial use: Grease the fitting on the blower shaft.
2. Every 25 hours of use: Re-grease the grease fitting.
3. Every 200 hours of use: Check oil levels in gear box. Oil in gear box should cover the gears. If not, fill using an EP90 weight oil. 6oz. will fill the gear box from empty.

SECTION V PARTS AND SERVICE

5-1 Parts And Service Information

Collection system owners should record the name and telephone number of their Service Center. Your Service Center will be happy to supply replacement parts, accessories, and do any service or repairs to your collection system. If for any reason your Service Center is unable to service your collection system or supply replacement parts, contact PECO Inc. and include the following information on the chart below.

THE SERIAL NUMBER PLATE
IS LOCATED ON THE PTO
ASSEMBLY P#(A1815)

WRITE THE MODEL AND
SERIAL NUMBER IN THE
BOX TO THE LEFT
FOR FUTURE REFERENCE.

Unit Model Number: _____
Unit Engine Size: _____
Unit Serial Number: _____
Date of purchase: ____/____/____
Dealer/Distributor Name: _____
Address: _____ **State:** _____ **Zip:** _____
Phone Number: _____

MODEL#: 52020901

MOWER NAME: BIG DOG

MOWER MODEL: R-748 & R-754 DIABLO

MOWER DECK SIZE: 48" & 54" DECK

DESIGNED FOR: EXCEL TWO BAG CATCHER

PTO DRIVEN

MANUAL #Q0426

A1823 UNIT ASSEMBLY



FOR YEAR: 2011-2012

REVISED: 2/11/2013

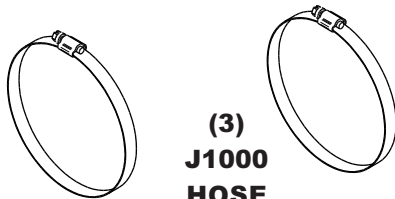

(3)
J1000
HOSE
CLAMPS



(1)
F0001
6" x 13"
UPPER HOSE

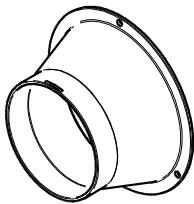

(1)
V0016
BLOWER
CONE 6"

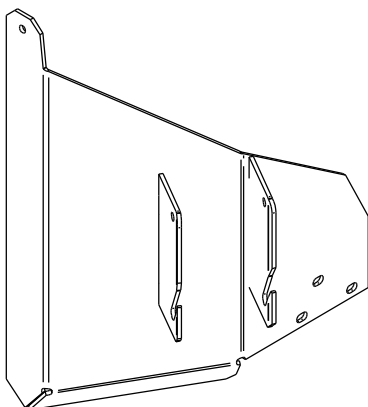

(1)
A1816
PTO MOUNT
PLATE
ASSEMBLY



(1)
M0255
A54K KEVLAR
BELT

(1)
HB0464
ENGINE
PULLEY
HARDWARE
BAG



(1)
F0001
6" x 19"
LOWER HOSE



(1)
HB0463
UNIT
HARDWARE
BAG

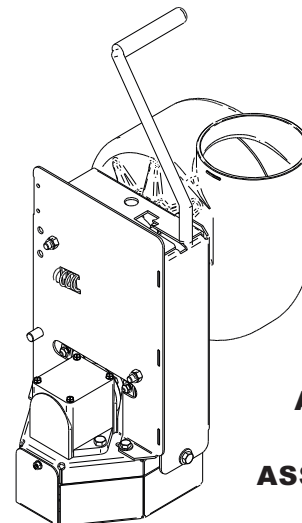

(1)
A1815
PTO
ASSEMBLY

MODEL#: 52120901 P2B+

MOWER NAME: BIG DOG

MOWER MODEL: R-748 & R-754 DIABLO

MOWER DECK SIZE: 48" & 54" DECK

DESIGNED FOR: EXCEL TWO BAG CATCHER

PTO DRIVEN

MANUAL #Q0426

A1908 UNIT ASSEMBLY



FOR YEAR: 2011-2013

REVISED: 2/11/2013



(3)
J0060
6" HOSE
CLAMPS

(1)
F0001
6" x 13"
UPPER HOSE



(1)
F0001
6" x 19"
LOWER HOSE



(1)
V0016
BLOWER
CONE 6"



(1)
M0255
A54K KEVLAR
BELT



(1)
HB0464
ENGINE
PULLEY
HARDWARE
BAG



(1)
HB0463
UNIT
HARDWARE
BAG

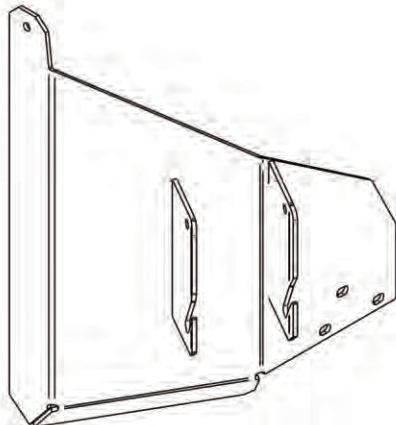

(1)
A1816
PTO MOUNT
PLATE
ASSEMBLY

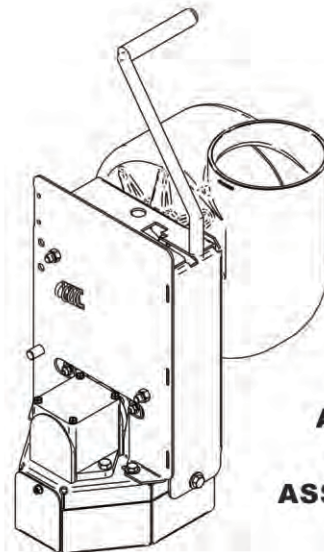

(1)
A1841
PTO
ASSEMBLY

A1815 PTO ASSEMBLY EXPLODED PARTS VIEW

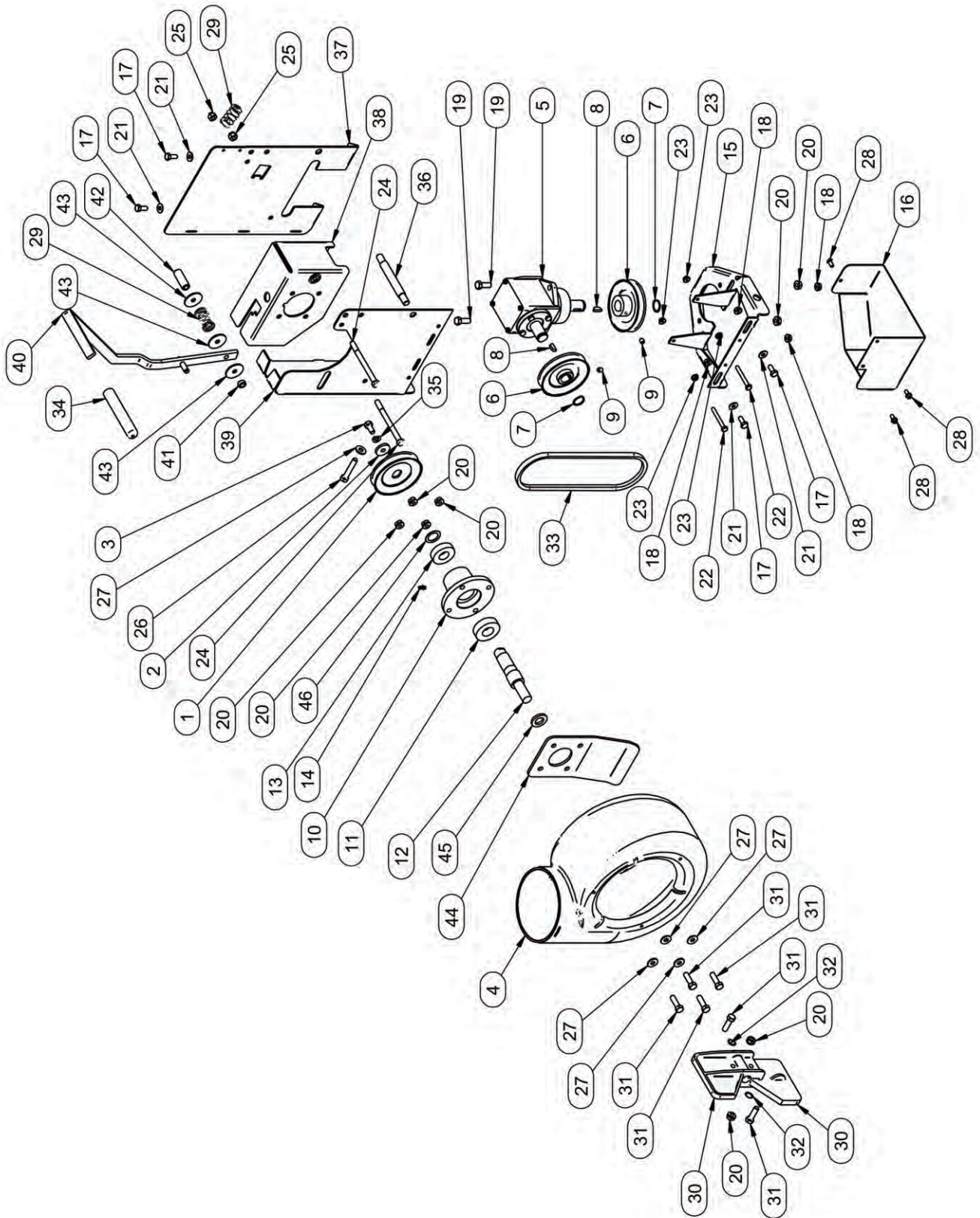

A1815 PTO ASSEMBLY**EXPLODED PARTS VIEW DESCRIPTION**

Item #	Doc #	Title	Qty
1	M0266	'A' PULLEY FOR DECK DRIVE PTO	1
2	K1446	1.187 OD x .380 ID x .187 WASHER	1
3	k1190	3/8"-16 x 3/4" HHCS	1
4	V0015	BLOWER HSG.	1
5	A0431	GEAR BOX	1
6	A0498	PULLEY ASSY. FOR GEAR BOX	2
7	K0360	7/8" SNAP RING	2
8	J0272	#9 WOODRUFF KEY	2
9	K0035	5/16-18 SET SCREW	2
10	E0015	PTO SHAFT HOUSING	1
11	n0147	BEARING 2.0472 OD, 0.9843 ID, 0.5906 W (6205RS PEER)	1
12	B0460	PTO SHAFT	1
13	N0165	BEARING	1
14	J0801	1/4"-28 ZIRC FITTING	1
15	A1003	BASE PLATE ASSY.	1
16	B0478	GEAR BOX PULLEY GUARD	1
17	K1153	5/16"-18 x 3/4" HHCS	4
18	K1178	5/16"-18 FLANGE NUT	4
19	k1191	3/8"-16 x 1" HHCS	2
20	K1215	3/8"-16 FLANGE NUT	8
21	K0037	1/4" FLAT WASHER .75 OD x .314 ID x .060 T	4
22	k1150	1/4"-20 x 2-1/4" HHCS	2
23	K1126	1/4"-20 FLANGE NUT	4
24	K1202	3/8"-16 x 4-1/2" HHCS G5	2
25	k1216	3/8"-16 NYLOC NUT	2
26	K0348	3/8"-16 x 2" ALL THREAD HHCS	1
27	k0042	5/16" FLAT WASHER .875 OD x .380 ID x .075 T	5
28	K0353	1/4"-20 x 1/2" HHSTS	3
29	J0303	SPRING	2
30	E7003	IMPELLER BLADE	2
31	K1192	3/8"-16 x 1-1/4" HHCS	6
32	K0049	3/8" INTERNAL LOCK WASHER	2
33	M0267	A28K KEVLAR BELT	1
34	V1151	5/8" ID x 4-3/4" BLACK HANDLE GRIP	1
35	K0048	3/8" LOCK WASHER	1
36	B0505	PTO ARM MNT. ROD	1
37	B0506	LT. PTO ARM	1
38	B0642	BLWR. MNT. BRKT.	1
39	B0643	RT PTO ARM	1
40	A1138	PTO HANDLE ASSY	1
41	B0510	SPACER BUSHING	1
42	B0511	SPACER BUSHING	1
43	K0403	WASHER 1-1/2" OD x 3/8" ID	3
44	B0739	Blower Hsg. Stiffener Pl.	1
45	S0002	Blade Shaft Spacer	1
46	K0070	Flat Washer SS	1

A1841 3-BLADE PTO ASSEMBLY EXPLODED PARTS VIEW

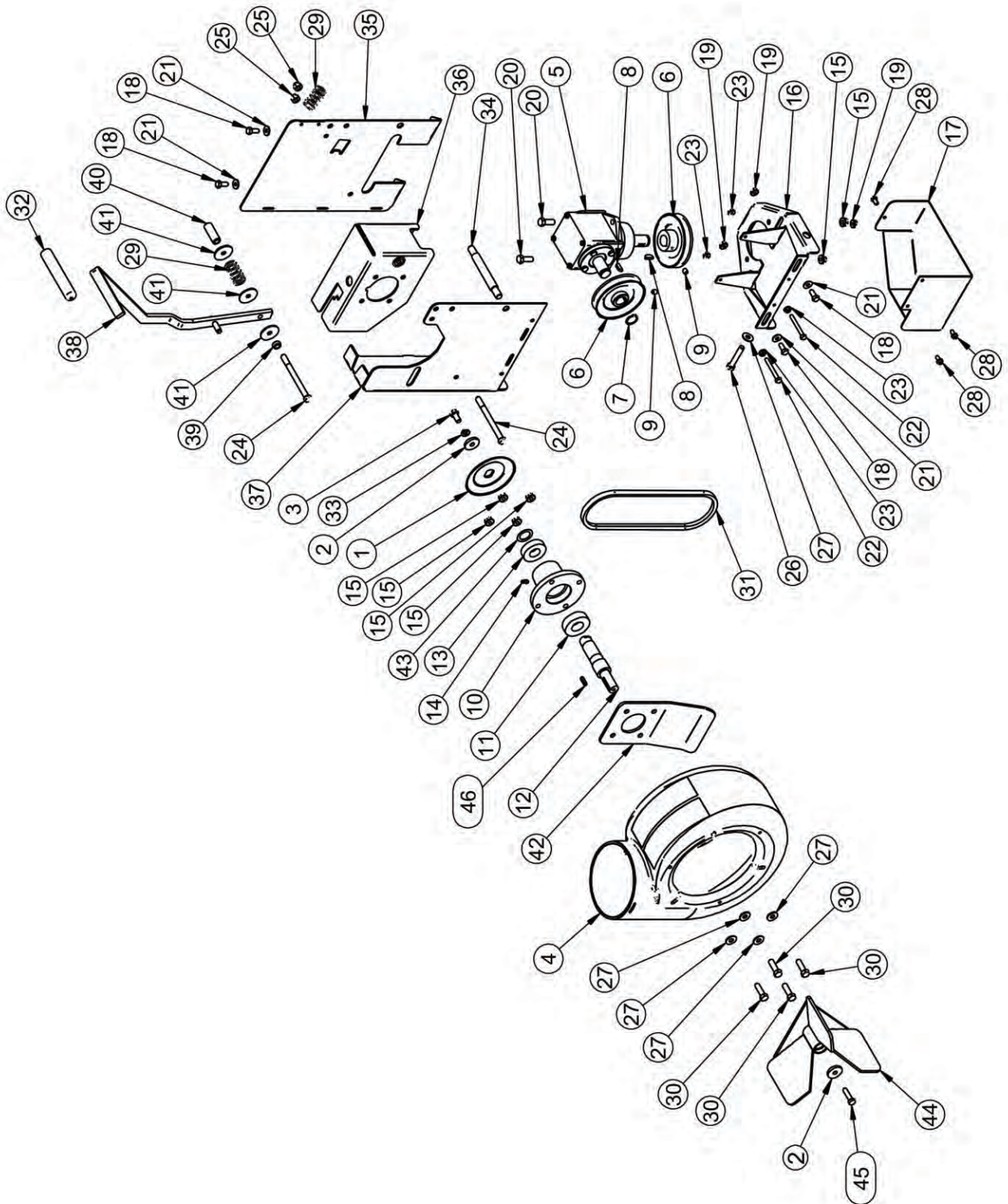

**A1841 3-BLADE PTO ASSEMBLY
EXPLODED PARTS VIEW DESCRIPTION**

Item #	Doc #	Title	Qty
1	M0266	'A' PULLEY FOR DECK DRIVE PTO	1
2	K1446	1.187 OD x .380 ID x .187 WASHER	2
3	k1190	3/8"-16 x 3/4" HHCS	1
4	V0015	BLOWER HSG.	1
5	A0431	GEAR BOX	1
6	A0498	PULLEY ASSY. FOR GEAR BOX	2
7	K0360	7/8" SNAP RING	2
8	J0272	#9 WOODRUFF KEY	2
9	K0035	5/16-18 SET SCREW	2
10	E0015	PTO SHAFT HOUSING	1
11	n0147	BEARING 2.0472 OD, 0.9843 ID, 0.5906 W (6205RS PEER)	1
12	B0460	PTO SHAFT	1
13	N0165	Bearing	1
14	J0801	1/4"-28 Zirc Fitting	1
15	K1215	3/8"-16 FLANGE NUT	7
16	B0466	BASE PL.	1
17	B0478	GEAR BOX PULLEY GUARD	1
18	K1153	5/16"-18 x 3/4" HHCS	4
19	K1178	5/16"-18 FLANGE NUT	4
20	k1191	3/8"-16 x 1" HHCS	2
21	K0037	1/4" Flat Washer .75 OD x .314 ID x .060 T	4
22	k1150	1/4"-20 x 2-1/4" HHCS	2
23	K1126	1/4"-20 FLANGE NUT	4
24	K1202	3/8"-16 x 4-1/2" HHCS G5	2
25	k1216	3/8"-16 NYLOC NUT	2
26	K0348	3/8"-16 x 2" ALL THREAD HHCS	1
27	k0042	5/16" FLAT WASHER .875 OD x .380 ID x .075 T	5
28	K0353	1/4"-20 x 1/2" HHSTS	3
29	J0303	SPRING	2
30	K1192	3/8"-16 x 1-1/4" HHCS	4
31	M0267	A28K KEVLAR BELT	1
32	V1151	5/8" ID x 4-3/4" BLACK HANDLE GRIP	1
33	K0048	3/8" LOCK WASHER	1
34	B0505	PTO ARM MNT. ROD	1
35	B0506	LT. PTO ARM	1
36	B0642	BLWR. MNT. BRKT.	1
37	B0643	RT PTO ARM	1
38	A1138	PTO HANDLE ASSY	1
39	B0510	SPACER BUSHING	1
40	B0511	SPACER BUSHING	1
41	K0403	WASHER 1-1/2" OD x 3/8" ID	3
42	B0739	Blower Hsg. Stiffener Pl.	1
43	K0070	Flat Washer SS	1
44	A1839	3-Blade Impeller Assy.	1
45	K1171	5/16"-24 LH x 1-1/4" HHCS GR. 5 w/ Patch Coating	1
46	J0254	3/16" x 3/16" x 3/4" Key	1

SAFETY DECALS

To promote safe operation, PECO Inc. supplies safety decals on all products manufactured. Damage can occur to safety decals either through shipment, use or reconditioning. Contact your local Service Center for replacement decals.



Part #: R2008
Rotating Blades Label



Part #: R2007
Never Use Hands Label



Part #: R4037
Warning: Hot Surface Label



Part #: R1100
Engage-Disengage Label

TORQUE SPECIFICATIONS

AMERICAN Bolt Head Markings

Recommended Torque in Foot Pounds (Newton Meters).*

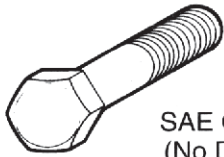

SAE Grade 2
(No Dashes)

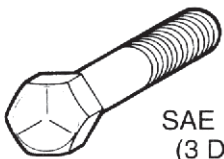

SAE Grade 5
(3 Dashes)

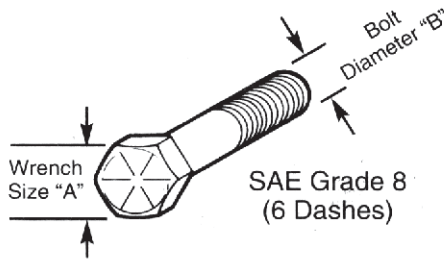

SAE Grade 8
(6 Dashes)

WRENCH SIZE (IN.) "A"	BOLT DIAMETER (IN.) "B" AND THREAD SIZE	SAE GRADE 2	SAE GRADE 5	SAE GRADE 8
7/16	1/4 - 20 UNC	6 (7)	8 (11)	12 (16)
7/16	1/4 - 28 UNF	6 (8)	10 (13)	14 (18)
1/2	5/16 - 18 UNC	11 (15)	17 (23)	25 (33)
1/2	5/16 - 24 UNF	13 (17)	19 (26)	27 (37)
9/16	3/8 - 16 UNC	20 (27)	31 (42)	44 (60)
9/16	3/8 - 24 UNF	23 (31)	35 (47)	49 (66)
5/8	7/16 - 14 UNC	32 (43)	49 (66)	70 (95)
5/8	7/16 - 20 UNF	36 (49)	55 (75)	78 (106)
3/4	1/2 - 13 UNC	49 (66)	76 (103)	106 (144)
3/4	1/2 - 20 UNF	55 (75)	85 (115)	120 (163)
7/8	9/16 - 12 UNC	70 (95)	109 (148)	153 (207)
7/8	9/16 - 18 UNF	79 (107)	122 (165)	172 (233)
15/16	5/8 - 11 UNC	97 (131)	150 (203)	212 (287)
15/16	5/8 - 18 UNF	110 (149)	170 (230)	240 (325)
1-1/8	3/4 - 10 UNC	144 (195)	266 (360)	376 (509)
1-1/8	3/4 - 16 UNF	192 (260)	297 (402)	420 (569)
1-5/16	7/8 - 9 UNC	166 (225)	430 (583)	606 (821)
1-5/16	7/8 - 14 UNF	184 (249)	474 (642)	668 (905)
1-1/2	1 - 8 UNC	250 (339)	644 (873)	909 (1232)
1-1/2	1 - 12 UNF	274 (371)	705 (955)	995 (1348)
1-1/2	1 - 14 UNF	280 (379)	721 (977)	1019 (1381)
1-11/16	1-1/8 - 7 UNC	354 (480)	795 (1077)	1288(1745)
1-11/16	1-1/8 - 12 UNF	397 (538)	890 (1206)	1444 (1957)
1-7/8	1-1/4 - 7 UNC	500 (678)	1120 (1518)	1817 (2462)
1-7/8	1-1/4 - 12 UNF	553 (749)	1241 (1682)	2013 (2728)
2-1/16	1-3/8 - 6 UNC	655 (887)	1470 (1992)	2382 (3228)
2-1/16	1-3/8 - 12 UNF	746 (1011)	1672 (2266)	2712 (3675)
2-1/4	1-1/2 - 6 UNC	870 (1179)	1950 (2642)	3161 (4283)
2-1/4	1-1/2 - 12 UNF	979 (1327)	2194 (2973)	3557 (4820)

METRIC

Recommended torque in foot pounds (newton Meters).*

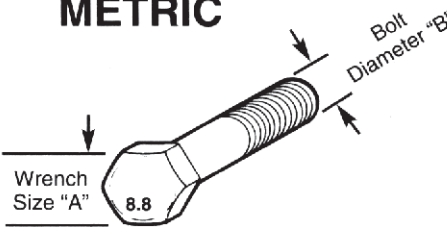

Numbers appearing on bolt heads indicate ASTM class.

WRENCH SIZE (mm) "A"	BOLT DIA. (mm) "B"	ASTM 4.6	ASTM 8.8	ASTM 9.8	ASTM 10.9
8	5	1.8 (2.4)		5.1 (6.9)	6.5 (8.8)
10	6	3 (4)		8.7 (12)	11.1 (15)
13	8	7.3 (10)		21.1 (29)	27 (37)
16	10	14.5 (20)		42 (57)	53 (72)
18	12	25 (34)	74 (100)	73 (99)	93 (126)
21	14	40 (54)	118 (160)	116 (157)	148 (201)
24	16	62 (84)	167 (226)	181 (245)	230 (312)
30	20	122 (165)	325 (440)		449 (608)
33	22		443 (600)		611 (828)
36	24	211 (286)	563 (763)		778 (1054)
41	27		821 (1112)		1138 (1542)
46	30	418 (566)	1119 (1516)		1547 (2096)

*Use 75% of the specified torque value for plated fasteners. Use 85% of the specified torque values for lubricated fasteners.

NOTES



**10 WALDEN DRIVE
ARDEN, NORTH CAROLINA 28704
(800) 438-5823 OR (828) 684-1234 FAX: (828) 684-0858
EMAIL: peco@lawnvac.com
WEBSITE: www.lawnvac.com**