



# PTO GRASS COLLECTION SYSTEM

2012-2014 MODEL YEAR

**FREEDOM Z**  
Made in the USA by **SCAG**

61" Commercial  
Deck



**MODEL #: 37621231  
PTO DRIVE**

**MODEL #: 37621232  
900 SERIES BRIGGS & STRATTON**

**MODEL #: 37621233  
6.5HP BRIGGS & STRATTON  
VANGUARD**

## **OPERATOR'S MANUAL**

**ASSEMBLY • OPERATION • MAINTENANCE**

# PECO GRASS COLLECTION SYSTEM

## TABLE OF CONTENTS

SECTION	PAGE	SECTION	PAGE
Safety -----	2	2-18 Blower Cone Installation -----	14
Safety Alert Symbols-----	3	2-19 Boot To Mower Deck Installation-----	14
Warranty -----	4	2-20 Length of Hose Adjustment -----	15
I INTRODUCTION AND DESCRIPTION -----	5	2-21 Upper Hose Installation -----	15
1-1 Introduction -----	5	2-22 Lower Hose to Blower Cone Installation -----	15
1-2 Description -----	5	2-23 Lower Hose to Boot Installation -----	15
II INSTALLATION FOR USE -----	6	2-24 Impeller Blade Removal Replacement -----	16
2-1 Preparation Of Mower -----	6	2-25 Weight Kit Installation-----	17
2-2 Rt. & Lt. Lower Frame Plate Installation -----	6	2-26 Throttle Cable Installation -----	18
2-3 Rear Lower Frame Plate Installation -----	7	Exploded Views and Parts List -----	19-24
2-4 Heat Guard Installation-----	7	III OPERATING INSTRUCTIONS -----	25
2-5 Upper Frame Assembly Installation-----	7	3-1 General Safety -----	25
2-6 Exhaust Diverter Installation -----	7	3-2 Operation & Tips On Mowing-----	25
2-7 Lift Handle Installation -----	8	3-3 Disengagement Of The Blower -----	25
2-8 Aluminum Grass Container Installation -----	9	3-4 Unloading The Collection System-----	25
2-9 Dump Mechanism Adjustment -----	9	IV MAINTENANCE -----	25
2-10 PTO Mount Plate Component Installation-----	10	4-1 Maintenance Checklist -----	25-26
2-11 PTO Assembly Installation-----	11	4-2 Lubrication-----	26
2-12 Belt Installation & Adjustment -----	12	V PARTS AND SERVICE -----	26
2-13 PTO Handle Assembly Installation -----	13	5-1 Parts And Service Information -----	26
2-14 Cam Assembly Adjustment -----	13	Safety Decals -----	27
2-15 Outer Engine Mount Tube Installation -----	13	Torque Specifications -----	28
2-16 Engine Mount Arm Assembly Installation -----	13		
2-17 Engine/Blower/Blade Assembly Installation-----	14		

### Safety

- 1.** Read the operator's manual carefully and familiarize yourself with the proper use of your attachment. Do not allow anyone who is not acquainted with the Safety Instructions to use your attachment.
- 2.** Know the controls and how to stop quickly. **READ THE OPERATOR'S MANUAL!**
- 3.** Do not allow children to operate the vehicle. Do not allow adults to operate it without proper instruction.
- 4.** Be especially watchful of children and pets darting into the area while operating.
- 5.** Keep your eyes and mind on your unit while mowing or operating your attachment. Don't let others distract you.
- 6.** Do not attempt to operate your unit or mower when not in the driver's seat.
- 7.** Always stop unit when emptying the container.
- 8.** Stop unit, shut off deck attachment, set parking brake, shut off mower engine and remove spark plug wire before removing clogs, removing or replacing hose, boot, blower cone, or performing any maintenance.
- 9.** Mow up and down the face of slopes (not steeper than 10 degrees); never up and down the face of the slope.
- 10.** It is recommended that the container be kept only half full when negotiating any slopes. Start mowing on slopes when the container is empty.
- 11.** Inspect your lawn and remove any foreign objects before mowing. Never deliberately run the mower across any foreign object.
- 12.** Wear ear protection if the noise level is offensive.
- 13.** Wear eye protection to prevent debris from damaging your eyes.

# SAFETY

**WARNING!** **NEVER** operate the mower unless the discharge guard and either the deflector assembly or the vacuum collector adapter are fastened securely in place.

**WARNING!** Do not work around the mower deck boot or the blower area until you are certain that the mower blades and the blower impeller have stopped rotating.

**WARNING!** To avoid serious injury, perform maintenance on the vacuum collector; **ONLY AFTER STOPPING THE MOWER'S ENGINE AND WAITING FOR ALL MOVING PARTS TO COME TO A COMPLETE STOP.** Set the parking brake. Always remove the ignition key before beginning maintenance.

**WARNING!** For your own personal safety, **ALWAYS** mow **ACROSS** the face of slopes and **NEVER UP and DOWN** the face. **NEVER** attempt to mow excessively steep slopes, and use caution when turning on any slope.

## Safety Alert Symbol



This Safety Alert Symbol means: **“ATTENTION! BECOME ALERT! YOUR SAFETY IS INVOLVED!”**

This symbol is used to call attention to safety precautions that should be followed by the operator to avoid accidents. When you see this symbol, carefully read the message that follows and heed its advice. Failure to comply with safety precautions could result in death or serious bodily injury.

## Safety Signs

The signal words **DANGER**, **WARNING**, and **CAUTION** are used on the equipment safety signs. These words are intended to alert the viewer to the existence and the degree of hazard seriousness.



White letters on **RED**

This signal word indicates a potentially hazardous situation which, if not avoided, will result in death or serious injury.



Black letters on **ORANGE**

This signal word indicates a potentially hazardous situation which, if not avoided, could result in death or serious injury.

It may also be used to alert against unsafe practices.



Black letters on **YELLOW**

This signal word indicates a potentially hazardous situation exist which, if not avoided, will result in minor or moderate injury.

It may also be used to alert against unsafe practices.

# PECO LIMITED WARRANTY FOR NEW PRODUCTS

## A. WHAT IS UNDER WARRANTY?

PECO extends the following warranties to the original purchaser of each new PECO consumer product subject to the following limitations.

**1. PRODUCT WARRANTY:** Any part of any consumer product, which is defective in material or workmanship as delivered to the purchaser will be repaired or replaced, as PECO elects, without charge for parts or labor, if the defect appears within 12 months from the date of delivery of the product to the original purchaser.

**ALL DEFECTIVE PARTS MUST BE RETURNED TO PECO FOR INSPECTION TO DETERMINE VALIDITY OF WARRANTY CLAIMS.** Freight and mailing will be borne by the customer.

**2. PARTS REPLACED DURING WARRANTY:** Any new PECO part which is furnished in performance of this warranty and is defective in material or workmanship as delivered to the purchaser will be repaired or replaced, as PECO elects, without charge if the defect appears within 90 days from the date of installation of such part or before the expiration of the original warranty period, whichever is later.

## B. SECURING WARRANTY ADJUSTMENTS.

Call PECO for Return Authorization. Damaged or broken parts other than engines or batteries, must be returned to New PECO, Inc. 100 Airport Road, Arden, NC 28704 before any warranty adjustment can be authorized. At the time of requesting warranty adjustment, the purchaser must present evidence of the date of delivery of the product. The purchaser shall pay any charge for the product to and from Arden, NC.

## C. ITEMS NOT COVERED BY PECO WARRANTY.

Engines and batteries attached to PECO products are covered under a separate warranty by the respective manufacturer.

## D. UNAPPROVED ALTERATION OR MODIFICATION.

All obligations of New PECO, Inc. under this warranty shall be terminated if products are altered or modified in ways not approved by New PECO, Inc.

## E. ACCIDENTS AND NORMAL MAINTENANCE.

The warranty covers only defective material and workmanship. It does not cover depreciation or damage caused by normal wear, accident, improper use or abuse of products. The cost of normal maintenance and normal replacement of service items such as belts, cutting blades, hoses, etc., which are not defective shall be paid for by the purchaser.

## F. NO REPRESENTATIONS ADDITIONAL WARRANTIES, DISCLAIMER.

Neither New PECO, Inc. nor any company affiliated with it makes any warranties, representations or promises as to the quality of performance of its products other than those set forth herein. Except as described above, New PECO, Inc. makes no other warranties **AND SPECIFICALLY DISCLAIMS ANY AND ALL IMPLIED WARRANTIES OF FITNESS AND MERCHANTABILITY.**

## G. ANY MACHINE USED FOR RENTAL PURPOSES ARE GUARANTEED FOR 45 DAYS FROM DATE OF ORIGINAL SALE ONLY.

## H. REMEDIED EXCLUSIVE.

The only remedies the purchaser has in connection with the breach or performance of any warranty on New PECO, Inc. consumer products are set forth above. In no event will PECO be liable for special incidental or consequential damages.

## 1. NO SERVICE CENTER WARRANTY.

The selling Service Center makes no warranty on his own on any item warranted by New PECO, Inc. unless he delivers to purchaser a separate written warranty certificate specifically warranting the item. The dealer has no authority to make any representation or promise on behalf of PECO or to modify the terms of this warranty in any way.

# Section I - INTRODUCTION AND DESCRIPTION

## 1-1 Introduction

We are pleased to have you as a PECO customer. Your collection system has been designed to give you a low maintenance, simple, and effective way to collect the grass clippings from your mower. This manual is provided to give you the necessary instructions to properly mount and operate the collection system on your mower. Please read this manual thoroughly. Understand what each control is for and how to use it. Observe all safety decal precautions on the machine and noted throughout the manual.

**NOTE:** all references made to right, left, front, rear, top or bottom are as viewed from the normal operator's position on the mower.

## 1-2 Description

The grass collection system is designed for turf maintenance where there is a need to collect the grass clippings as the mower cuts the turf. It is also used for picking up leaves and in pre-season and post-season clean-up. The blower, mounted on the right side of the unit, uses a belt and gearbox system from the engine PTO shaft. Drive train protection comes through belt slippage. The blower is also available with an external engine option of 5.5HP or 6.5HP. The blower draws grass clippings from the discharge area of the cutter deck back to the 12 cubic foot aluminum box at the rear portion of the mower frame. The operator can engage the blower with a push of the over-center linkage on the right side of the unit, or starting the external engine. Once the bags are full with clippings, they can be released to make for easy dumping.

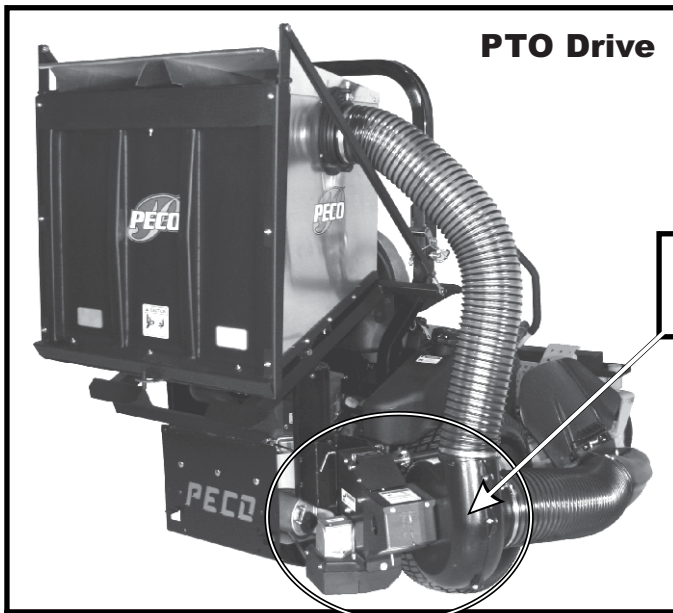

**Universal PTO  
Assembly P#(A0623)**

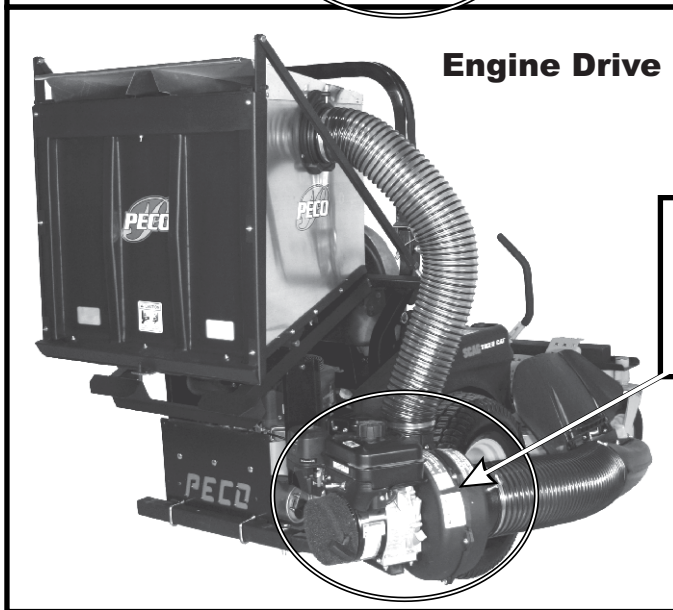

**Engine/Blower/Blade Assembly  
5.5HP Briggs and Stratton P#(A602)  
or  
Engine/Blower/Blade Assembly  
6.5HP Briggs and Stratton P#(A639)**

## Section II INSTALLATION FOR USE

### 2-1 Preparation Of Mower

Remove the rear bumper from the mower frame. There are (8) 3/8" hex bolts that secure the rear bumper to the mower frame. Save this hardware for use later in the installation. See Figure 2-1a.

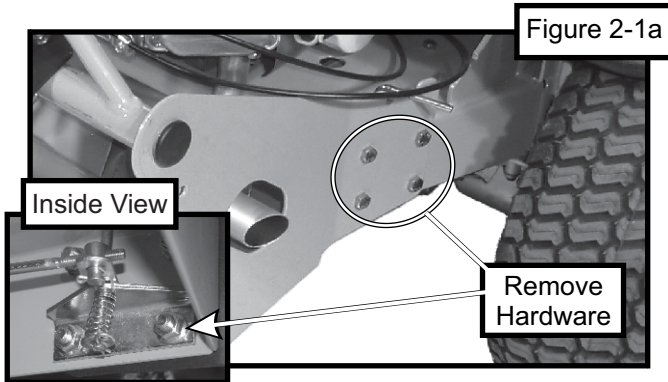

Next, check the exhaust direction, as if sitting in the Operator's Seat. If the exhaust is blowing to the Right-Hand Side, disassemble and reassemble the Diverter to point to the Left-Hand Side before continuing.

From the underside of the engine, remove the bolt and bushing from the electric clutch assembly. Use a bungee cord or similar device to hold the clutch in place while the hardware is removed.

Replace the hardware removed with the engine pulley assembly number 13 P#(A0732). Fasten the engine pulley to the electric clutch assembly using (1) 7/16" hi-collar helical spring lock washer P#(K0140) and (1) 7/16"-20 x 3-3/4" HHCS P#(K0350). See Figure 2-1b for details.

The added pulley will power the collection system.  
Torque the bolt to 55 ft./lbs.

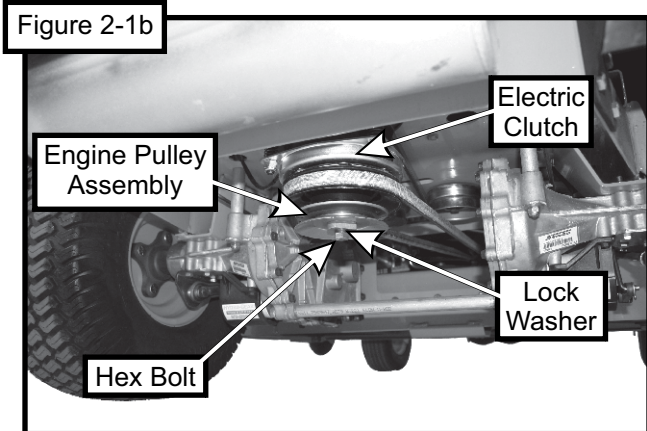

### 2-2 Right and Left Lower Frame Plate Installation

Fasten the right lower frame plate P#(B0730) to the rear frame of the mower using the (4) existing 3/8"-16 hex bolts and (4) 3/8"-16 nuts from the right rear bumper. Leave the hardware slightly loose until the heat guard from section 2-4 has been installed. Refer to Figure 2-2a.

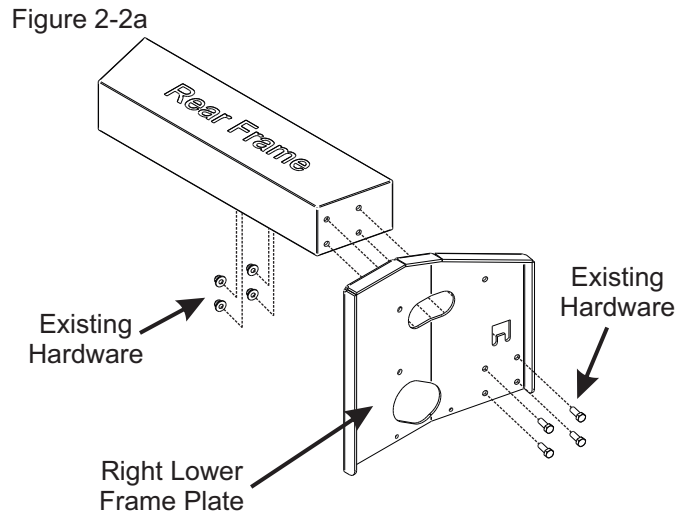

Fasten the left lower frame plate P#(B0729) to the rear frame of the mower using the (4) existing 3/8"-16 hex bolts and (4) 3/8"-16 nuts from the right rear bumper. Leave the hardware slightly loose until the heat guard from section 2-4 has been installed. Refer to Figure 2-2b.

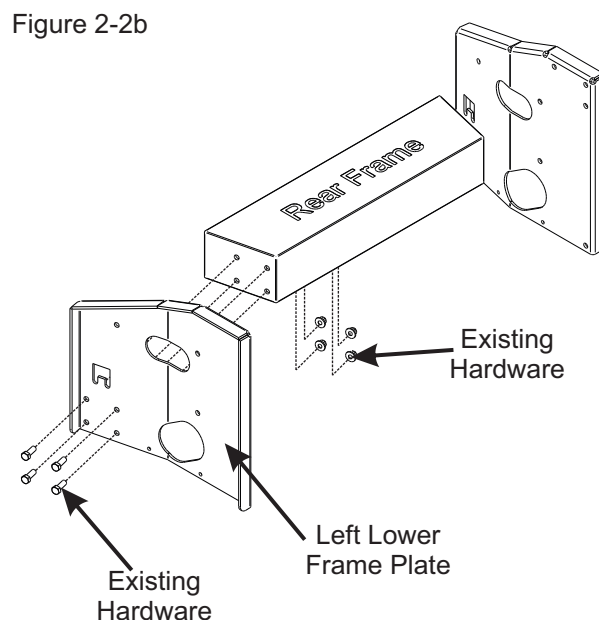

## 2-3 Rear Lower Frame Plate Installation

Fasten the rear lower frame plate P#(B0728) to the left and right lower frame plate using (2) 3/8"-16 x 1" HHCS P#(K1191) and (2) 3/8"-16 nylon flange locknuts P#(K2038). Leave hardware slightly loose until the heat guard from section 2-4 has been installed. Refer to Figure 2-3.

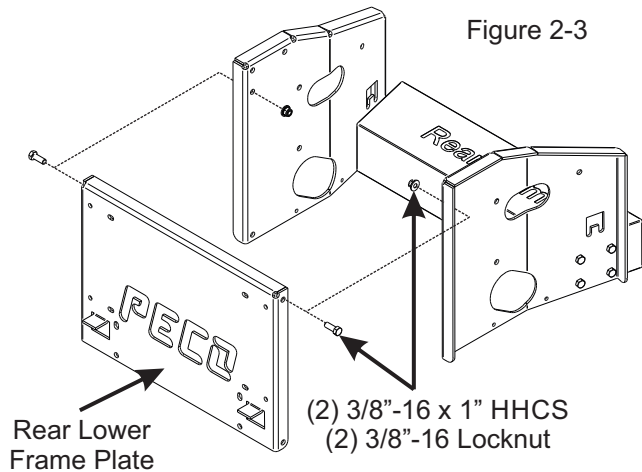

## 2-4 Heat Guard Installation

Secure front holes of heat shield P#(B0890) to left lower frame plate and right lower frame plate, using (2) 1/4"-20 x 3/4" HHCS P#(K1222), (2) 1/4"-20 nylon flange locknuts P#(K2014) and (4) 1/4" Flat Washers P#(K0037). Secure rear holes using (2) 3/8"-16 x 1" HHCS P#(K1191) and (2) 3/8"-16 nylon flange locknuts P#(K2038). Once the heat shield has been installed, tighten all frame plate hardware. Refer to Figure 2-4.

Figure 2-4

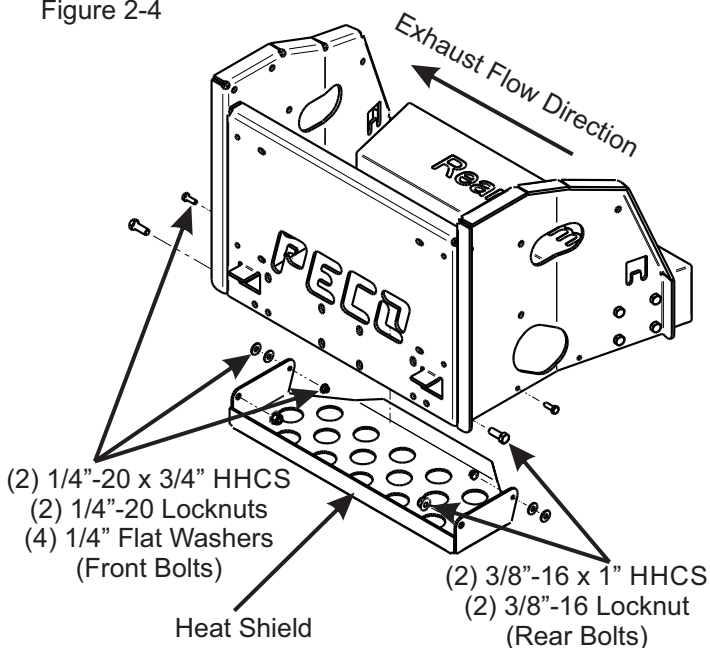

## 2-5 Upper Frame Assembly Installation

Lift the main frame assembly P#(A0658) into position above the left and right lower frame legs. Secure the main frame assembly to the lower frame legs using (4) 3/8"-16 x 1" HHCS P#(K1191) and (4) 3/8"-16 nylon flange locknuts P#(K2038). Refer to Figure 2-5.

Figure 2-5

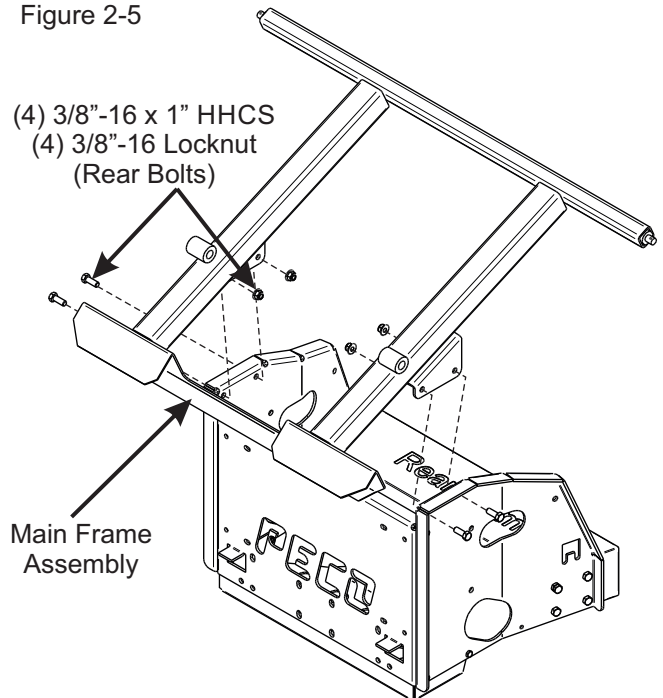

## 2-6 Exhaust Diverter Installation

Insert the exhaust deflector P#(J0251) onto the end of the muffler. Orientate the exhaust diverter to exhaust towards the rear of the mower, slightly downward to avoid burning the cloth bags or the grass. Secure the exhaust diverter with (1) exhaust clamp kit P#(X1046). Refer to Figure 2-6.

Figure 2-6

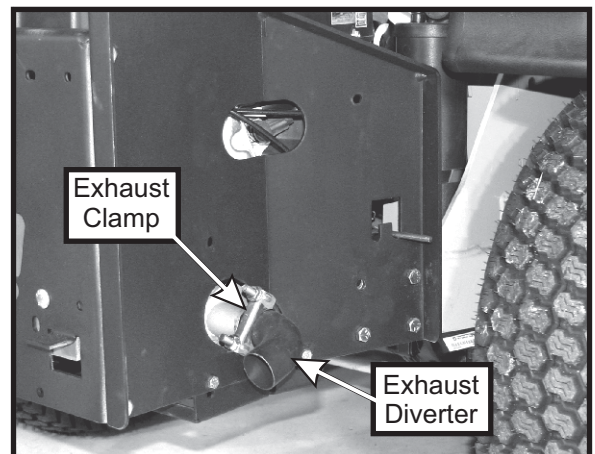

## 2-7 Lift Handle Installation

**NOTE:** Before continuing the lift handle installation, have someone assist you in turning the grass container upside down. Insert (1) 3/8"-16 x 2" HHCS P#(K1208) into the lift handle P#(A0273), and secure with (1) 3/8"-16 flange nut P#(K1215). Thread the flange nut onto the bolt upside down, as shown in Figure 2-7a. Do not tighten the nut fully at this time.

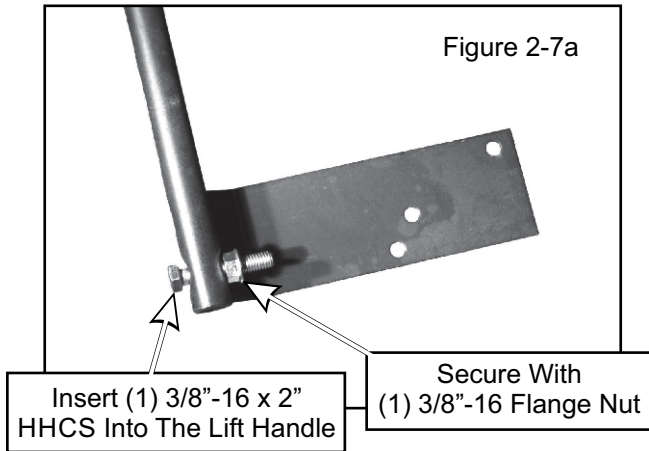

Slide the lift handle through the slot on the handle mount bracket. Insert the lift handle into the box frame as shown in Figure 2-7b, and secure using (1) 3/8"-16 flange nut P#(K1215) on the inside of the container as shown in Figure 2-7c. Now test the movement of the handle. It should have full-range of movement in the slot. If the handle does not have full-range of movement, adjust the 3/8"-16 flange nut from step 2-7a. Once achieved, tighten the fasteners.

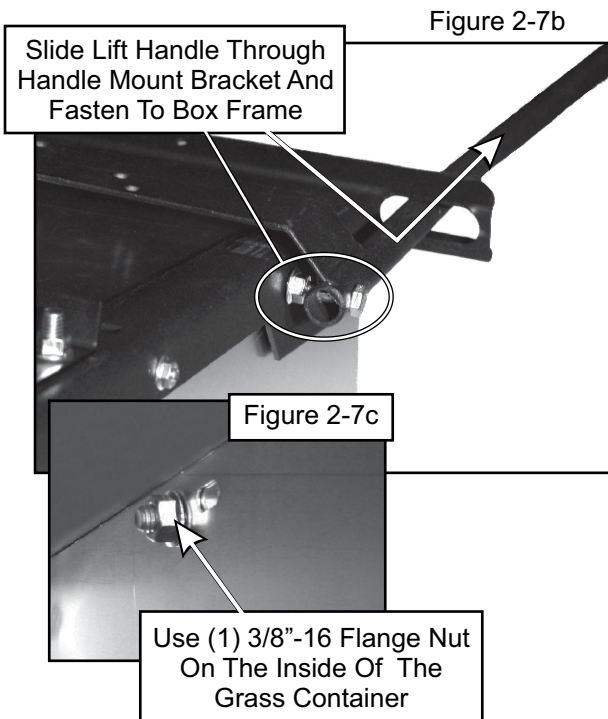

Fasten the ball joint P#(K1442) to the end of the latch rod P#(A0620). Tighten the ball joint to approximately half way down the threads on the latch rod. Attach the ball joint to the latch hook as shown in Figure 2-7d, using (1) 5/16"-24 hex nut P#(K1444) and (1) 5/16" lock washer P#(K0043).

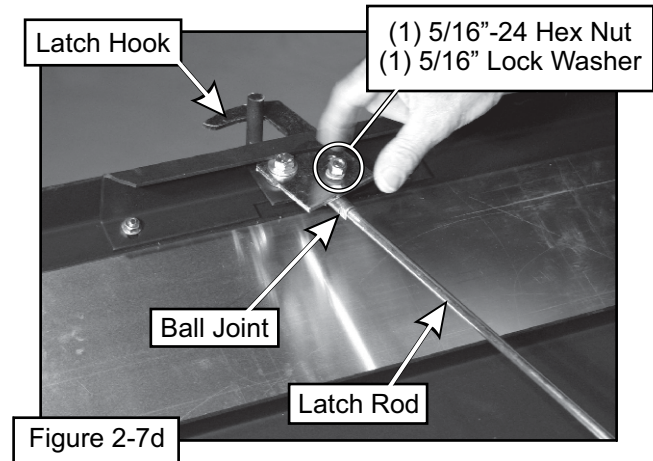

Attach the other end of the latch rod to the lift handle, as shown in Figure 2-7e. Attach one end of the spring P#(J0176) to the lift handle and the other end of the spring to the handle mount bracket as shown in Figure 2-7f. Adjust the ball joint up or down on the latch rod threads until the latch hook closes completely. After adjusting the latch hook, secure the latch rod to the lift handle using (1) cotter pin P#(K0094).

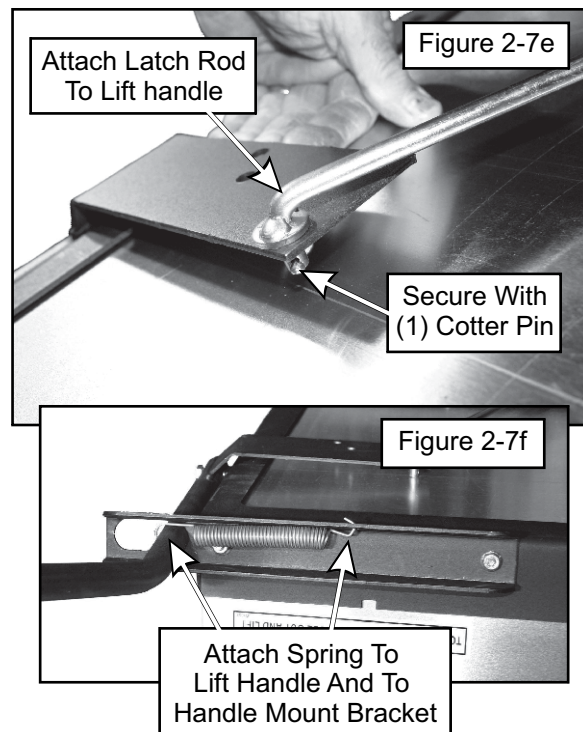



## 2-8 Aluminum Grass Container Installation

**NOTE:** It is recommended that (3) people assist in mounting the container. With three people available, two can lower the container onto the frame while the third person inserts the pivot pins P#(K0172) through the holes. Insert the pins from the outside to the inside. Secure with (1) 5/8" washer P#(K0058) and (1) 5/32" x 2-5/8" hair pin clip P#(K0088) per pivot pin (Figure 2-6b). Reattach the bottom ends of the door opening linkages to the main frame by using (1) Rue-Ring cotter pin P#(K1437) per side. To test the functionality of the dump mechanism, pull the lift handle away from the unit, and lift upward. The door of the container should open and the box should pivot clockwise towards the ground.

Figure 2-8a

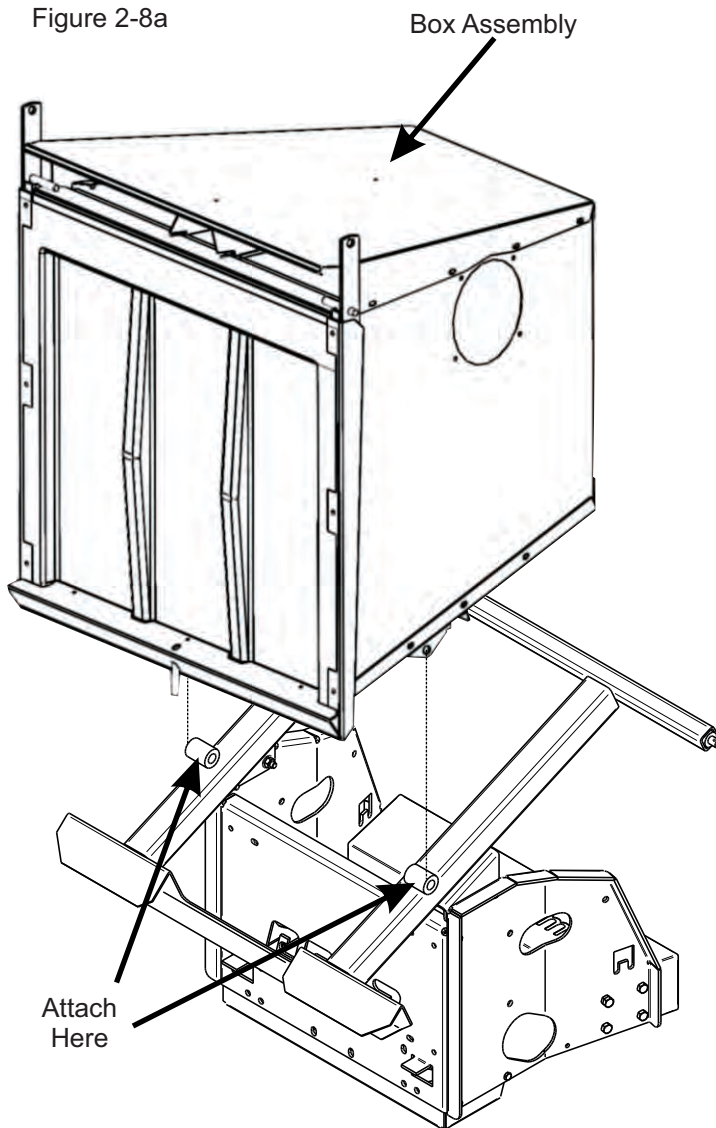
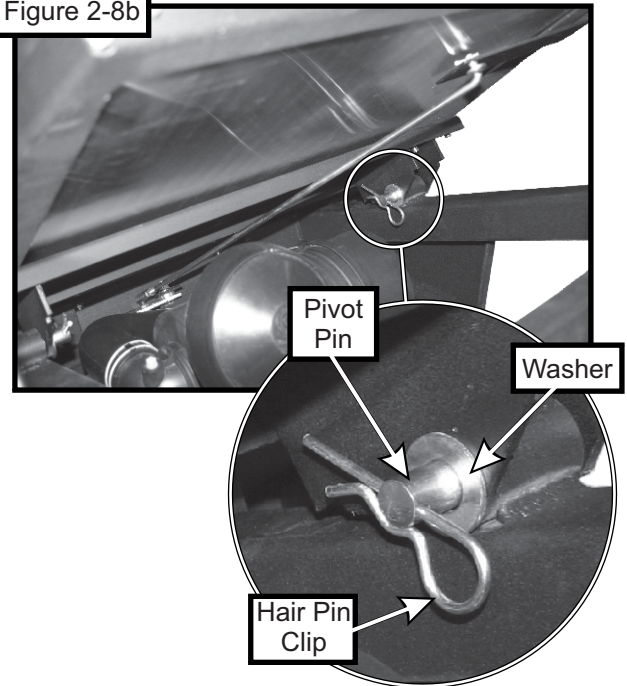
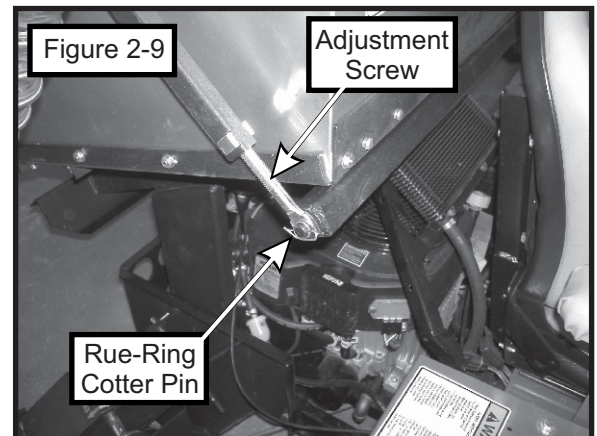

Figure 2-8b



## 2-9 Dump Mechanism Adjustment

The linkage may be adjusted in two places, at the adjusting screw P#(K1435) and the latch assembly items. See page 20 for visual clarification. To change the door closure tightness, screw the adjusting screw (Figure 2-9) in or out. To adjust the latch, change the length of the latch rod by screwing the latch adjusting ball joint in or out. The latch hook pivot should be in the middle of the slot in the latch hook pivot plate. Slide the pivot back or forth and then re-tighten.



## 2-10 PTO Mount Plate Component Installation (PTO MODELS ONLY)

Secure the left PTO mount plate P#(B0734) to the right lower frame plate using (2) 3/8"-16 x 1" HHCS P#(K1191) and (2) 3/8"-16 nylon flange locknuts P#(K2038). Leave the hardware slightly loose until the PTO stop plate has been installed. Refer to Figure 2-10a.

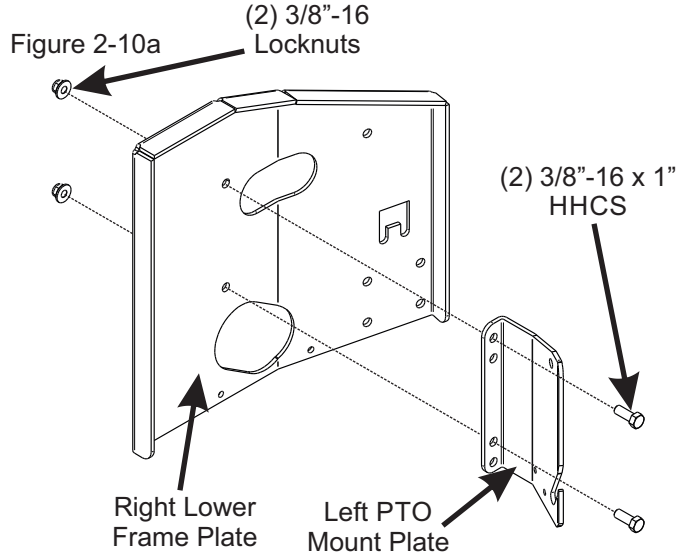

Secure the right PTO mount plate P#(B0735) to the right lower frame plate using (2) 3/8"-16 x 1" HHCS P#(K1191) and (2) 3/8"-16 nylon flange locknuts P#(K2038). Leave the hardware slightly loose until the PTO stop plate has been installed. Refer to Figure 2-10b.

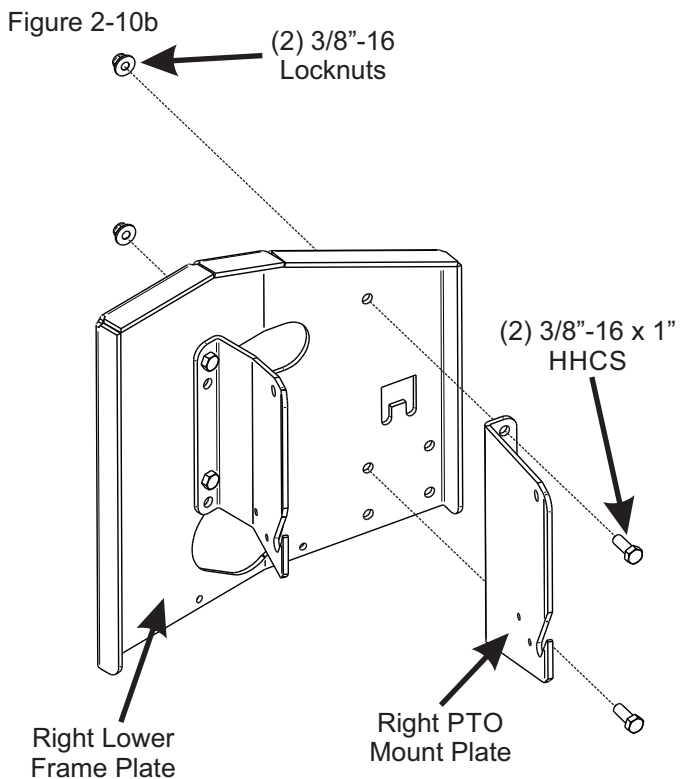

Secure the PTO stop plate P#(B0736) to the left and right PTO mount plates using (4) 1/4"-20 x 3/4" HHCS P#(K1222) and (4) 1/4"-20 nylon flange locknuts P#(K2014). With the stop plate secured, tighten all PTO mount plate component hardware at this time. Refer to Figure 2-10c.

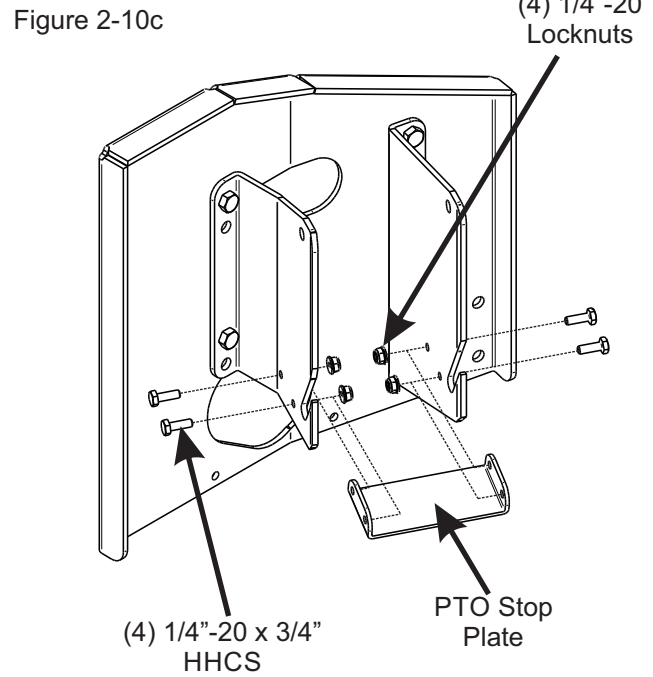
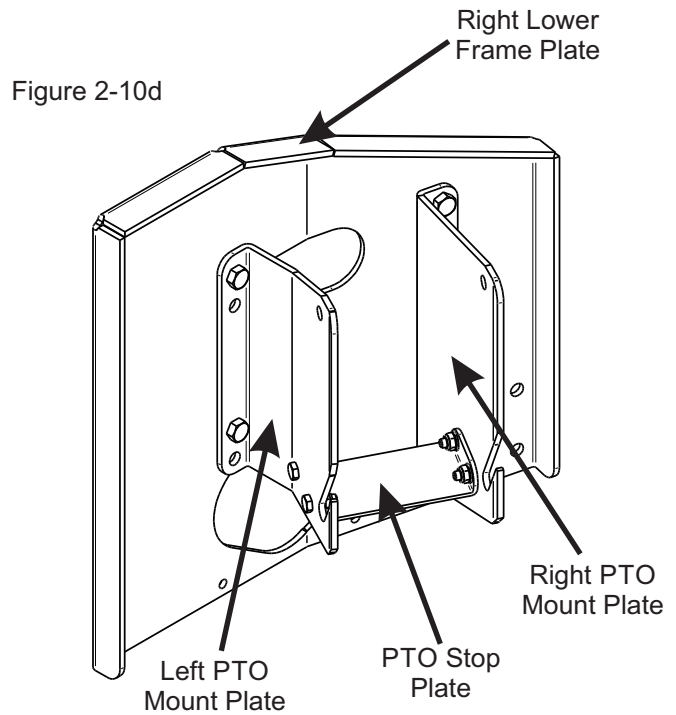

Figure 2-10d shows the complete PTO mount plate assembly as it should be assembled on your mower.



## 2-11 PTO Assembly Installation

### PTO MODELS ONLY

Insert the PTO assembly P#(A0623) into the PTO mount plate assembly as shown in Figure 2-11a. The mount rod on the PTO assembly slides into the mounting slots on the PTO mount plate assembly. Secure the PTO assembly with (1) mount pin P#(B0274) and (1) hair pin clip P#(K0086) shown in Figure 2-11b. Remove the pulley guard in preparation for the belt installation.

Figure 2-11a

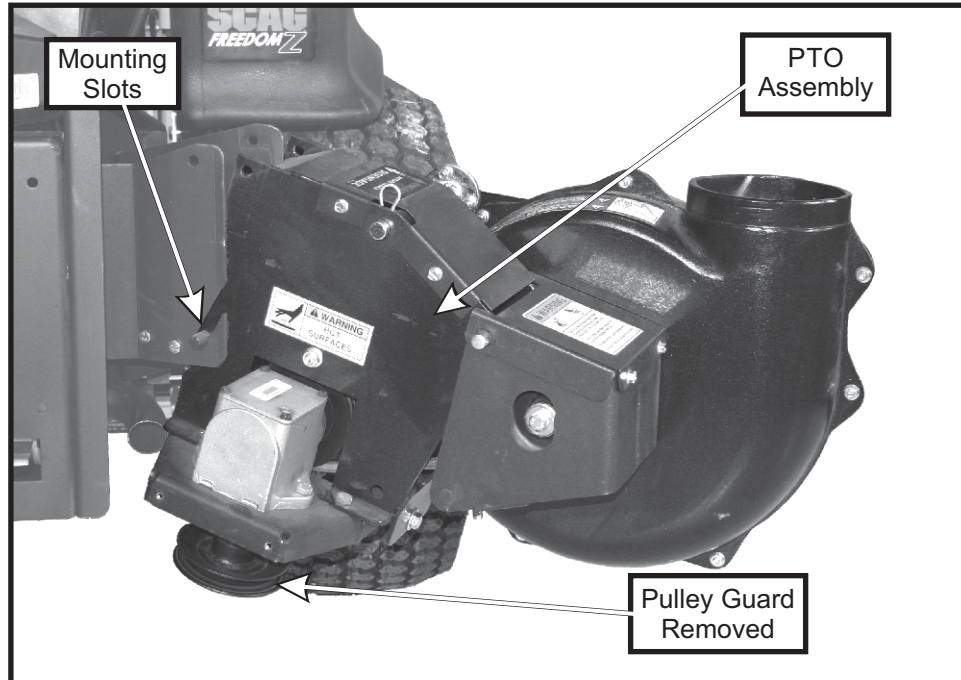
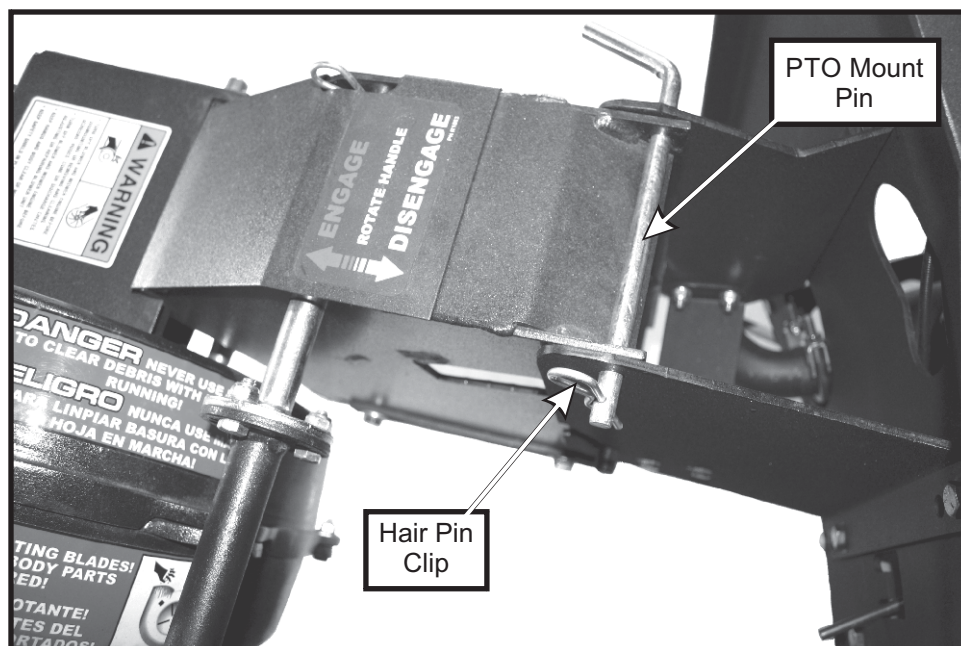

Figure 2-11b



## 2-12 Belt Installation and Adjustment PTO MODELS ONLY

Loosen the (4) bolts P#(K1191), (2) on each side, that secure the gear box assembly to the PTO assembly P#(A0623) (Figure 2-12a and 2-12b).

Figure 2-12a

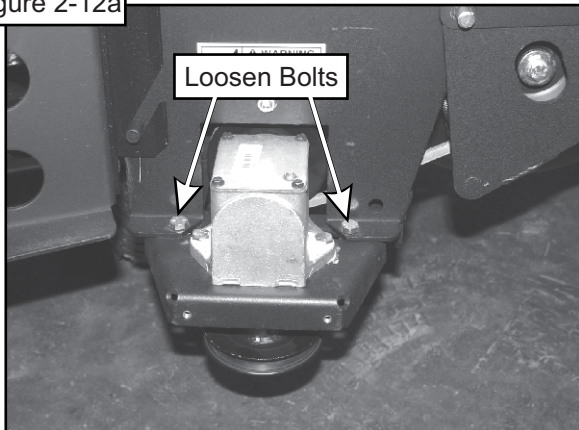
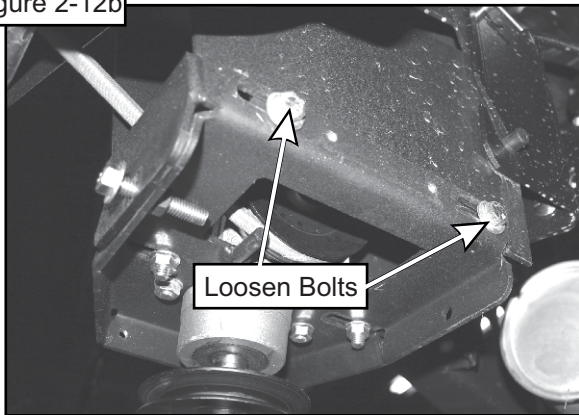
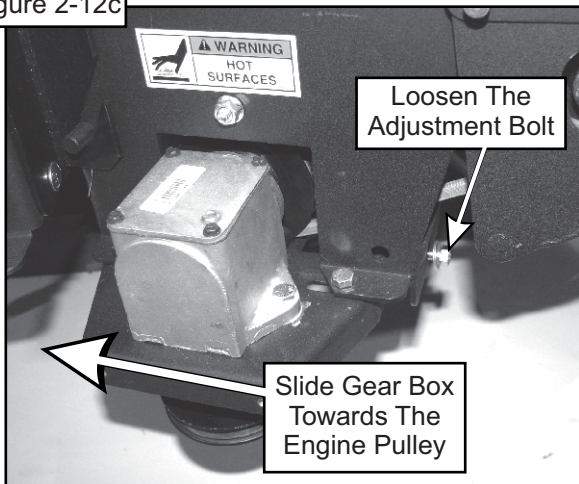

Figure 2-12b



Loosen the adjustment bolt P#(K0348) until the gear box assembly is at its far left adjustment (the gear box is moved toward the mower's engine pulley). Refer to Figure 2-12c.

Figure 2-12c



Connect the belt A55K P#(M0248) from the engine pulley to the lower gear box pulley (Figure 2-12d).

Figure 2-12d

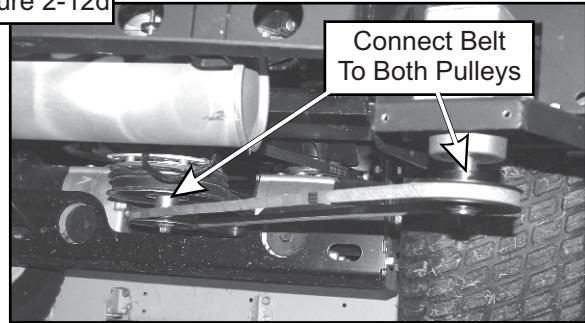

To tension the drive belt, turn the adjustment bolt clockwise (Figure 2-12e) until there is 1" of deflection, with 10-11 lbs. of pressure, at the center of the belt between the engine pulley and the gear box pulley.

Figure 2-12e

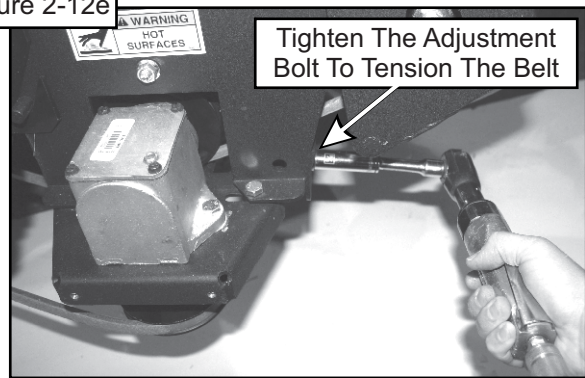

Once the correct tension of the belt is achieved, tighten the (4) bolts that secure the gear box assembly. Refer to Figures 2-12f and 2-12g. Replace the belt guard and hardware that was removed in Section 2-11.

Figure 2-12f

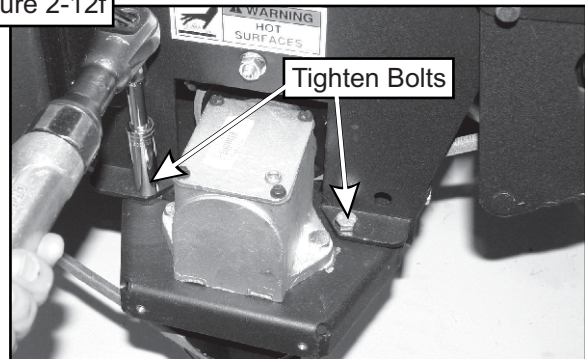
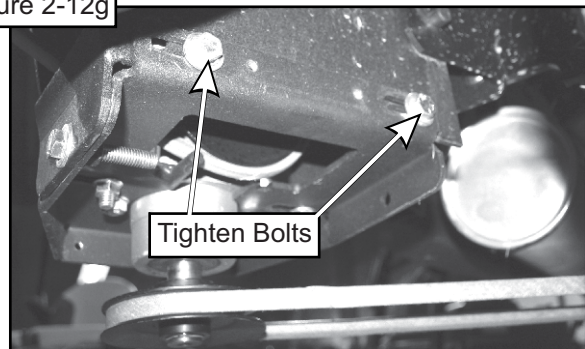

Figure 2-12g



## 2-13 PTO Handle Assembly Installation

### PTO MODELS ONLY

Attach the PTO handle P#(A1142) to the PTO assembly using (3) 1/4"-20 x 3/4" HHCS P#(K1222) and (3) 1/4"-20 nylon flange locknuts P#(K2014). Attach the handle grip P#(J0522) to the PTO handle. Refer to Figure 2-13.

Figure 2-13

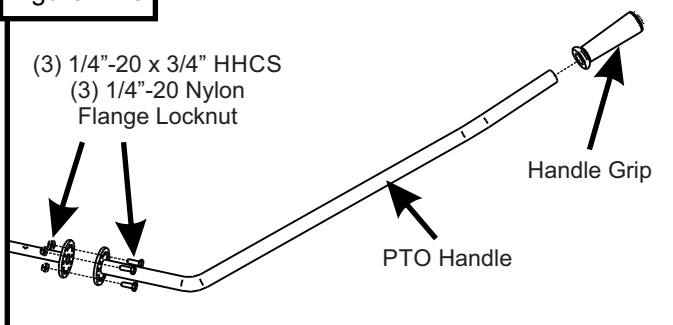

## 2-14 Cam Assembly Adjustment

### PTO MODELS ONLY

The cam assembly P#(A0422), which controls the blower belt tension, comes from the factory pre-adjusted. If the belt is too tight or becomes too loose, remove the hair pin clip P#(K0099) from the belt tension rod P#(K0326) and pull the "L" end of the rod out of its hole in the cam assembly. The tension rod may then be screwed out to tighten the belt or screwed in to loosen the belt. Replace the "L" end into the top hole in the cam and replace the hair pin clip. Adjust the cam stop bolt P#(K1159) to allow the cam to rotate slightly over center when the blower is disengaged (Figure 2-14).

Figure 2-14

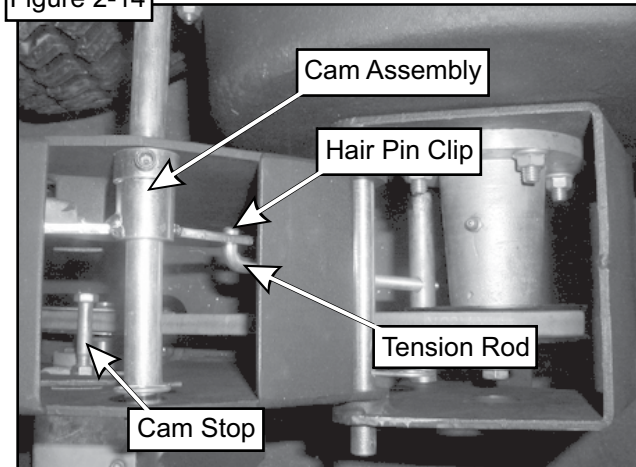

## 2-15 Outer Engine Mount Tube Installation

Position the outer engine mount tube P#(B1117) as shown in Figure 2-15. Secure the outer engine mount tube to the lower mount plate using (2) 3/8"-16 x 2-18" u-bolt P#(K1119) and (4) 3/8"-16 nylon flange lock nuts P#(K2038). Orient the tube so that the detent pin mount hole is to the outside. Leave hardware finger tight until the engine/blower/blade assembly has been installed.

Figure 2-15

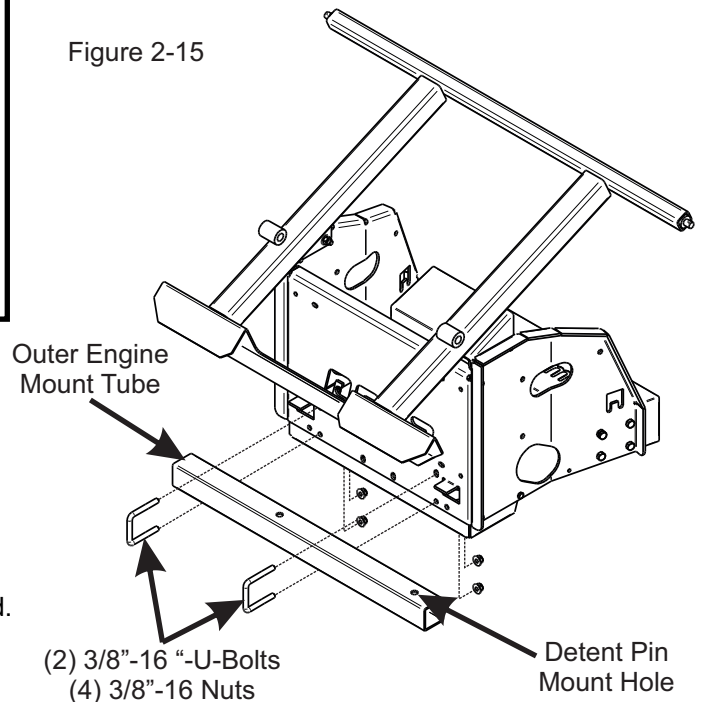

## 2-16 Engine Mount Arm Assembly Installation

Insert the engine mount arm assembly P#(A1824) into the outer engine mount tube and secure using (1) detent pin P#(J0248). Refer to Figure 2-16.

Figure 2-16

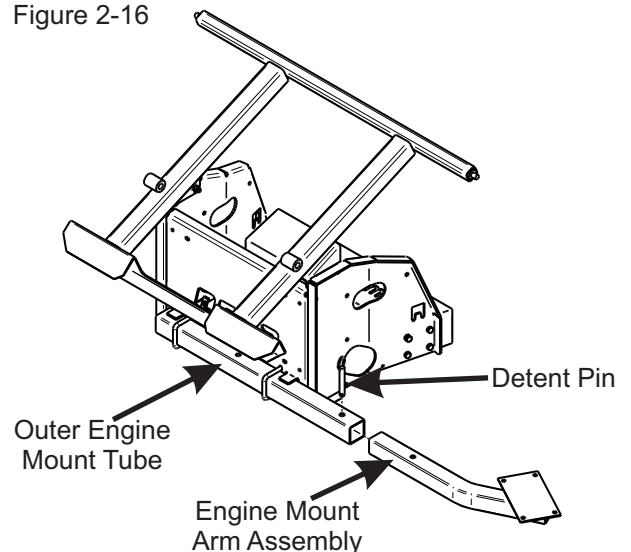

## 2-17 Engine/Blower/Blade Assembly Installation

Place the engine blower blade assembly on top of the engine mount arm as shown in Figure 2-17A. Secure the assembly using (4) 5/16"-18 x 1-1/2" HHCS P#(K1157) and (4) 5/16"-18 nylon flange lock nuts P#(K2516) as shown in Figure 2-17b. Tighten all hardware in Section 2-16.

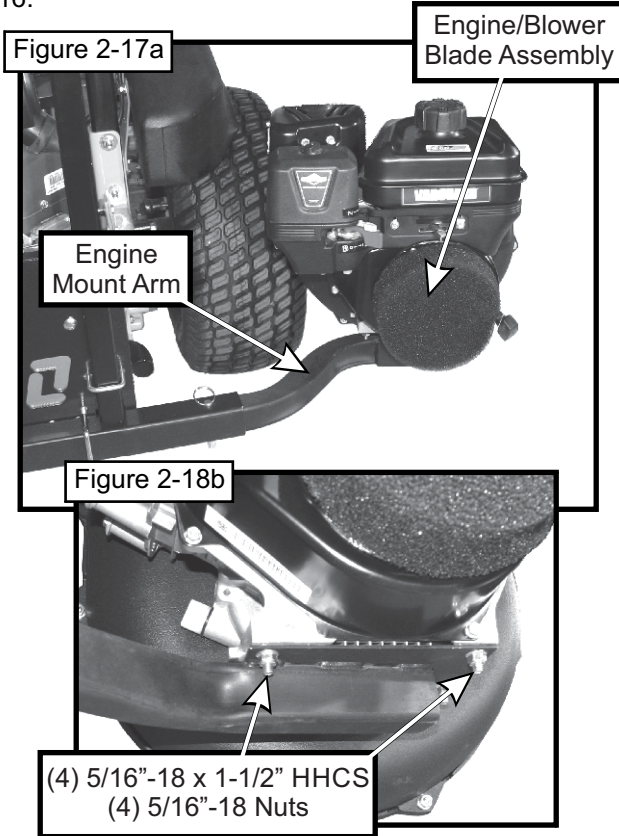

## 2-18 Blower Cone Installation

Thread (1) 5/16"-18 jam nut P#(K0120) onto each end of (2) 5/16"-18 x 2-1/2" HHCS P#(K0125). Now partially thread the bolts into each of the two tabs located on the blower housing. Place blower cone so the two tabs line up with the bolts then tighten completely (Figure 2-18).

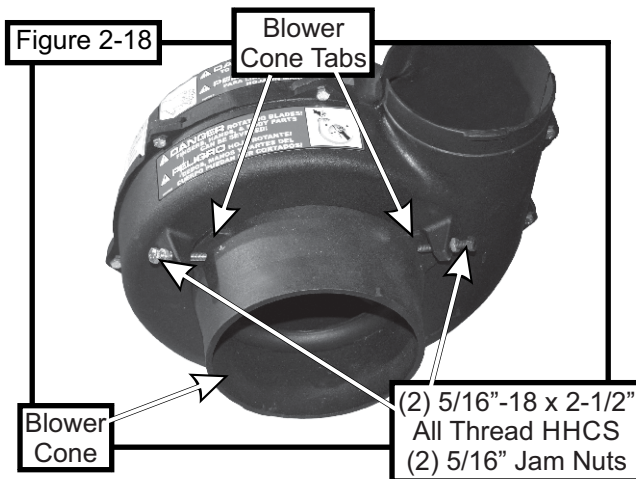

## 2-19 Boot To Mower Deck Installation

Position the boot plate P#(B0751) on top of the aluminum boot P#(E1047) as shown in Figure 2-19a. Secure the boot plate to the boot using (2) 3/8"-16 x 1" carriage bolts P#(K1182) and (2) 3/8"-16 nylon flange lock nuts P#(K2038). Insert the bolts from the inside of the boot so that the threads are on the outside of the boot. This will prevent any grass clippings from collecting on the threads. To attach the boot to the mower deck, lift the grass deflector and hook the tabs on the boot plate under the deflector hardware as shown in Figure 2-19b.

Figure 2-19a

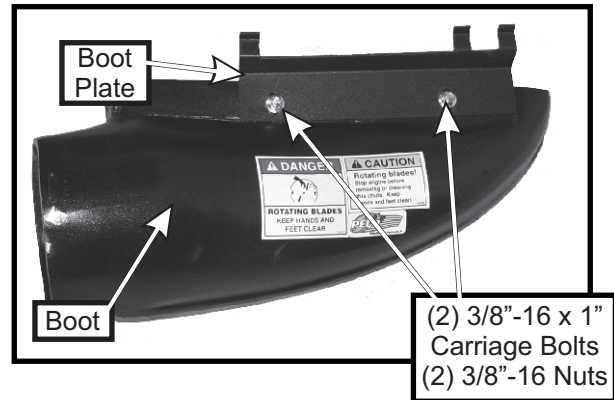
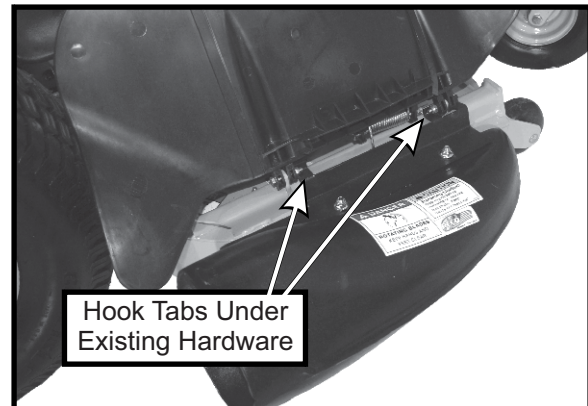

Figure 2-19b



## 2-20 Length Of Hose Adjustment

The hoses in steps 2-21 and 2-22 must be cut to fit your machine. Follow steps 2-21 and 2-22. do not cut the hoses until you have tried to fit them on your machine. Remember that the hoses have to be long enough to adjust for the blower assembly's movement as well as allow for enough clamping surface between the inlet, blower assembly, and the deck boot.

## 2-21 Upper Hose Installation

Slide a pre-assembled hose clamp P#(J0060) onto both ends of the 6" upper hose (Figure 2-23). Then slide one end of the 6" hose onto the 6" hose ring P#(E0007). Make sure there is about a two-inch overlap between the hose end and the hose ring. Lift the locking pin on the 7" inlet ring P#(V1152) and insert the hose ring. Secure the hose ring with the locking pin. Proceed to slide the opposite end of the 6" hose onto the outlet of the blower assembly. See (Figure 2-23) for details. Make sure both ends of the hose are clearly attached to the inlet and the blower assembly inlet. Tighten the hose clamps.

## 2-22 Lower Hose To Blower Cone Installation

Slide a 8" hose clamp P#(J0080) over both ends of the lower hose. Then proceed to slide the lower hose onto the blower cone. Tighten the hose clamp. The assembly should look like Figure 2-23.

## 2-23 Lower Hose To Boot Installation

Take the unattached end of the lower hose and slide it over the circular end of the boot. Use the lower hose clamp to secure the hose to the boot (Figure 2-23). Tip: Before securing clamp rotate hose counter-clockwise (away from yourself) approximately 1" to aid in retaining boot to mower deck.

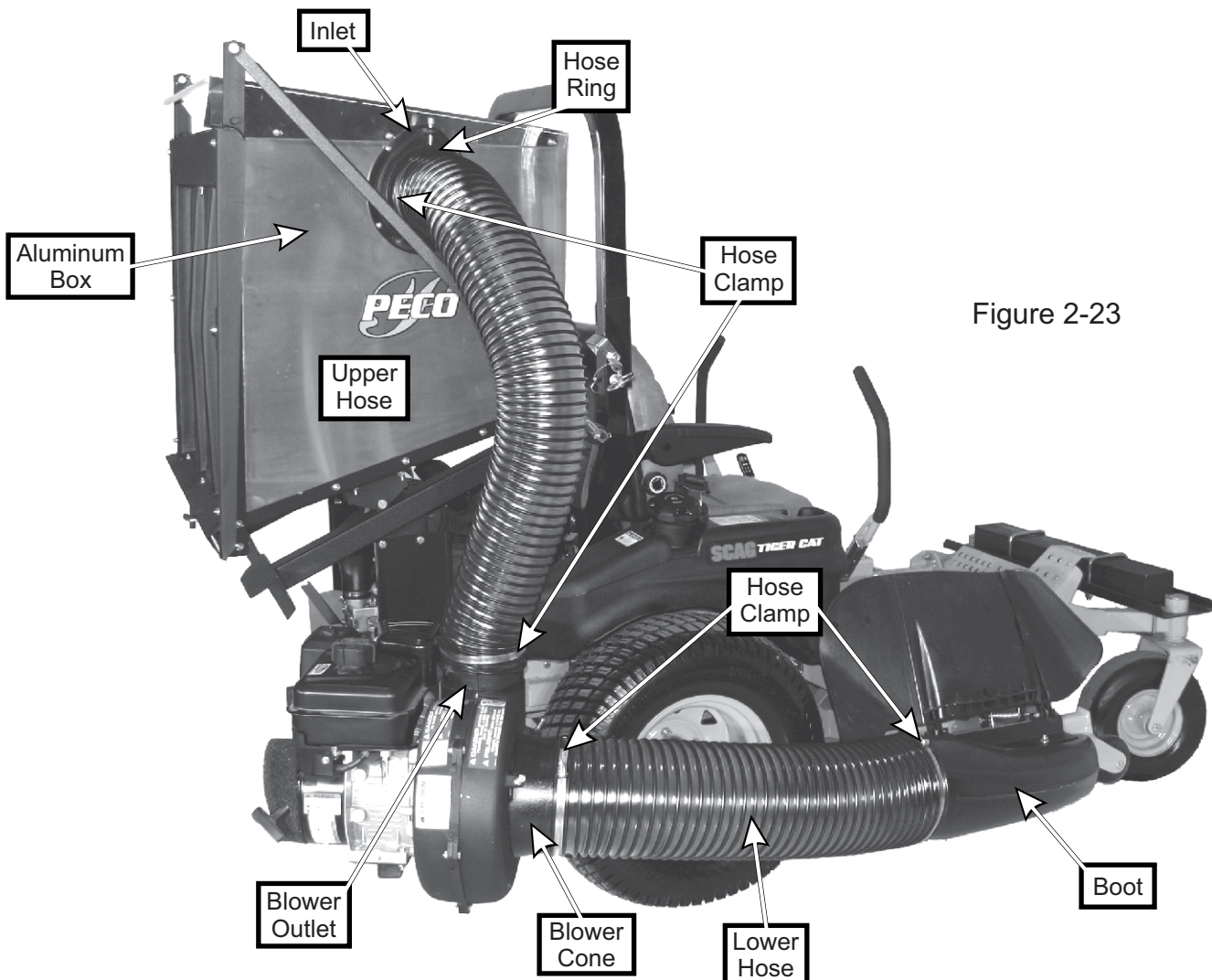

Figure 2-23

## 2-24 Impeller Blade Removal/Replacement

To gain impeller blade (#1) access, first remove the blower cone (#2) from the blower housing, located on the PTO assembly P#(A1821), by removing two blower cone bolts and nuts (#3). Next, remove the blower housing front (#4) by removing seven bolts and nuts (#5) around the outer housing edge. Refer to Figure 2-24.

**To Remove:** First, remove one 3/8"-16 x 1-1/2" HHCS P#(K1211) (#6), one taper-lock bushing washer P#(K0278) (#7) and one spacer bushing P#(S3242) (#8) from the taper-lock bushing (#9). See Figure 2-24. Next, remove two 1/4"-20 x 1" HHCS (#10) and place them into the threaded holes (#11) of the taper-lock bushing P#(S4302). Last, gradually thread each bolt evenly into the taper-lock bushing, forcing the blade to break-away from the taper-lock bushing.

### Tips on removing impeller blade;

- 1 - Try carefully hitting the base of the impeller blade (#1), between each vein (#12), with a rubber mallet to loosen the taper-lock bushing hold.
- 2 - Spray break-free lubricant into the surrounding areas of the taper-lock bushing (#9) and repeat Tip 1.

**To Replace:** First, place the impeller blade (#1) over the drive shaft (#13). Next, slide the taper-lock bushing (#9) on to the drive shaft and into the impeller blade, aligning the **non-threaded** holes (#14) of the taper-lock bushing to the threaded holes of the impeller blade. Then, fasten by using two 1/4"-20 x 1" HHCS (#10), one spacer bushing (#8) one taper lock bushing washer (#7), and one 3/8"-16 x 1-1/2" HHCS (#6). Torque all bolts to the specifications located in the chart towards the back of this manual. Last, rotate the impeller blade to ensure that the blade is clear of contact on all sides of the blower housing.

Figure 2-24

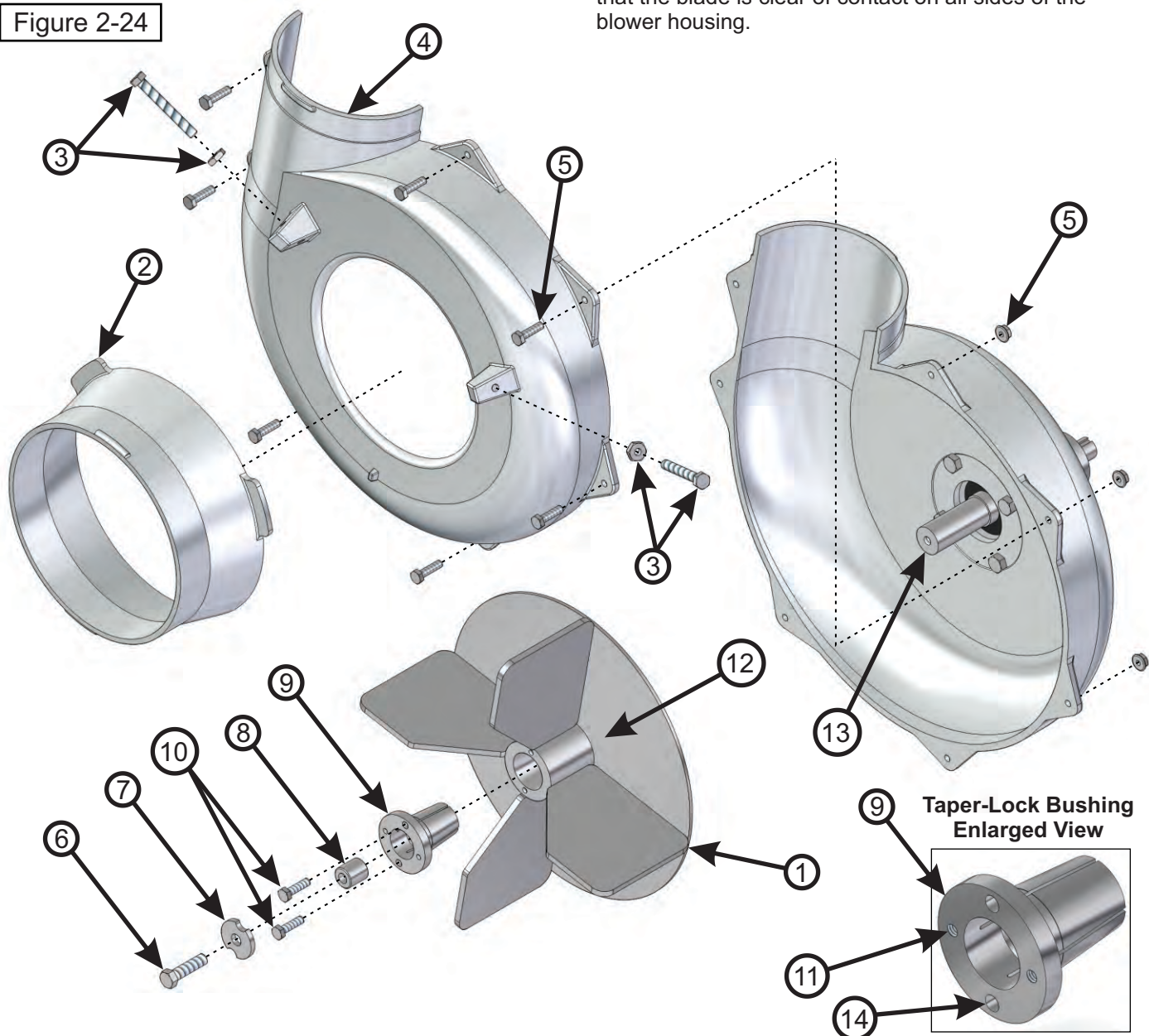



## 2-25 Weight Kit Installation

The collection system requires that a weight kit is installed to the front of the mower to counter-balance the weight of the collection system, when filled with debris.

**NOTE:** The (2) weight brackets are secured to the caster supports first. Then the weight is added to the weight brackets. It is recommended that two people perform this procedure. If another person is not available, use a rolling hydraulic floor jack to keep the weight into position while you secure the weight to the weight brackets

Locate the (2) weight brackets P#(B0026). Secure (1) bracket to each front caster support, using (1) 3/8"-16 x 2-1/8" u-bolt P#(K1119) and (2) 3/8"-16 nylon flange lock nuts P#(K2038) **PER BRACKET**. Position the weight bracket as shown in Figure 2-25a. Insert the u-bolt from the bottom of the caster support tube as shown in Figure 2-25b. Leave the hardware slightly loose until the weight has been installed.

After the weight brackets have been secured to the caster supports, place (1) weight bar P#(B0035) onto the (2) weight brackets. It is strongly recommended that someone assist you in lifting the weight bar into position. Center the weight bar between the front casters. Secure the weight bar to the weight bracket using (2) 1/2"-13 x 4-5/16" u-bolts P#(K0331) and (4) 1/2"-13 nylon flange lock nuts P#(K2012). Tighten the weight bracket hardware at this time. Refer to Figure 2-25c and 2-25d for reference.

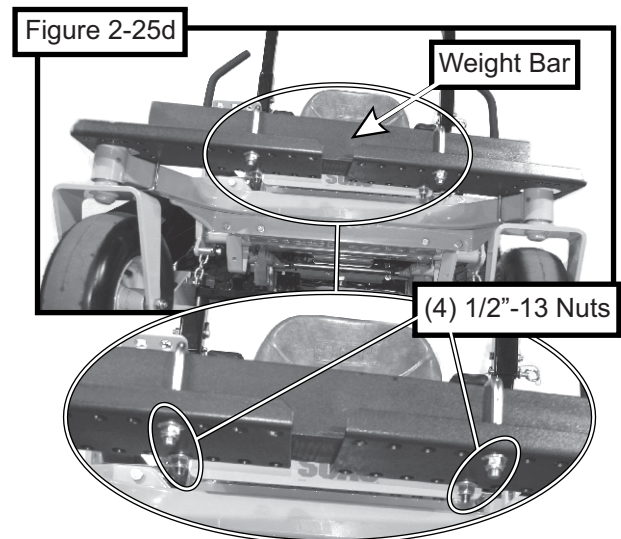
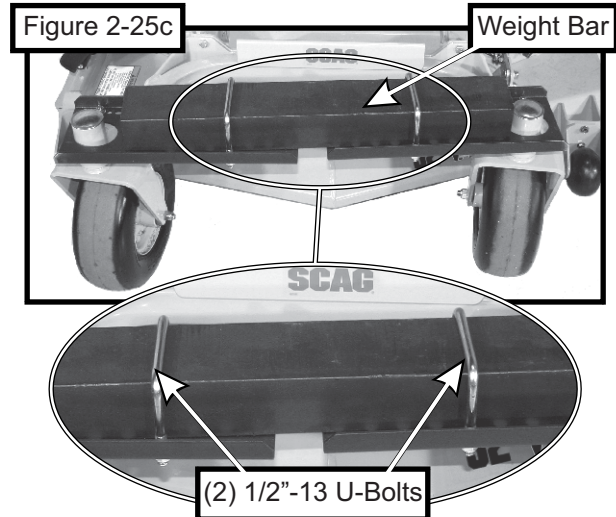
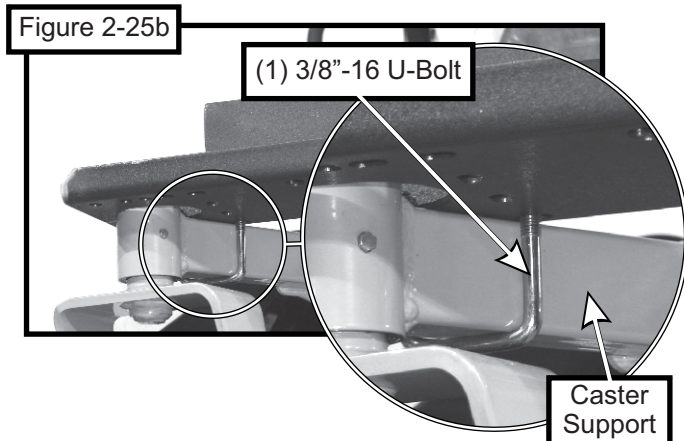
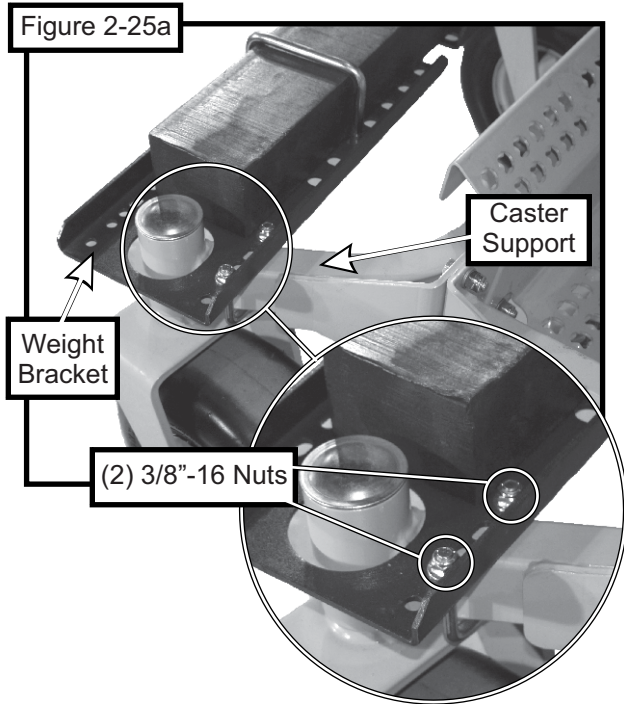

## 2-26 Throttle Cable Installation

### NOTE: Engine Driven Models Only

To install the throttle cable kit to the ROPS (roll over protection system), place the 3/8" U-Bolt P#(K0136) onto the ROPS with the threads facing the front of the mower. Next slide on the throttle mount plate assembly P#(A0666) with the rivets also facing toward the front of the mower. Tighten the throttle mount plate assembly securely to the ROPS using (2) 3/8"16 nylon flange lock nuts P#(K2038) (Figure 2-26a). With the throttle cable facing toward the engine/blower/blade assembly, place the throttle base plate over the rivets. Slide the throttle cable kit to the right, moving the smaller end of the slot over the rivets. When positioned correctly, the throttle spring plate will snap into place (Figure 2-26b).

To remove the throttle cable kit, lift the throttle spring plate and slide the throttle kit to the left.

Route cable over the upper hose as shown in Figure 2-26c.

Figure 2-26a

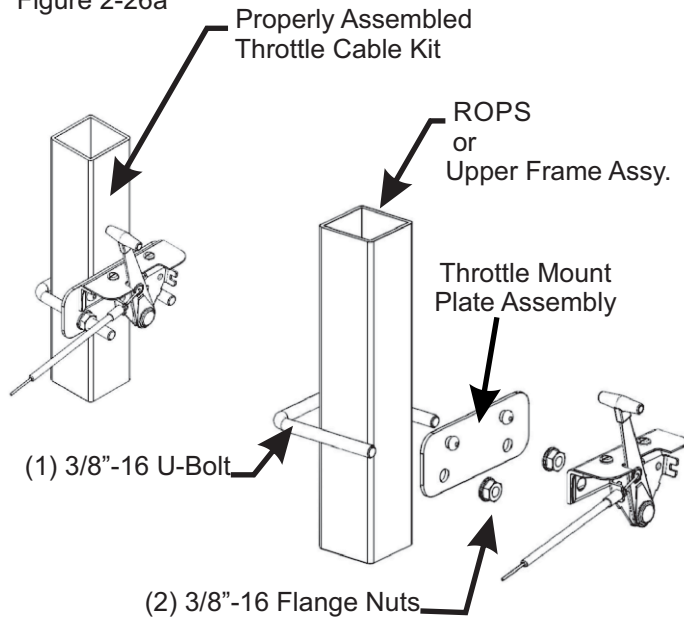

Figure 2-26b

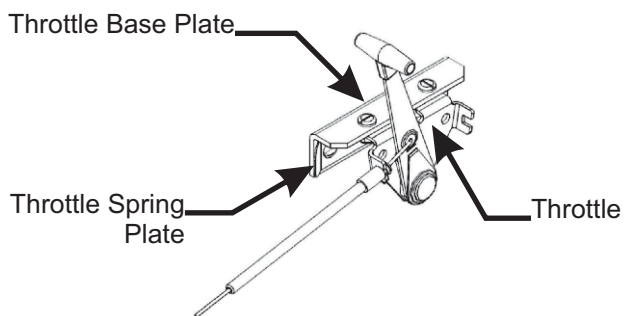
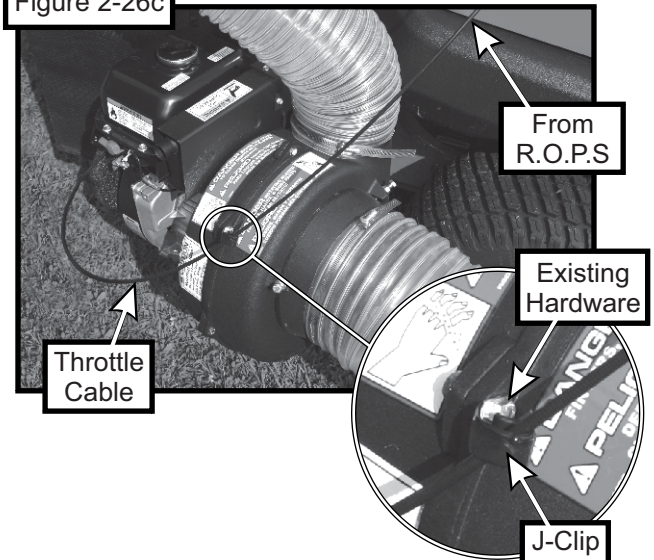

Figure 2-26c



Secure the throttle cable to the blower housing assembly using (1) J-Clip P#(K1455). Use the existing hardware from the blower housing to secure the J-Clip, as shown in Figure 2-26c.

To fasten the throttle cable end to the engine, place the throttle control lever into the "stop" position. Rotate the engine throttle lever to the "stop" position. Thread the wire end of the throttle cable into the engine throttle lever eyelet and tighten the screw. Fasten the throttle cable sleeve to the clamp on the engine throttle (Figure 2-26d). Rotate the throttle control lever into the "fast" position to check for proper installation.

**NOTE:** Cable sleeve may need to be cut, depending on the engine type. Once throttle cable is attached, lift the plastic top assembly and make sure that the throttle cable does not interfere with the movement of the plastic top.

Figure 2-26d

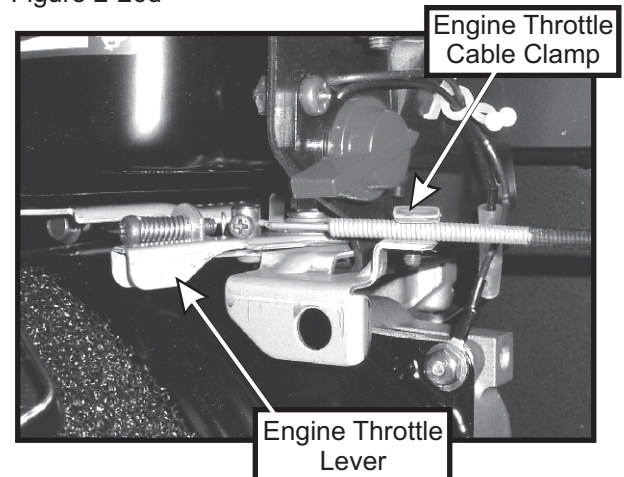

A0794  
 ALUMINUM GRASS  
 CONTAINER  
 EXPLODED VIEW

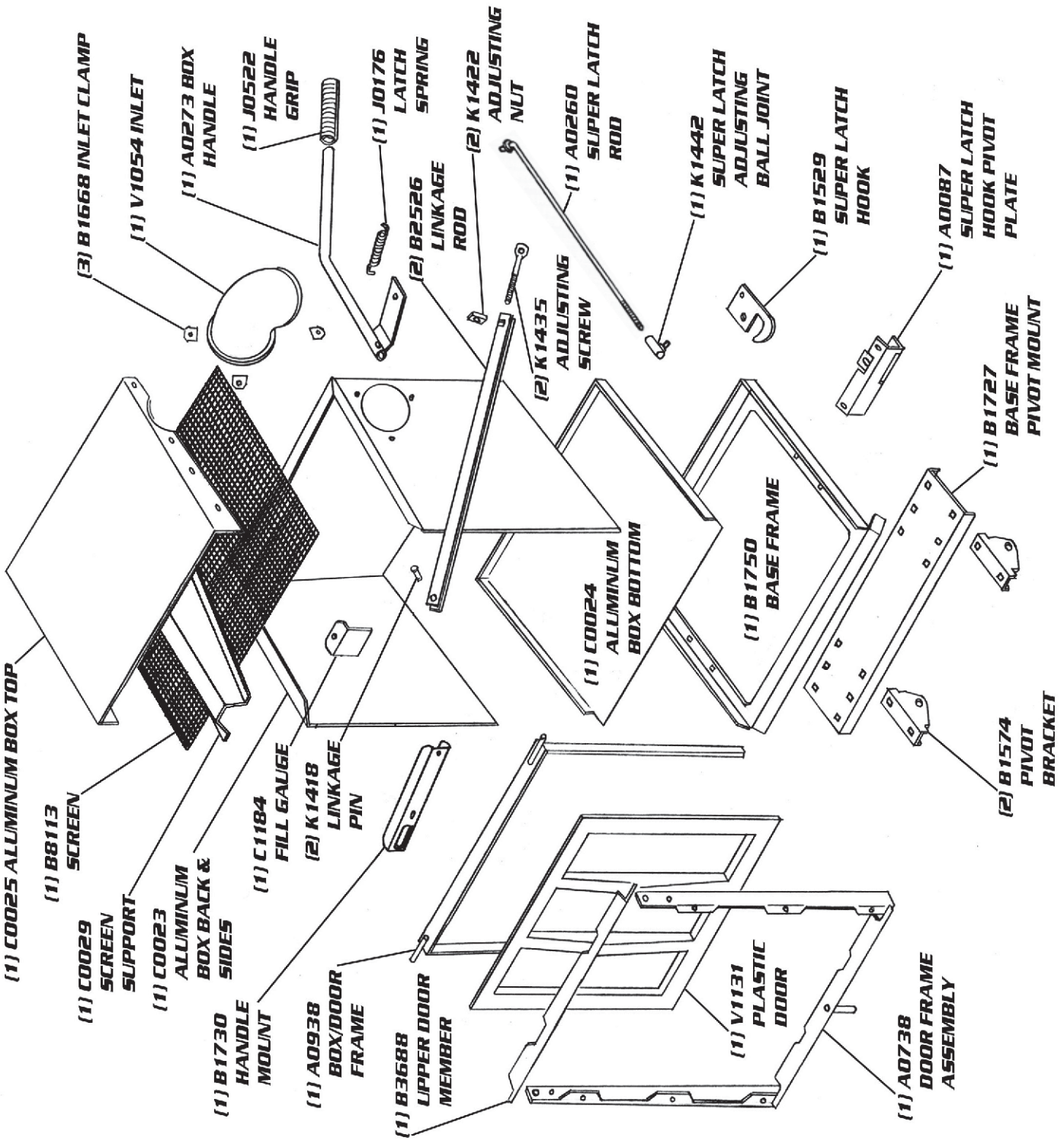

# **Exploded Parts View**

## **A0623 PTO Assembly**

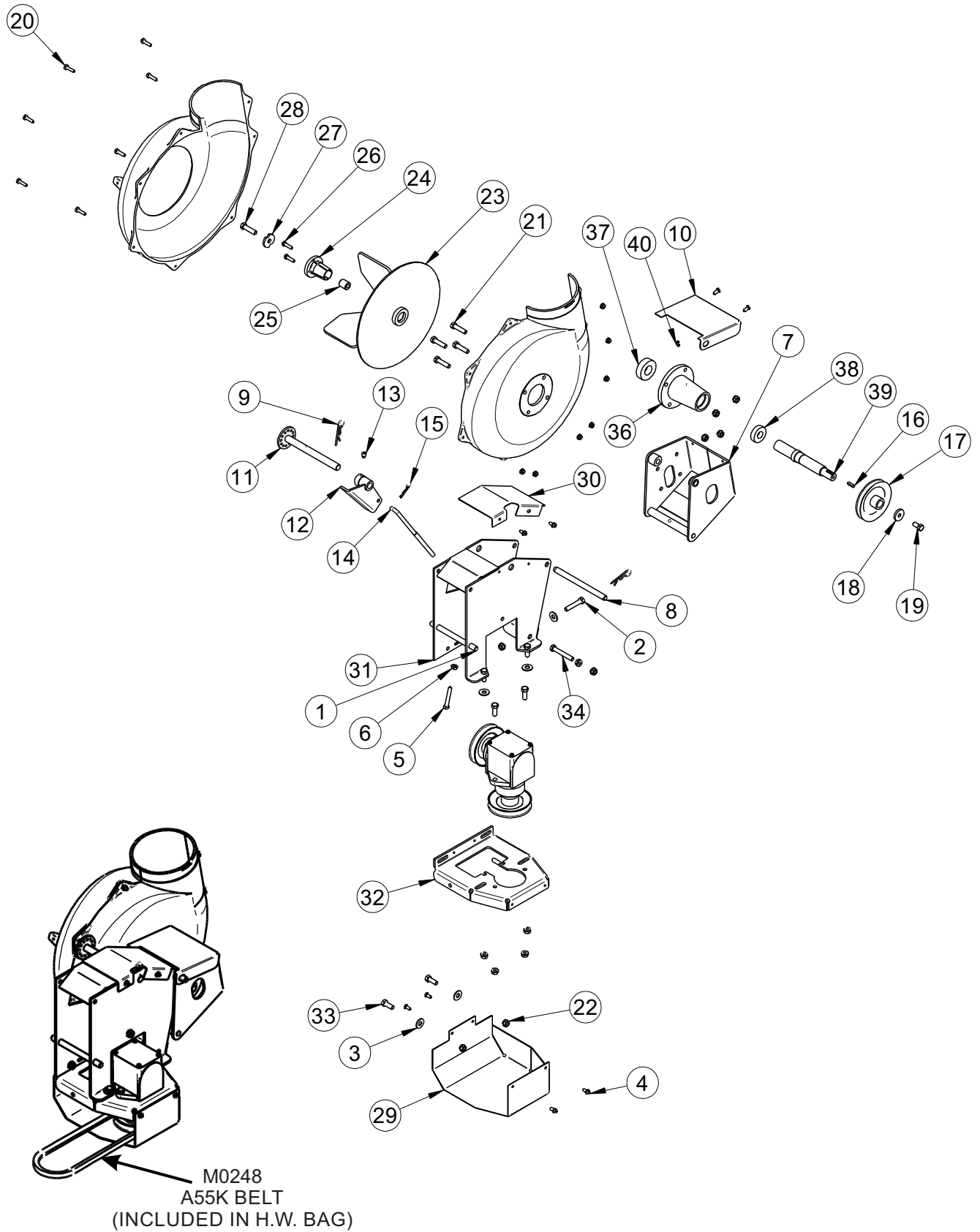

# **PTO Parts List**

## **A0623 PTO Assembly**

Item Number	Document Number	Title	Quantity
1	A0429	GEAR BOX ASSEMBLY	1
2	K0348	3/8"-16 x 2" ALL THREAD HHCS	1
3	K0047	3/8" FLAT WASHER 1.00 OD x .446 ID x .075 T	5
4	K0353	1/4"-20 x 1/2" HHSTS	8
5	K1159	5/16"-18 x 2" ALL THREAD HHCS	1
6	K1178	5/16"-18 FLANGE NUT	1
7	A0144	BLOWER MOUNT BRACKET ASSEMBLY	1
8	B1755	BLOWER PIVOT ROD	1
9	K0086	.125 OD x 2.50 HAIR PIN CLIP	2
10	B0121	BLOWER BELT GUARD	1
11	A0604	PTO HANDLE MOUNT ASSY	1
12	A0422	CAM BRACKET ASSEMBLY	1
13	K0356	3/8"-16 TAPERED SET SCREW	1
14	K0326	BELT TENSION ROD 3/8"-16	1
15	K0130	.091 OD x 1.625 L HAIR PIN CLIP	1
16	J0254	3/16" SQ. x 3/4" LONG KEYWAY	1
17	M0228	BLOWER PULLEY	1
18	K1446	1.187 OD x .380 ID x .187 WASHER	1
19	K1190	3/8"-16 x 3/4" HHCS	1
20	E4004A	BLOWER HSG. ASSY.	1
21	K1193	3/8"-16 x 1-1/2" HHCS	4
22	K1215	3/8"-16 FLANGE NUT	12
23	A0645	SMALL 4-BLADE IMPELLER	1
24	S4302	TAPER-LOCK BUSHING	1
25	S3242	PLATED BUSHING	1
26	K1225	1/4"-20 X 1" HHCS GRADE 8	2
27	K0278	TAPER-LOCK BUSHING WASHER	1
28	K1211	3/8"-16 x 1-1/2" HHCS GRADE 8	1
29	B0269	GEAR BOX PULLEY GUARD	1
30	B0270	PTO ARM GUARD	1
31	A0622	PTO ARM ASSY.	1
32	A0624	BASE PLATE ASSY.	1
33	K1191	3/8"-16 x 1" HHCS	6
34	K1197	3/8"-16 X 2 1/2" HHCS	1
35*	M0250	A30K KEVLAR BELT	1
36	E0121	PTO SHAFT HOUSING	1
37	N0147	BEARING 2.0472 OD, 0.9843 ID, 0.5906 W (6205RS PEER)	1
38	N0148	BEARING 1.625 OD, 0.75 ID, 0.4375 W (9R12 PEER)	1
39	B1758	PTO SHAFT	1
40	J0801	1/4"-28 ZIRC FITTING	1

# Unit Model #: 37621231

Mower: Scag

Owner's Manual: Q0438

Mower Type: Freedom Z

Engine Type: Kawasaki FS730V

Deck Size: 61" Commercial

Vac Type: 12 Cu. Ft. Pro 12 DFS

Deck Type:

Drive Type: PTO Drive

Revision #: Updated To Fit 2014 Mowers 9/9/2014

Fits Year(s): 2012-2014

## A1853 Vac Kit

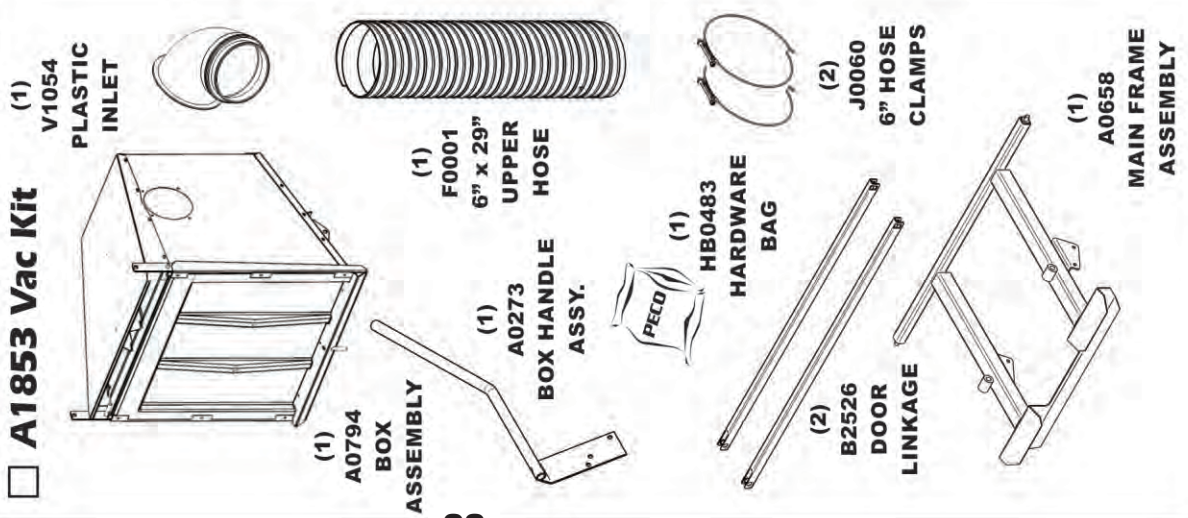

## A1155 61" BAFFLE KIT

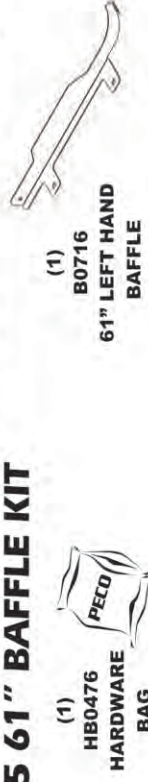

## A1854 Mount Kit

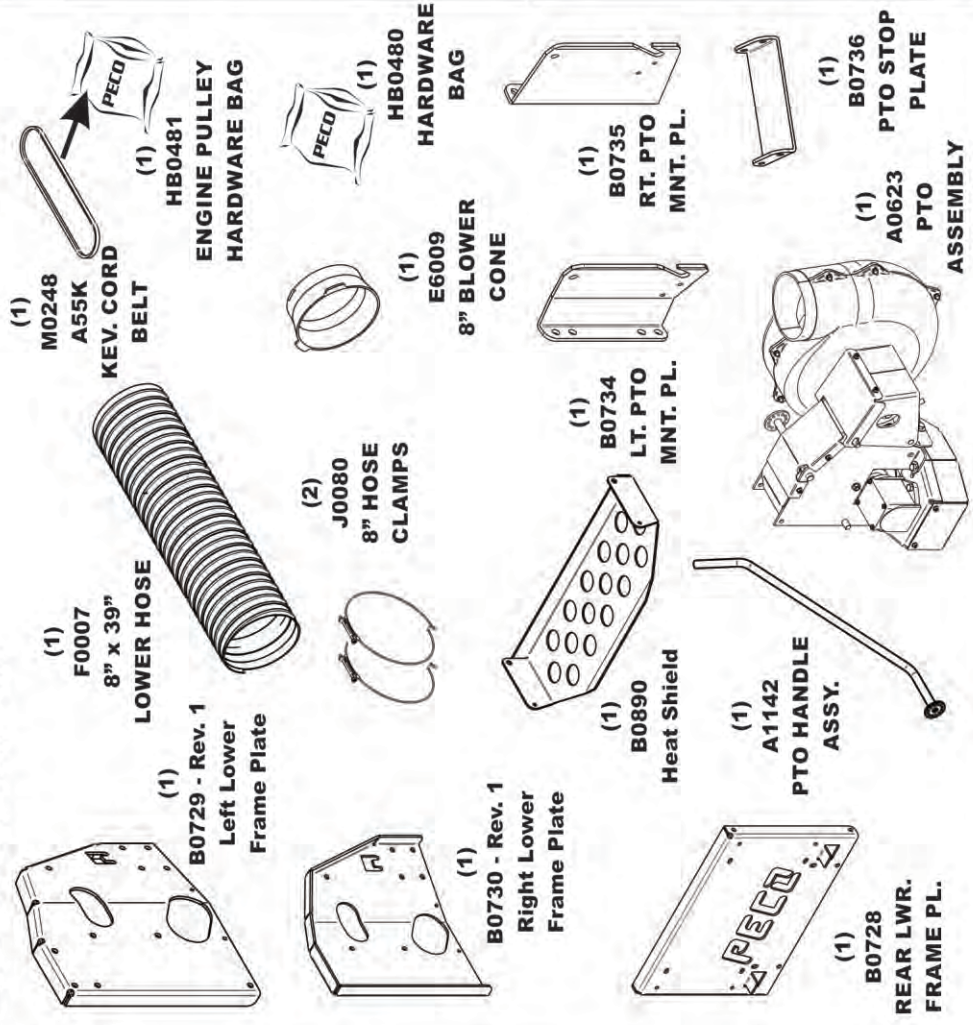

## A1857 Boot Kit

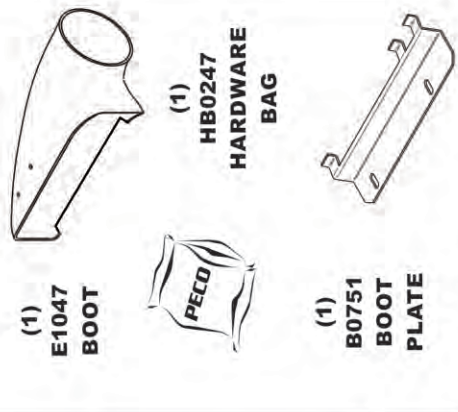

## A0683 Weight Kit

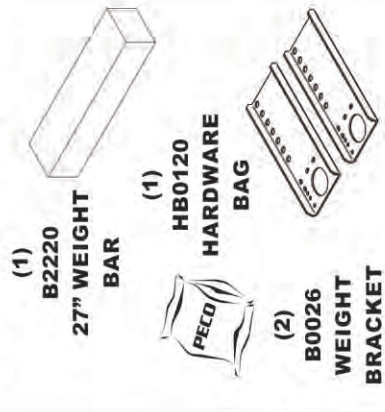

# Unit Model #: 37621232

Mower: Scag

Owner's Manual: Q0438

Mower Type: Freedom Z

Engine Type: Kawasaki FS730V

Deck Size: 61" Commercial

Vac Type: 12 Cu. Ft. Pro 12 DFS

Deck Type:

Drive Type: Briggs & Stratton 900 Series

Revision #: Updated To Fit 2014 Mowers 9/9/2014

Fits Year(s): 2012-2014

## A1853 Vac Kit

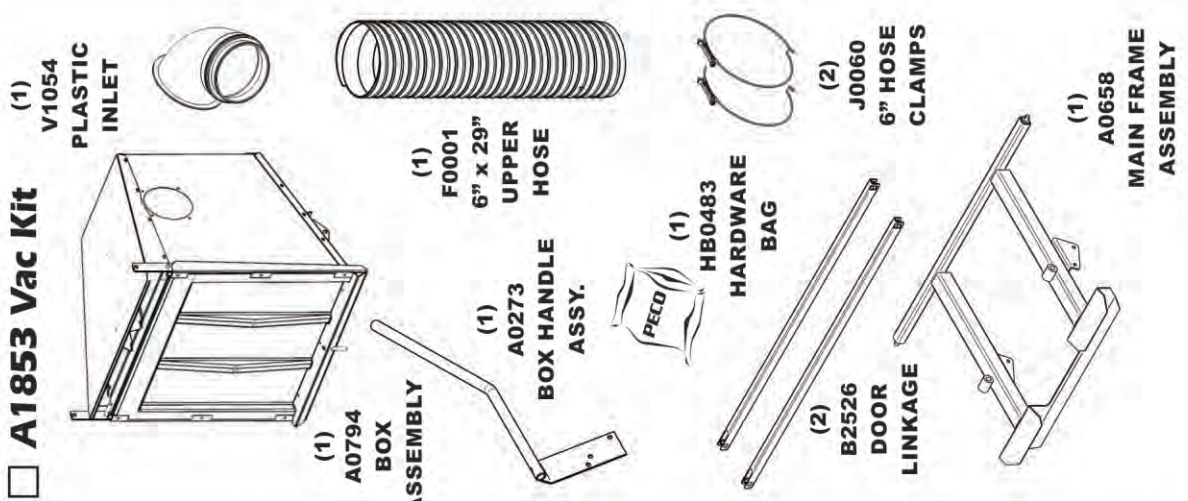

## A1155 61" Baffle Kit



## A1855 Mount Kit

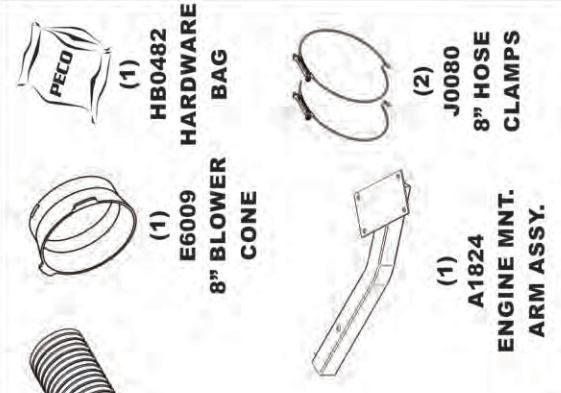
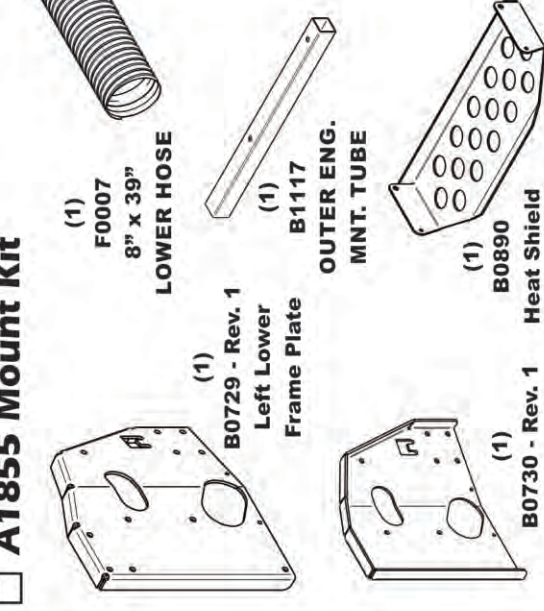

## A1857 Boot Kit

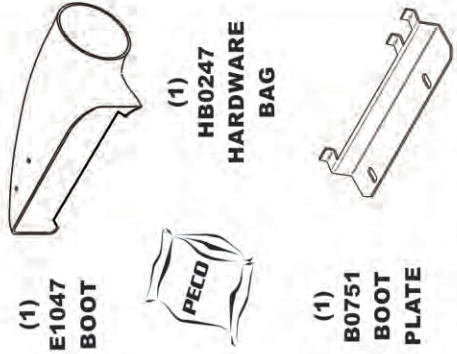

## A0619 Throttle Kit

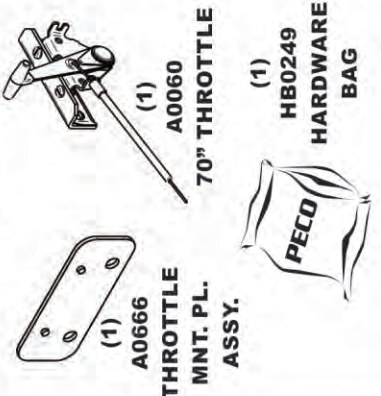

## A0683 Weight Kit

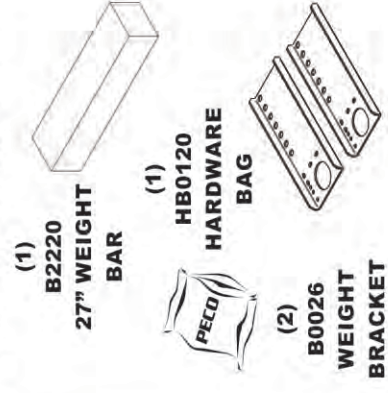

# Unit Model #: 37621233

Mower: Scag

Owner's Manual: Q0438

Mower Type: Freedom Z

Engine Type: Kawasaki FS730V

Deck Size: 61" Commercial

Vac Type: 12 Cu. Ft. Pro 12 DFS

Deck Type:

Drive Type: Briggs & Stratton 6.5HP Vanguard

Revision #: Updated To Fit 2014 Mowers 9/9/2014

Fits Year(s): 2012-2014

## A1853 Vac Kit

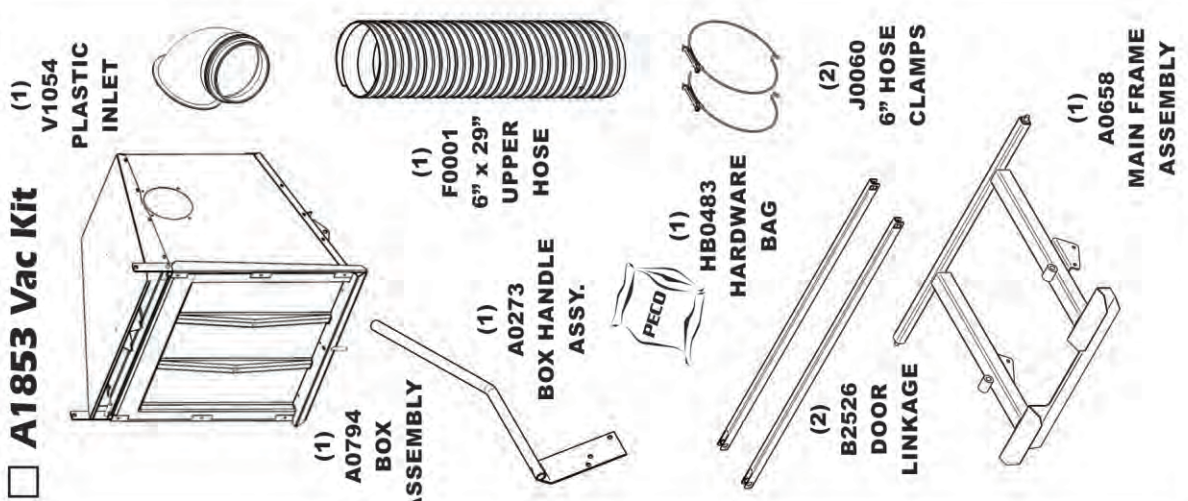

## A1155 61" Baffle Kit



## A1856 Mount Kit

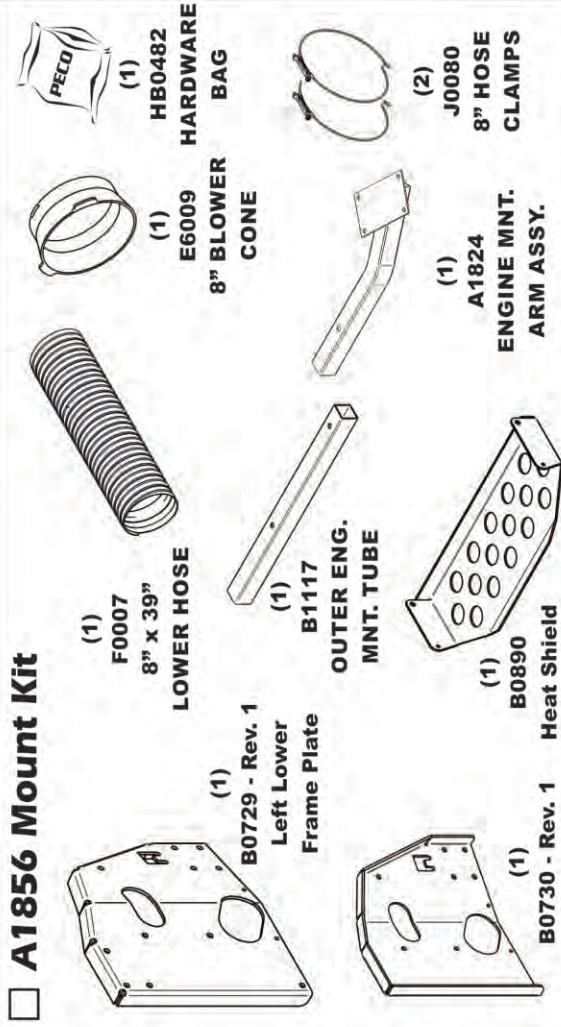

## A1857 Boot Kit

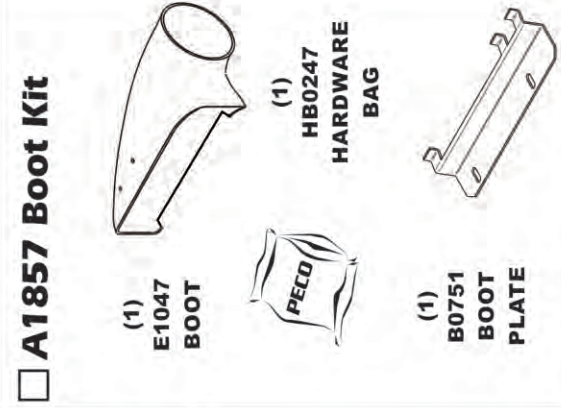
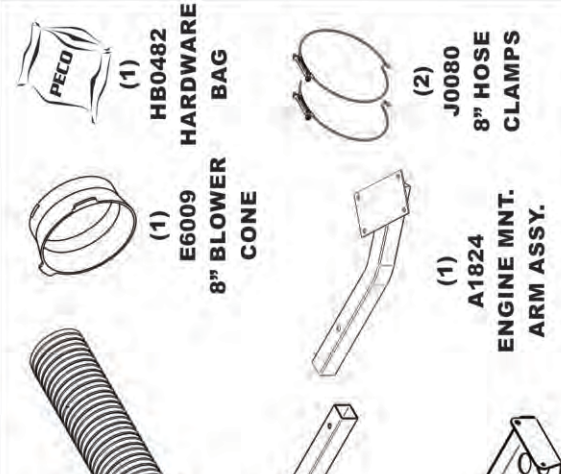

## A0619 Throttle Kit

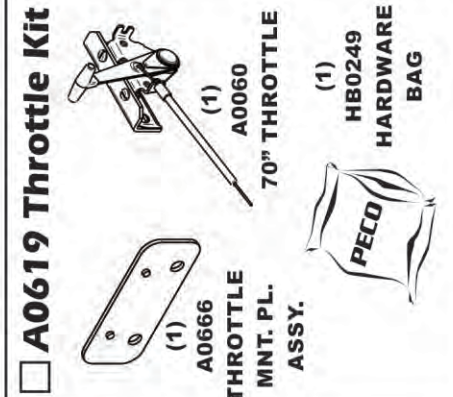

## A0683 Weight Kit

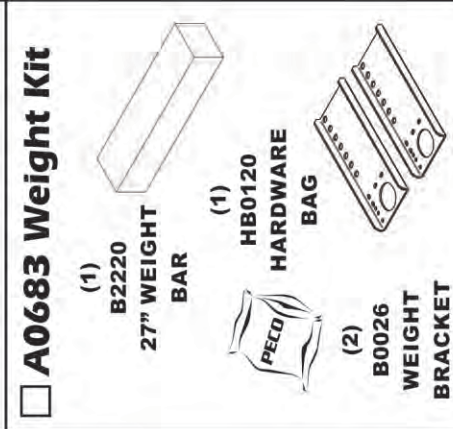



## SECTION III

### OPERATING INSTRUCTIONS

#### 3-1 General Safety

Only qualified people familiar with this operator's manual and the mower's operator's manual should operate this machine.

#### 3-2 Operation And Tips On Mowing

##### PTO MODELS

- A. Perform BEFORE EACH USE the maintenance list in paragraph 4-1.
- B. Start mower.
- C. With the mower at high idle speed, engage the mower deck.
- D. While seated in the operator's seat, rotate the engagement handle of the collection system away from the mower. Continue to rotate the handle until it stops in an over center position. With the blower engaged, you can proceed to operate the control levers of the mower.

##### ENGINE DRIVEN MODELS

- A. Perform BEFORE EACH USE maintenance list in paragraph 4-1.
- B. Start the engine/blower/blade assembly.
- B. Start mower.
- C. With the mower at high idle speed, engage the mower deck.
- D. Proceed to operate the control levers of the mower.

**NOTE:** If the collection system does not appear to be collecting the grass clippings; disengage the deck, and blower, engage the parking brake and turn the mower off. Check the upper hose, lower hose, top screen and boot for clogs.

To obtain the maximum effectiveness from your collection system the tips listed below should be followed:

- \* Watch your speed- Normal conditions will allow a speed of up to approximately 5 mph, but thick, heavy damp conditions will require reduced ground speed.
- \* Mow with sharp blades- A sharp blade cuts cleaner.
- \* Wet grass and leaves will decrease effectiveness and will increase horsepower requirements.
- \* Mow at higher cutting heights- Remove and mulch no more than 2" of grass length with each mowing. (Experts recommend not cutting off more than 1/3 of the grass blade length at any given time.)
- \* Mow twice, at different height settings, (high, then low), if grass is extra tall.
- \* Remember that horsepower requirements will vary with the mowing conditions such as type and height of turf grass, moisture content, amount of leaves, whether the terrain is flat or hilly, etc.

#### 3-3 Disengagement Of The Blower

##### PTO MODELS

- A. To disengage the blower, rotate the engagement handle towards the mower.

**WARNING:** The blower will continue to spin. DO NOT TOUCH the blower, pulleys, or the belt until the tractor is turned off. DO NOT adjust the belt tension until the mower is turned off. Refer to section 2-10 of the manual.

##### ENGINE DRIVEN MODELS

- B. (5.5HP Briggs & Stratton) To stop the engine, throttle the engine to the stop position.
- C. (6.5HP Briggs & Stratton Vanguard) To stop the engine, move the fuel lever to the OFF position.

#### 3-4 Unloading The Collection System

**NOTE:** Press the tab, located behind the operator's left side, downward to feel if the collection system is full. If the container is full there will be resistance when depressing the tab.

- A. Stop the forward movement of the mower.
- B. Disengage the mower deck.
- C. Disengage the blower or turn the external engine off.
- D. Verify that the dump area is clear.
- E. Push the dump handle, on the left of the operator, away from the unit. While holding the handle pushed away, move the handle upward. The container door will swing upward and the container will rotate downward. The container will release its contents.
- F. Once the contents of the container have fallen out, the container is ready to move back into its normal operating position. With the handle in the 'away' position, pull the handle downward until it stops. Move the handle towards the center of the mower. This motion will allow the latch to lock back into collection position.

**NOTE:** If you do not hold the handle away from the mower as you pull the handle downward, the latch will not lock and the container can unexpectedly release the contents collected.

## SECTION IV

### MAINTENANCE

#### 4-1 Maintenance Checklist

Before each use:

1. Check blades and spindles to be sure that no foreign objects, such as wire or steel strapping bands, are wrapped around them.
2. Inspect blades for wear. Replace if necessary. If it is necessary to sharpen the blades, remove the blades from the spindles before sharpening. DO NOT sharpen blades while still attached to the mower.

3. Make sure all shields are in place and in good condition. Repair or replace any missing or damaged shields.
4. Perform lubrication per paragraph 4-2.
5. Listen for abnormal sounds, which might indicate loose parts, damaged bearings, or other damage. Correct any deficiency before continuing operation.
6. **PTO MODELS ONLY:** With the engine off, engage the blower assembly. Check the belt tension and inspect the pulley belt for cracks or tears.
7. Check for wear or deterioration of the upper or lower hoses. If there are any portions of the hose that have been torn or worn through, replace with genuine PECO parts.

After Each Use:

1. Clean all debris from machine especially from the container, underneath the belt shields, and safety decals. Replace any missing or illegible decals.
2. Inspect the unit for worn or damaged components. Repair or replace before the next use. Any replacement component installed during repair shall include the component's current safety decal specified by the manufacturers to be affixed to the component.
3. **PTO MODELS ONLY:** Check belt for proper tension.

THE SERIAL NUMBER PLATE IS LOCATED ON THE BOX ASSEMBLY P#(A0560)

<b>PECO</b>	
<b>OUTDOOR POWER EQUIPMENT</b>	
<b>Model Number</b>	<input style="width: 90%;" type="text"/>
<b>Serial Number</b>	<input style="width: 90%;" type="text"/>
<b>Arden, North Carolina 28704</b>	

WRITE THE MODEL AND SERIAL NUMBER IN THE BOX ABOVE FOR FUTURE REFERENCE.

## 4-2 Lubrication For PTO Models

**NOTE:** Use only white lithium based grease for lubrication of the shaft on the blower assembly.

1. On initial use: Grease the fitting on the blower shaft.
2. Every 25 hours of use: Re-grease the grease fitting.
3. Every 200 hours of use: Check oil levels in gear box. Oil in gear box should cover the gears. If necessary, fill using an EP90 weight oil. 6oz. will fill the gear box from empty.

# SECTION V PARTS AND SERVICE

## 5-1 Parts And Service Information

PECO collection system owners should record the name and telephone number of their Service Center. Your Service Center will be happy to supply replacement parts, accessories, and do any service or repairs to your collection system. If for any reason your Service Center is unable to service your collection system or supply replacement parts, contact PECO and include the following information on the chart below.

**Unit Model Number:** \_\_\_\_\_  
**Unit Engine Size:** \_\_\_\_\_  
**Unit Serial Number:** \_\_\_\_\_  
**Date of purchase:** \_\_\_\_/\_\_\_\_/\_\_\_\_\_  
**Dealer/Distributor Name:** \_\_\_\_\_  
**Dealer's/Distributor's:** \_\_\_\_\_ **State:** \_\_\_\_\_ **Zip:** \_\_\_\_\_  
**Phone Number:** \_\_\_\_\_

**Address: PECO Inc.**  
**10 Walden Drive**  
**Arden, NC 28704**  
**Phone #: (828) 684-1234 or Toll Free: (800) 438-5823**  
**Email: peco@lawnvac.com**

# SAFETY DECALS

To promote safe operation, PECO supplies safety decals on all products manufactured. Damage can occur to safety decals either through shipment, use or reconditioning. Contact your local Service Center for replacement decals.

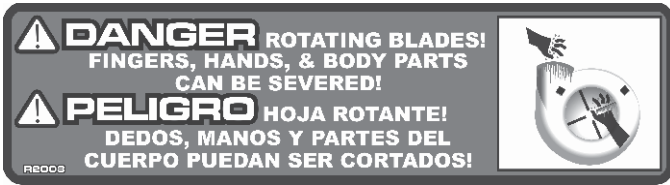

# R2008



# R2007

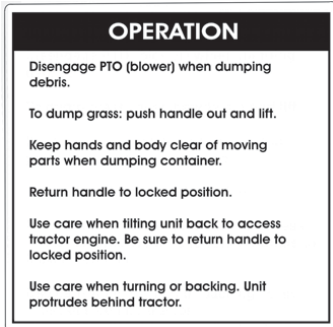

Part #: R1049



Part #: R1069



Part #: R1053



Part #: R1057



Part #: R1055



Part #: R1054



Part #: R4015



Part #: R4037



Part #: R4027



Part #: R1052

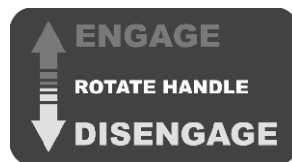

Part #: R1083



Part #: R1065



Part #: R4008



Part #: R1051



Part #: R1070

# TORQUE SPECIFICATIONS

Proper torque for American fasteners used on Peco equipment.  
Recommended Torque in Foot Pounds (Newton Meters).\*

## AMERICAN Bolt Head Markings

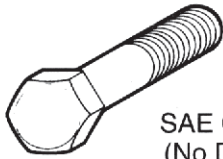

SAE Grade 2  
(No Dashes)

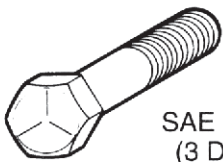

SAE Grade 5  
(3 Dashes)

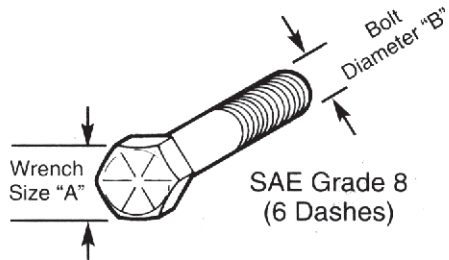

SAE Grade 8  
(6 Dashes)

WRENCH SIZE (IN.) "A"	BOLT DIAMETER (IN.) "B" AND THREAD SIZE	SAE GRADE 2	SAE GRADE 5	SAE GRADE 8
7/16	1/4 - 20 UNC	6 (7)	8 (11)	12 (16)
7/16	1/4 - 28 UNF	6 (8)	10 (13)	14 (18)
1/2	5/16 - 18 UNC	11 (15)	17 (23)	25 (33)
1/2	5/16 - 24 UNF	13 (17)	19 (26)	27 (37)
9/16	3/8 - 16 UNC	20 (27)	31 (42)	44 (60)
9/16	3/8 - 24 UNF	23 (31)	35 (47)	49 (66)
5/8	7/16 - 14 UNC	32 (43)	49 (66)	70 (95)
5/8	7/16 - 20 UNF	36 (49)	55 (75)	78 (106)
3/4	1/2 - 13 UNC	49 (66)	76 (103)	106 (144)
3/4	1/2 - 20 UNF	55 (75)	85 (115)	120 (163)
7/8	9/16 - 12 UNC	70 (95)	109 (148)	153 (207)
7/8	9/16 - 18 UNF	79 (107)	122 (165)	172 (233)
15/16	5/8 - 11 UNC	97 (131)	150 (203)	212 (287)
15/16	5/8 - 18 UNF	110 (149)	170 (230)	240 (325)
1-1/8	3/4 - 10 UNC	144 (195)	266 (360)	376 (509)
1-1/8	3/4 - 16 UNF	192 (260)	297 (402)	420 (569)
1-5/16	7/8 - 9 UNC	166 (225)	430 (583)	606 (821)
1-5/16	7/8 - 14 UNF	184 (249)	474 (642)	668 (905)
1-1/2	1 - 8 UNC	250 (339)	644 (873)	909 (1232)
1-1/2	1 - 12 UNF	274 (371)	705 (955)	995 (1348)
1-1/2	1 - 14 UNF	280 (379)	721 (977)	1019 (1381)
1-11/16	1-1/8 - 7 UNC	354 (480)	795 (1077)	1288(1745)
1-11/16	1-1/8 - 12 UNF	397 (538)	890 (1206)	1444 (1957)
1-7/8	1-1/4 - 7 UNC	500 (678)	1120 (1518)	1817 (2462)
1-7/8	1-1/4 - 12 UNF	553 (749)	1241 (1682)	2013 (2728)
2-1/16	1-3/8 - 6 UNC	655 (887)	1470 (1992)	2382 (3228)
2-1/16	1-3/8 - 12 UNF	746 (1011)	1672 (2266)	2712 (3675)
2-1/4	1-1/2 - 6 UNC	870 (1179)	1950 (2642)	3161 (4283)
2-1/4	1-1/2 - 12 UNF	979 (1327)	2194 (2973)	3557 (4820)

## METRIC

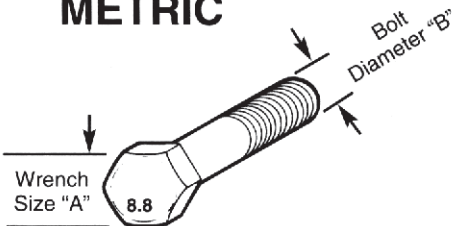

Numbers appearing on bolt heads indicate ASTM class.

Proper torque for metric fasteners used on Peco equipment.  
Recommended torque in foot pounds (newton Meters).\*

WRENCH SIZE (mm) "A"	BOLT DIA. (mm) "B"	ASTM 4.6	ASTM 8.8	ASTM 9.8	ASTM 10.9
8	5	1.8 (2.4)		5.1 (6.9)	6.5 (8.8)
10	6	3 (4)		8.7 (12)	11.1 (15)
13	8	7.3 (10)		21.1 (29)	27 (37)
16	10	14.5 (20)		42 (57)	53 (72)
18	12	25 (34)	74 (100)	73 (99)	93 (126)
21	14	40 (54)	118 (160)	116 (157)	148 (201)
24	16	62 (84)	167 (226)	181 (245)	230 (312)
30	20	122 (165)	325 (440)		449 (608)
33	22		443 (600)		611 (828)
36	24	211 (286)	563 (763)		778 (1054)
41	27		821 (1112)		1138 (1542)
46	30	418 (566)	1119 (1516)		1547 (2096)

\*Use 75% of the specified torque value for plated fasteners. Use 85% of the specified torque values for lubricated fasteners.



**10 WALDEN DRIVE  
ARDEN, NORTH CAROLINA 28704  
(800) 438-5823 OR (828) 684-1234 FAX: (828) 684-0858  
EMAIL: [peco@lawnvac.com](mailto:peco@lawnvac.com)  
WEBSITE: [www.lawnvac.com](http://www.lawnvac.com)**