



ENGINE DRIVEN - GRASS COLLECTION SYSTEM

Model# 06742408 & 06742410

John Deere
TerrainCut

MODEL YEAR:
2015-NEWER
60" & 72" DECKS



Fits Model: 1550, 1570, 1575

OPERATOR'S MANUAL

ASSEMBLY • OPERATION • MAINTENANCE

GRASS COLLECTION SYSTEM

TABLE OF CONTENTS

SECTION	PAGE	SECTION	PAGE
Safety	2	Length of Hose Adjustment	20
Safety Alert Symbols	3	Upper Hose Installation	20
Warranty	4	Lower Hose To Blower Cone Installation	20
I INTRODUCTION AND DESCRIPTION	5	Lower Hose To Boot Installation	20
Introduction	5	Impeller Blade Removal / Replacement	21
Description	5	Exploded Views	22-25
II INSTALLATION FOR USE	6	Overall Parts Lists	26-27
Preparation Of Mower	6	Safety Decals	28
Battery Cover Preparation	6	III OPERATING INSTRUCTIONS	29
Rear Main Frame Installation	6-7	General Safety	29
Box Support Frame Assembly	8-9	Operation & Tips On Mowing	29
Box Support Frame Assembly Installation	10	Disengagement Of The PTO Assembly	29
Frame Support Brace Installation	11	Unloading The Collection System	29
Box Assembly Installation	12	IV MAINTENANCE	29-30
Box Handle Assembly & Installation	13	Maintenance Checklist	29
Dump Mechanism Adjustment	13	Lubrication	30
Engine Mount Arm Installation	14	V PARTS AND SERVICE	30
Engine/Blower/Blade Installation	15	Parts And Service Information	30
Inlet, Inlet Ring & Debris Deflector Installation	16	Torque Specifications	31
Wiring Kit Assembly Installation	17-18	Troubleshooting	32
Blower Cone Installation	19		
Boot Kit Installation	19		

SAFETY

1. Read the operator's manual carefully and familiarize yourself with the proper use of your attachment. Do not allow anyone who is not acquainted with the Safety Instructions to use your attachment.
2. Know the controls and how to stop quickly. **READ THE OPERATOR'S MANUAL!**
3. Do not allow children to operate the mower. Do not allow adults to operate the mower or grass collection system without proper instruction.
4. Be especially watchful of children and pets darting into the area while operating.
5. Keep your eyes and mind on your unit while mowing or operating your attachment. Don't let others distract you.
6. Do not attempt to operate your unit or mower when not in the driver's seat.
7. Always stop unit when emptying the container.
8. Stop unit, shut off deck attachment, set parking brake, shut off mower engine and remove spark plug wire before removing clogs, removing or replacing hose, boot, blower cone, or performing any maintenance.
9. If a slope must be ascended, back up the slope; drive forward when descending.
10. It is recommended that the container be kept only half full when negotiating any slopes. Start mowing on slopes when the container is empty and never mow slopes greater than 15 degrees.
11. Inspect your lawn and remove any foreign objects before mowing. Never deliberately run the mower across any foreign object.
12. Wear ear protection if the noise level is offensive.
13. Wear eye protection to prevent debris from damaging your eyes.

SAFETY

WARNING! NEVER operate the mower unless the discharge guard and either the deflector assembly or the vacuum collector adapter are fastened securely in place.

WARNING! Do not work around the mower deck boot or the blower area until you are certain that the mower blades and the blower impeller have stopped rotating.

WARNING! To avoid serious injury, perform maintenance on the vacuum collector; **ONLY AFTER STOPPING THE MOWER'S ENGINE AND WAITING FOR ALL MOVING PARTS TO COME TO A COMPLETE STOP.** Set the parking brake. Always remove the ignition key before beginning maintenance.

WARNING! For your own personal safety, **ALWAYS mow ACROSS the face of slopes and NEVER UP and DOWN the face. NEVER attempt to mow excessively steep slopes, and use caution when turning on any slope.**

Safety Alert Symbol



This Safety Alert Symbol means: **“ATTENTION! BECOME ALERT! YOUR SAFETY IS INVOLVED!”**

This symbol is used to call attention to safety precautions that should be followed by the operator to avoid accidents. When you see this symbol, carefully read the message that follows and heed its advice. Failure to comply with safety precautions could result in death or serious bodily injury.

Safety Signs

The signal words **DANGER**, **WARNING**, and **CAUTION** are used on the equipment safety signs. These words



White letters on **RED**

This signal word indicates a potentially hazardous situation which, if not avoided, will result in death or serious injury.



Black letters on **ORANGE**

This signal word indicates a potentially hazardous situation which, if not avoided, could result in death or serious injury.

It may also be used to alert against unsafe practices.



Black letters on **YELLOW**

This signal word indicates a potentially hazardous situation which, if not avoided, will result in minor or moderate injury.

It may also be used to alert against unsafe practices.

PECO LIMITED WARRANTY FOR NEW PRODUCTS

New PECO, Inc. extends the following warranties to the ORIGINAL PURCHASER of each New PECO, Inc. consumer product purchased from one of our Dealers or directly from New PECO, Inc., subject to the following limitations:

A. ITEMS COVERED UNDER WARRANTY

1. **PRODUCT WARRANTY** – Any part or parts which are deemed defective in material or workmanship, as delivered to the original purchaser, will either be repaired or replaced, as New PECO, Inc. elects, without charge for parts or labor, if the defect appears within 12 months from the date of purchase of the product to the Original Purchaser.
2. **PARTS REPLACED DURING WARRANTY** – Any New PECO, Inc. part which is furnished in performance of this warranty and is defective in material or workmanship as delivered to the purchaser will be repaired or replaced, as New PECO, Inc. elects, before the expiration of the original warranty period.

B. WARRANTY DISTINCTIONS

1. **RESIDENTIAL** - Products put to a personal use around a single household or residence are considered Residential. Products designated as “Residential” are warranted for 12 months from the date of purchase of the product, to the ORIGINAL PURCHASER with proof of purchase, when used for or in residential applications.
2. **COMMERCIAL** – Products put to any business use (agricultural, commercial or industrial) or used at multiple locations are considered Commercial. Products designated as “Commercial” are warranted for 12 months from the date of purchase of the product, to the ORIGINAL PURCHASER with proof of purchase, when used for or in commercial applications. Products designated as “Residential” are warranted for 90 days from the date of purchase of the product, to the ORIGINAL PURCHASER with proof of purchase, when used for or in Commercial applications.
3. **RENTAL** – Products used for Rental or Lease Purposes are warranted for 45 days from date of purchase of the product, to the ORIGINAL PURCHASER with proof of purchase, when used for or in a rental business.

C. ITEMS NOT COVERED BY NEW PECO WARRANTY

1. **ENGINES & BATTERIES:** Engines and Batteries attached to New PECO, Inc. products are covered under their respective separate manufacturer warranties and those companies must be contacted directly to file a warranty claim. Briggs & Stratton: https://www.briggsandstratton.com/na/en_us/support/warranty.html
2. **UNAPPROVED ALTERATION OR MODIFICATION:** All obligations of New PECO, Inc. under this warranty shall be terminated if products are altered or modified in any way not approved by New PECO, Inc.
3. **ACCIDENTS & NORMAL MAINTENANCE:** This warranty covers ONLY manufacturers defective material and workmanship. It does not cover depreciation or damage caused by normal wear & tear, accident, improper maintenance, misuse or abuse of products. New PECO, Inc. products must be operated and maintained in accordance with the instructions furnished in the manuals. The cost of normal maintenance and normal replacement of service items such as belts, cutting blades, hoses, bags, etc., which are not defective shall be paid for by the purchaser.
4. **NO SERVICE CENTER WARRANTY:** The selling Service Center/Dealer makes no warranty on his own on any item warranted by New PECO, Inc. unless he delivers to purchaser a separate written warranty certificate specifically warranting the item. The Service Center or Dealer has no authority to make any representation or promise on behalf of New PECO, Inc. or to modify the terms of the original warranty in any way.
5. **NO REPRESENTATIONS ADDITIONAL WARRANTIES, DISCLAIMER:** Neither New PECO, Inc. nor any company affiliated with New PECO, Inc. makes any warranties, representations or promises as to the quality of performance of its products other than those set forth herein. Except as described above, New PECO, Inc. makes no other warranties **AND SPECIFICALLY DISCLAIMS ANY AND ALL IMPLIED WARRANTIES OF FITNESS AND MERCHANTABILITY.**
6. **REMEDIED EXCLUSIVE:** The only remedies the purchaser has in connection with the breach or performance of any warranty on New PECO, Inc. consumer products are set forth above. In no event will New PECO, Inc. be liable for special incidental or consequential damages.

Warranty service is available through your local authorized service dealer or distributor. If you do not know the dealer or distributor in your area, search by your zip code on www.lawnvac.com or contact our Sales Department at New PECO, Inc. 800-438-5823 or email Sales@lawnvac.com.

Section I - INTRODUCTION AND DESCRIPTION

Introduction

We are pleased to have you as a PECO customer. Your collection system has been designed to give you a low maintenance, simple, and effective way to collect the grass clippings from your mower. This manual is provided to give you the necessary instructions to properly mount and operate the collection system on your mower. Please read this manual thoroughly. Understand what each control is for and how to use it. Observe all safety decal precautions on the machine and noted throughout the manual.

NOTE: all references made to right, left, front, rear, top or bottom are as viewed from the normal operator's position on the mower.



CAUTION

**To Prevent Damage to the Engine-
Check your Engine Oil Level Before Operation
and Add Engine Oil as directed by
your Engine's Owner's Manual**

Description

The collection system is designed for turf maintenance where there is a need to collect the grass clippings as the mower cuts the turf. It is also good for picking up leaves and twigs in pre-season and post-season clean-up.

The engine/blower/blade assembly, is mounted on the right side of the unit. The blower draws grass clippings from the discharge area of the cutter deck up and back to the aluminum container mounted over the rear portion of the mower frame. The operator can engage the engine/blower/blade assembly by starting the engine. Once the container is full of clippings, the operator can easily pull and raise the lift handle. Using the lift handle, the operator releases the rear door, the container pivots towards the ground, and the clippings are dumped.



Section II - INSTALLATION FOR USE

Preparation Of Mower

Carefully dismantle wooden shipping crate from around the components. Cut retaining straps and separate the parts. The collection system will have various parts located inside. Remove and sort all parts for easy identification.

NOTE: Before each step of assembly it will help to study the exploded drawings.

Battery Cover Removal

The plastic battery cover should be removed to allow for access when unit is fully assembled. Start by loosening the two wing nuts on both sides of the cover and remove the cover. See Figure A.

Figure A

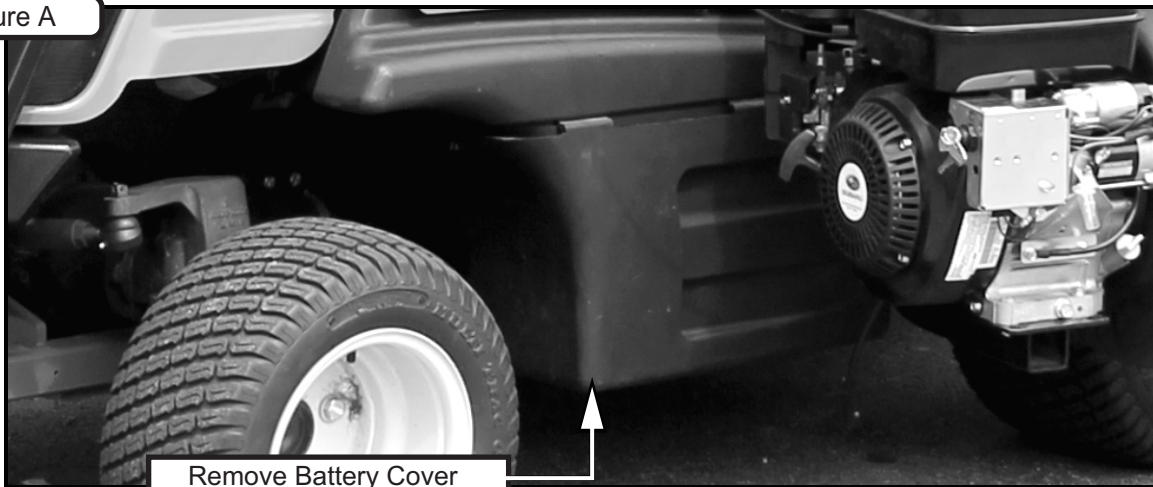

Rear Main Frame Installation

Note: It is recommended that someone assist you in attaching the rear Main Frame Channel P#(B2103).

Lift the Main Frame Channel P#(B2103) into position aligning the right set of mounting holes on the Main Frame Channel with the existing holes on the rear bumper of the mower, as shown in Figure B.

Figure B

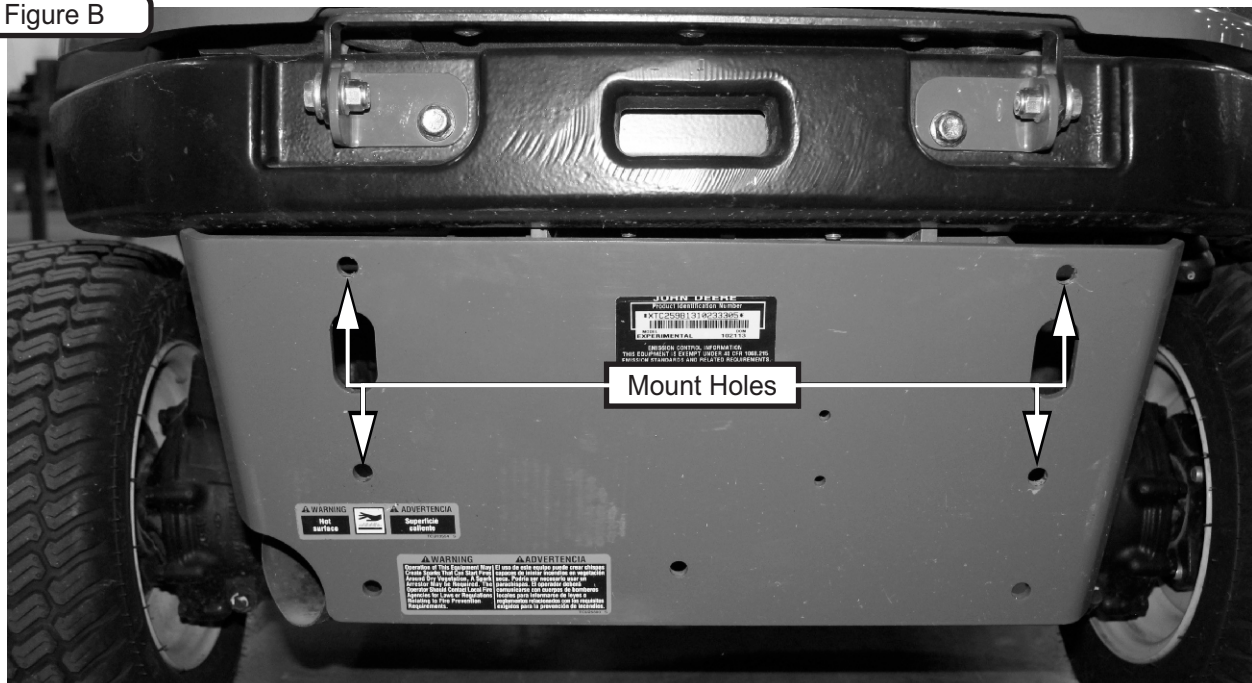

Rear Main Frame Installation (Cont.)

Secure the Main Frame Channel to the rear bumper by using (4) 7/16"-14 x 1" HHCS P#(K1458) and (4) 7/16"-14 Flange Nuts P#(K1459). See Figure C.

Note: Some parts and part features have been hidden from view for visual clarity.

Figure C

Main Frame Channel

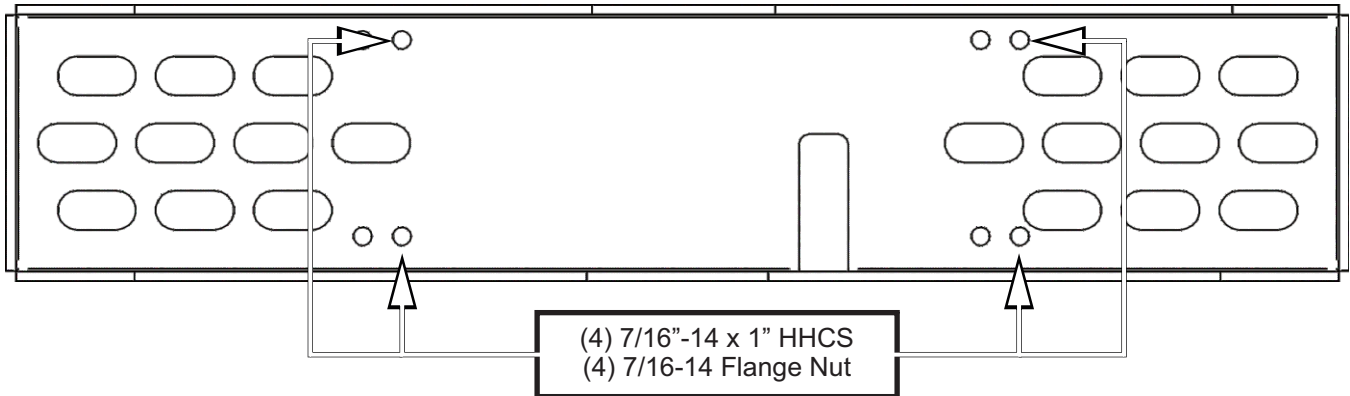

With the Main Frame Channel (Item #1) installed, install (1) Frame Side (Item #2) to either the right or left side of the Main Frame Channel.

Align the lower (3) bolt holes of the Frame Side to the (3) bolt holes on the side of the Main Frame Channel and secure the Frame Side by using (3) 1/2"-13 x 1-1/4" HHCS (Item #4) and (3) 1/2"-13 Flange Nuts (Item #3).

See Figure D. Repeat the previous step on the other side of the Main Frame Channel.

Note: Keep hardware relatively loose until the installation of the Box Support Frame Assembly P#(A0579_01).

Figure D

Item #	Part #	Desc.	Qty.
1	B2103	Main Frame Channel	1
2	B2105	Frame Side	2
3	K1246	Flange Nut 1/2"-13	6
4	K0342	1/2"-13 x 1-1/4" HHCS	6

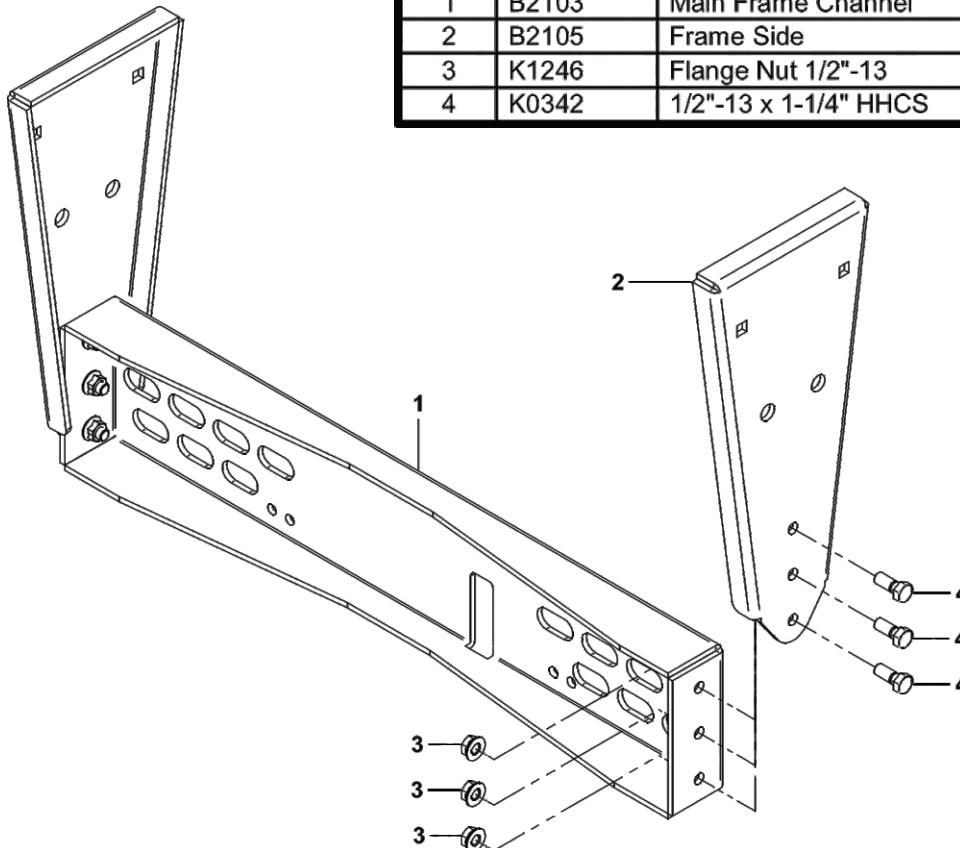

Frame Support Brace Installation

Position the Frame Support Brace P#(B0212) onto the rear side of the mower's ROPS and raise the Frame Support Brace into position with the pins on the Box Support Frame. Position the ROPS so that they are sitting between the (2) mount holes as shown in Figure B.

Secure the Frame Support Brace to the ROPS by using (2) 3/8"-16 x 3" U-Bolts P#(K1432) and (4) 3/8"-16 Ny-Flange Locknuts P#(K2038). Refer to Figure A.

Note: Some parts and part features have been hidden from view for visual clarity.

Figure A

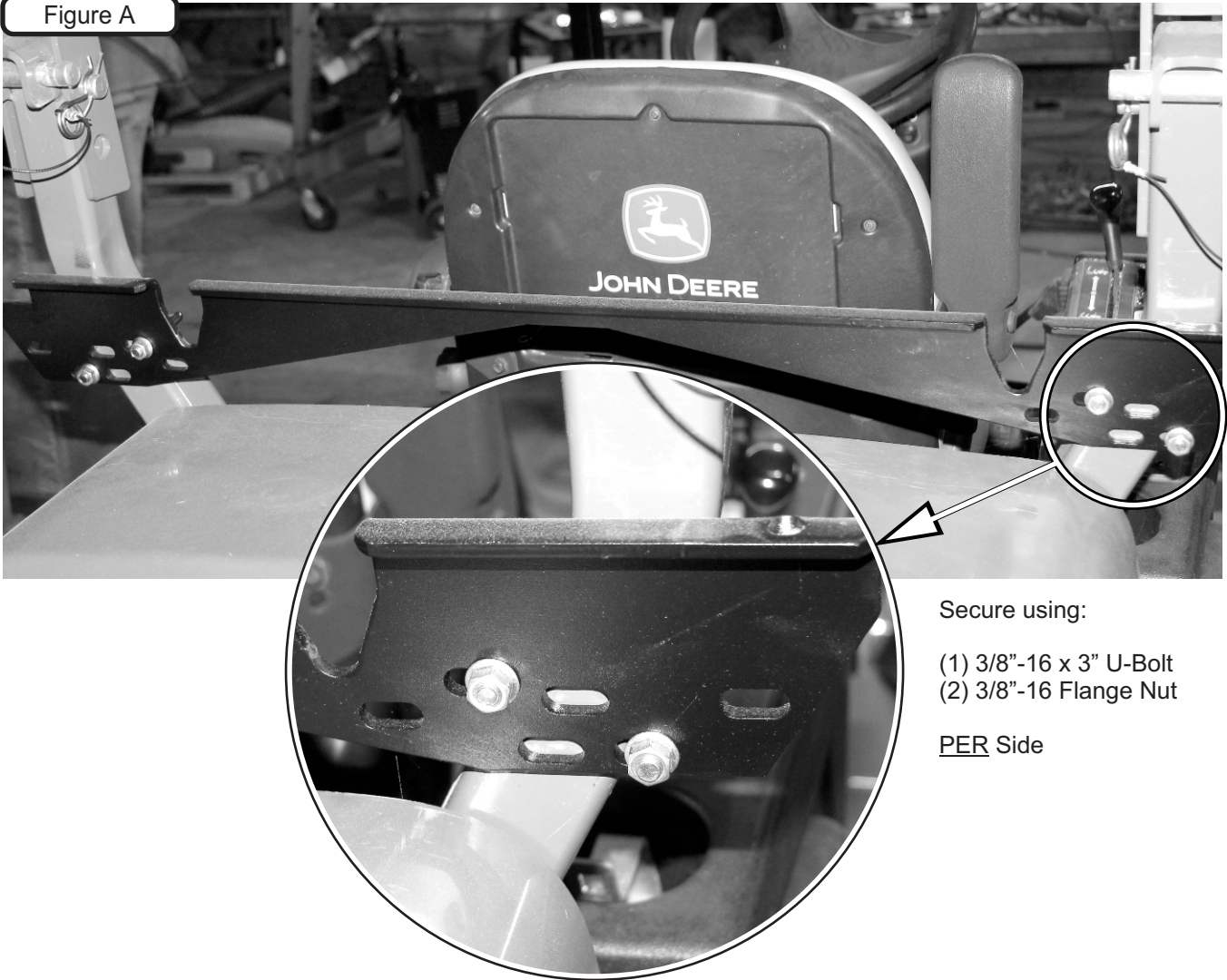
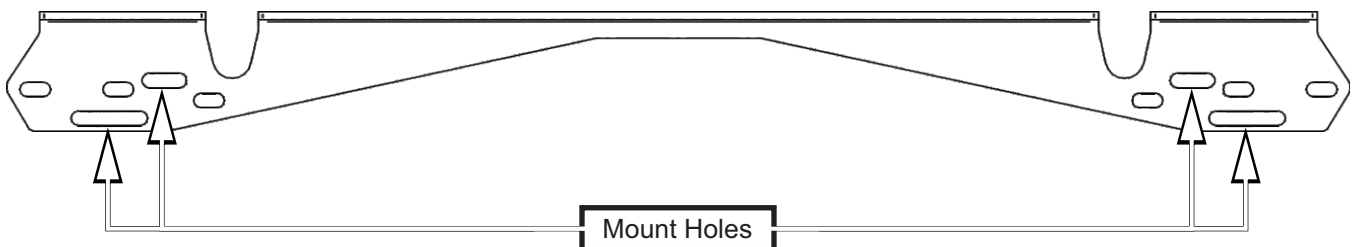

Figure B

Frame Support Brace



Box Support Frame Assembly

First, prepare the Frame Brace / Box Support Frame (Item #1) by installing (2) 5/8"-11 x 7-1/2" HHCS (Item #2), (2) 5/8"-11 Hex Nut (Item #3) and (2) 5/8"-11 Flange Nuts (Item #4). Thread the 5/8"-11 x 7-1/2" HHCS into the Hex Nut then secure the bolt to the Frame Brace by using the Flange Nut as shown in Figure A.

Note: Some parts and part features have been hidden from view for visual clarity.

Figure A

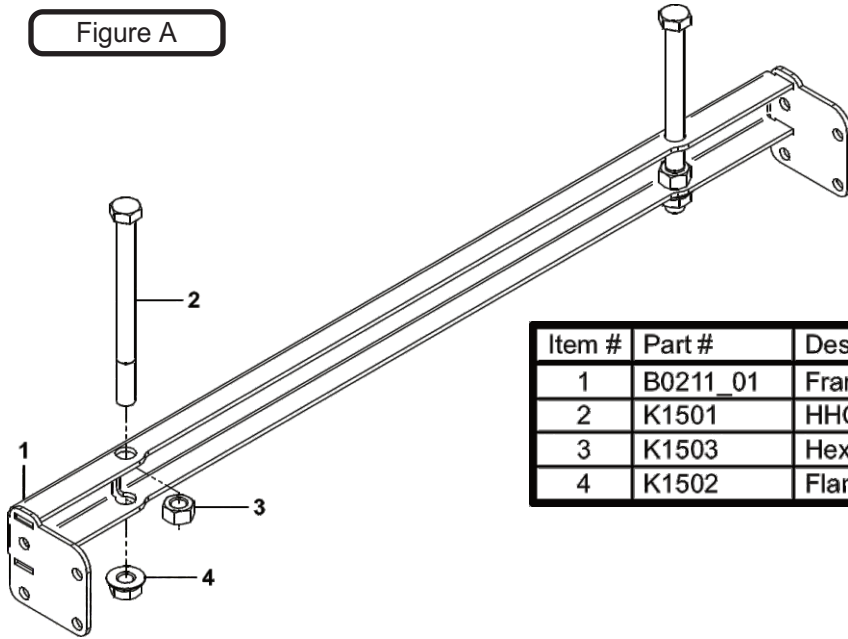

Item #	Part #	Desc.	Qty.
1	B0211_01	Frame Brace / Box Support Frame	1
2	K1501	HHCS / 5/8"-11 x 7-1/2" GR5 Zinc	2
3	K1503	Hex Nut / 5/8"-11	2
4	K1502	Flange Nut / 5/8"-11	2

Then, referring to Figure B, install the Lt. Tube Assy / Box Support Frame (Item #1) to the Lt. Leg / Box Support Frame (Item #2) by using (2) 3/8"-16 U-Bolts (Item #3) and (4) 3/8"-16 Ny-Flange Lock Nuts (Item #4). When installing the Tube Assy, be sure the Tube Edge and Leg Bracket Edge are flush to one another and the bend of the Leg Bracket also rests flush under the Tube as shown below.

Repeat step for the Rt. Tube Assy / Box Support Frame P#(A2341) & Rt. Leg / Box Support Frame P#(B0209_01).

Figure B

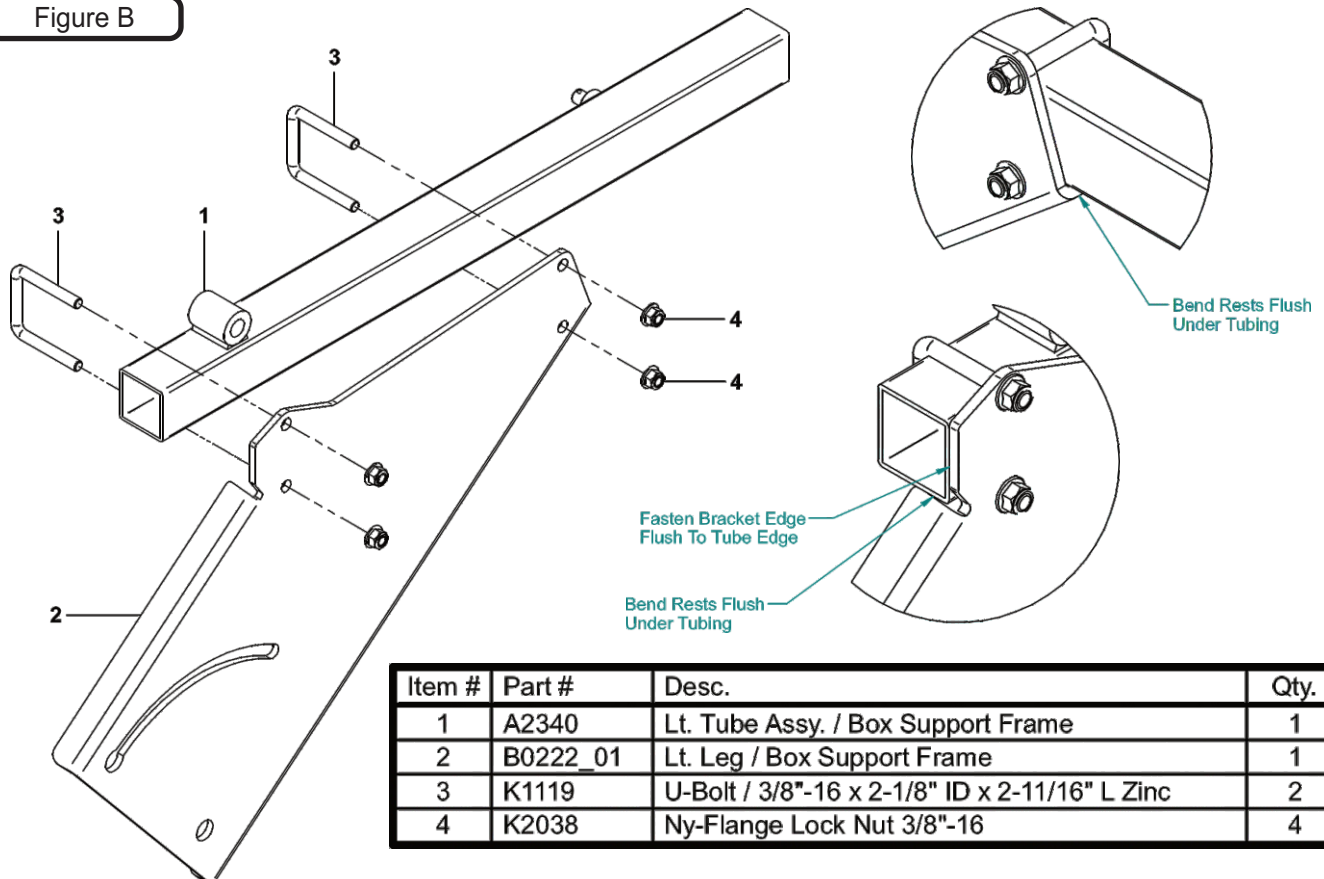

Item #	Part #	Desc.	Qty.
1	A2340	Lt. Tube Assy. / Box Support Frame	1
2	B0222_01	Lt. Leg / Box Support Frame	1
3	K1119	U-Bolt / 3/8"-16 x 2-1/8" ID x 2-11/16" L Zinc	2
4	K2038	Ny-Flange Lock Nut 3/8"-16	4

Box Support Frame Assembly (Cont.)

Finally, install the assembled Lt. Tube Assy (Item #1) to the left side of the Frame Brace (Item #2) by using (2) 3/8"-16 U-Bolts (Item #4) and (4) 3/8"-16 Ny-Flange Lock Nuts (Item #5). Be sure the Tube Edge is flushed against the Frame Brace Edge as shown in Figure C below.

Repeat the steps for the assembled Rt. Tube Assy (Item #3) on the right side.

Figure C

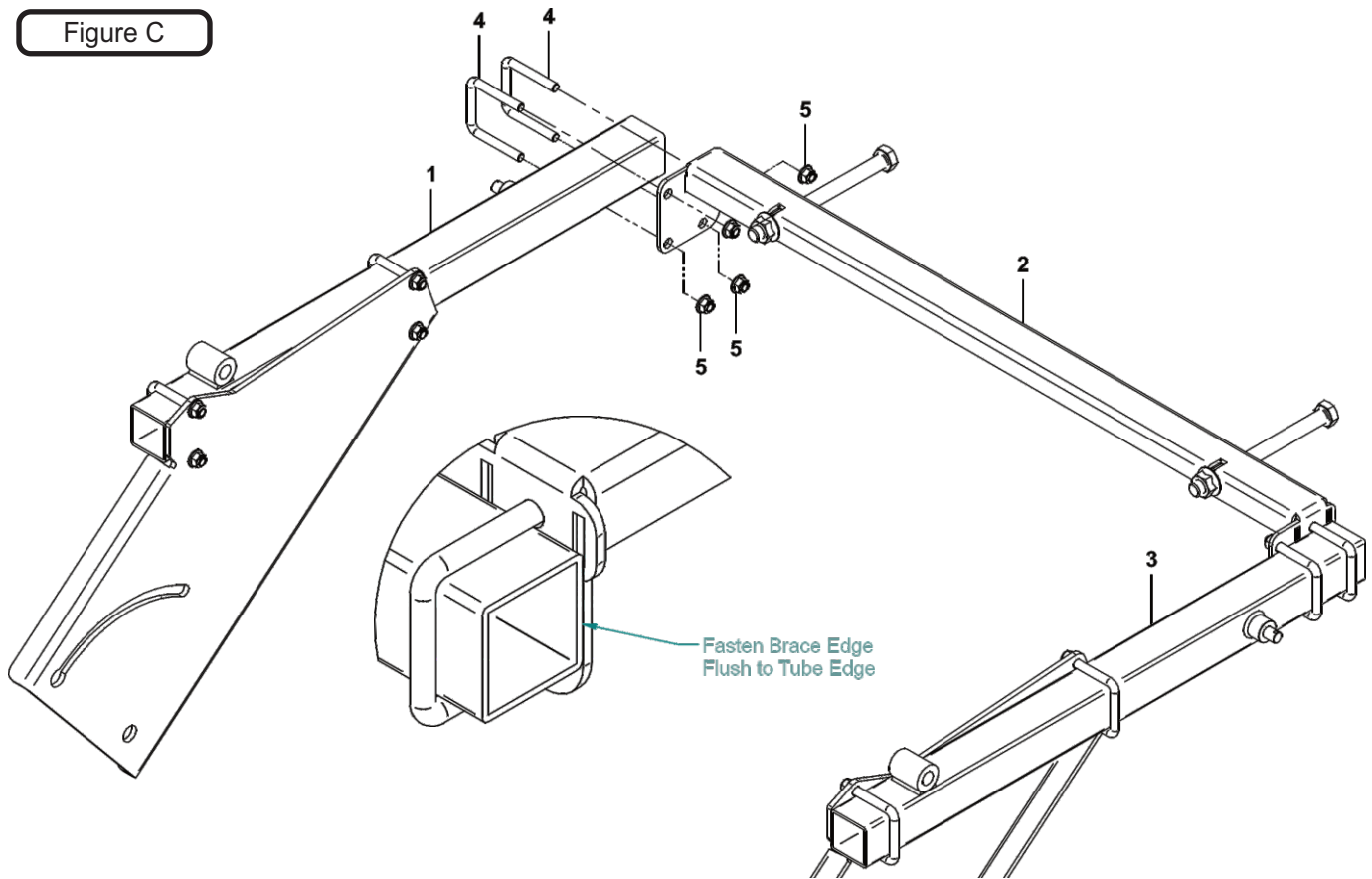

Item #	Part #	Desc.	Qty.
1	A2340	Lt. Tube Assy. / Box Support Frame	1
2	B0211_01	Frame Brace / Box Support Frame	1
3	A2341	Rt. Tube Assy. / Box Support Frame	1
4	K1119	U-Bolt / 3/8"-16 x 2-1/8" ID x 2-11/16" L Zinc	4
5	K2038	Ny-Flange Lock Nut 3/8"-16	8

Figure D

Assembled Box Support Frame Assy

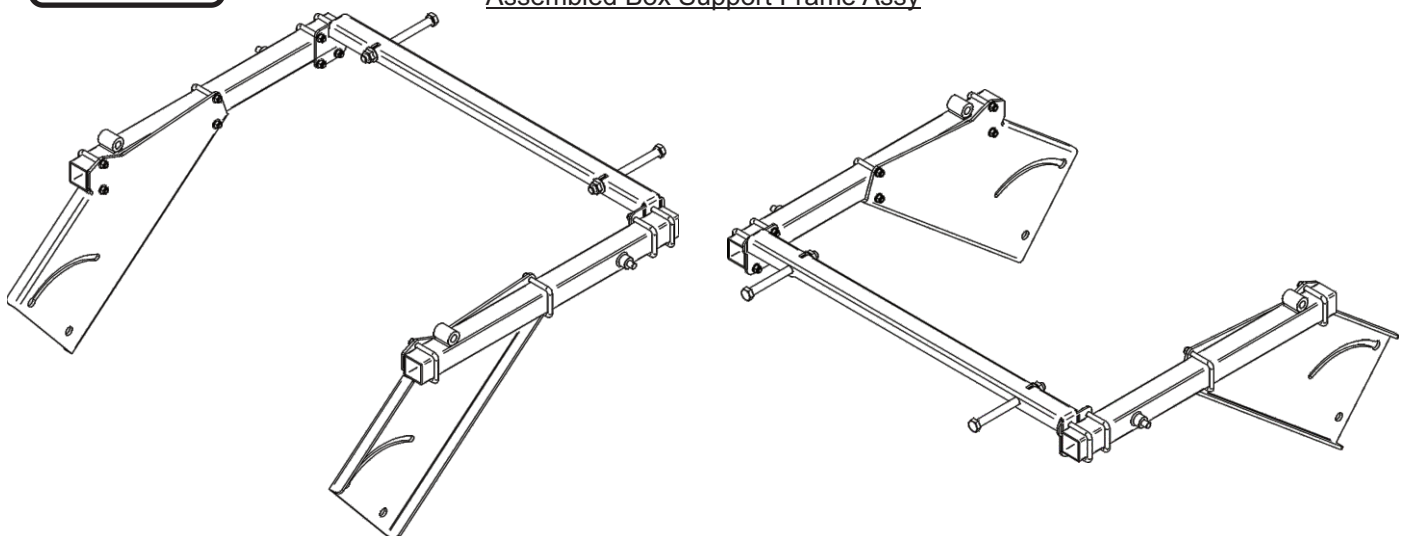

Box Support Frame Assembly Installation

Note: It is recommended that someone assist you in the installation of the Box Support Frame Assy (Item #1).

First, align the lower bolt hole of the Left or Right Leg of the Box Support Frame Assembly (Item #1) to the bolt hole of the Frame Side (Item #2). Secure the Left or Right Leg to the Frame Side by using (1) 3/4"-10 x 1-3/4" HHCS (Item #3), (1) 3/4" Flat Washer (Item #4) and (1) 3/4"-10 Nyloc Nut (Item #5) PER Leg. See Figure A. Leave hardware relatively loose until the end of this step.

Next, align the square bolt hole of either left or right Frame Side (Item #2) to the pivot channel of the Left or Right Leg of the Box Support Frame Assy (Item #1). Secure the Left or Right Leg to the Frame Side by using (1) 1/2"-13 x 1" Carriage Bolt (Item #6) and (1) 1/2"-13 Adjustable Handle (Item #7) PER Leg. See Figure A.

Finally, push the entire assembly forward positioning and resting the front (2) bolts within the Frame Support Brace as shown in Figure B. Once in place, tighten the 3/4"-10 x 1-3/4" HHCS pivot bolt to secure the Box Support Frame Assembly while still allowing the Box Support Frame Assembly to move freely.

Note: Some part and part features have been hidden from view for visual clarity.

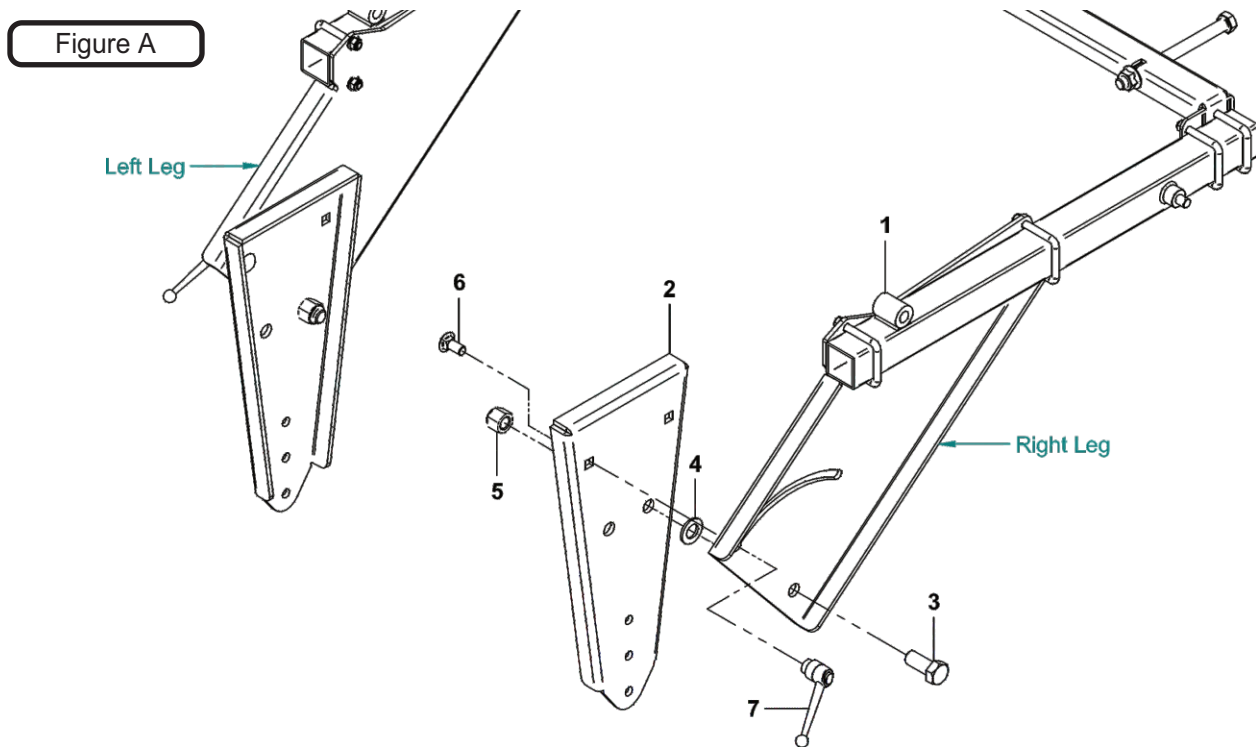

Item #	Part #	Desc.	Qty.
1	A0579_01	Box Support Frame Assy.	1
2	B2105	Frame Side	2
3	K1486	HHCS 3/4"-10 x 1-3/4" GR8	2
4	K0061	3/4" Flat Washer / 1.486 OD x .810 ID x .147 T	2
5	K1433	Nyloc Nut 3/4"-10 GR5	2
6	K1238	1/2"-13 x 1" Carriage Bolt / Zinc / GR5	2
7	J0012	Adjustable Handle 1/2"-13 Female	2

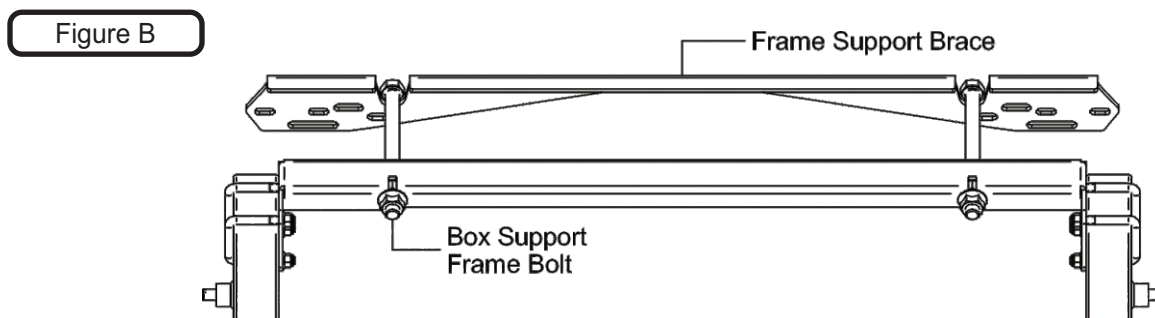

Box Assembly Installation

Note: It is recommended that two people assist you in the installation of the Box Assembly (Item #1).

Lift the Box Assembly (Item #1) and position the frame by aligning the Box Assy Pivot Brackets with the Pivot Bushing of the Box Support Frame Assembly (Item #2). See Figure A.

Secure the Box by inserting (2) Clevis Pins (Item #3) from the outside of the Box Assy and fastening with (2) 5/8" Flat Washers (Item #4) and (2) Hair Pin Clips (Item #5). See Figure A.

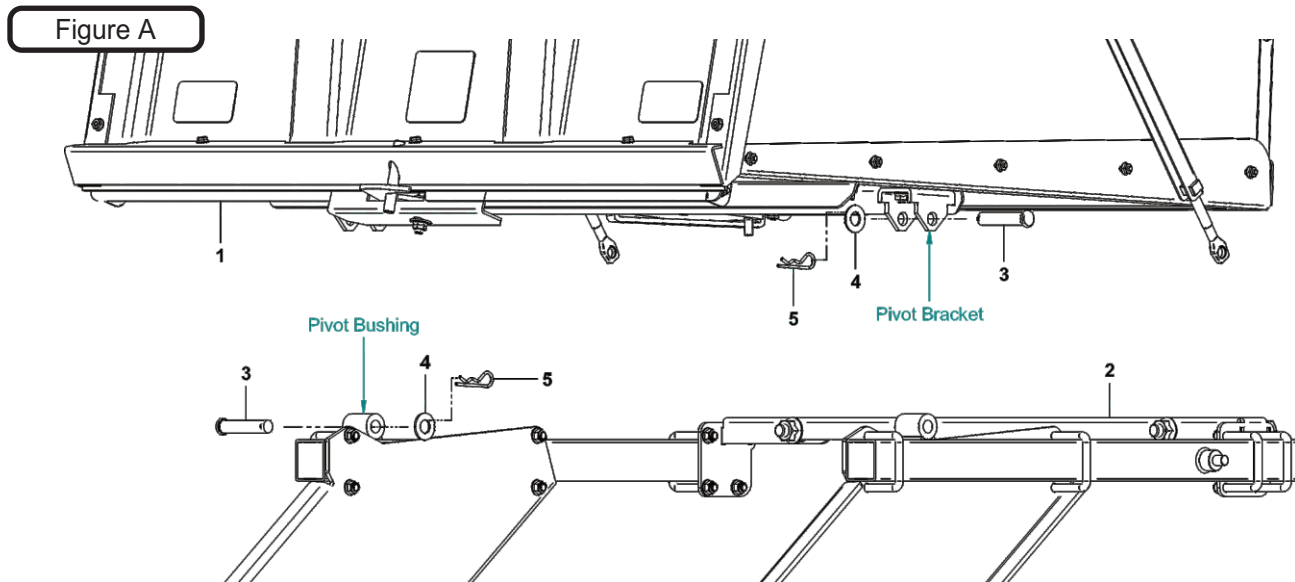

Item #	Part #	Desc.	Qty.
1	A2046_01	Box Assy. / Pro 24 / Generic	1
2	A0579_01	Box Support Frame Assy.	1
3	K0172	5/8" DIA x 3" LONG CLEVIS PIN	2
4	K0058	5/8" Flat Washer	2
5	K0086	Hair Pin Clip .125 OD x 2.50	2
6	K1437	Rue Ring Cotter Pin	2

Position and insert the Linkage Pin of the Box Support Frame Assy (Item #2) to the Adjusting Screw of the Box Assy (Item #1), the Adjusting Screw may need to be adjusted to properly fit the Linkage Pin.

Secure the Adjusting Screw by using (1) Rue Ring Cotter Pin (Item #6). Repeat the procedure on the opposite side. See Figure B below.

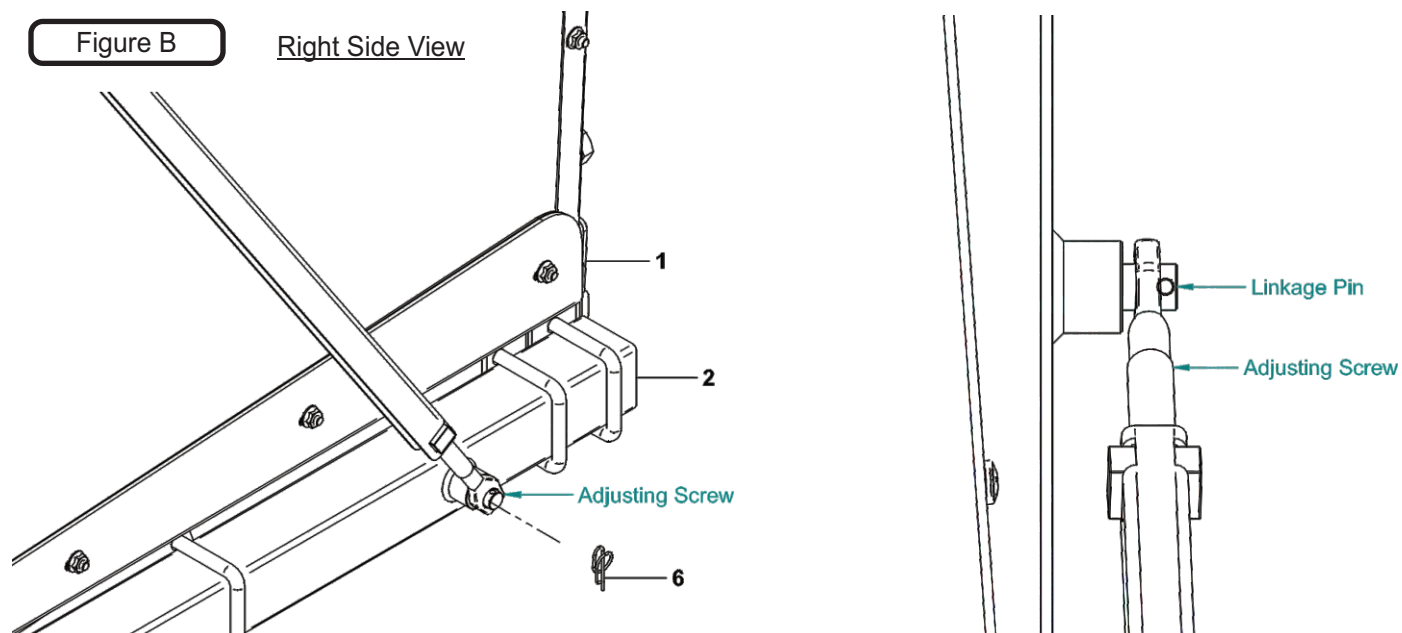

Box Handle Assembly & Installation

The Box Handle is made up of two components, the Base Handle (Item #1) and Handle Extension (Item #2), secured together by a Shaft Coupling (Item #3). See Figure A.

To install the Handle Extension onto the Base Handle, first, secure the Shaft Coupling onto the Base Handle. The Shaft Coupling has (2) sets of set screws, position the Shaft Coupling so that (1) set screw will tighten onto the Base Handle and secure the set screw, refer to Figure B. Next, insert the Handle Extension from the opposite end of the Shaft Coupling and securing the Handle Extension by setting and tightening the second set screw. Refer to Figure B.

Note: Some parts and part features have been hidden from view for visual clarity.

Figure A

Item #	Part #	Desc.	Qty.
1	A2334	P24 Box Base Handle	1
2	B2102	Pro 24 Handle Ext	1
3	B2100	Shaft Coupling	1
4	J0522	Handle Grip / Round Black / .800 ID	1

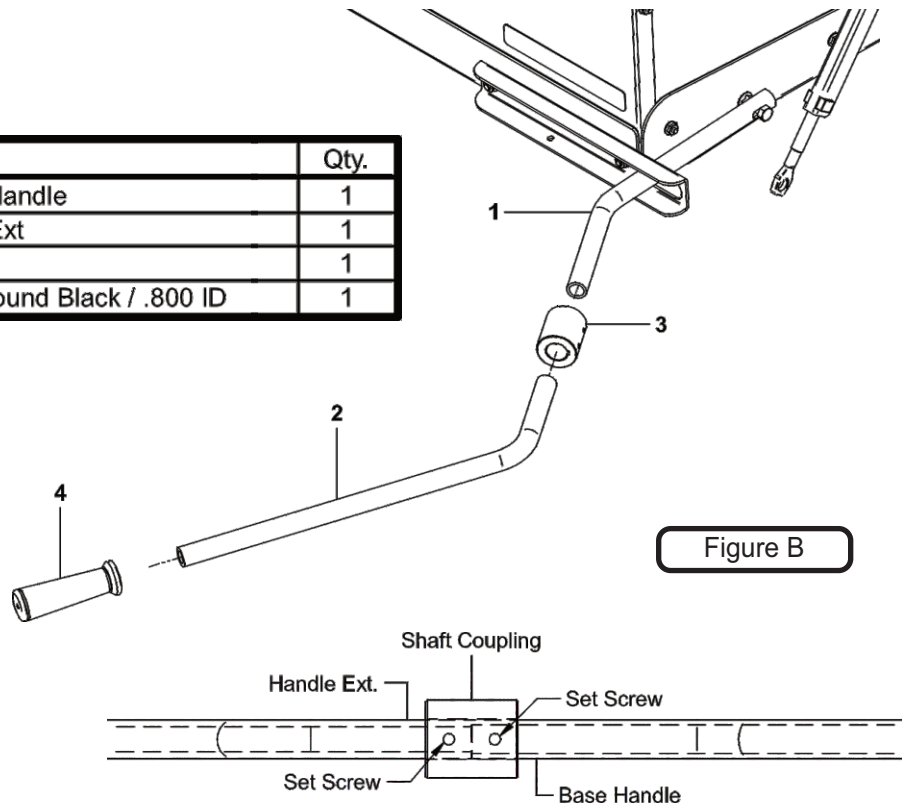

Figure B

Note: Secure the set screw over the Handle Extension relatively loose then adjust & position the handle to your preference before tightening

Dump Mechanism Adjustment

The linkage rods may be adjusted at the adjusting screw and at the latch assembly. To change the door closure tightness, thread the adjusting screw clockwise to loosen the contact between the door and the box, or counter-clockwise to tighten the contact between the door and the box.

To adjust the latch, change the length of the latch rod by threading the latch rod in or out of the adjusting ball joint. The latch hook pivot should be in the middle of the slot in the latch hook pivot plate. Slide the pivot back and forth, then tighten so the door opens and closes while still having a tight seal between the door and the box. See Figure C.

Figure C

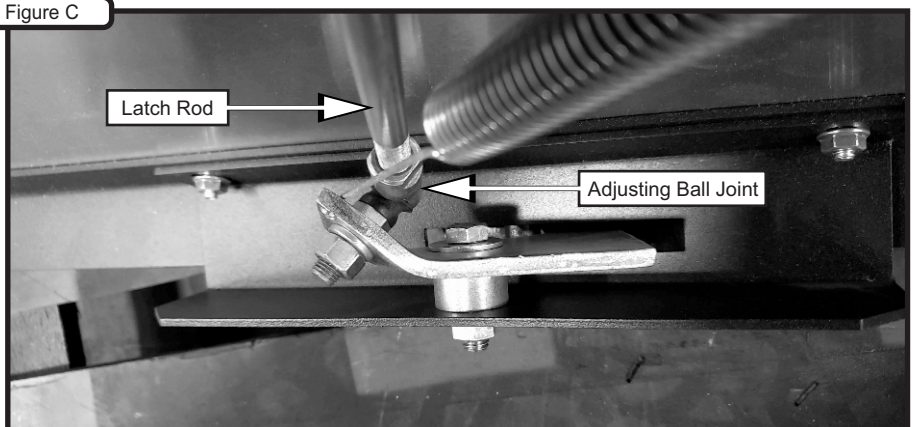

Engine Mount Arm Installation

Slide the inner portion of the Engine Mount Assembly P#(A2022_01) behind the front right wheel and in front of where the battery housing cover was located. Fasten the Engine Mount Assembly to the frame by using (2) 1/2"-13 x 4-5/16 x 2-3/4 U-Bolts P#(K0289) around the frame and into the bolt holes on the Mount Plate and secure LOOSELY with (4) 1/2"-13 Ny-Flange Locknuts P#(K2012). See Figure B.

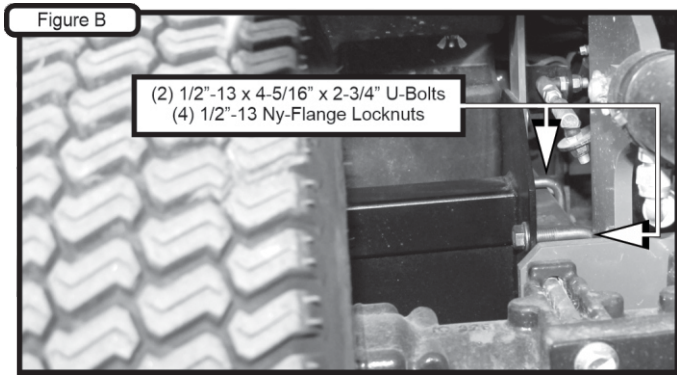

Engine Mount Arm Installation Cont.

While pulling out on the locking pin, slide the outer portion of the Engine Mount arm assembly over the tube from the inner portion. Reinstall the battery box and verify clearance from the engine, adjust as needed. Tighten U-Bolts from previous step. Turn the locking handle to secure outer portion. This handle can be pulled outward to reset the position. It should be horizontal when secure to maintain maximum ground clearance. Continue on to engine installation.

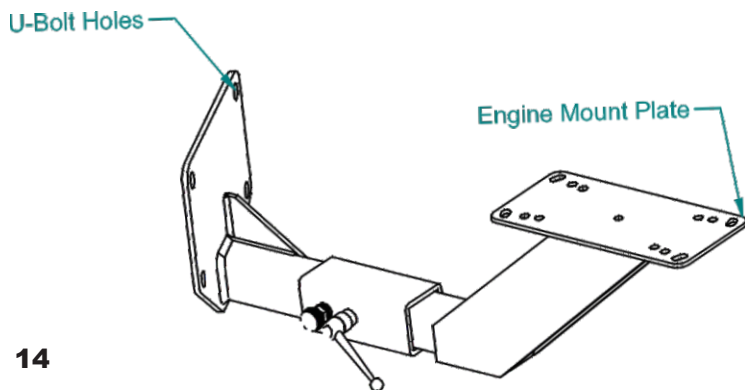

Engine/Blower/Blade Assembly Installation

Before mounting the Engine/Blower/Blade Assembly (Item #1) onto the Engine Mount Arm Assembly (Item #4), place it onto the Inner Engine Mount Weldment (Item #3) until the Knob Plunger Pin engages. Once in place, turn Lock Handle clockwise until tight. Next place (2) Rubber Shock Absorbers (Item #2) between the Engine Mount Arm and Base of the Engine. Align the bolt holes of the rubber pads with the bolt holes of the Engine Mount Arm. See Figure A, Figure B, and Figure C.

Place the Engine/Blower/Blade Assembly (Item #1) onto the Engine Mount Assy (Item #4) and align the bolt holes. With the Rubber Shock Absorbers between the Engine and Mount Plate, fasten the Engine using (4) 5/16"-18 x 2-1/4" HHCS (Item #5) and (4) 5/16"-18 Ny-Flange Locknuts (Item #6). See Figure A below.

Figure A

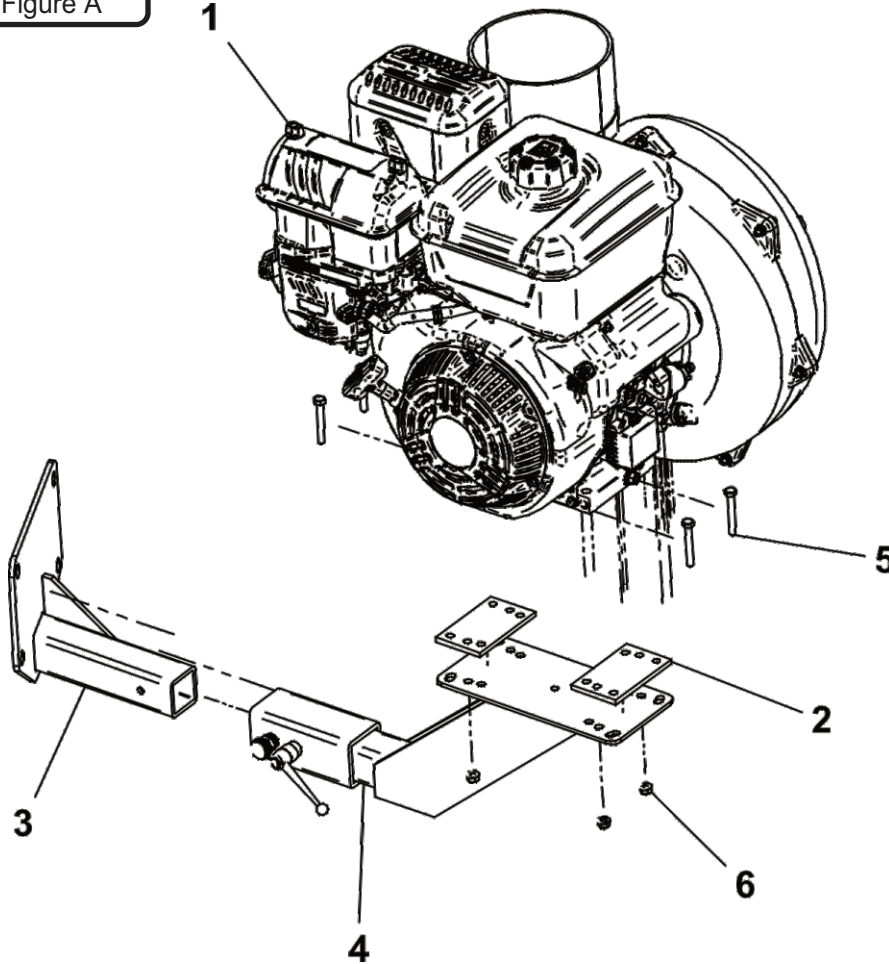
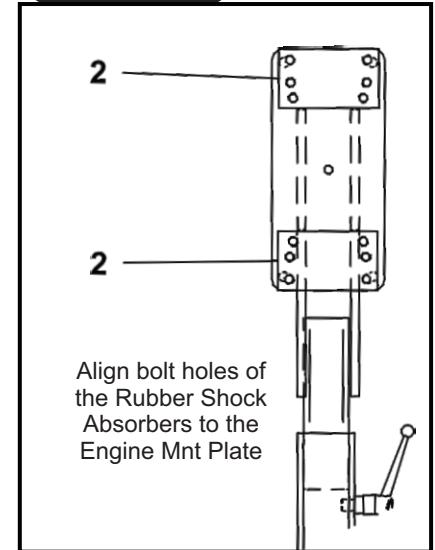
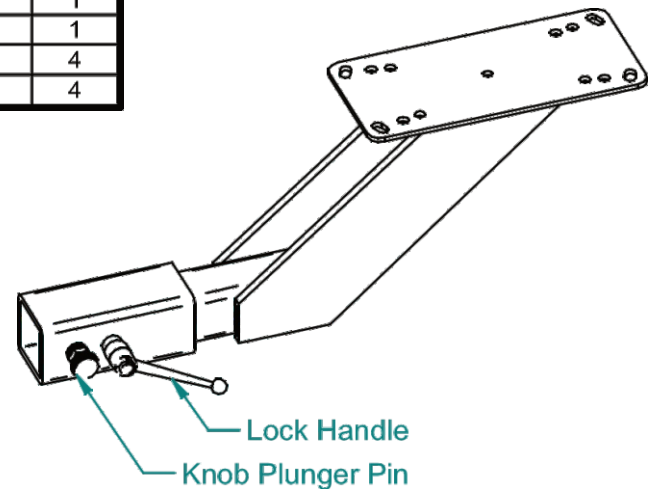

Figure B



Item #	Part #	Desc.	Qty.
1	A620/A640	Engine/Blower/Blade Assy	1
2	V1090	Rubber Shock Absorber	2
3	A2443	Inner Engine Mount Weldment	1
4	A2445	Engine Mount Arm Assy	1
5	K1160	5/16"-18 x 2-1/4" HHCS	4
6	K2516	Ny-Flange Lock Nut 5/16"-18	4

Figure C



Inlet, Inlet Ring & Debris Deflector Installation

Open box door. From inside box, slide Inlet (Item #4) halfway into inlet hole of the Right Box Side (Item #1), see Figure A. Take each half of the Inlet Ring (Item #2) and attach around matching groove in Inlet (Item #4). Slide Inlet (Item #4) & Inlet Ring (Item #2) against inlet hole and align four holes. Fasten Inlet Ring (Item #2) bottom holes using (2) 5/16" IT Tooth Lock Washers (Item #5) & (2) 5/16"-18 x 1/2" HHCS (Item #7) (See Figure B). Fasten Inlet Ring (Item #1) top holes using (2) 5/16" IT Tooth Lock Washers (Item #5) & (2) 5/16"-18 x 1-1/4" HHCS (Item #6). Slide Debris Deflector (Item #3) over inside top bolt threads (Item #7). Fasten Debris Deflector (Item #3) using (2) 5/16"-18 Ny-Flange Lock Nuts (Item #8). Final assembly should resemble Figure C.

Note: Some parts and part features have been hidden from view for visual clarity.

Figure A

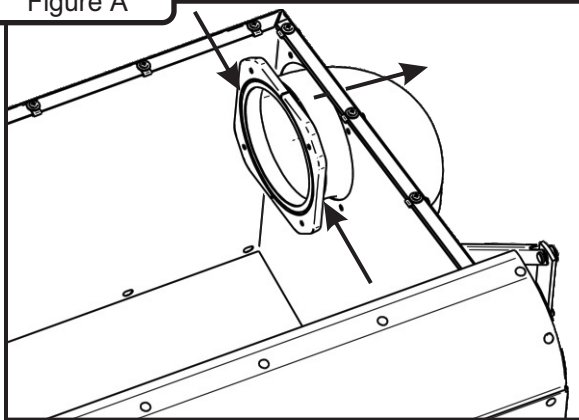

Figure C

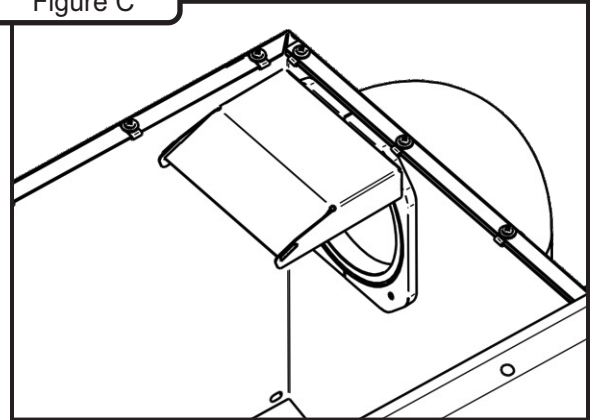
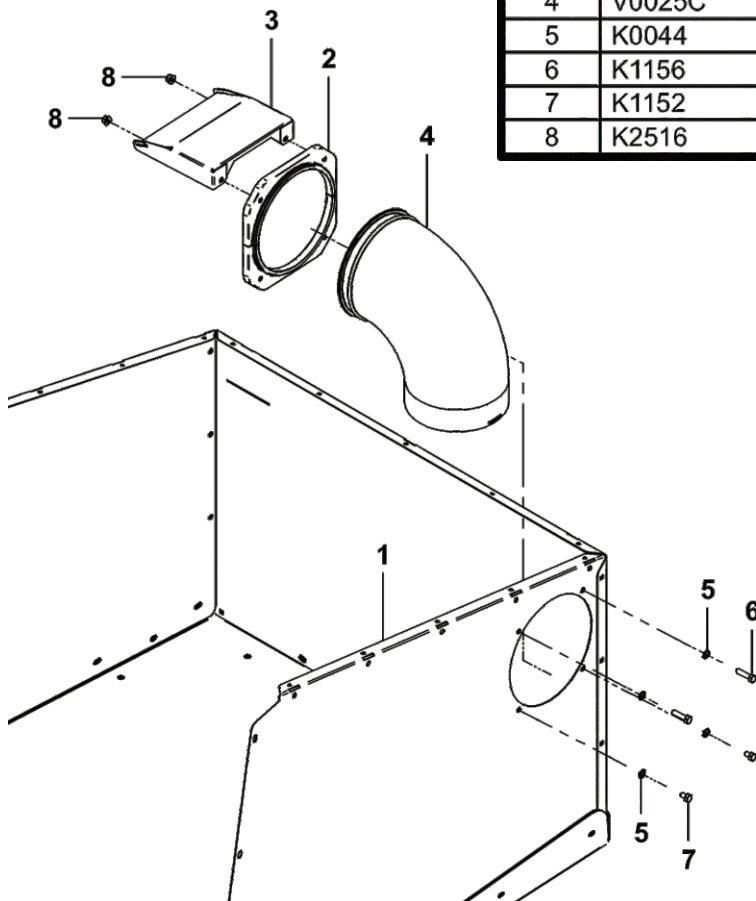

Figure B



Item #	Part #	Desc.	Qty.
1	C0043_01	Box Right Side	1
2	C0074	Inlet Ring	1
3	C0088	Debris Deflector	1
4	V0025C	Universal Inlet / 7"	1
5	K0044	I/T Tooth Lock Washer 5/16"	4
6	K1156	5/16"-18 x 1-1/4" HHCS	2
7	K1152	HHCS 5/16"-18 x 1/2"	2
8	K2516	Ny-Flange Lock Nut 5/16"-18	2

Wiring Kit Assembly Installation

To connect the Wiring Kit P#(A2152), connect the 4 gage Red Wire P#(P0620) to the positive (+) terminal of the starter solenoid on the engine. Route the Red Wire from the solenoid to the positive (+) terminal of the battery.

Connect the 4 gage Black Wire P#(P0621) to one of the mounting bolt holes located on the bottom of the engine. Route the black wire from the bolt hole to the negative (-) terminal of the battery.

Refer to the Figures below for your respective engine.

Once the wires are properly routed, test start the engine. If working properly, secure the wiring with the provided Zip Ties P#(J0245).

Yanmar

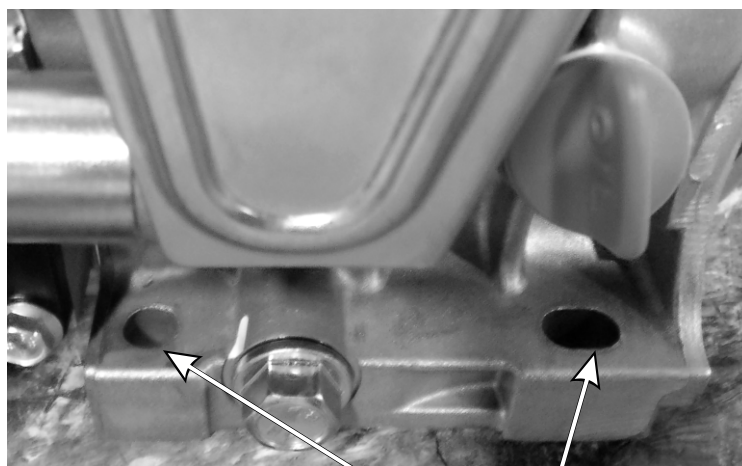
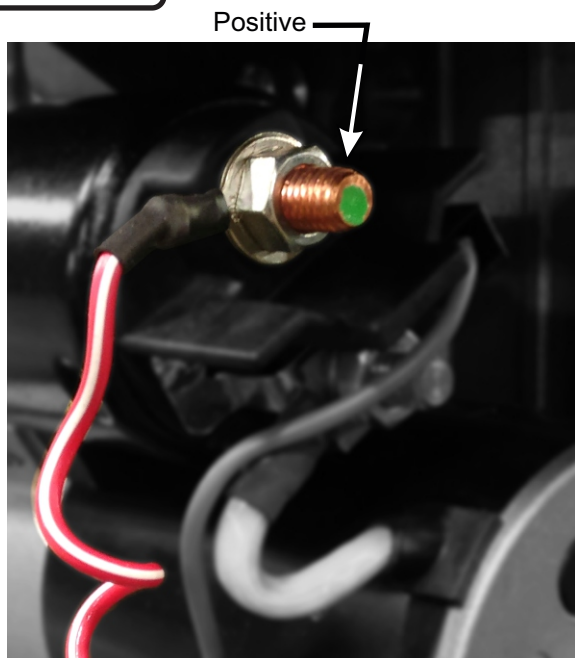

Negative (-) Terminal
Connection
(Engine Block)

Vanguard

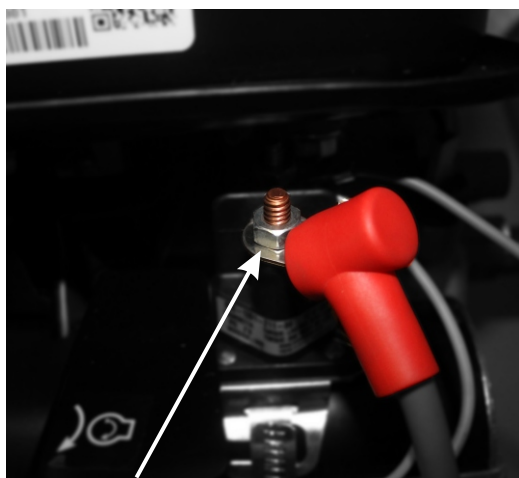

Positive (+) Terminal
Connection (Solenoid)

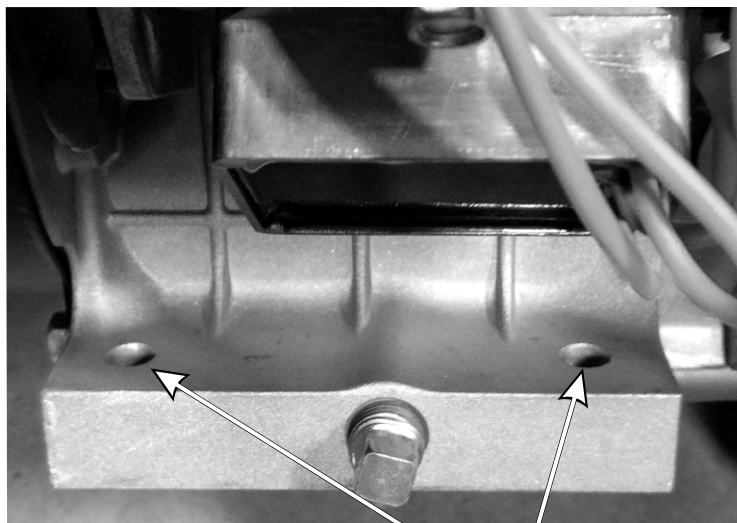

Negative (-) Terminal
Connection
(Engine Block)

Wiring Kit Assembly Installation (Cont.)

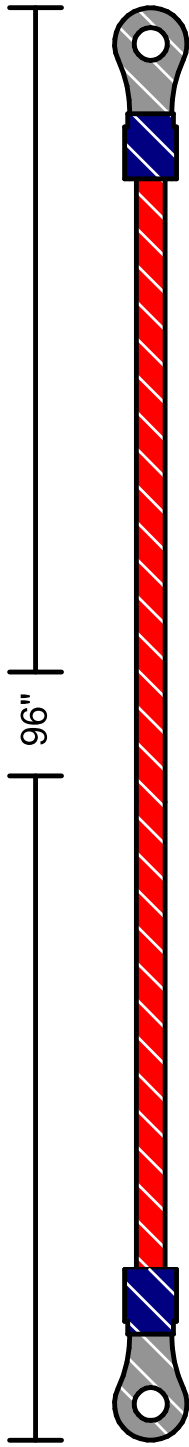

HARNES #:P0620
RED (4 AWG) w/ 5/16" RING TERMINAL
FROM BATTERY POSITIVE "+" TO STARTER SOLENOID "+"

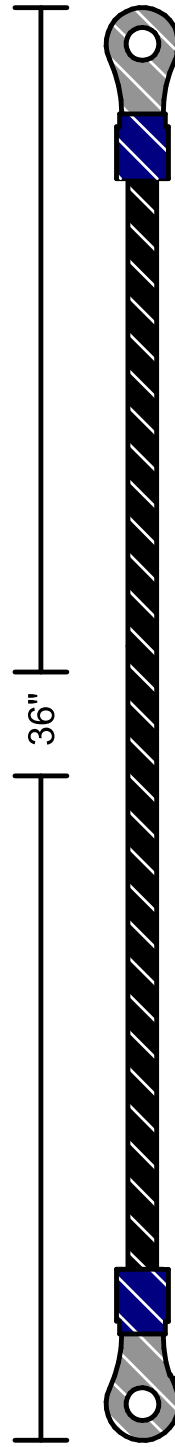

HARNES #:P0621
BLACK (8 AWG) w/ 5/16" RING TERMINAL
FROM BATTERY NEGATIVE "-" TO ENGINE BLOCK "-"

P#:P0076
5/16" BATTERY RING TERMINAL

Blower Cone Installation

Thread (1) 5/16"-18 Jam Nut P#(K0120) onto each end of (2) 5/16"-18 x 2-1/2" HHCS P#(K0125), refer to Figure A. Next, partially thread (1) bolt into each of the two threaded bosses located on the Blower Housing. Position the Blower Cone so the tabs line up with the bolts and tighten completely, refer to Figure B. Once the (2) bolts are tight, tighten the Jam Nuts against the threaded boss, refer to Figure C. See Figure D for proper Blower Cone installation.

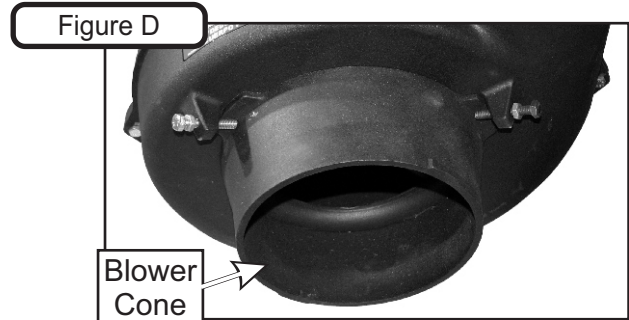
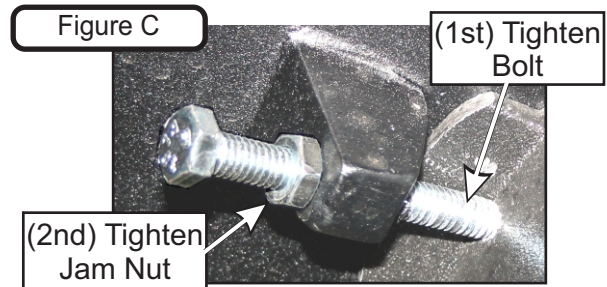
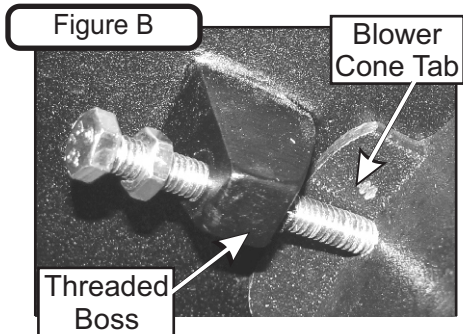
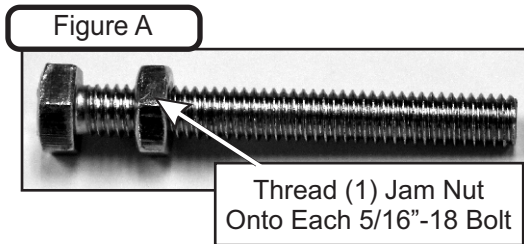

Boot Kit Installation

Secure the boot plate P#(B1815) to the aluminum boot P#(E1126) using (2) 3/8"-16 x 1" carriage bolts P#(K1182) and (2) 3/8"-16 nylon flange locknuts P#(K2038). Insert the bolts from the inside so that the threads are on top of the boot. This will prevent grass clippings from collecting on the bolt threads. Leave the hardware loose until the boot assembly has been attached to the mower deck. Lift the grass deflector and slide the boot plate under the grass deflector rod. Close any gaps between the boot and the mower deck by adjusting the position on the boot in the boot plate slots. Tighten all hardware at this time. Refer to Figure E.

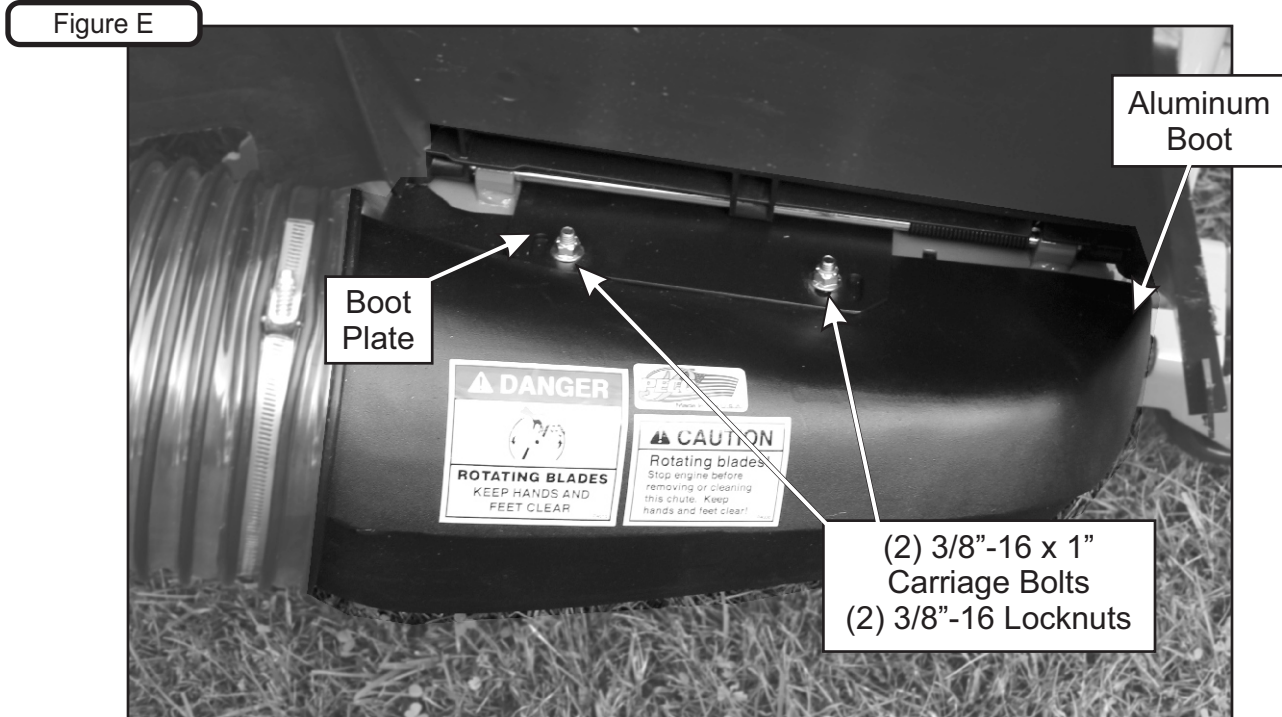

Length Of Hose Adjustment

The hoses in the following steps must be cut to fit your machine. Do not cut the hoses until you have tried to fit them on your machine. Remember that the hoses need to be long enough to allow for the opening and closing of the collection system as well as allowing ample clamping surface between each component.

Upper Hose Installation

Slide a Hose Clamp P#(J0070) over both ends of the 7" Upper Hose. Secure one end of the Upper Hose to the Inlet and Blower Outlet. Fasten the Hose by tightening

Lower Hose To Blower Cone Installation

Slide a Hose Clamp, P#(J0090) over both ends of the 9" Lower Hose. Secure one end of the Lower Hose to the Blower Cone. Fasten the Hose by tightening the Hose Clamp.

Lower Hose To Boot Installation

Take the unattached end of the Lower Hose and secure it to the circular end of the Boot and fasten by tightening the Hose Clamp.

Tip: Before securing Hose Clamp fully, rotate Lower Hose counter-clockwise (away from yourself) approximately 1" to aid in retaining Boot to mower deck.

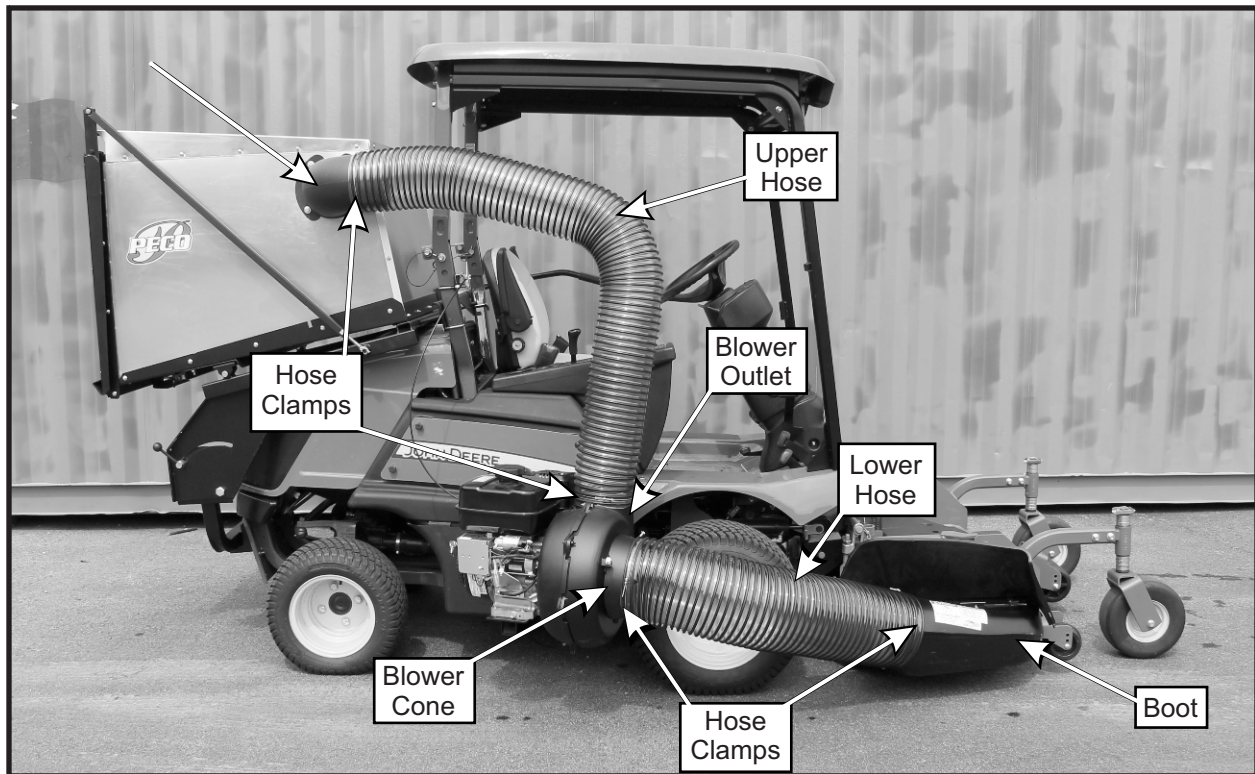

Impeller Blade Removal/Replacement

To Remove: First remove the 7/16"-20 x 1" HHCS P#(K1394) (#1), 7/16" Double Indented Washer P#(K0278) (#2) and (2) 3/8" x 15/16" Bushing P#(S0159) (#4) from the Taper-Lock Bushing P#(S4302) (#5). Next remove the (2) 1/4"-20 x 1" HHCS (#3) and place them into the threaded holes of the Taper-Lock Bushing (#5). Gradually thread each bolt evenly into the Taper-Lock Bushing, forcing the blade to break-away from the Taper-Lock Bushing. If the Impeller will not move, carefully hit the base of the Impeller, between each vein, with a hammer, then try again.

To Replace: Firstly, apply anti-seize to the 7/16"-20 x 1" HHCS (#1). Next, place the Impeller Blade over the engine shaft. Slide the Taper-Lock Bushing (#5) on to the engine shaft and into the Impeller Blade, aligning the **non-threaded** holes of the Taper-Lock Bushing to the threaded holes of the Impeller Blade. Fasten by using (2) 1/4"-20 x 1" HHCS (#3), (2) 3/8" x 15/16" Bushing P#(S0159) (#4), (1) 7/16" Double Indented Washer (#2), and (1) 7/16"-20 x 1" HHCS (#1).

Torque to the proper specifications in the torque chart on the back of this manual. Next, rotate the Impeller Blade to ensure that the blade is clear of contact on all sides of the blower housing.

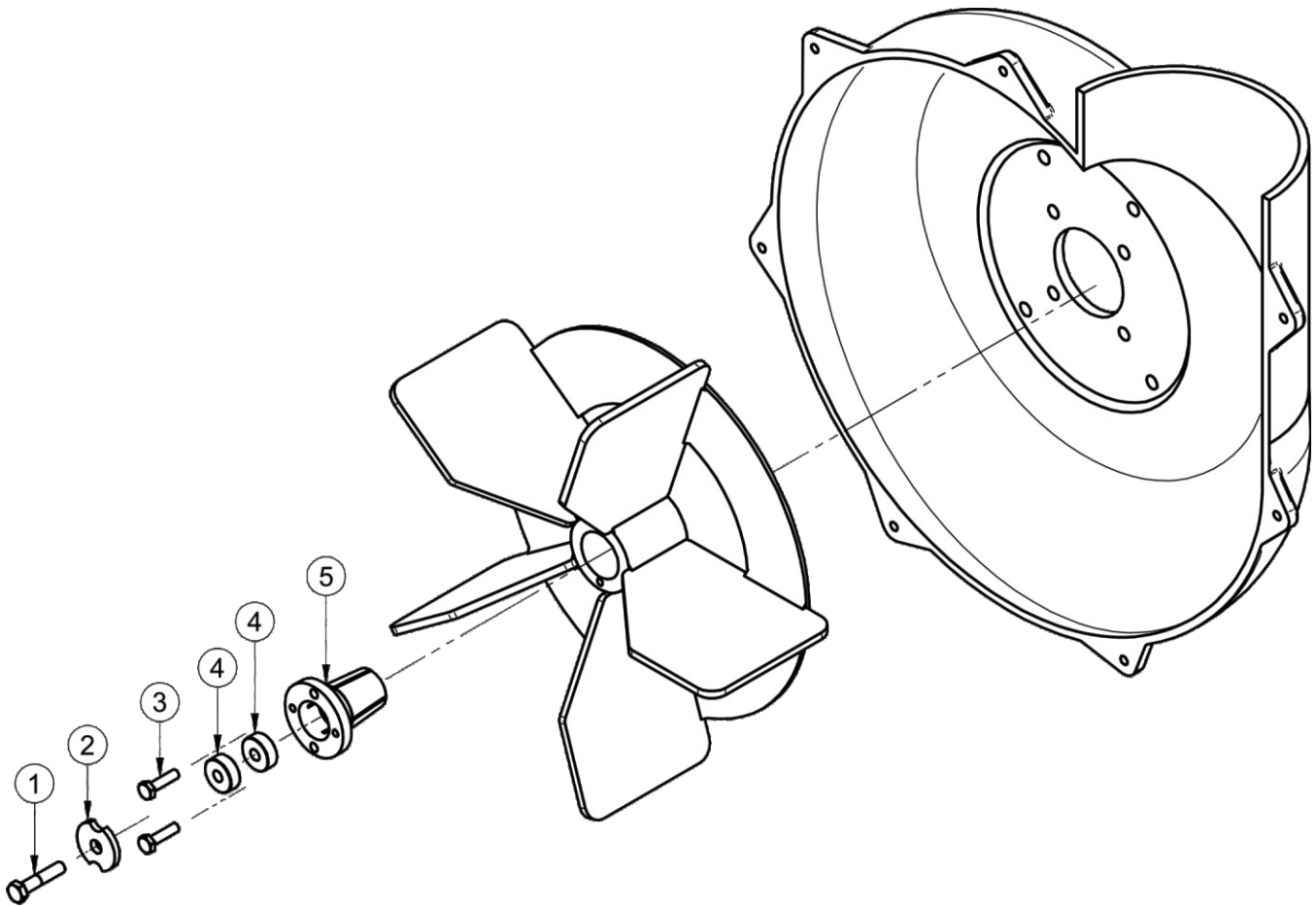

A2046_01 - Pro 24 Box Assembly

Bottom Explode

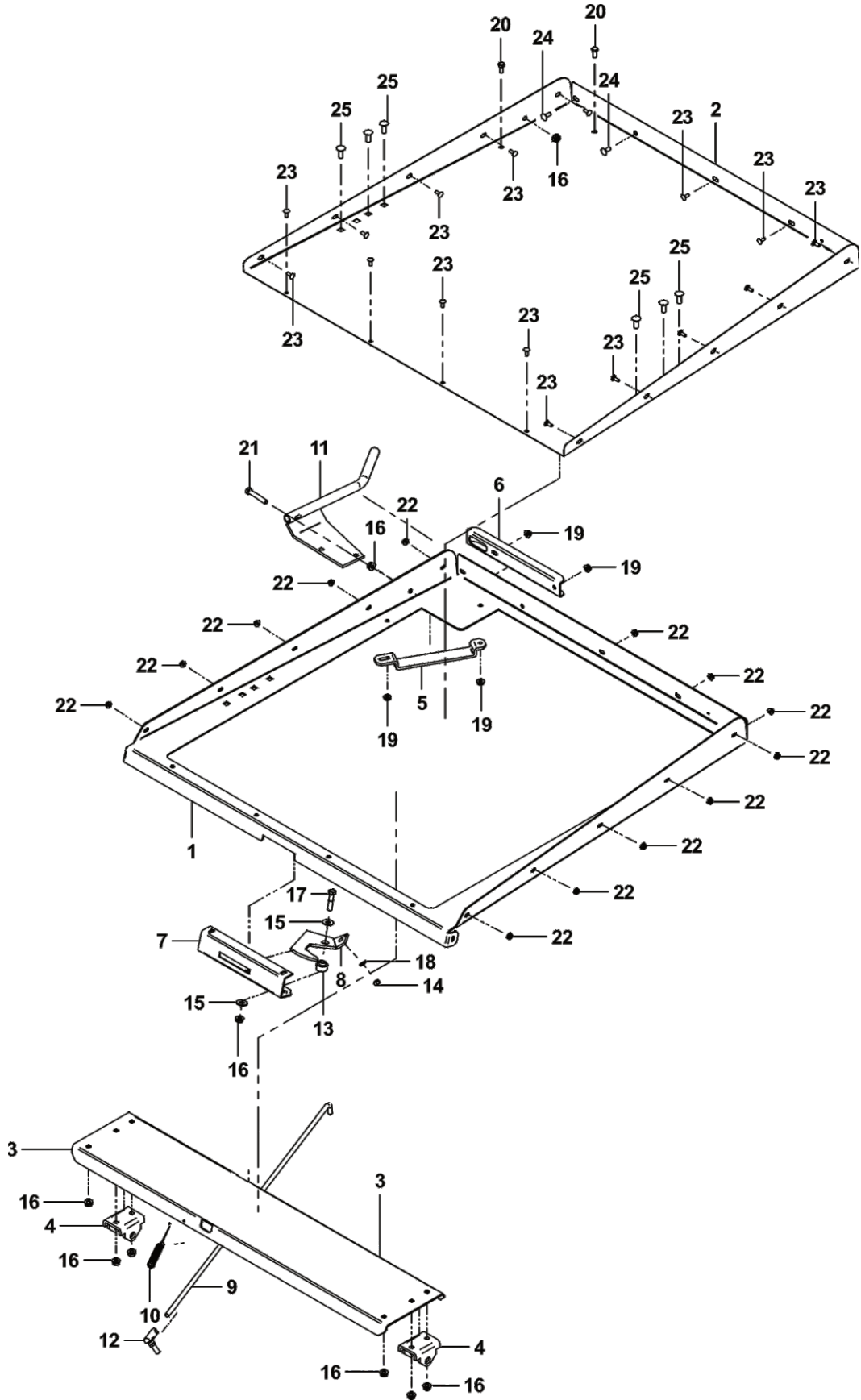

A2046_01 - Pro 24 Box Assembly**Bottom Exploded Parts List**

Item #	Part #	Desc.	Qty.
1	B1833	Box Base Frame	1
2	C0042	Box Bottom	1
3	B1835	PIVOT PL.	1
4	B1832	BOX PIVOT BRKT.	2
5	B0006	HANDLE SLIDE BRKT.	1
6	B1730	Latch Handle Mount Bracket	1
7	B1805	LATCH HOOK PIVOT PL.	1
8	B1804	LATCH HOOK	1
9	B1840	Latch Rod	1
10	J0255	Extension Spring	1
11	A2334	P24 Box Base Handle	1
12	J0234	3/8"-24 Ball Joint	1
13	S0155	Pivot Bushing	1
14	K1410	3/8"-24 Hex Nut	1
15	K0047	Flat Washer 3/8" / 1.00 OD x .446 ID x .075 T	2
16	K1215	Flange Nut 3/8"-16	9
17	K1462	HHCS 3/8"-16 x 1-3/4" GR8	1
18	K0048	Lock Washer 3/8"	1
19	K1178	Flange Nut 5/16"-18	4
20	K1153	HHCS 5/16"-18 x 3/4"	2
21	K1196	3/8"-16 x 2 1/4" HHCS	1
22	K1126	Flange Nut 1/4"-20	17
23	K1010	1/4"-20 x 5/8" Carriage Bolt	17
24	K1142	5/16"-18 x 3/4" Carriage Bolt	2
25	K1182	Carriage Bolt 3/8"-16 x 1"	6

A2046_01 - Pro 24 Box Assembly
Back, Sides & Top Explode

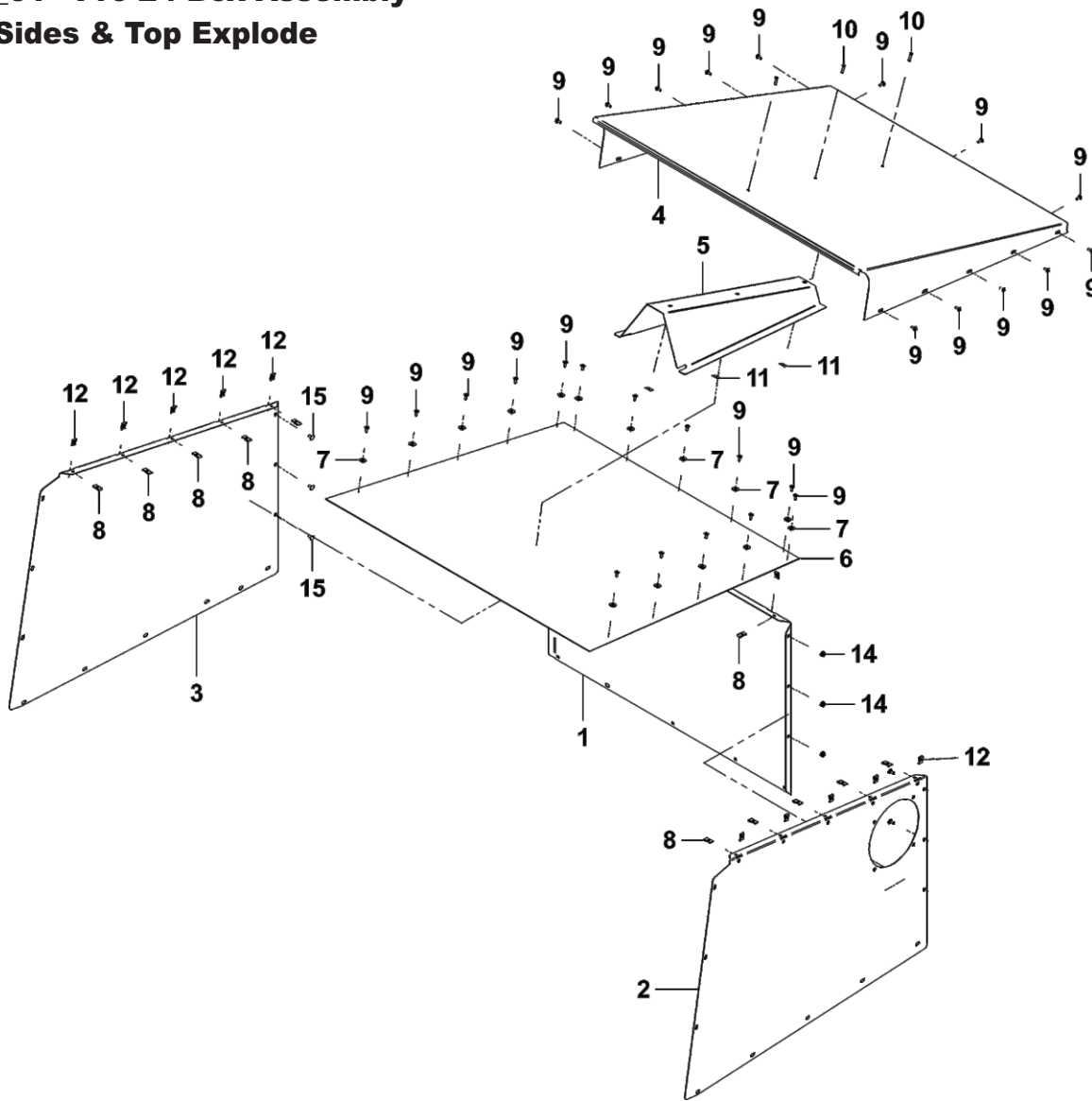

Item #	Part #	Desc.	Qty.
1	C0045	Box Back	1
2	C0043_01	Box Right Side	1
3	C0044	Box Left Side	1
4	C0041_01	Box Top	1
5	C0039_01	Screen Support	1
6	B8001	SCREEN	1
7	K0037	Flat Washer / 1/4" (.75 OD x .312 ID x .060 T)	15
8	K0068	Tinnerman Clip / Large	15
9	K1096	#10-12 x 1/2" Tinnerman Screw	28
10	K1092	#10-12 x 3/4" Blunt Tip SMS	3
11	K0029	#10-12 Flat Tinnerman Nut 3/4" x 1/2"	3
12	K0028	Tinnerman Clip / Small	13
13*	K0044	I/T Tooth Lock Washer 5/16"	6
14	K1126	Flange Nut 1/4"-20	6
15	K1005	1/4"-20 x 1/2" Carriage Bolt	6

**A2046_01 - Pro 24 Box Assembly
Door & Door Frame Explode**

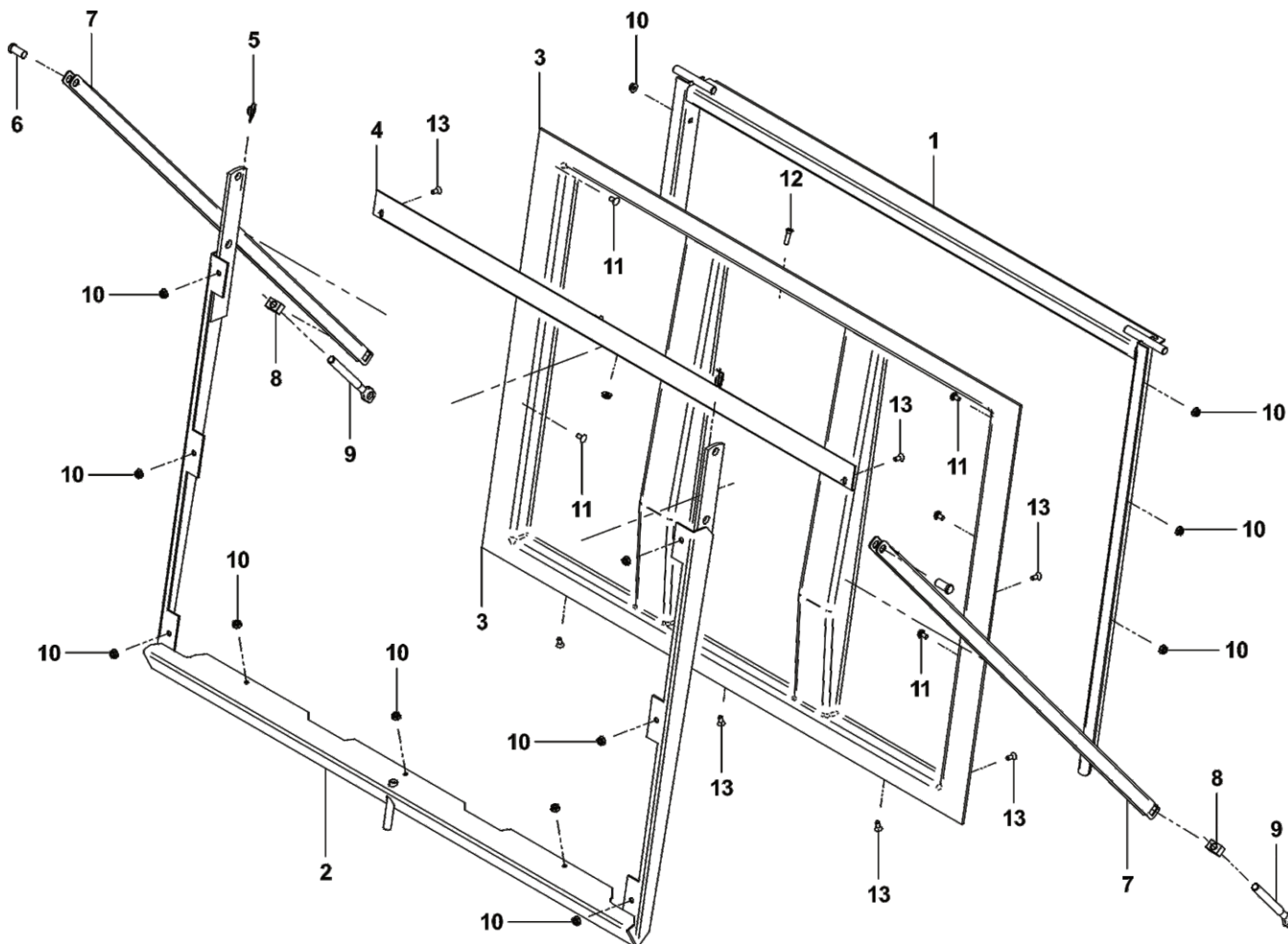

Item #	Part #	Desc.	Qty.
1	A0331	Box Opening Frame Assy.	1
2	A0330	Door Frame Assy.	1
3	V1154	DOOR	1
4	B1834	UPPER DOOR MEMBER	1
5	K1437	Rue Ring Cotter Pin	2
6	K1418	Linkage Pin	2
7	B1596	DOOR LINKAGE	2
8	K1422	Door Linkage Nut 1/2"-13	2
9	K1435	Adjustment Screw	2
10	K1126	Flange Nut 1/4"-20	16
11	K1005	1/4"-20 x 1/2" Carriage Bolt	6
12	K1136	Flat Head MS Screw 1/4"-20 x 1"	1
13	K1131	1/4"-20 x 5/8" Phillips Flat Head Machine Screw	9

Unit Model #: 06742408

Mower: John Deere

Owner's Manual: Q0498

Mower Type: TerrainCut 1550, 1570, 1575 (Cab)

Deck Size: 60" & 72"

Vac Type: Pro24 DFS

Drive Type: 14HP Briggs & Stratton Vanguard

Deck Type:

Revision #: 2 - Updated Models Fit - KR 2022

Fits Year(s): 2015 - Newer

A2346 Unit Assembly

- (1) C0074 Inlet Ring (Split Cut)
- (1) C0088 Debris Deflector
- (1) V0025C Plastic Inlet

- A1767 Boot Kit
 - (1) B1815 Boot Plate
 - (1) E1126 Boot
 - (1) HB0412 Boot Kit HW Bag

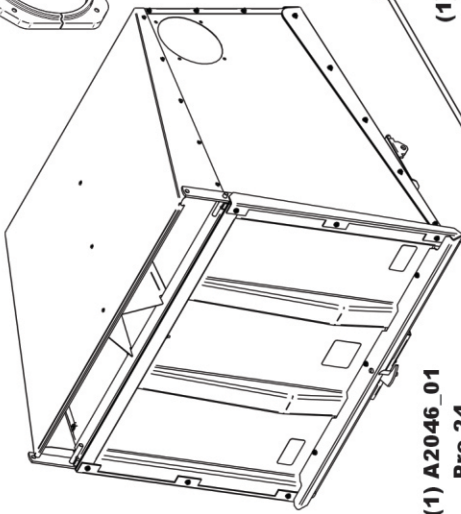
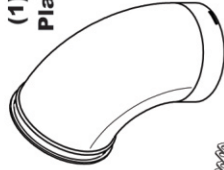

- (1) A2046_01 Pro 24 Box Assy.

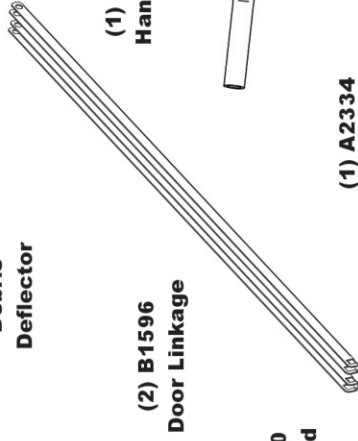

- (2) B1596 Door Linkage

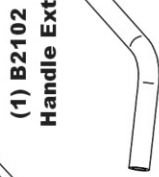

- (1) B2102 Handle Ext

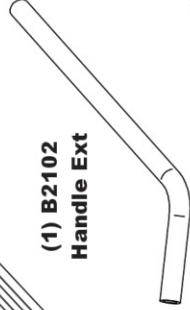

- (1) B0222_01 Left Leg Box Support

- (1) B1840 Catch Rod

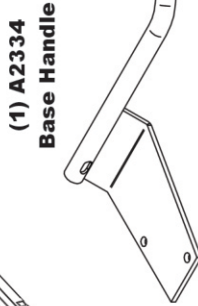

- (1) A2334 Base Handle

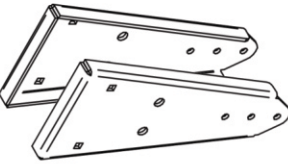

- (2) B2105 Frame Side Bracket

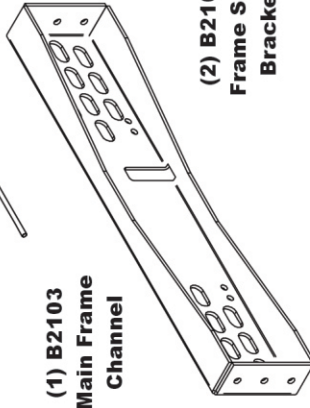

- (1) F0070-80 7" x 80" Upper Hose

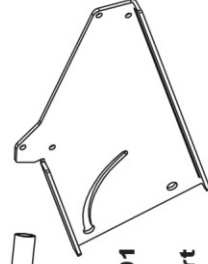

- (1) B0209_01 Right Leg Box Support



- (2) J0070 7" Hose Clamps



- (1) E6012 9" Blower Cone



- (2) J0090 9" Hose Clamps

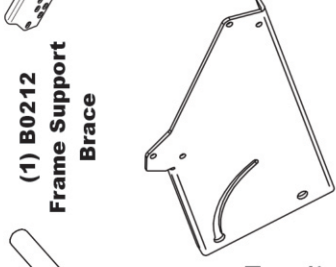

- (1) B0212 Frame Support Brace



- (1) HB0316 Mount Kit HW Bag

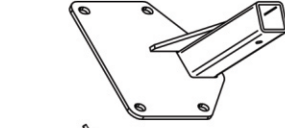

- (1) A2440 Inner Engine Mnt Weldment

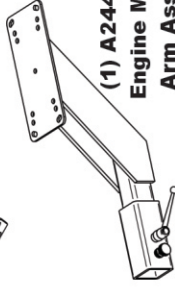

- (1) A2445 Engine Mint Arm Assy

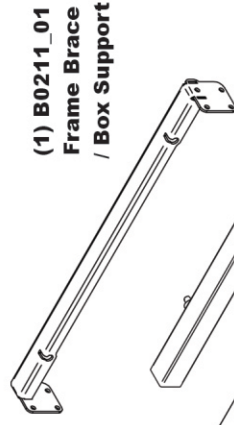

- (1) A2340 Left Tube Assembly

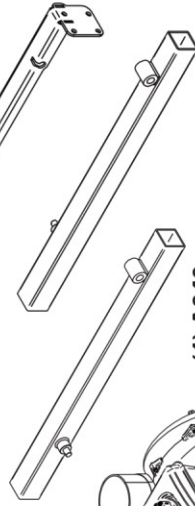

- (1) A640 14 HP B&S Eng/Blwr/Blade Assembly

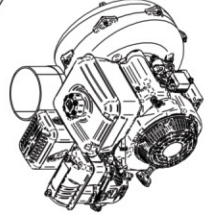

- (1) A2341 Right Tube Assembly

- (1) B0211_01 Frame Brace / Box Support

Unit Model #: 06742410

Mower: John Deere

Owner's Manual: Q0498

Mower Type: TerrainCut 1550, 1570, 1575 (Cab)

Deck Size: 60" & 72"

Vac Type: Pro24 DFS

Deck Type:

Drive Type: 7HP Yanmar Diesel Engine

Revision #: 2 - Updated Models Fit - KR Sep 2022

Fits Year(s): 2015 - Newer

A2350 Unit Assembly

(1) V0025C
Plastic Inlet

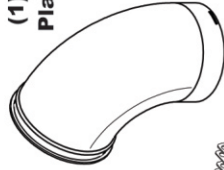

(1) C0074
Inlet Ring
(Split Cut)



(1) C0088
Debris
Deflector



(2) B1596
Door Linkage

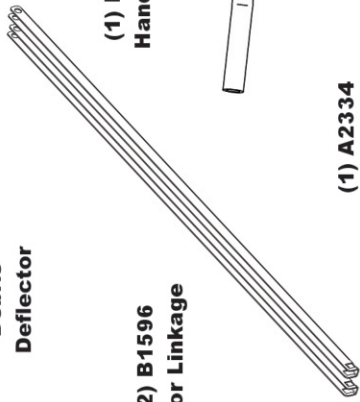

(1) B1840
Catch Rod

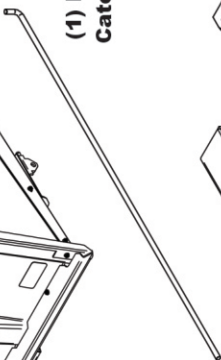

(1) A2046_01
Pro 24
Box Assy.

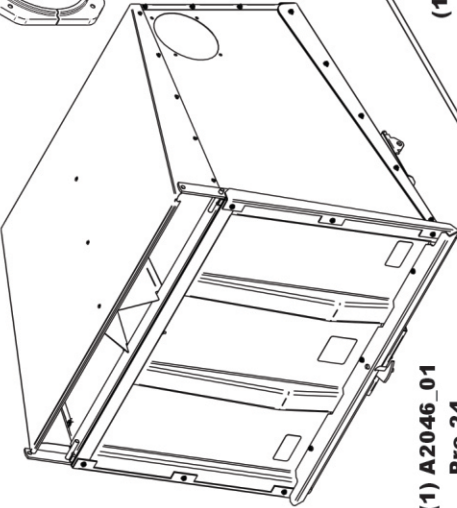

(1) B2103
Main Frame
Channel

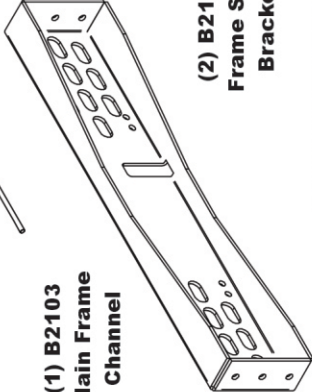

(2) B2105
Frame Side
Bracket

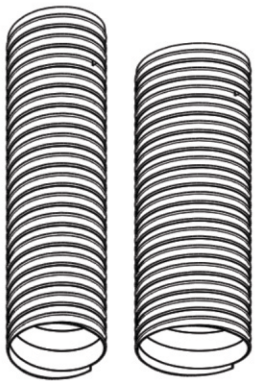

(1) F0070-80
7" x 80"
Upper Hose

(1) F0090-46
9" x 46"
Lower Hose

A1767 Boot Kit

(1) E1126
Boot

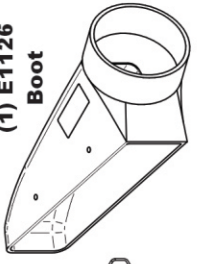

(1) B1815
Boot Plate

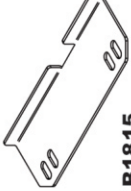

(1) V0025C
Plastic Inlet

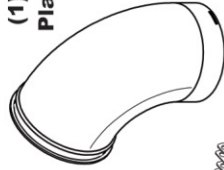

(1) C0088
Debris
Deflector



(2) B1596
Door Linkage

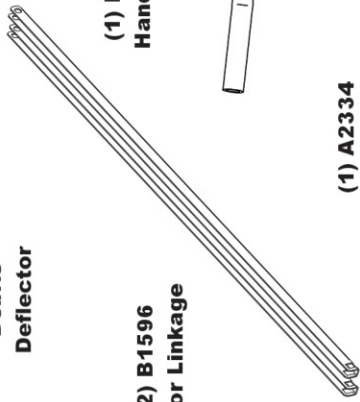

(1) B1840
Catch Rod

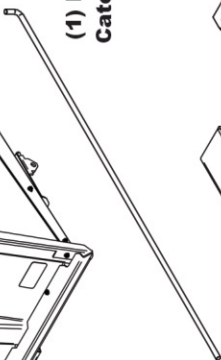

(1) A2046_01
Pro 24
Box Assy.

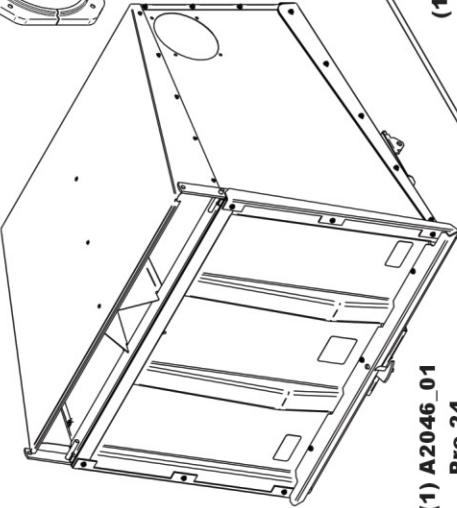

(1) B2103
Main Frame
Channel

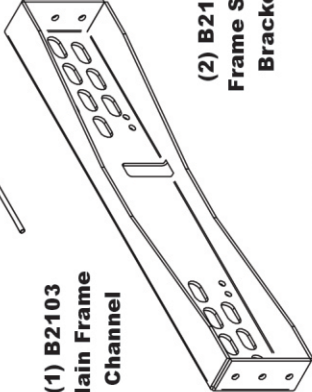

(2) B2105
Frame Side
Bracket

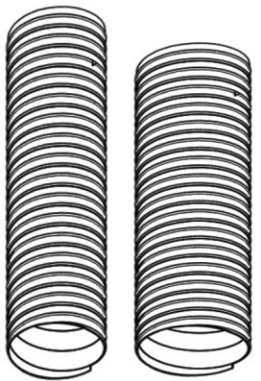

(1) F0070-80
7" x 80"
Upper Hose

(1) F0090-46
9" x 46"
Lower Hose

(1) V0025C
Plastic Inlet

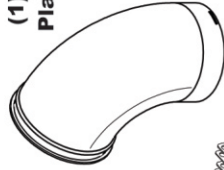

(1) C0088
Debris
Deflector



(2) B1596
Door Linkage

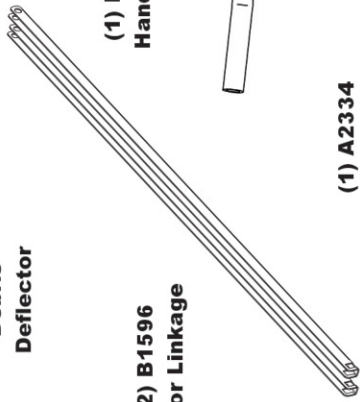

(1) B1840
Catch Rod

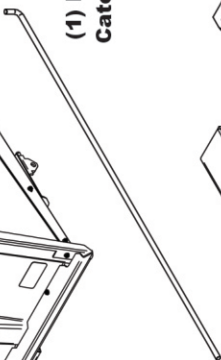

(1) A2046_01
Pro 24
Box Assy.

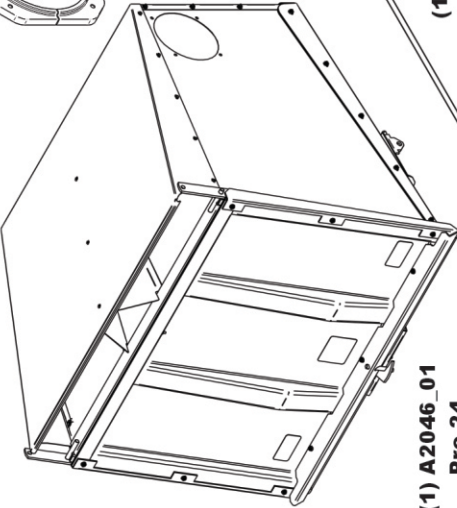

(1) B2103
Main Frame
Channel

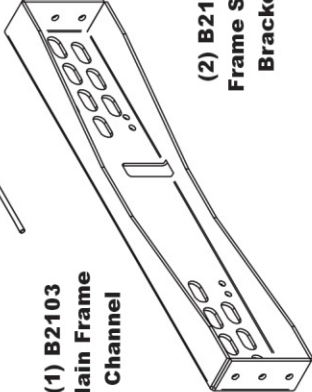

(2) B2105
Frame Side
Bracket

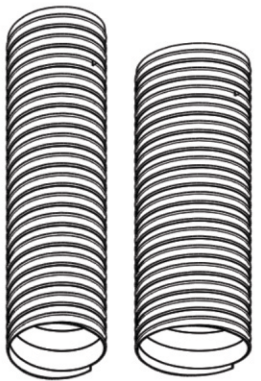

(1) F0070-80
7" x 80"
Upper Hose

(1) F0090-46
9" x 46"
Lower Hose

A1767 Boot Kit

(1) E1126
Boot

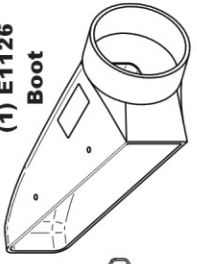

(1) B1815
Boot Plate

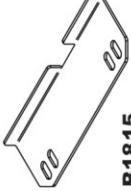

(1) V0025C
Plastic Inlet

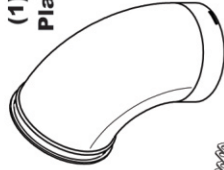

(1) C0088
Debris
Deflector



(2) B1596
Door Linkage

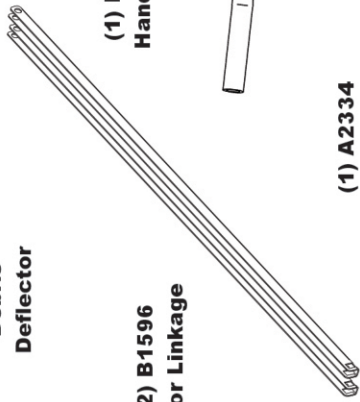

(1) B1840
Catch Rod

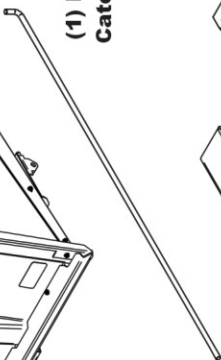

(1) A2046_01
Pro 24
Box Assy.

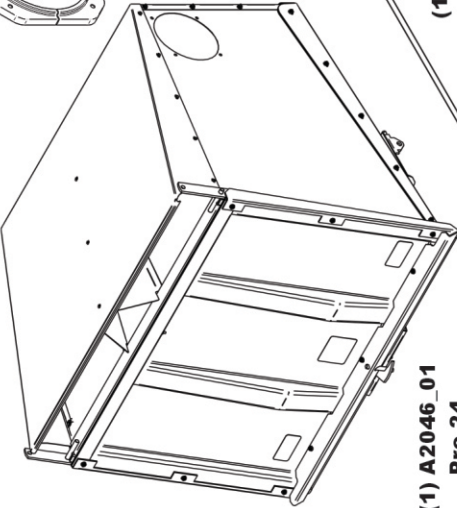

(1) B2103
Main Frame
Channel

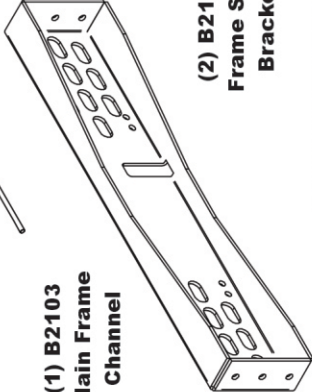

(2) B2105
Frame Side
Bracket

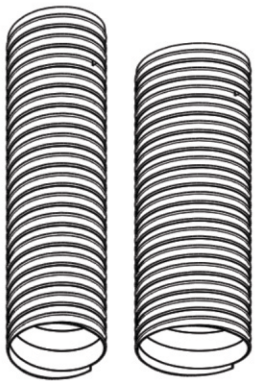

(1) F0070-80
7" x 80"
Upper Hose

(1) F0090-46
9" x 46"
Lower Hose

(1) V0025C
Plastic Inlet

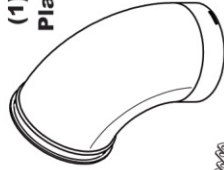

(1) C0088
Debris
Deflector



(2) B1596
Door Linkage

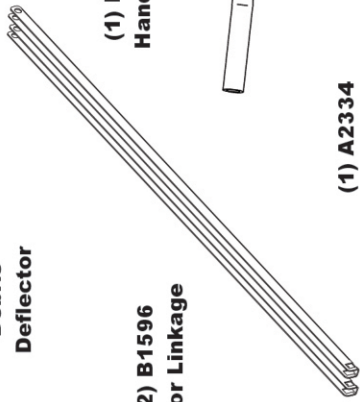

(1) B1840
Catch Rod

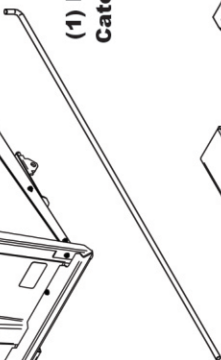

(1) A2046_01
Pro 24
Box Assy.

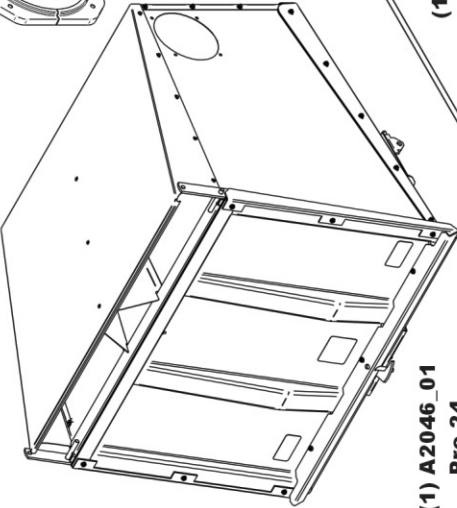

(1) B2103
Main Frame
Channel

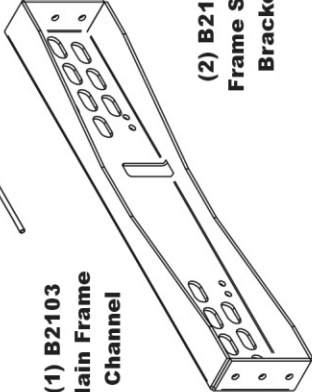

(2) B2105
Frame Side
Bracket

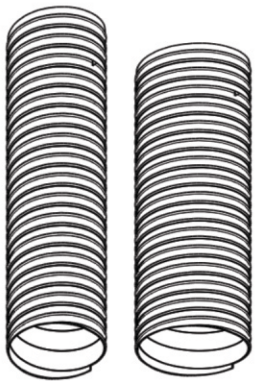

(1) F0070-80
7" x 80"
Upper Hose

(1) F0090-46
9" x 46"
Lower Hose

A1767 Boot Kit

(1) E1126
Boot

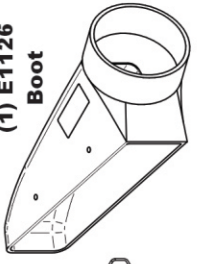

(1) B1815
Boot Plate

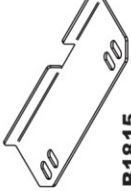

(1) V0025C
Plastic Inlet

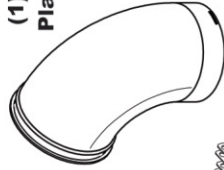

(1) C0088
Debris
Deflector



(2) B1596
Door Linkage

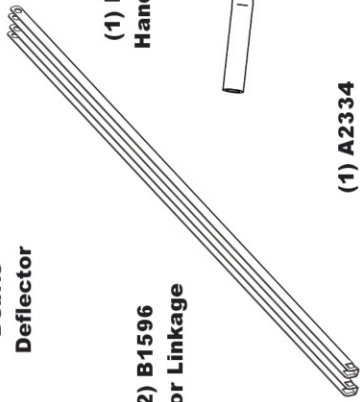

(1) B1840
Catch Rod

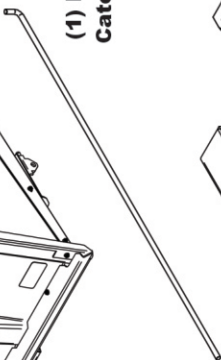

(1) A2046_01
Pro 24
Box Assy.

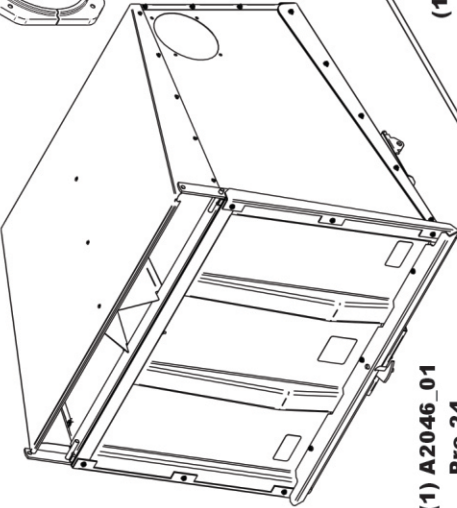

(1) B2103
Main Frame
Channel

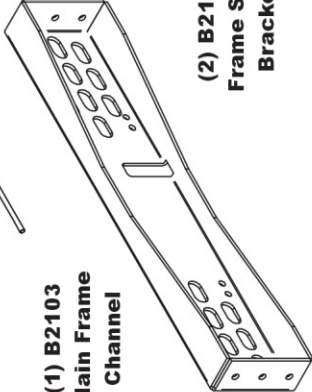

(2) B2105
Frame Side
Bracket

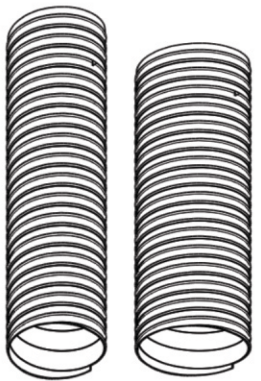

(1) F0070-80
7" x 80"
Upper Hose

(1) F0090-46
9" x 46"
Lower Hose

(1) V0025C
Plastic Inlet

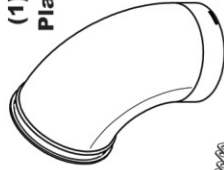

(1) C0088
Debris
Deflector



(2) B1596
Door Linkage

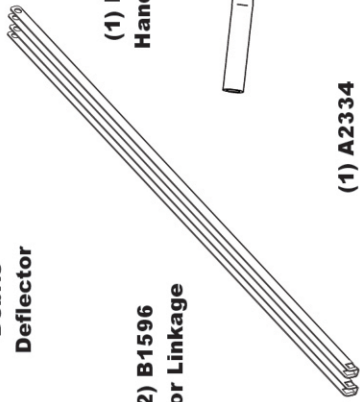

(1) B1840
Catch Rod

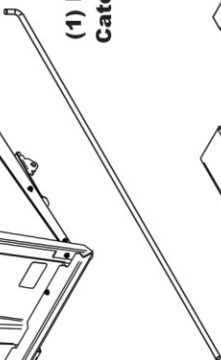

(1) A2046_01
Pro 24
Box Assy.

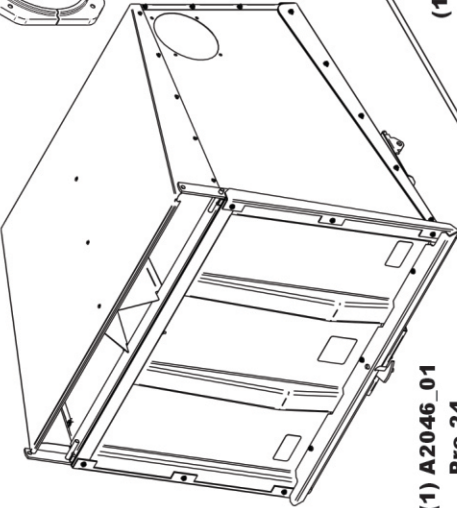

(1) B2103
Main Frame
Channel

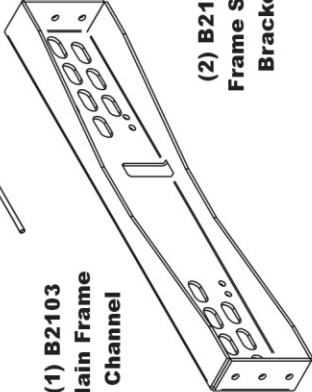

(2) B2105
Frame Side
Bracket

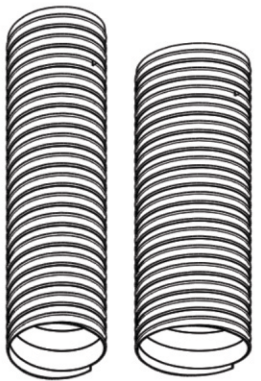

(1) F0070-80
7" x 80"
Upper Hose

(1) F0090-46
9" x 46"
Lower Hose

A1767 Boot Kit

(1) E1126
Boot

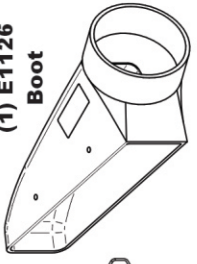

(1) B1815
Boot Plate

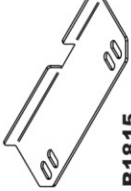

(1) V0025C
Plastic Inlet

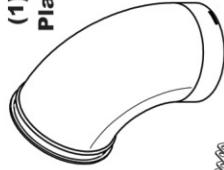

(1) C0088
Debris
Deflector



(2) B1596
Door Linkage

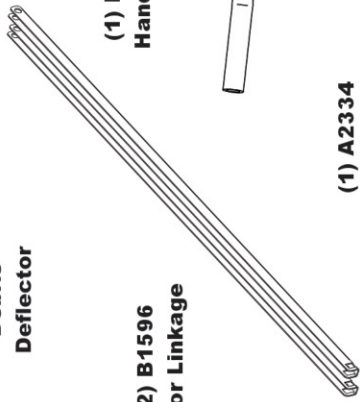

(1) B1840
Catch Rod

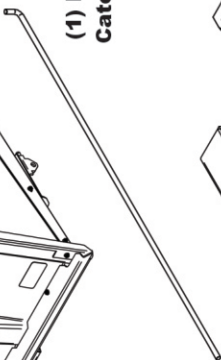

(1) A2046_01
Pro 24
Box Assy.

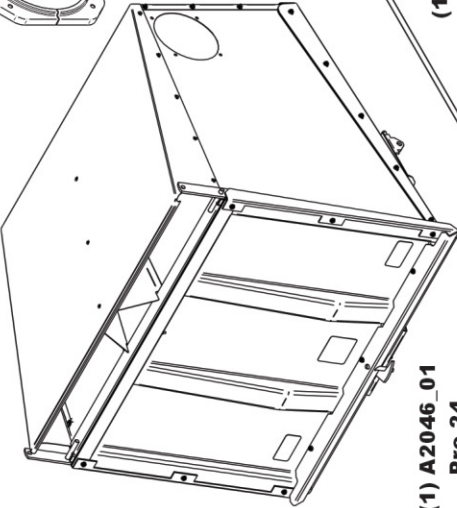

(1) B2103
Main Frame
Channel

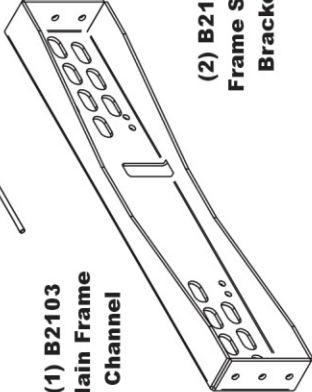

(2) B2105
Frame Side
Bracket

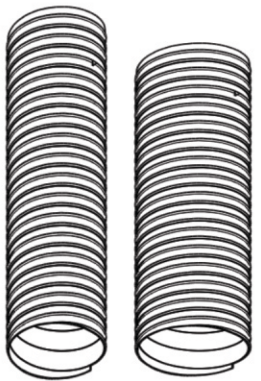

(1) F0070-80
7" x 80"
Upper Hose

(1) F0090-46
9" x 46"
Lower Hose

(1) V0025C
Plastic Inlet

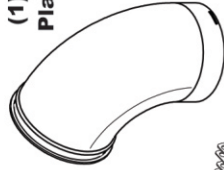

(1) C0088
Debris
Deflector



(2) B1596
Door Linkage

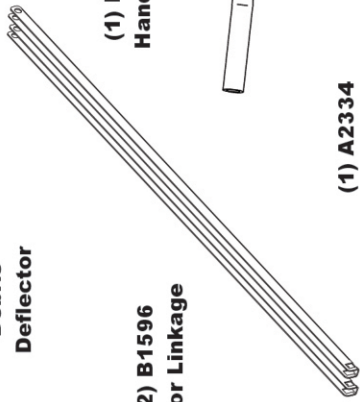

(1) B1840
Catch Rod

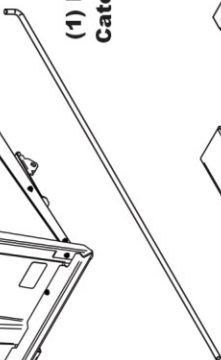

(1) A2046_01
Pro 24
Box Assy.

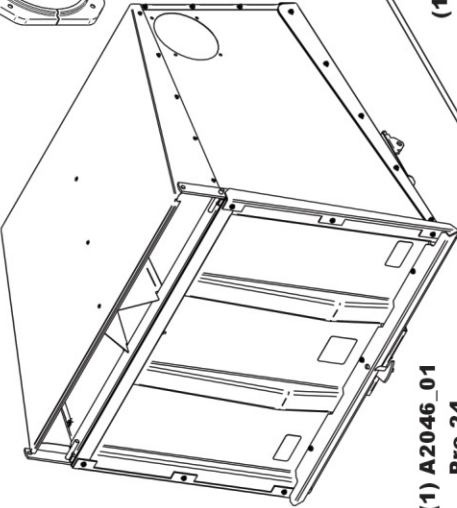

(1) B2103
Main Frame
Channel

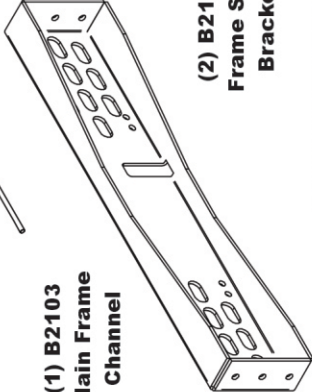

(2) B2105
Frame Side
Bracket

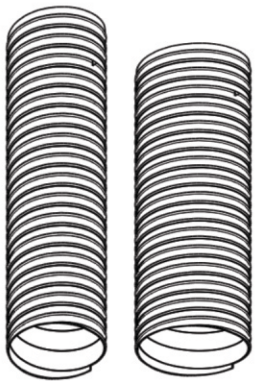

(1) F0070-80
7" x 80"
Upper Hose

(1) F0090-46
9" x 46"
Lower Hose

A1767 Boot Kit

(1) E1126
Boot

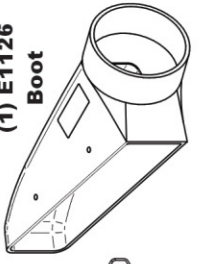

(1) B1815
Boot Plate

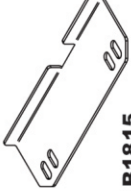

(1) V0025C
Plastic Inlet

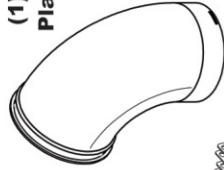

(1) C0088
Debris
Deflector



(2) B1596
Door Linkage

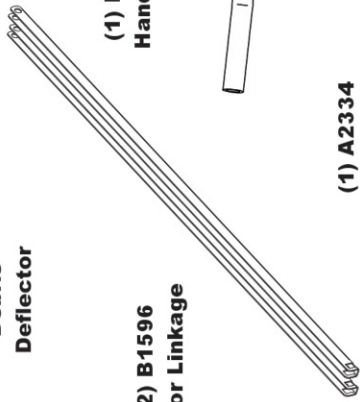

(1) B1840
Catch Rod

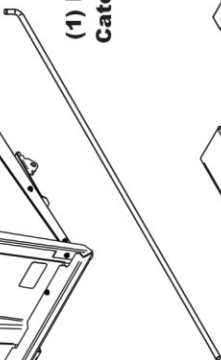

(1) A2046_01
Pro 24
Box Assy.

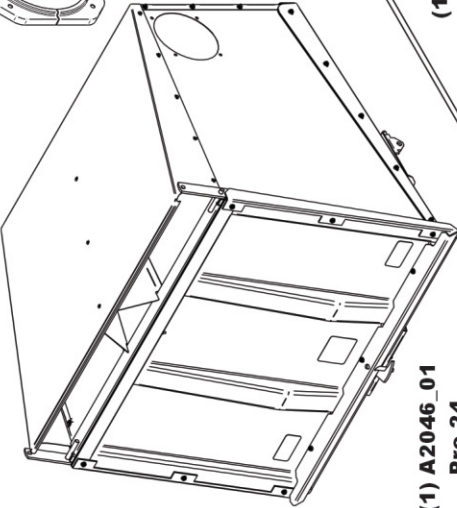

(1) B2103
Main Frame
Channel

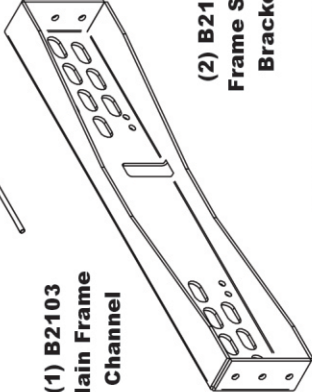

(2) B2105
Frame Side
Bracket

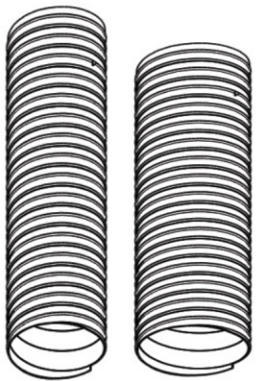

(1) F0070-80
7" x 80"
Upper Hose

(1) F0090-46
9" x 46"
Lower Hose

(1) V0025C
Plastic Inlet

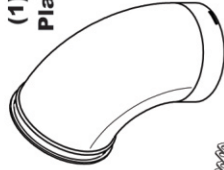

(1) C0088
Debris
Deflector



(2) B1596
Door Linkage

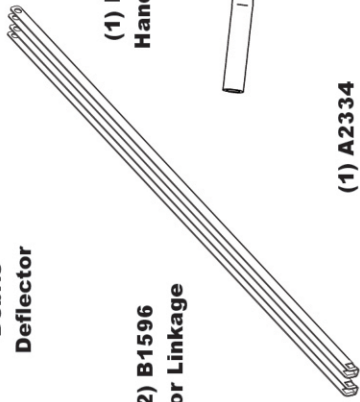

(1) B1840
Catch Rod

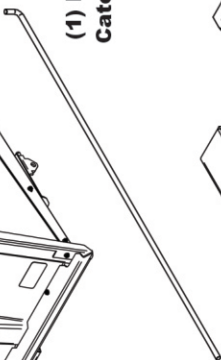

(1) A2046_01
Pro 24
Box Assy.

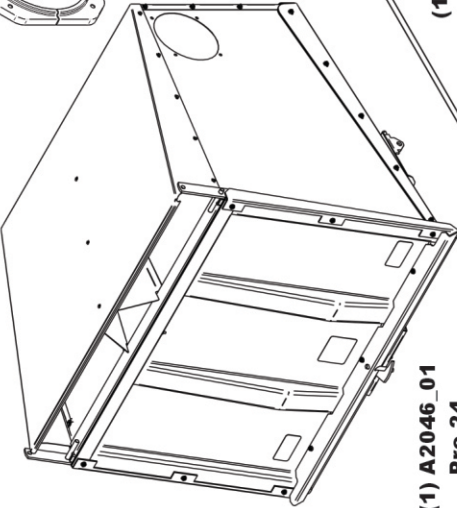

(1) B2103
Main Frame
Channel

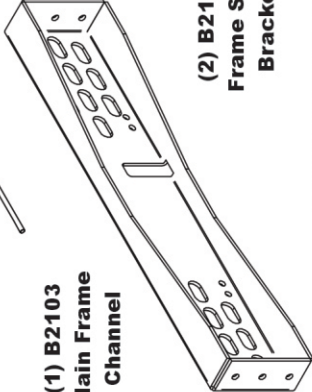

(2) B2105
Frame Side
Bracket

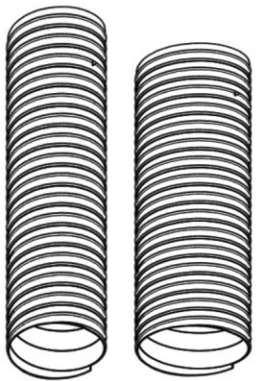

(1) F0070-80
7" x 80"
Upper Hose

(1) F0090-46
9" x 46"
Lower Hose

A1767 Boot Kit

(1) E1126
Boot

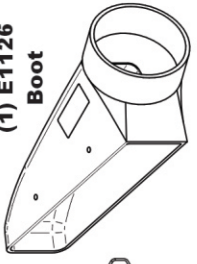

(1) B1815
Boot Plate

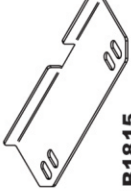

(1) V0025C
Plastic Inlet

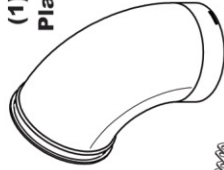

(1) C0088
Debris
Deflector



(2) B1596
Door Linkage

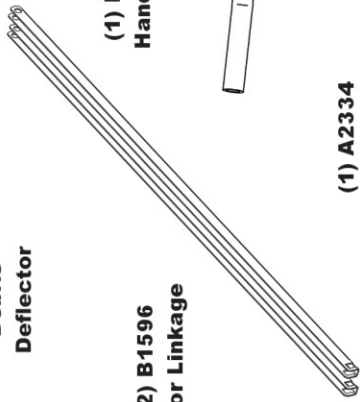

(1) B1840
Catch Rod

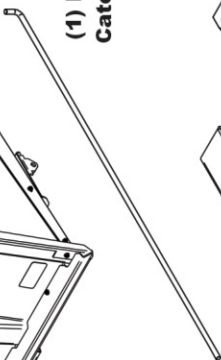

(1) A2046_01
Pro 24
Box Assy.

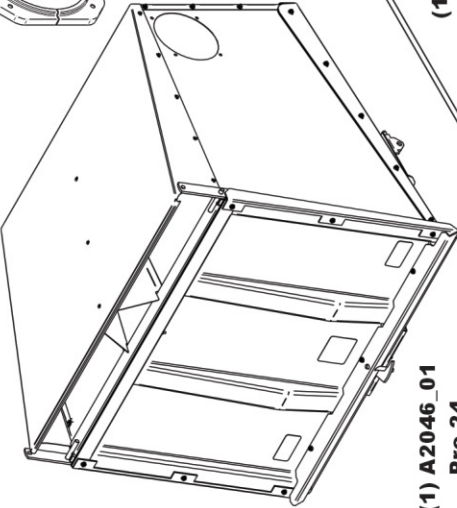

(1) B2103
Main Frame
Channel

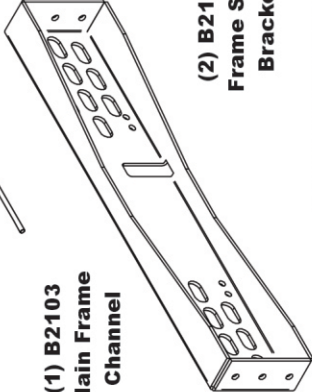

(2) B2105
Frame Side
Bracket

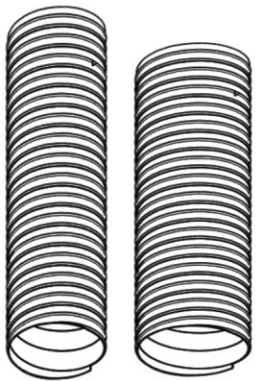

(1) F0070-80
7" x 80"
Upper Hose

(1) F0090-46
9" x 46"
Lower Hose

(1) V0025C
Plastic Inlet

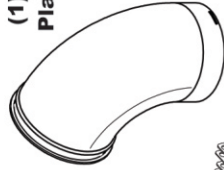

(1) C0088
Debris
Deflector



(2) B1596
Door Linkage

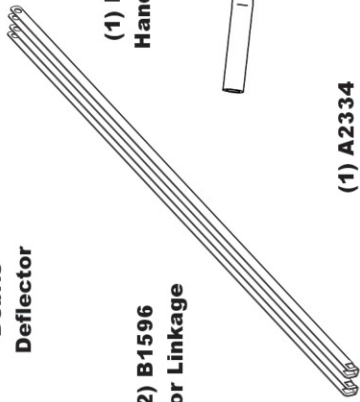

(1) B1840
Catch Rod

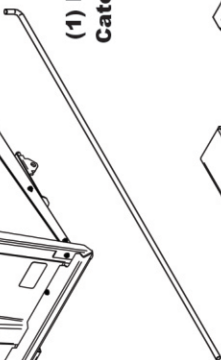

(1) A2046_01
Pro 24
Box Assy.

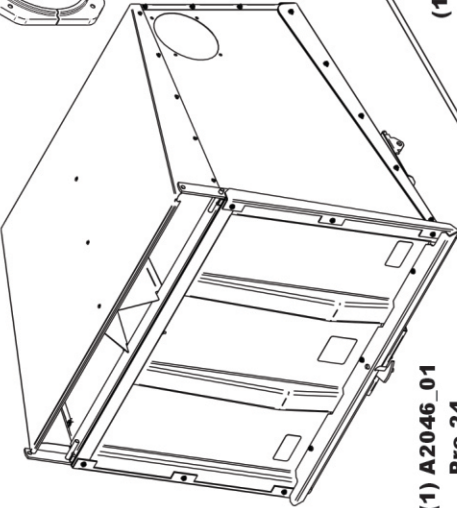

(1) B2103
Main Frame
Channel

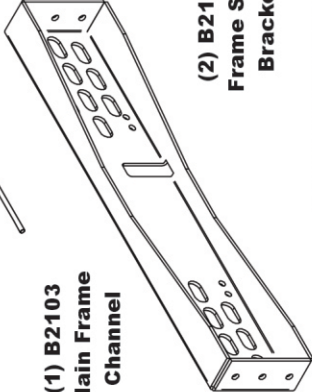

(2) B2105
Frame Side
Bracket

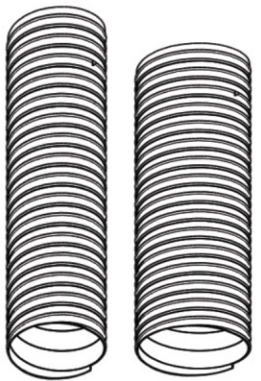

(1) F0070-80
7" x 80"
Upper Hose

(1) F0090-46
9" x 46"
Lower Hose

A1767 Boot Kit

(1) E1126
Boot

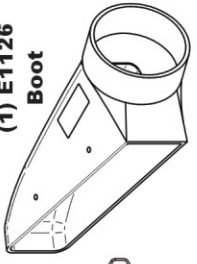

(1) B1815
Boot Plate

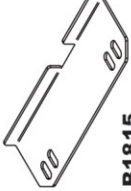

(1) V0025C
Plastic Inlet

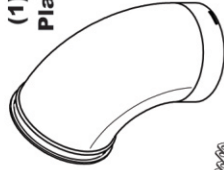

(1) C0088
Debris
Deflector



(2) B1596
Door Linkage

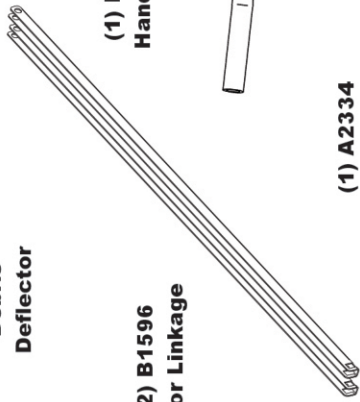

SAFETY DECALS

To promote safe operation, New PECO, Inc. supplies safety decals on all products manufactured. Damage can occur to safety decals either through shipment, use or reconditioning. Contact your local Service Center for replacement decals.



Part# R1070
PECO Logo

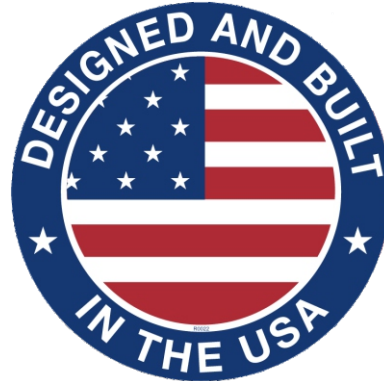

Part# R0022
Designed & Built
In The USA



Part #: R1053
Caution - Keep Hands
& Body Clear

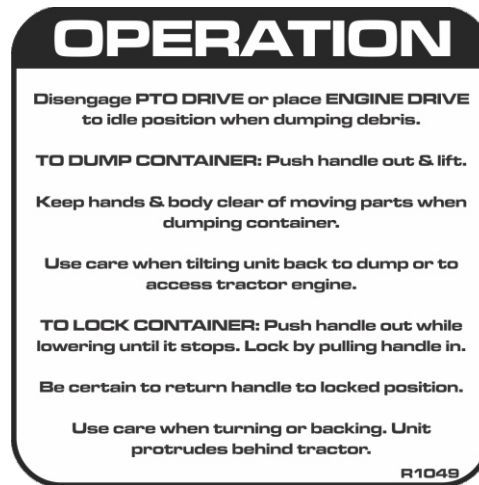

Part #: R1049
Operation Decal

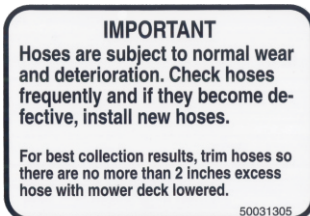

Part #: R1054
Important - Hose Wear

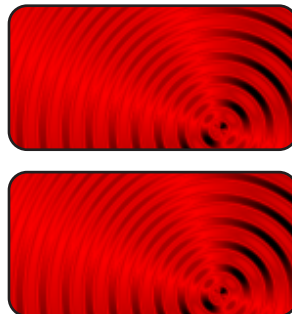

Part #: R1057 - (2)
Red Reflectors



Part #: R1069
Warning - Turn Off Blower



Part #: R1051
Warning - Hearing Protection



Part # R0025
Danger - Rotating
Blades

SECTION III OPERATING INSTRUCTIONS

General Safety

Only qualified people familiar with this operator's manual and the mower's operator's manual should operate this machine.

Operation & Tips On Mowing

- A. Perform BEFORE EACH USE maintenance.
- B. Start the engine/blower/blade assembly.
- C. Start mower.
- D. With the mower at high idle speed, engage the mower deck.
- E. Proceed to operate the control levers of the mower.

Note: If the collection system does not appear to be collecting the grass clippings; disengage the deck, and blower, engage the parking brake and turn the mower off. Check the upper hose, lower hose, top screen and boot for clogs.

To obtain the maximum effectiveness from your collection system the tips listed below should be followed:

- * Watch your speed- Normal conditions will allow a speed of up to approximately 5 mph, but thick, heavy damp conditions will require reduced ground speed.
- * Mow with sharp blades- A sharp blade cuts cleaner.
- * Wet grass and leaves will decrease effectiveness and will increase horsepower requirements.
- * Mow at higher cutting heights- Remove and mulch no more than 2" of grass length with each mowing. (Experts recommend not cutting off more than 1/3 of the grass blade length at any given time.)
- * Mow twice, at different height settings, (high, then low), if grass is extra tall.
- * Remember that horsepower requirements will vary with the mowing conditions such as type and height of turf grass, moisture content, amount of leaves, whether the terrain is flat or hilly, etc.

Unloading The Collection System

Note: Press the tab, located behind the operator's left side, downward to feel if the collection system is full. If the container is full there will be resistance when depressing the tab.

- A. Stop the forward movement of the mower.
- B. Disengage the mower deck.
- C. Using the throttle cable slow the engine down to idle.
- D. Push the dump handle, on the left of the operator, away from the unit. While holding the handle pushed away, move the handle upward. The container door will swing upward and the container will rotate downward. The container will release its contents.
- E. Once the contents of the container have fallen out, the container is ready to move back into its normal operating position. With the handle in the 'away' position, pull the handle downward until it stops. Move the handle towards the center of the mower. This motion will allow the latch to lock back into collection position.

Note: If you do not hold the handle away from the mower as you pull the handle downward, the latch will not lock and the container can unexpectedly release the contents collected.

SECTION IV MAINTENANCE

Maintenance Checklist

Before each use:

1. Check blades and spindles to be sure that no foreign objects, such as wire or steel strapping bands, are wrapped around them.
2. Inspect blades for wear. Replace if necessary. If it is necessary to sharpen the blades, remove the blades from the spindles before sharpening. DO NOT sharpen blades while still attached to the mower.
3. Make sure all shields are in place and in good condition. Repair or replace any missing or damaged shields.
4. Listen for abnormal sounds, which might indicate loose parts, damaged bearings, or other damage. Correct any deficiency before continuing operation.
5. Check for wear or deterioration of the upper or lower hoses. If there are any portions of the hose that have been torn or worn through, replace with genuine PECO parts.

After Each Use:

1. Clean all debris from machine especially from the container, and off of safety decals. Replace any missing or illegible decals.
2. Clean all debris from the box screen.
3. Inspect unit for worn or damaged components. Repair or replace before the next use. Any replacement component installed during repair shall include the components current safety decal specified by the manufacturers to be affixed to the component.

SECTION V - PARTS AND SERVICE

Parts And Service Information

PECO collection system owners should record the name and telephone number of their Service Center. Your Service Center will be happy to supply replacement parts, accessories, and do any service or repairs to your collection system. If for any reason your Service Center is unable to service your collection system or supply replacement parts, contact PECO and include the following information on the chart below.

DOCUMENT THE FOLLOWING INFORMATION FOR FUTURE REFERENCE

Unit Model Number: _____

Unit Engine Size: _____

Unit Serial Number: _____

Date of purchase: ____ / ____ / ____

Dealer/Distributor Name: _____

Address: _____ **State:** _____ **Zip:** _____

Phone Number: _____

New PECO, Inc.
10 Walden Dr | Arden, North Carolina 28704
Phone: 1-800-438-5823 | 828-684-1234
Fax: 828-684-0858
Email: peco@lawnvac.com
Website: www.lawnvac.com

TORQUE SPECIFICATIONS

Proper torque for American fasteners used on Peco equipment.
Recommended Torque in Foot Pounds (Newton Meters).*

AMERICAN

Bolt Head Markings

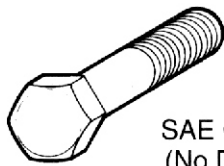

SAE Grade 2
(No Dashes)

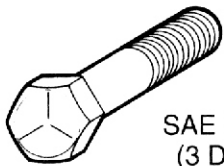

SAE Grade 5
(3 Dashes)

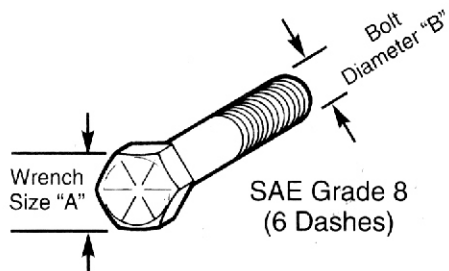

SAE Grade 8
(6 Dashes)

WRENCH SIZE (IN.) "A"	BOLT DIAMETER (IN.) "B" AND THREAD SIZE	SAE GRADE 2	SAE GRADE 5	SAE GRADE 8
7/16	1/4 - 20 UNC	6 (7)	8 (11)	12 (16)
7/16	1/4 - 28 UNF	6 (8)	10 (13)	14 (18)
1/2	5/16 - 18 UNC	11 (15)	17 (23)	25 (33)
1/2	5/16 - 24 UNF	13 (17)	19 (26)	27 (37)
9/16	3/8 - 16 UNC	20 (27)	31 (42)	44 (60)
9/16	3/8 - 24 UNF	23 (31)	35 (47)	49 (66)
5/8	7/16 - 14 UNC	32 (43)	49 (66)	70 (95)
5/8	7/16 - 20 UNF	36 (49)	55 (75)	78 (106)
3/4	1/2 - 13 UNC	49 (66)	76 (103)	106 (144)
3/4	1/2 - 20 UNF	55 (75)	85 (115)	120 (163)
7/8	9/16 - 12 UNC	70 (95)	109 (148)	153 (207)
7/8	9/16 - 18 UNF	79 (107)	122 (165)	172 (233)
15/16	5/8 - 11 UNC	97 (131)	150 (203)	212 (287)
15/16	5/8 - 18 UNF	110 (149)	170 (230)	240 (325)
1-1/8	3/4 - 10 UNC	144 (195)	266 (360)	376 (509)
1-1/8	3/4 - 16 UNF	192 (260)	297 (402)	420 (569)
1-5/16	7/8 - 9 UNC	166 (225)	430 (583)	606 (821)
1-5/16	7/8 - 14 UNF	184 (249)	474 (642)	668 (905)
1-1/2	1 - 8 UNC	250 (339)	644 (873)	909 (1232)
1-1/2	1 - 12 UNF	274 (371)	705 (955)	995 (1348)
1-1/2	1 - 14 UNF	280 (379)	721 (977)	1019 (1381)
1-11/16	1-1/8 - 7 UNC	354 (480)	795 (1077)	1288(1745)
1-11/16	1-1/8 - 12 UNF	397 (538)	890 (1206)	1444 (1957)
1-7/8	1-1/4 - 7 UNC	500 (678)	1120 (1518)	1817 (2462)
1-7/8	1-1/4 - 12 UNF	553 (749)	1241 (1682)	2013 (2728)
2-1/16	1-3/8 - 6 UNC	655 (887)	1470 (1992)	2382 (3228)
2-1/16	1-3/8 - 12 UNF	746 (1011)	1672 (2266)	2712 (3675)
2-1/4	1-1/2 - 6 UNC	870 (1179)	1950 (2642)	3161 (4283)
2-1/4	1-1/2 - 12 UNF	979 (1327)	2194 (2973)	3557 (4820)

METRIC

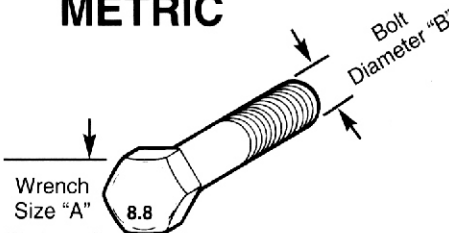

Numbers appearing on bolt heads indicate ASTM class.

Proper torque for metric fasteners used on Peco equipment.
Recommended torque in foot pounds (newton Meters).*

WRENCH SIZE (mm) "A"	BOLT DIA. (mm) "B"	ASTM 4.6	ASTM 8.8	ASTM 9.8	ASTM 10.9
8	5	1.8 (2.4)		5.1 (6.9)	6.5 (8.8)
10	6	3 (4)		8.7 (12)	11.1 (15)
13	8	7.3 (10)		21.1 (29)	27 (37)
16	10	14.5 (20)		42 (57)	53 (72)
18	12	25 (34)	74 (100)	73 (99)	93 (126)
21	14	40 (54)	118 (160)	116 (157)	148 (201)
24	16	62 (84)	167 (226)	181 (245)	230 (312)
30	20	122 (165)	325 (440)		449 (608)
33	22		443 (600)		611 (828)
36	24	211 (286)	563 (763)		778 (1054)
41	27		821 (1112)		1138 (1542)
46	30	418 (566)	1119 (1516)		1547 (2096)

*Use 75% of the specified torque value for plated fasteners. Use 85% of the specified torque values for lubricated fasteners.

Troubleshooting

2017 (v1.0)

Collection System Performance

Problem	Possible Cause	Corrective Action
Abnormal Vibration	<ul style="list-style-type: none"> • Cutting blades are bent or unbalanced • Loose blower pulley or pulley assembly • Impeller blade out of balance 	<ul style="list-style-type: none"> • Install new cutting blade • Tighten the pulley • Contact dealer to replace
Reduced collection system performance	<ul style="list-style-type: none"> • Low engine speed • Plugged screen • Loose belt • Full collection bags 	<ul style="list-style-type: none"> • Always operate collection system at full throttle • Remove debris, leaves, or grass clippings from the screen • Replace/tighten belt • Empty the collection bags
Blower and hoses plugging too frequently	<ul style="list-style-type: none"> • Collection bags are too full • Low engine speed • Grass is too wet • Grass is too long • Ground speed is too fast • Worn belt • Loose belt 	<ul style="list-style-type: none"> • Dump more frequently • Always operate collection system at full throttle • Cut grass when it is dry • Cut the grass several times • Drive slower at full throttle • Replace belt • Adjust the pulley and tighten belts
Debris blowout	<ul style="list-style-type: none"> • Collection bags are too full • Plug/clog in the collection system • Ground speed is too fast 	<ul style="list-style-type: none"> • Dump more frequently • Clean the collection system • Drive more slowly at full throttle
Impeller doesn't rotate freely	<ul style="list-style-type: none"> • Plug in the blower housing • Worn impeller blade • Shaft bearings bad/failing 	<ul style="list-style-type: none"> • Clean the blower housing • Contact dealer to replace • Contact dealer to replace

Notes



New PECO, Inc.
10 Walden Dr | Arden, North Carolina 28704
Phone: 1-800-438-5823 | 828-684-1234
Fax: 828-684-0858
Email: peco@lawnvac.com
Website: www.lawnvac.com