



Unit Model #: 38131510

Mower: Dixie Chopper Eagle HP / Jacobsen ZT1000

Owner's Manual: Q0577

Mower Type:

Deck Size: 60", 66" & 72"

Vac Type: 15 Cubic Foot Pro 3B

Deck Type:

Drive Type: PTO-X Drive

Revision #: 0

Fits Year(s): 2018 - 2020

A2322 Vac Kit

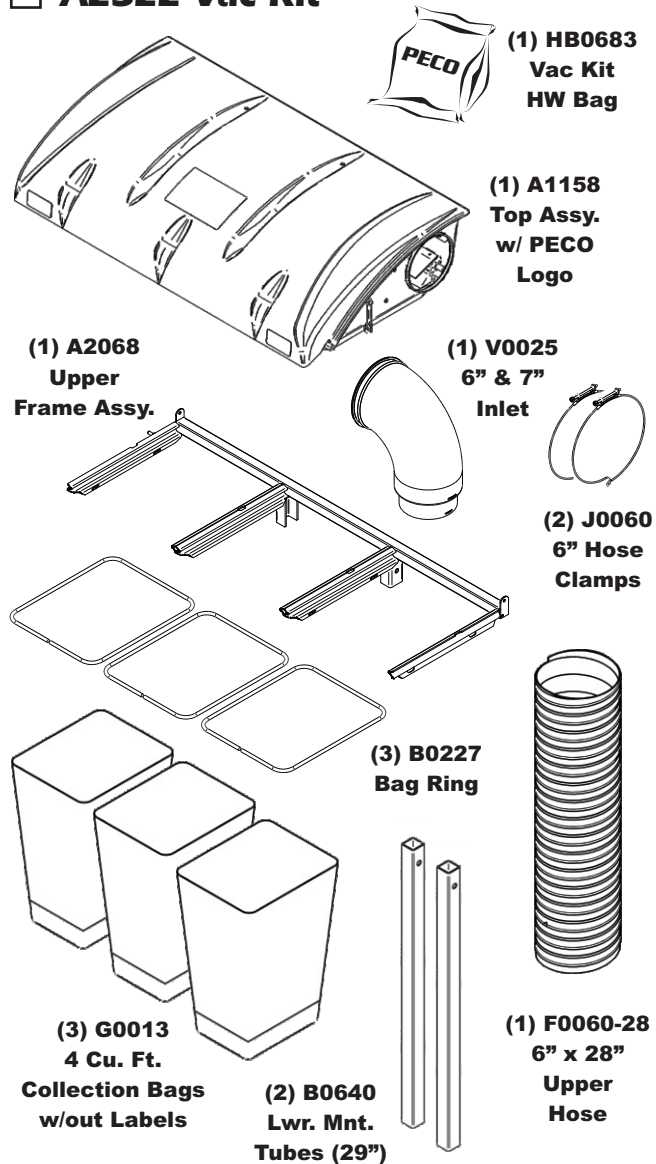

A2354 Mount Kit

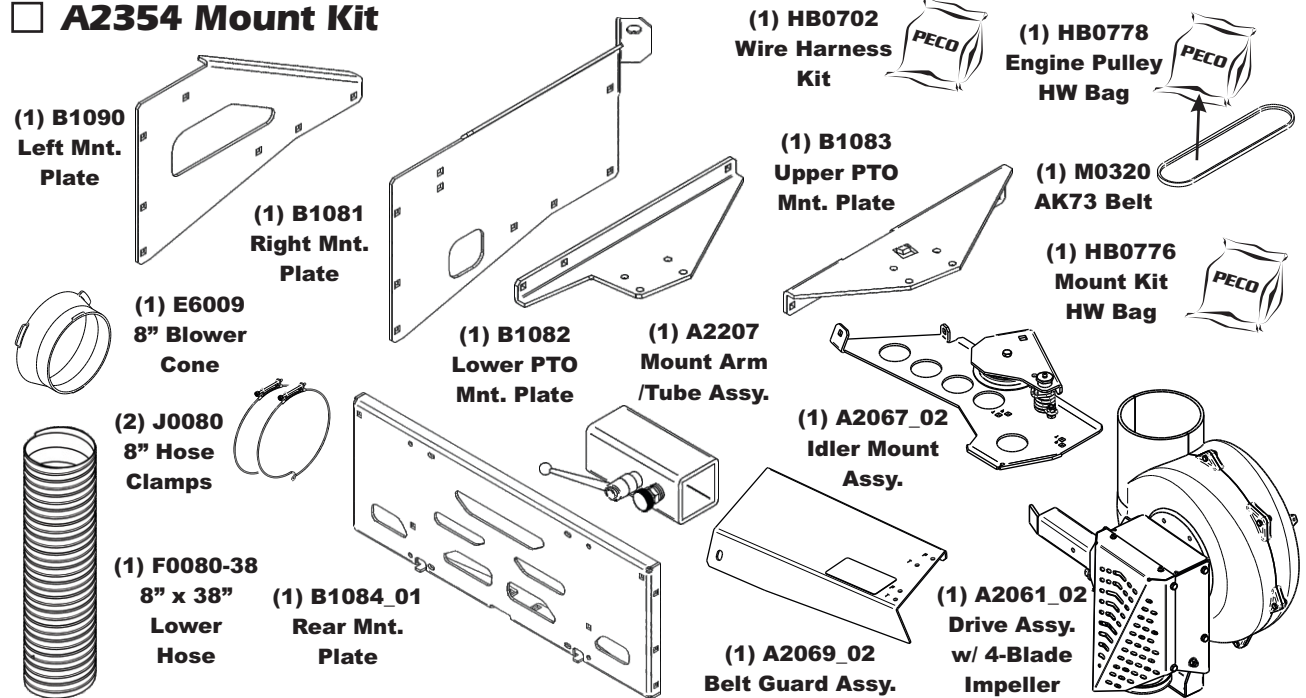

A2375 Dual Weight Kit

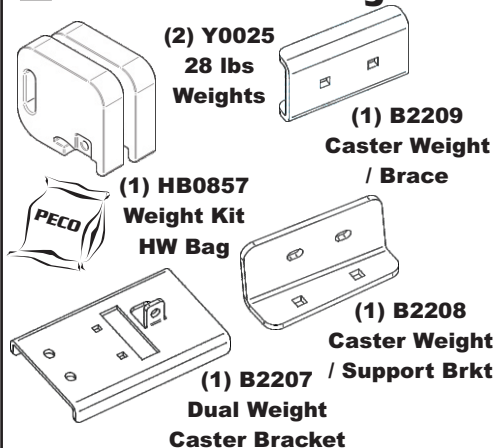

A2376 Quad Weight Kit

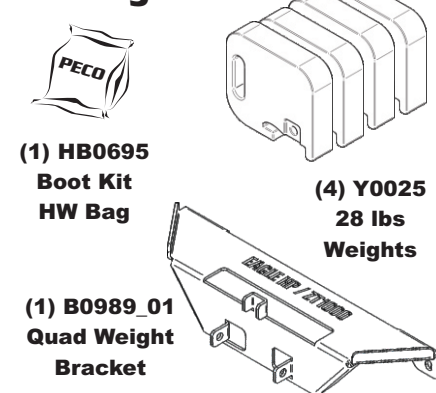

A2130 Boot Kit

