



Unit Model #: 38120905 / 07120901

Mower: Dixie Chopper BlackHawk/HP / Jacobsen ZT400 & ZT600

Owner's Manual: Q0515

Mower Type: 2248KW, 2548KOE, 2454KW, 2554BR, 2554KOE, 2460KW, 2560BR & 2560KOE

Deck Size: 48", 54" & 60"

Vac Type: 9 Cubic Foot Pro 2+ Bagger

Deck Type:

Drive Type: PTO Drive

Revision #: 2 (Updated Mount Kit)

Fits Year(s): 2016 - 2018

A2132 Vac Kit

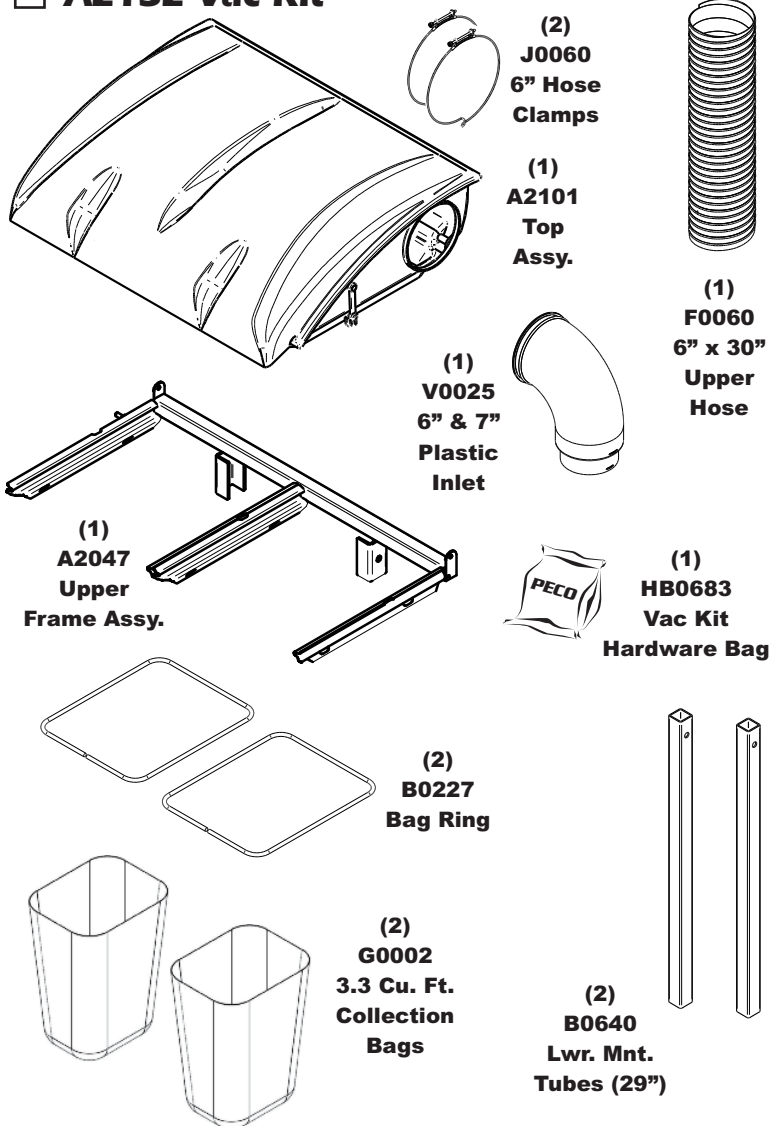

A2216 Mount Kit

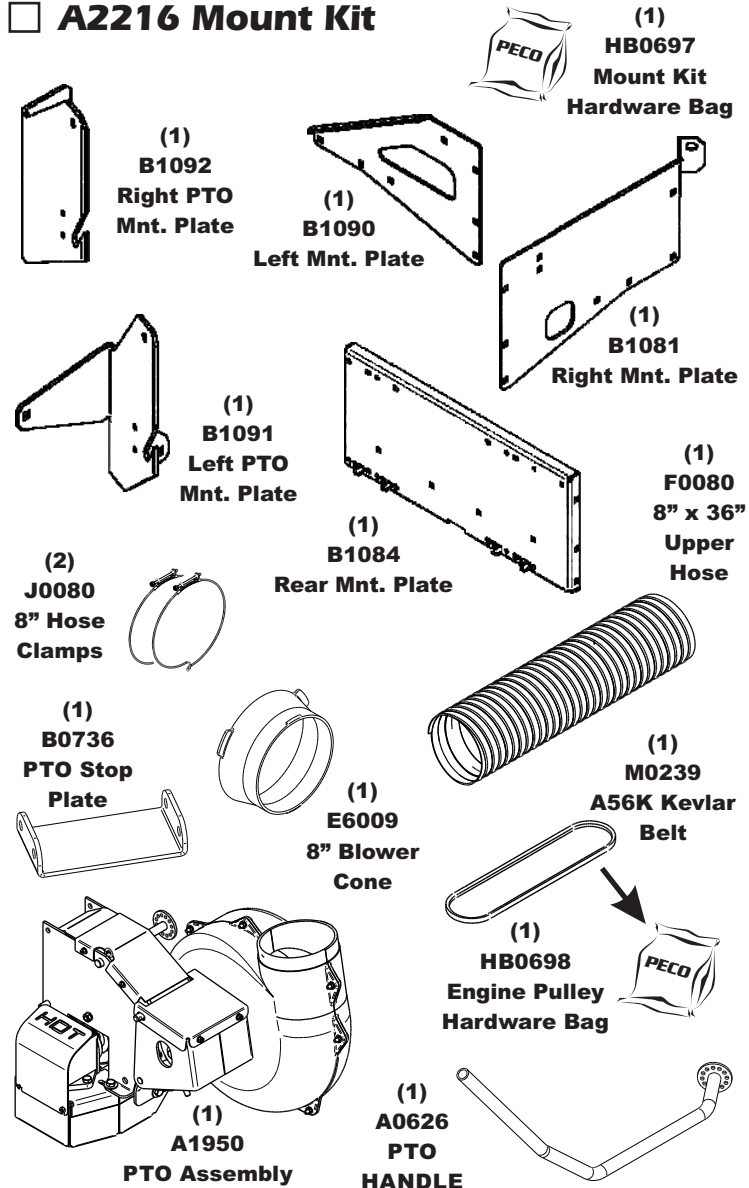

A2130 Boot Kit

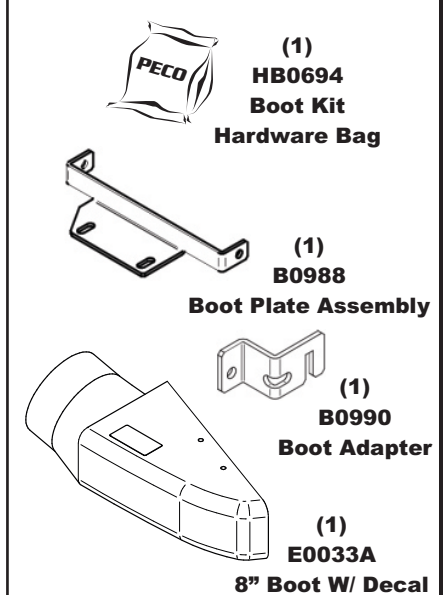

A2131 Weight Kit

