



# PTO-X Driven - GRASS COLLECTION SYSTEM

Model# 47131506



**BUSH HOG**®

## HDC Series ZT

55" & 61" DECKS

MODEL YEAR:

**2018-NEWER**



# OPERATOR'S MANUAL

ASSEMBLY • OPERATION • MAINTENANCE

# GRASS COLLECTION SYSTEM

## TABLE OF CONTENTS

SECTION	PAGE	SECTION	PAGE
Safety	2	Boot Kit Installation	19
Safety Alert Symbols	3	Exhaust Guard Installation	20
Warranty	4	Length of Hose Adjustment	21
I INTRODUCTION AND DESCRIPTION	5	Upper Hose Installation	21
Introduction	5	Lower Hose to Blower Cone Installation	21
Description	5	Lower Hose to Boot Installation	21
II INSTALLATION FOR USE	6	Impeller Blade Removal/Replacement	22
Preparation Of Mower	6	Wiring Harness Installation	23-24
Mount Kit Assembly Installation	7	Weight Kit Installation	25
Frame Bracket Spacer Assembly & Installation	8-9	Exploded Views & Parts List	26-34
Rear Frame Bracket Installation	10	Overall Parts List	35
Lower Mount Tube Installation	11	Safety Decals	36
Upper Frame Assy Installation	12	III OPERATING INSTRUCTIONS	37
PTO Drive Assy Installation	13-14	General Safety	37
Drive Assy & Belt Installation	15	Operation & Tips On Mowing	37
Top Assy To Upper Frame Assy Installation	16	Disengagement Of The PTO Assembly	37
Inlet Installation	16	Unloading The Collection System	37
Hinge Kit Assy Installation	17	IV MAINTENANCE	37-38
Even Bag Fill Adjustment	17	Maintenance Checklist	38
Bag Assembly	18	Lubrication	38
Bag Assembly Installation	18	V PARTS AND SERVICE	38
Blower Cone Installation	19	Parts And Service Information	38
		Torque Specifications	39
		Troubleshooting	40

## SAFETY

1. Read the operator's manual carefully and familiarize yourself with the proper use of your attachment. Do not allow anyone who is not acquainted with the Safety Instructions to use your attachment.
2. Know the controls and how to stop them quickly. **READ THE OPERATOR'S MANUAL!**
3. Do not allow children to operate the machine. Do not allow adults to operate it without proper instruction.
4. Be especially watchful of children and pets entering into the area while operating.
5. Keep your eyes and mind on your machine while mowing or operating your attachment. Don't let others distract you.
6. Do not attempt to operate your machine when not in the driver's seat.
7. Always shut off blades and engine when emptying the container.
8. Stop machine, shut off deck attachment, set parking brake, shut off engine and remove ignition key before removing clogs, removing or replacing hose, boot, blower cone, or performing any maintenance.
9. Mow across the face of slopes (not more than 10 degrees); never up and down the face.
10. It is recommended that the container be emptied when half full while operating on slopes. Start mowing on slopes when the container is empty.
11. Inspect your lawn and remove any foreign objects before mowing. Never deliberately run the mower across any foreign object.
12. Wear hearing protection.
13. Wear eye protection to prevent debris from getting into your eyes.

# SAFETY

**WARNING!** NEVER operate the mower unless the discharge guard and either the deflector assembly or the vacuum collector adapter are fastened securely in place.

**WARNING!** Do not work around the mower deck boot or the blower area until you are certain that the mower blades and the blower impeller have stopped rotating.

**WARNING!** To avoid serious injury, perform maintenance on the vacuum collector; **ONLY AFTER STOPPING THE MOWER'S ENGINE AND WAITING FOR ALL MOVING PARTS TO COME TO A COMPLETE STOP.** Set the parking brake. Always remove the ignition key before beginning maintenance.

**WARNING!** For your own personal safety, **ALWAYS mow ACROSS the face of slopes and NEVER UP and DOWN the face. NEVER attempt to mow excessively steep slopes, and use caution when turning on any slope.**

## Safety Alert Symbol



This Safety Alert Symbol means: **“ATTENTION! BECOME ALERT! YOUR SAFETY IS INVOLVED!”**

This symbol is used to call attention to safety precautions that should be followed by the operator to avoid accidents. When you see this symbol, carefully read the message that follows and heed its advice. Failure to comply with safety precautions could result in death or serious bodily injury.

## Safety Signs

The signal words **DANGER**, **WARNING**, and **CAUTION** are used on the equipment safety signs. These words are intended to alert the viewer to the existence and the degree of hazard seriousness.



White letters on **RED**

This signal word indicates a potentially hazardous situation which, if not avoided, will result in death or serious injury.



Black letters on **ORANGE**

This signal word indicates a potentially hazardous situation which, if not avoided, could result in death or serious injury.

It may also be used to alert against unsafe practices.



Black letters on **YELLOW**

This signal word indicates a potentially hazardous situation which, if not avoided, will result in minor or moderate injury.

It may also be used to alert against unsafe practices.

# PECO LIMITED WARRANTY FOR NEW PRODUCTS

New PECO, Inc. extends the following warranties to the ORIGINAL PURCHASER of each New PECO, Inc. consumer product purchased from one of our Dealers or directly from New PECO, Inc., subject to the following limitations:

## **A. ITEMS COVERED UNDER WARRANTY**

1. **PRODUCT WARRANTY** – Any part or parts which are deemed defective in material or workmanship, as delivered to the original purchaser, will either be repaired or replaced, as New PECO, Inc. elects, without charge for parts or labor, if the defect appears within 12 months from the date of purchase of the product to the Original Purchaser.
2. **PARTS REPLACED DURING WARRANTY** – Any New PECO, Inc. part which is furnished in performance of this warranty and is defective in material or workmanship as delivered to the purchaser will be repaired or replaced, as New PECO, Inc. elects, before the expiration of the original warranty period.

## **B. WARRANTY DISTINCTIONS**

1. **RESIDENTIAL** - Products put to a personal use around a single household or residence are considered Residential. Products designated as “Residential” are warranted for 12 months from the date of purchase of the product, to the ORIGINAL PURCHASER with proof of purchase, when used for or in residential applications.
2. **COMMERCIAL** – Products put to any business use (agricultural, commercial or industrial) or used at multiple locations are considered Commercial. Products designated as “Commercial” are warranted for 12 months from the date of purchase of the product, to the ORIGINAL PURCHASER with proof of purchase, when used for or in commercial applications. Products designated as “Residential” are warranted for 90 days from the date of purchase of the product, to the ORIGINAL PURCHASER with proof of purchase, when used for or in Commercial applications.
3. **RENTAL** – Products used for Rental or Lease Purposes are warranted for 45 days from date of purchase of the product, to the ORIGINAL PURCHASER with proof of purchase, when used for or in a rental business.

## **C. ITEMS NOT COVERED BY NEW PECO WARRANTY**

1. **ENGINES & BATTERIES:** Engines and Batteries attached to New PECO, Inc. products are covered under their respective separate manufacturer warranties and those companies must be contacted directly to file a warranty claim. Briggs & Stratton: [https://www.briggsandstratton.com/na/en\\_us/support/warranty.html](https://www.briggsandstratton.com/na/en_us/support/warranty.html)
2. **UNAPPROVED ALTERATION OR MODIFICATION:** All obligations of New PECO, Inc. under this warranty shall be terminated if products are altered or modified in any way not approved by New PECO, Inc.
3. **ACCIDENTS & NORMAL MAINTENANCE:** This warranty covers ONLY manufacturers defective material and workmanship. It does not cover depreciation or damage caused by normal wear & tear, accident, improper maintenance, misuse or abuse of products. New PECO, Inc. products must be operated and maintained in accordance with the instructions furnished in the manuals. The cost of normal maintenance and normal replacement of service items such as belts, cutting blades, hoses, bags, etc., which are not defective shall be paid for by the purchaser.
4. **NO SERVICE CENTER WARRANTY:** The selling Service Center/Dealer makes no warranty on his own on any item warranted by New PECO, Inc. unless he delivers to purchaser a separate written warranty certificate specifically warranting the item. The Service Center or Dealer has no authority to make any representation or promise on behalf of New PECO, Inc. or to modify the terms of the original warranty in any way.
5. **NO REPRESENTATIONS ADDITIONAL WARRANTIES, DISCLAIMER:** Neither New PECO, Inc. nor any company affiliated with New PECO, Inc. makes any warranties, representations or promises as to the quality of performance of its products other than those set forth herein. Except as described above, New PECO, Inc. makes no other warranties **AND SPECIFICALLY DISCLAIMS ANY AND ALL IMPLIED WARRANTIES OF FITNESS AND MERCHANTABILITY.**
6. **REMEDIED EXCLUSIVE:** The only remedies the purchaser has in connection with the breach or performance of any warranty on New PECO, Inc. consumer products are set forth above. In no event will New PECO, Inc. be liable for special incidental or consequential damages.

Warranty service is available through your local authorized service dealer or distributor. If you do not know the dealer or distributor in your area, search by your zip code on [www.lawnvac.com](http://www.lawnvac.com) or contact our Sales Department at New PECO, Inc. 800-438-5823 or email [Sales@lawnvac.com](mailto:Sales@lawnvac.com).

# Section I - INTRODUCTION AND DESCRIPTION

## Introduction

We are pleased to have you as a PECO customer. Your collection system has been designed to give you a low maintenance, simple, and effective way to collect the grass clippings from your mower. The manuals are provided to give you the necessary instructions to properly mount, operate and maintain the collection system on your mower. Please read this manual thoroughly. Understand what each control is for and how to use it. Observe all safety decal precautions on the machine and noted throughout the manual.

**NOTE:** All references made to right, left, front, rear, top or bottom are as viewed from the normal operator's position on the mower.

## Description

The grass collection system is designed for turf maintenance where there is a need to collect the grass clippings as the mower cuts the turf. It is also used for picking up leaves in pre-season and post-season clean-up. The blower, mounted on the right side of the unit, uses a belt and gearbox system from the engine PTO shaft. Drive train protection comes through belt slippage. The blower draws grass clippings from the discharge area of the cutting deck back to the collection bags at the rear portion of the mower frame. The operator can engage the blower with a toggle switch mounted on the control panel to the right of the operator. Once the bags are full with clippings, they can be easily released for dumping.



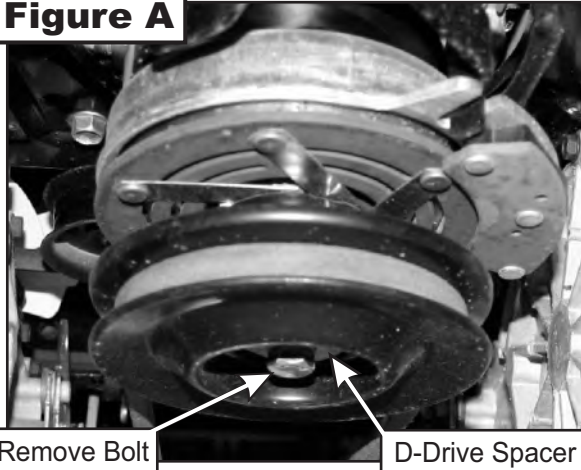
## Section II - INSTALLATION FOR USE

### Preparation Of Mower

**NOTE:** The mower deck PTO belt must be removed from the electric clutch before continuing with the installation. Refer to your mower's owner's manual for instructions on PTO belt removal.

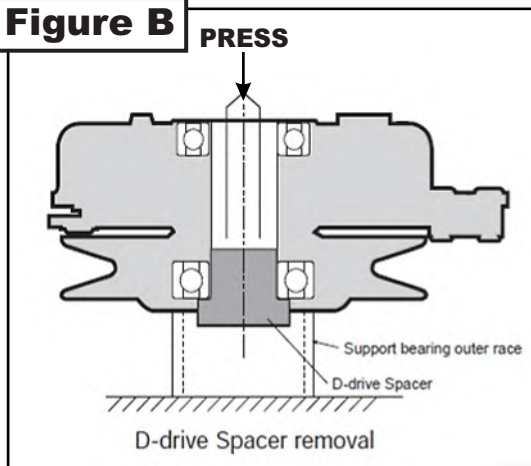
From the underside of the engine, disconnect the wiring harness attached to the electric clutch. Remove the bolt and electric clutch from the mower. Refer to Figure A.

**Figure A**

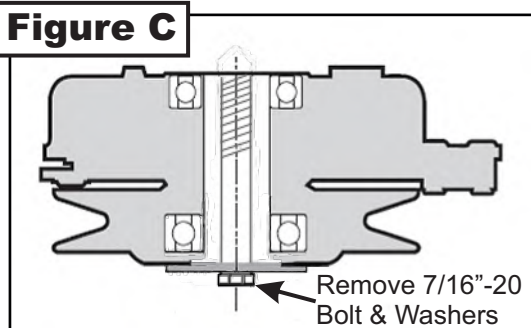


Upon removal of clutch determine if your mower is equipped with a D-drive spacer. If so, then proceed to Figure B. If your mower is equipped with bolt, fender and lock washer without D-drive spacer proceed to Figure C. Remove the D-drive spacer using an arbor press or equivalent. On removal, adjacent bearing OUTER race must be supported or bearing damage may occur. Refer to Figure B.

**Figure B**

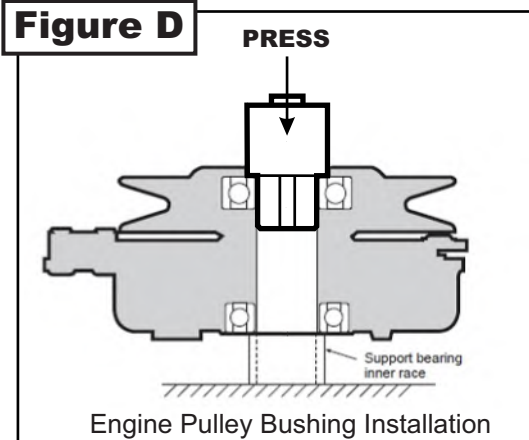


**Figure C**



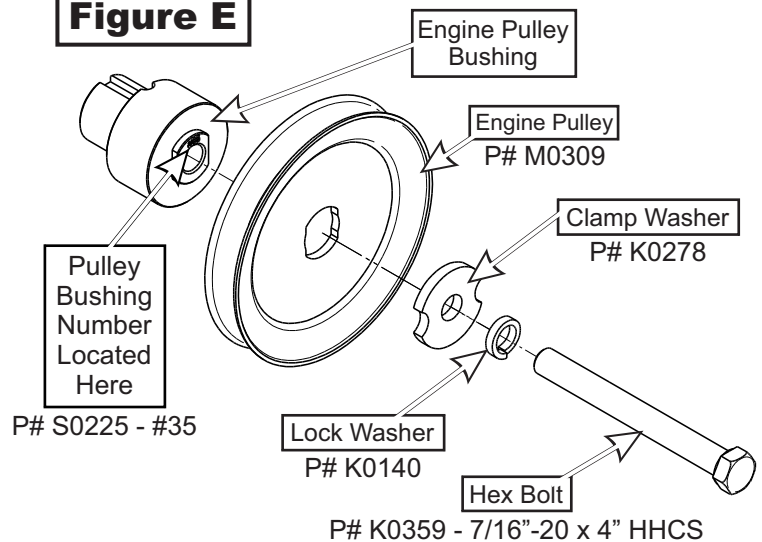
The engine pulley assembly must be installed using an arbor press or equivalent. During installation, opposite bearing inner race must be supported or bearing damage may occur. Refer to Figure D.

**Figure D**



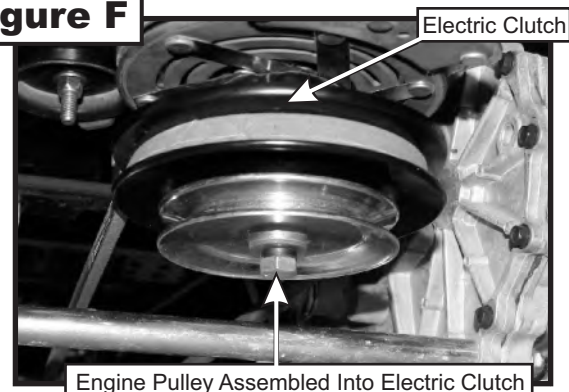
Once the Engine Pulley Bushing is installed, reattach the clutch assembly & deck PTO belt to the mower and then review Figure E.

**Figure E**



To assemble and fasten the Engine Pulley, align the Engine Pulley Bushing to the mower's clutch pulley and fasten using (1) Clamp Washer, (1) Lock Washer, and (1) Hex Bolt. Torque the bolt to 55 ft./lbs. The added pulley will power the collection system and should resemble Figure F when installed.

**Figure F**



## Mount Kit Assembly & Installation (2018-2019 Mower Model Year - Round ROPS)

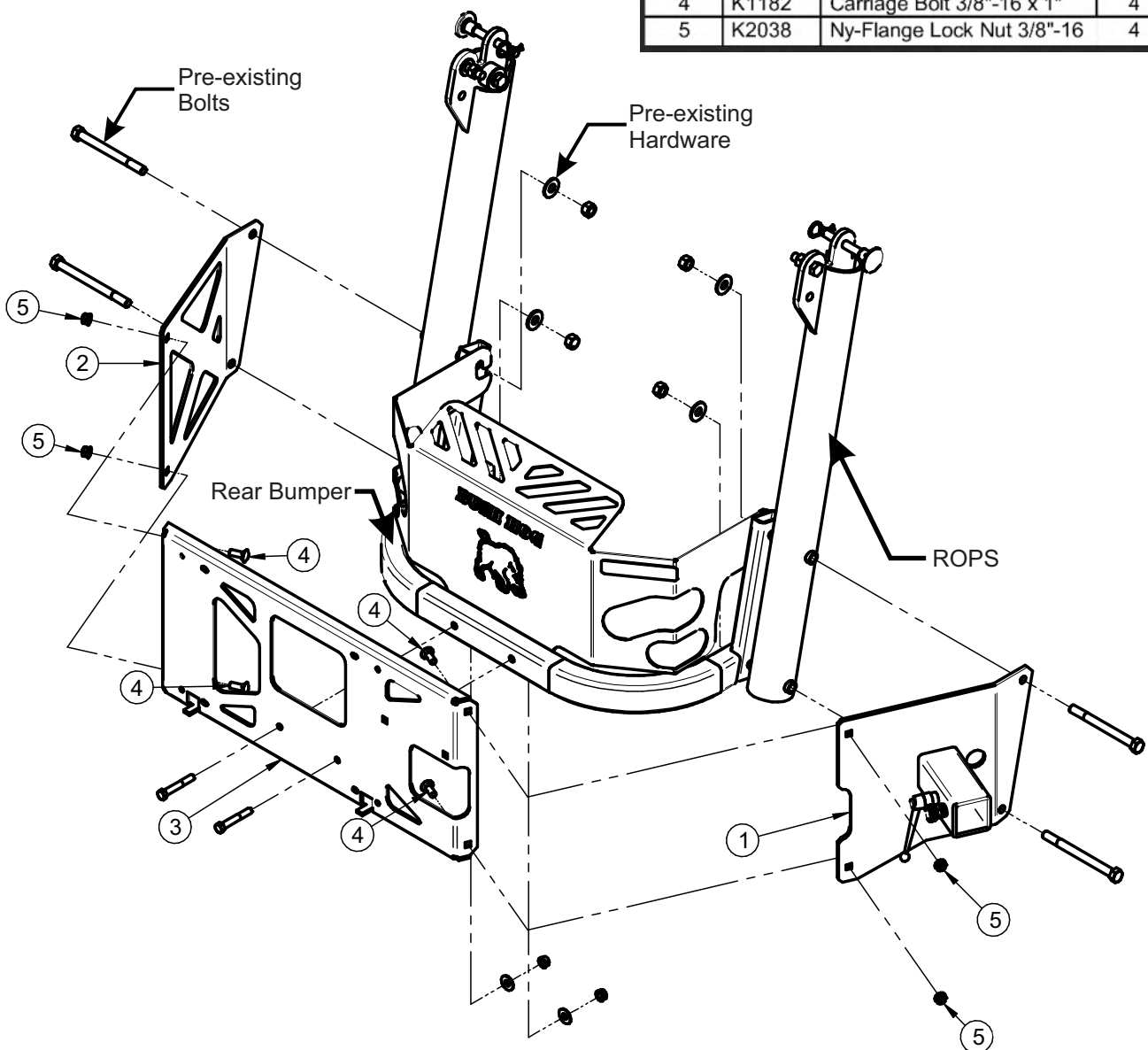
For the **2018 - 2019** Mower model years with round ROPS, follow the instructions on this page for the Main Frame Bracket Assembly & Installations.

First, install the Rear Frame Bracket (Item #3) by removing and setting aside the hardware of the hitch kit on the rear bumper of the mower. Align the two middle bolt holes of the Rear Frame Bracket to the two bolt holes of the rear bumper. Secure the Rear Frame Bracket using the existing hardware from earlier. (Refer to the figure below).

To Install the Left Frame Bracket (Item #2), remove and set aside the two pre-existing bolts and hardware located on the ROPS. Secure the Left Frame Bracket by aligning the bolt holes on the left side of the Left Frame Bracket to those on the ROPS and replacing the hardware while making sure that the two bolt holes on the right side of the Left Frame Bracket aligns with those on the Rear Frame Bracket. Secure the right side of the Left Frame Bracket using (2) 3/8"-16 x 1" Carriage Bolts (Item #4) and (2) 3/8" Ny Flange Lock Nut (Item #5). (Refer to the Figure below).

To Install the Mount Arm Sub-Assembly (Item #1), follow the same procedures as the Left Frame Bracket. (Refer to the Figure below).

Item #	Part #	Desc.	Qty.
1	A2137	Mount Arm Sub-Assembly	1
2	B1053	Left Frame Bracket	1
3	B1054	Rear Frame Bracket	1
4	K1182	Carriage Bolt 3/8"-16 x 1"	4
5	K2038	Ny-Flange Lock Nut 3/8"-16	4



## Frame Bracket Spacer Assembly & Installation

### (2020 - Newer Mower Model Year - Square ROPS)

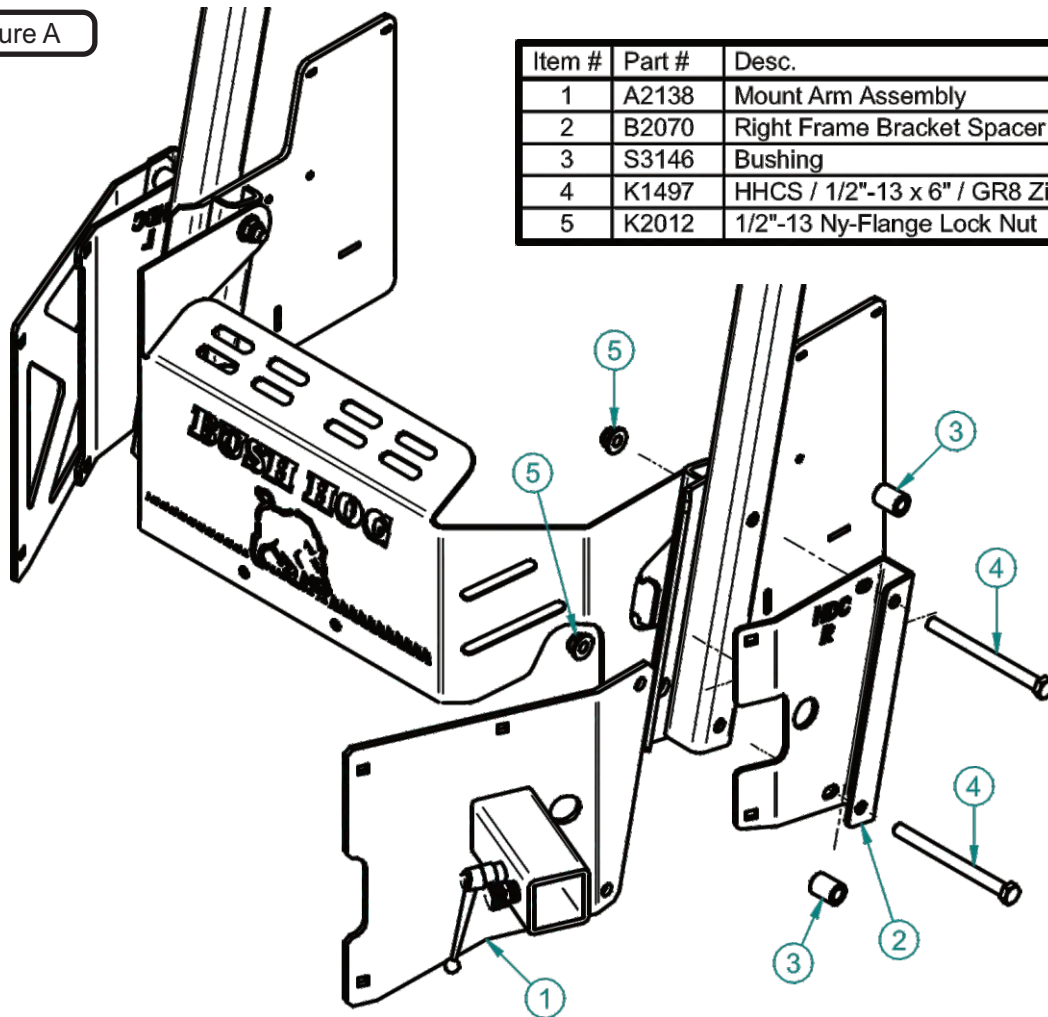
For the **2020 - Newer** Mower model years with square ROPS, follow the following instructions on page 8 through page 10 for the Assembly & Installations of your Frame Bracket Spacers & Frame Brackets.

For the installation of the Frame Bracket Spacer the hardware used on either side of the ROPS would need to be removed. The Mount Arm Assembly (Item #1) and Right Frame Bracket Spacer (Item #2) will need to be installed together.

First remove the set of bolts, and their respective hardware, that are used to secure the right side of the ROPS. Next, preassemble the Mount Arm Assy to the Right Frame Bracket Spacer by aligning the right side Mount Arm Assy mount holes to those on the Right Frame Bracket Spacer. Secure the Right Frame Bracket Spacer by using (2) Bushings (Item #3) and (2) 1/2"-13 x 6" HHCS (Item #4). Refer to Figure A and B. Position and insert the preassembled components over the ROPS mount holes and secure the components using (2) 1/2"-13 Ny-Flange Lock Nuts (Item #5).

Note: Some parts and part features have been hidden from view for visual clarity.

Figure A



Item #	Part #	Desc.	Qty.
1	A2138	Mount Arm Assembly	1
2	B2070	Right Frame Bracket Spacer	1
3	S3146	Bushing	2
4	K1497	HHCS / 1/2"-13 x 6" / GR8 Zinc	2
5	K2012	1/2"-13 Ny-Flange Lock Nut	2



## Frame Bracket Spacer Assembly & Installation (cont.)

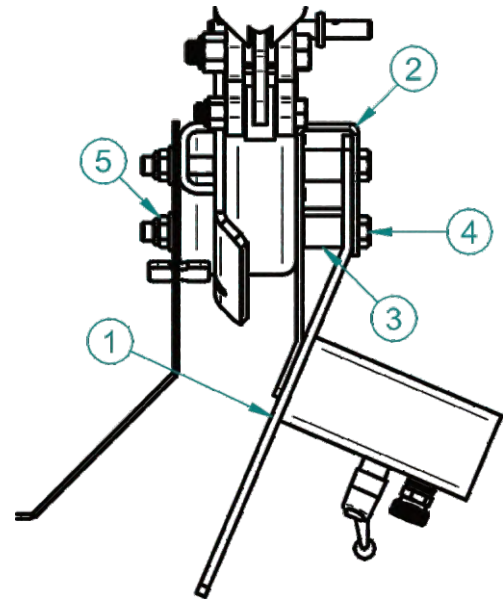
(2020 - Newer Mower Model Year)

Be sure to position the (2) Bushings (Item #4) and the Mount Arm Assembly (Item #1) between the Right Frame Bracket Spacer (Item #2). The (2) Bushings (Item #4) should be positioned behind the Mount Arm Assembly (Item #1). Refer to Figure B.

Note: Some parts and part features have been hidden from view for visual clarity.

Figure B

Item #	Part #	Desc.	Qty.
1	A2138	Mount Arm Assembly	1
2	B2070	Right Frame Bracket Spacer	1
3	S3146	Bushing	2
4	K1497	HHCS / 1/2"-13 x 6" / GR8 Zinc	2
5	K2012	1/2"-13 Ny-Flange Lock Nut	2



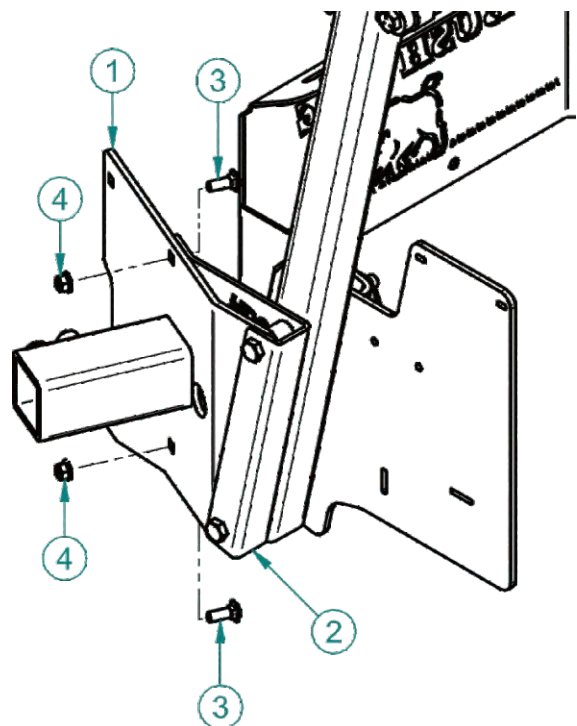
To fully secure the Mount Arm Assembly (Item #1) to the Right Frame Bracket Spacer (Item #2) align the second set of bolt holes of both parts as shown in Figure C and secure the two parts by using (2) 3/8"-16 x 1" Carriage Bolts (Item #3) and (2) 3/8"-16 Ny-Flange Lock Nuts (Item #4). Refer to Figure C below.

Repeat the same procedures for the Left Frame Bracket P#(B1053) & Left Frame Bracket Spacer P#(B2071).

Note: Some parts and part features have been hidden from view for visual clarity.

Figure C

Item #	Part #	Desc.	Qty.
1	A2138	Mount Arm Assembly	1
2	B2070	Right Frame Bracket Spacer	1
3	K1182	Carriage Bolt 3/8"-16 x 1"	2
4	K2038	Ny-Flange Lock Nut 3/8"-16	2



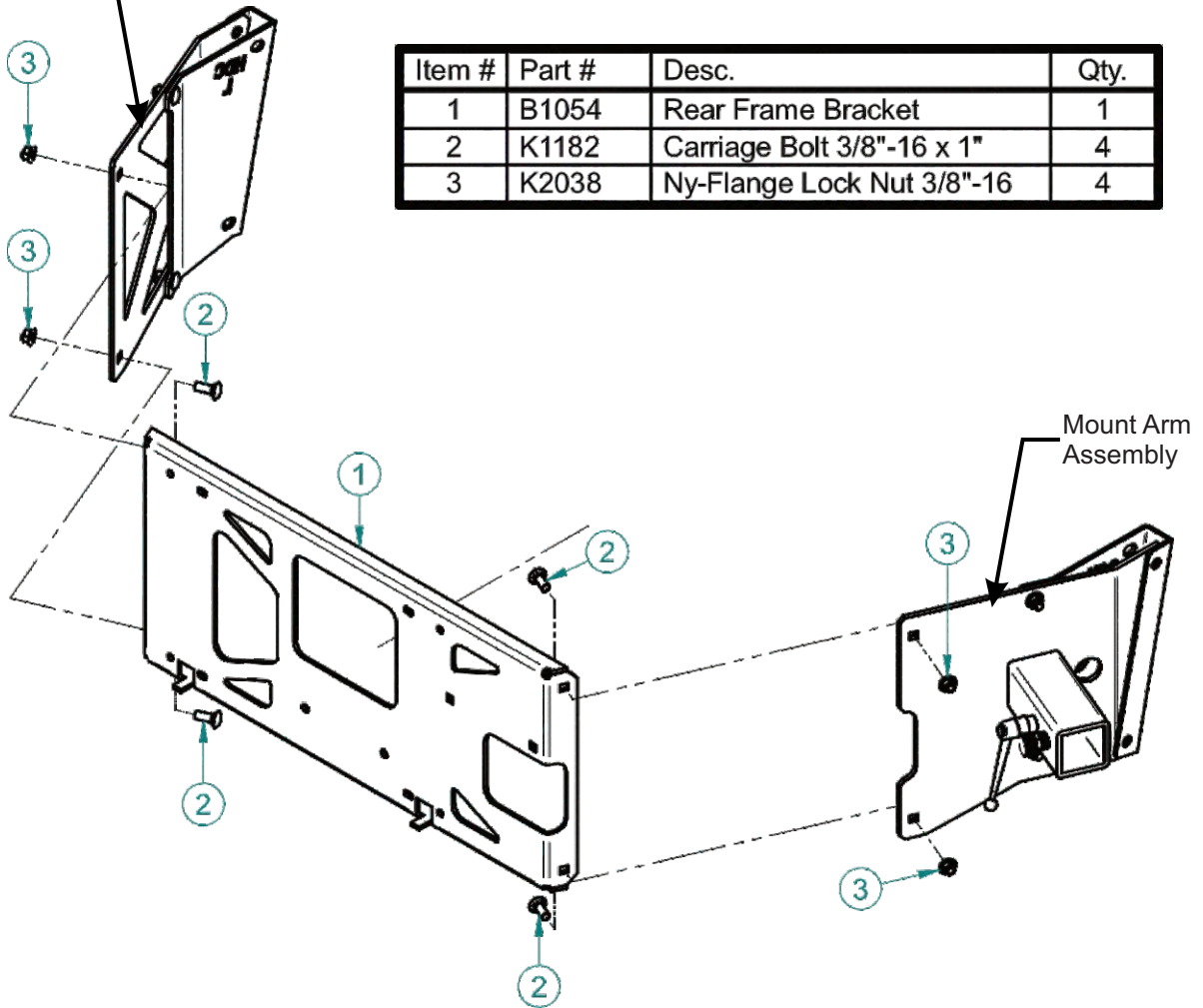
## Rear Frame Bracket Installation

(2020 - Newer Mower Model Year)

To install the Rear Frame Bracket (Item #1), position the Bracket between the Left Frame Bracket & Mount Arm Assembly. Align the (2) mount holes on either side of the Rear Frame Bracket to those located on the Left Frame Bracket & Mount Arm Assembly. Secure the Rear Frame Bracket by using (2) 3/8"-16 x 1" HHCS (Item #2) and (2) 3/8"-16 Ny-Flange Lock Nuts (Item #3) on both sides of the Rear Frame Bracket. Refer to the Figure Below.

Note: Some parts and part features have been hidden from view for visual clarity.

Left Frame Bracket

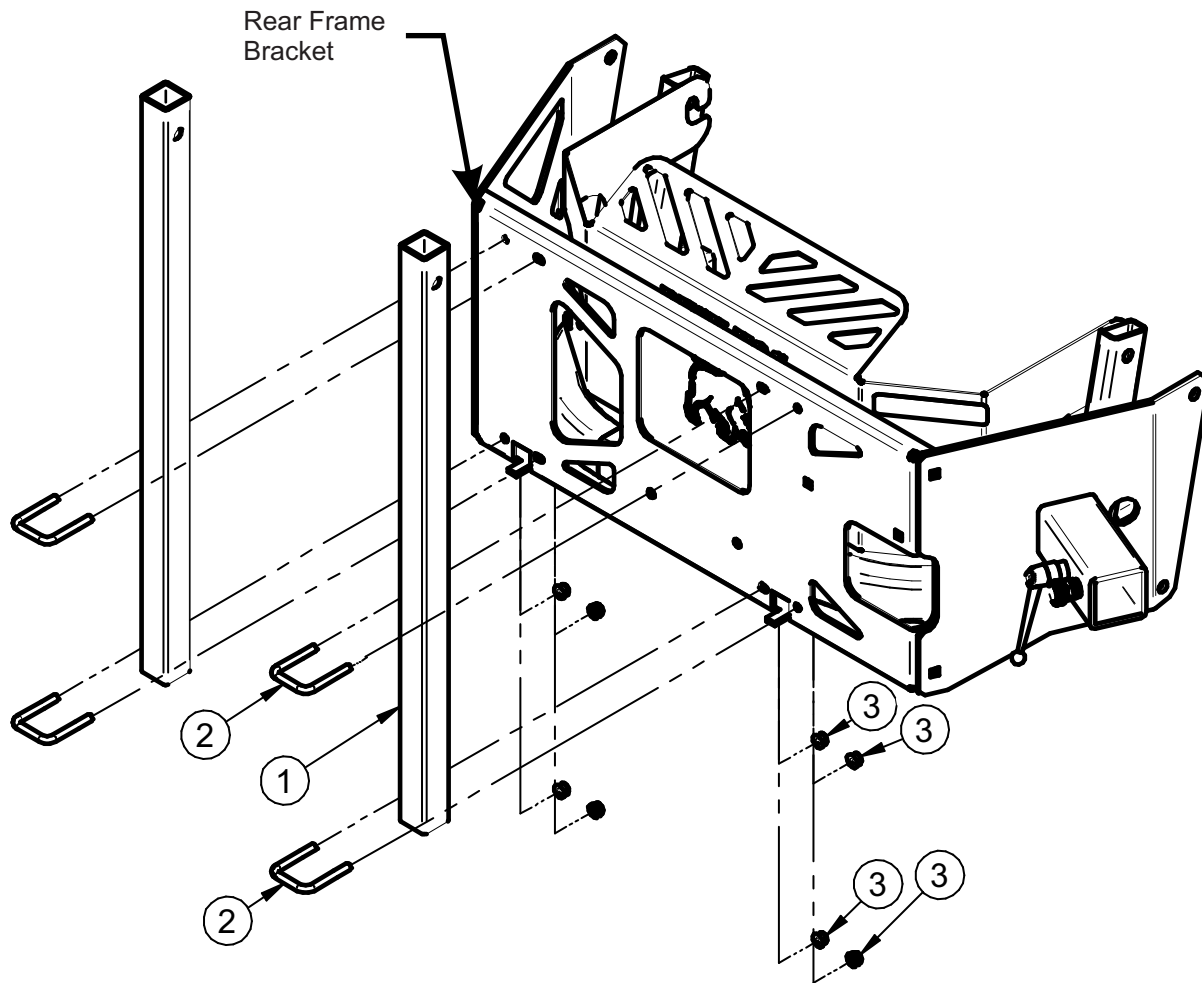


Mount Arm Assembly

## Lower Mount Tube Installation

Secure (2) Lower Mount Tubes (Item #1) to the Rear Frame Bracket using (2) 5/16"-18 x 2"-2-1/2" U-Bolt (Item #2) and (4) 5/16"-18 Ny-Flange Locknuts (Item #3) PER TUBE. Allow the Lower Mount Tubes to rest on the tabs of the Rear Frame Bracket. Refer to the Figure below.

Item #	Part #	Desc.	Qty.
1	B0640	Lower Mount Tube / 29"	1
2	K1098	U-Bolt / 5/16"-18 x 2-3/8" x 1-3/4"	2
3	K2516	Ny-Flange Lock Nut 5/16"-18	4



## Upper Frame Assembly Installation

Position the Upper Frame Assembly (Item #1) above the Lower Mount Tubes as shown in Figure A. Slide the Upper Frame Assembly down onto the Lower Mount Tubes and secure using (2) Clevis Pins (Item #2) and (2) Rue Ring Cotter Pin Clips (Item #3). Refer to Figure B.

Figure A

Item #	Part #	Desc.	Qty.
1	A2068	Upper Frame Assembly P3B Generic Gen 2	1
2	K0133	Clevis Pin 1/2" x 2-1/2"	2
3	K1437	Rue Ring Cotter Pin	1

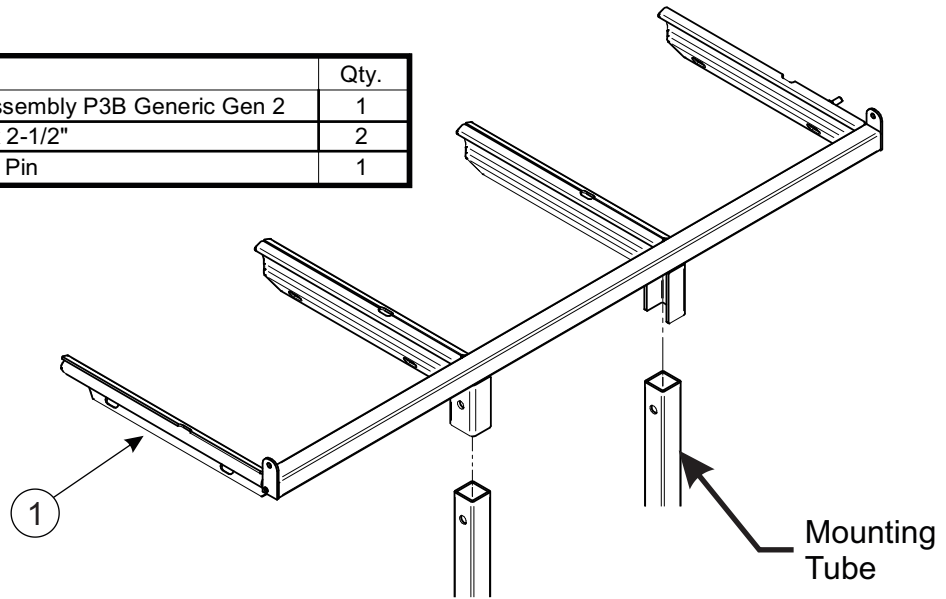
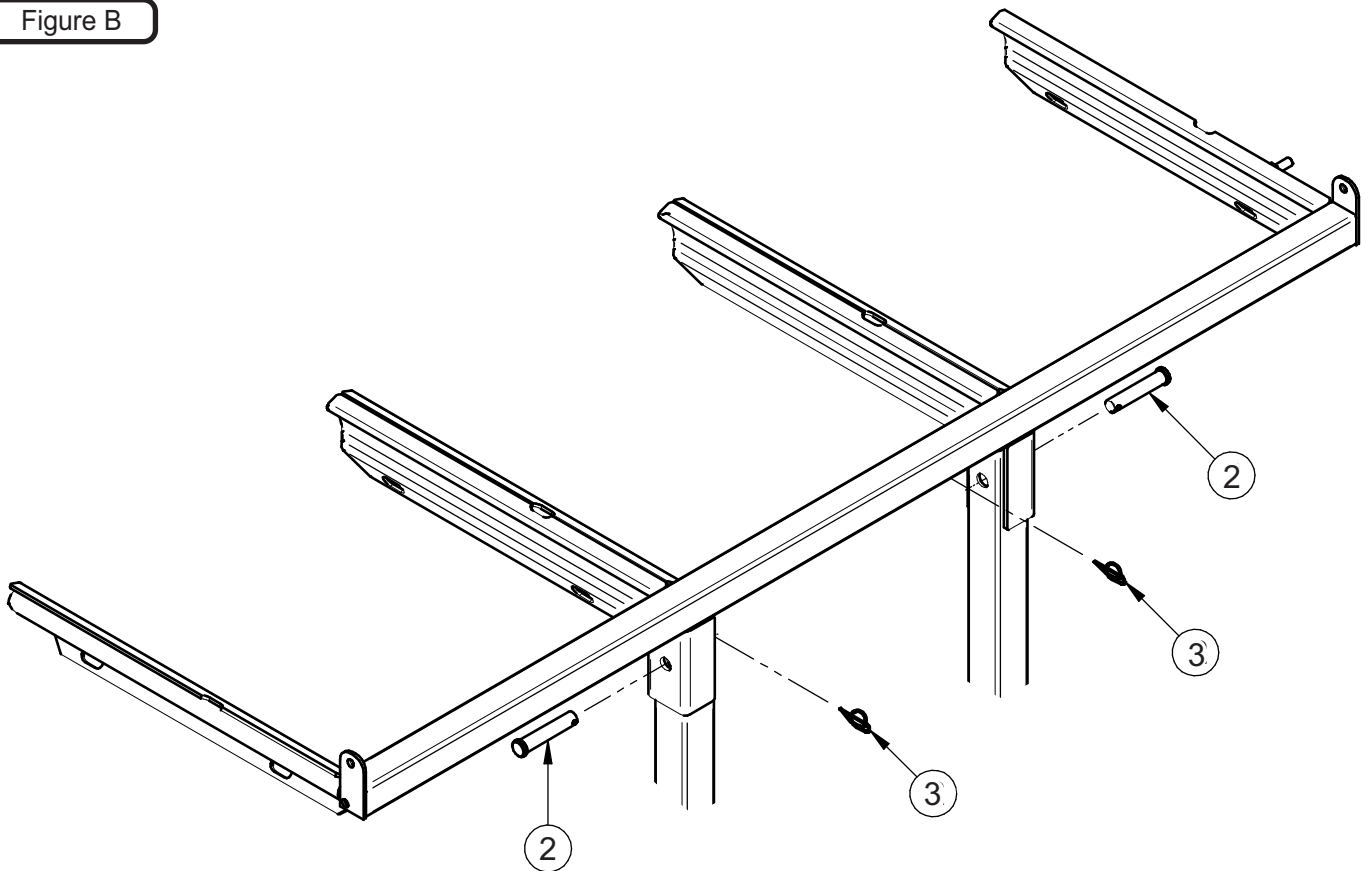


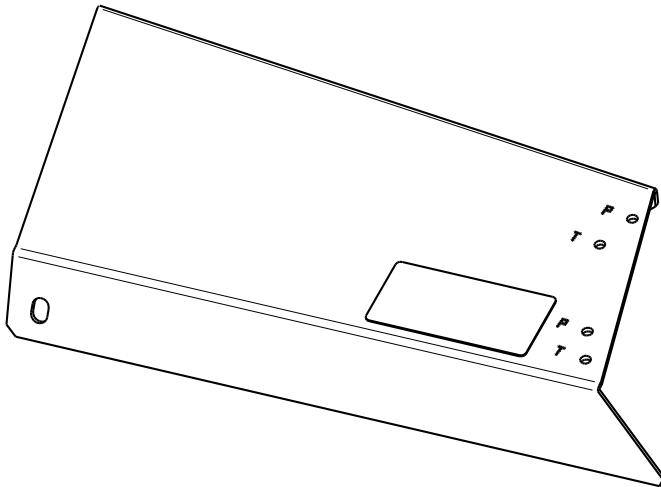
Figure B



## PTO Drive Assembly

Once the Mount Arm Assembly is installed and secured to the mower, assemble the Drive Assembly P#(A2061\_01), Belt Guard Assembly P#(A2069\_02) & Idler Mount Assembly P#(A2067\_02).

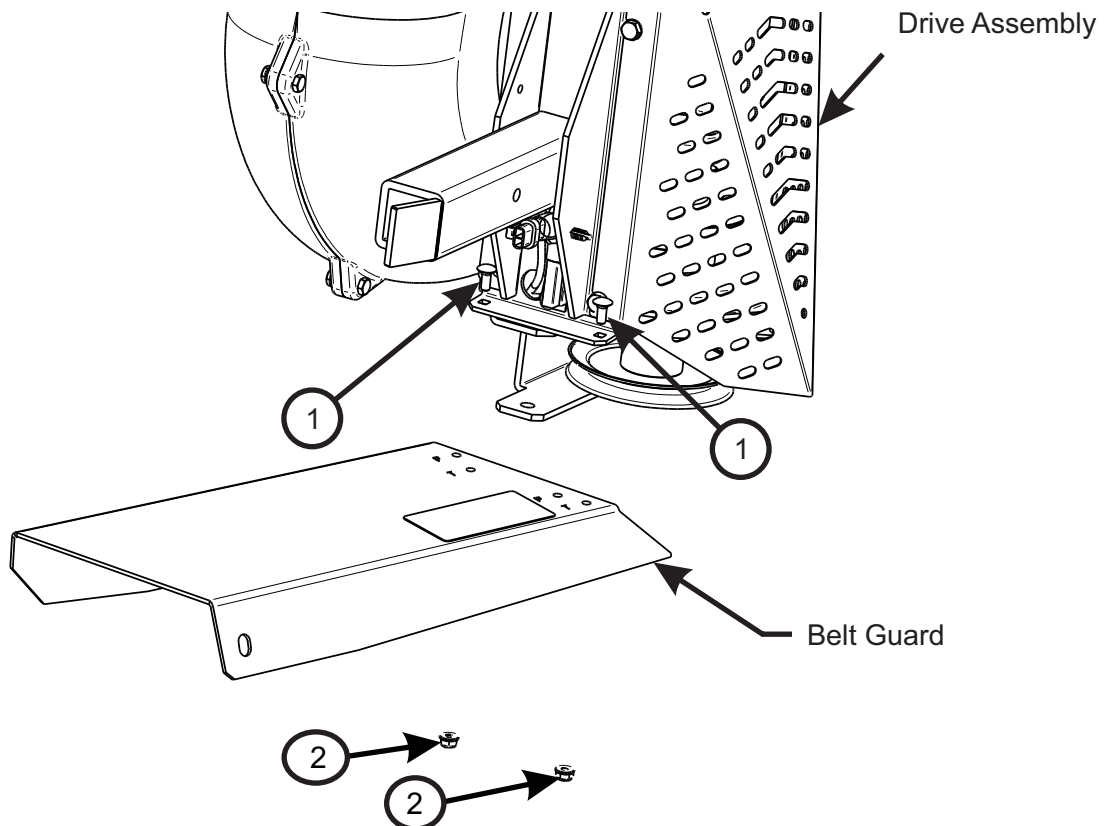
First, attach the Belt Guard Assembly P#(A2069\_02) to the Drive Assembly P#(A2061\_01) using (2) 1/4"-20 x 5/8" Carriage Bolts P#(K1010) and (2) 1/4"-20 Ny-Flange Lock Nuts P#(K2014). Refer to Figure A. **Leave Bolts Loose.**



### BELT GUARD ASSY. HOLES

Notice Marked Holes Below;  
For This Installation, Use Holes  
Marked With The Letter 'P'

Figure A

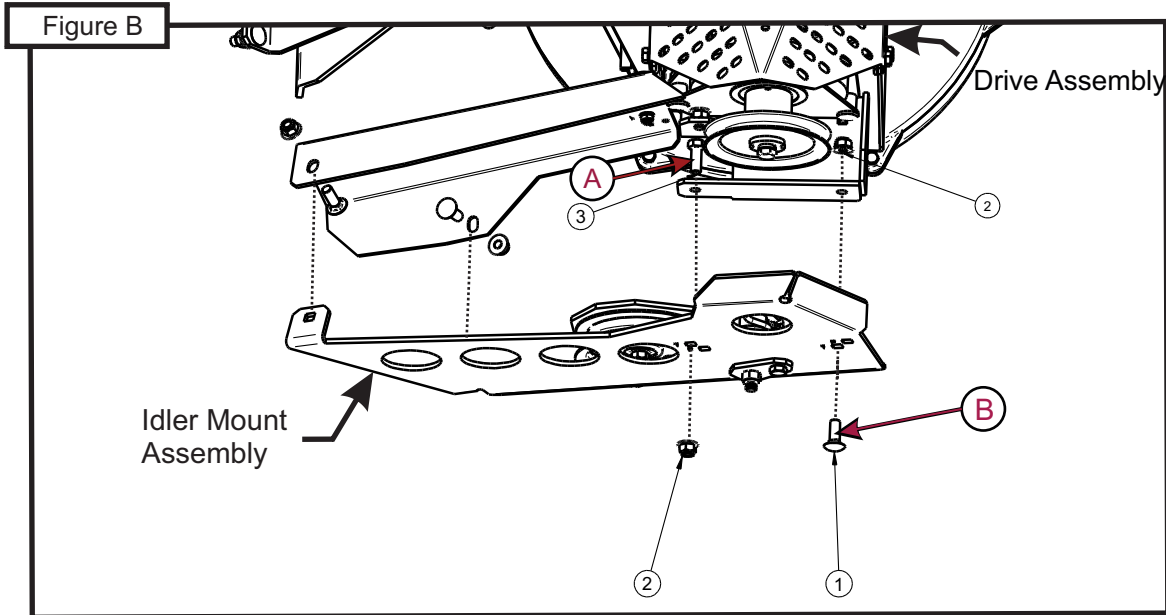


Item #	Part #	Desc.	Qty.
1	K1010	1/4"-20 x 5/8" Carriage Bolt	2
2	K2014	1/4"-20 Ny-Flange Lock Nut	2

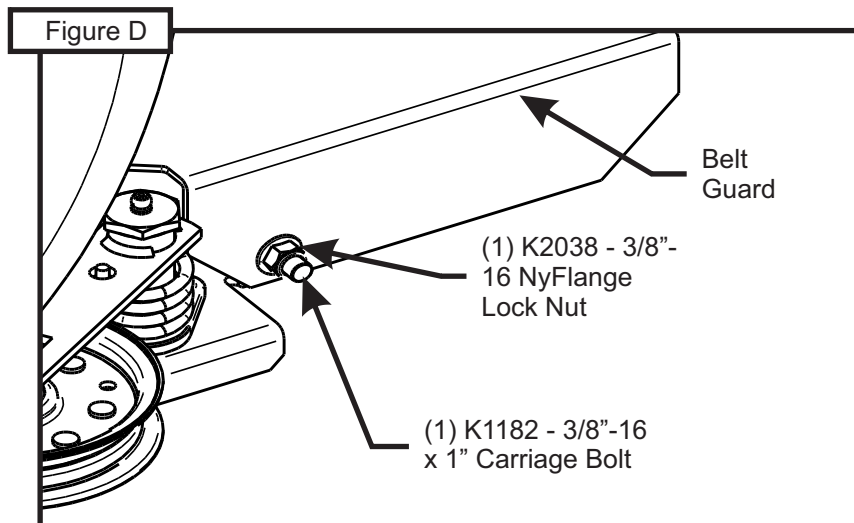
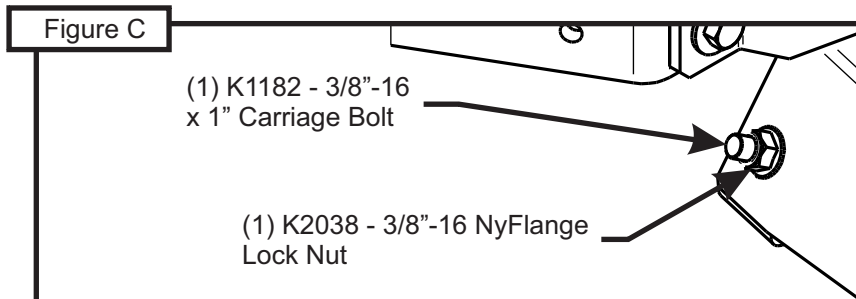
## PTO Drive Assembly (Continued)

Attach the Idler Mount Assembly P#(A2067\_02) to the Drive Assembly using (1) 3/8"-16 x 1" HHCS (A) P#(K1191), (1) 3/8"-16 x 1" Carriage Bolt (B) P#(K1182) and (2) 3/8"-16 Ny-Flange Lock Nuts P#(K2038). Refer to Figure B. Leave Bolts Loose (Note: Orientation of bolts A & B.)

Next, secure the Idler Mount Assembly P#(A2067\_02) to the Belt Guard Assembly P#(A2069\_02) using (2) 3/8"-16 x 1" Carriage Bolts P#(K1182) and (2) 3/8"-16 Ny-Flange Lock Nuts P#(K2038). Refer to Figure C & D. Tighten All Bolts.



Item #	Part #	Desc.	Qty.
1	K1182	Carriage Bolt 3/8"-16 x 1"	1
2	K2038	Ny-Flange Lock Nut 3/8"-16	2
3	K1191	HHCS 3/8"-16 x 1" GR5	1

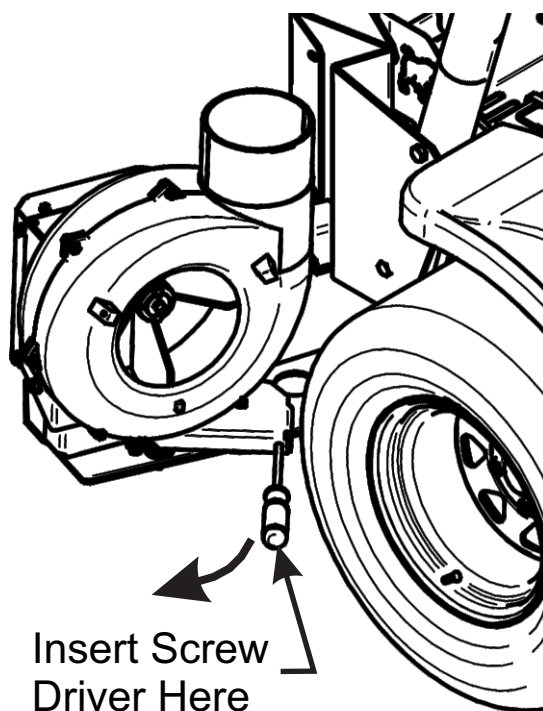
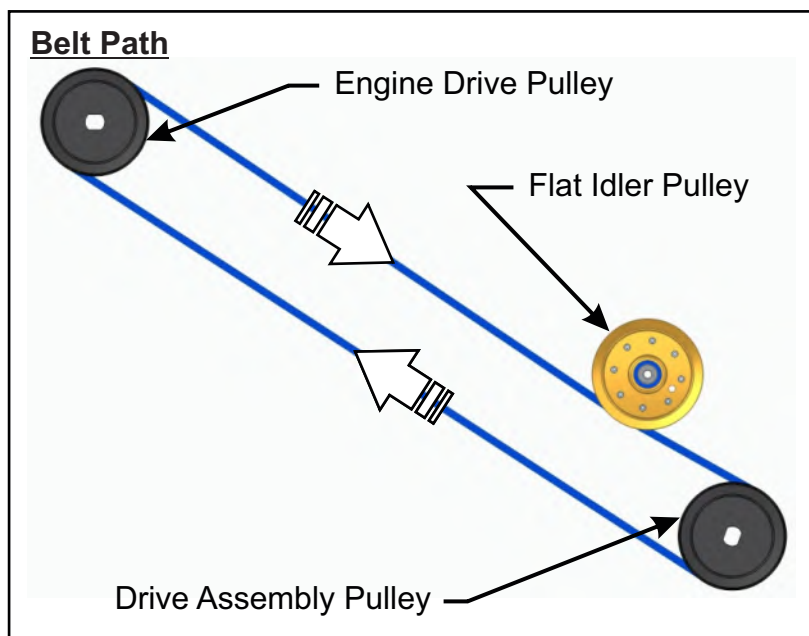
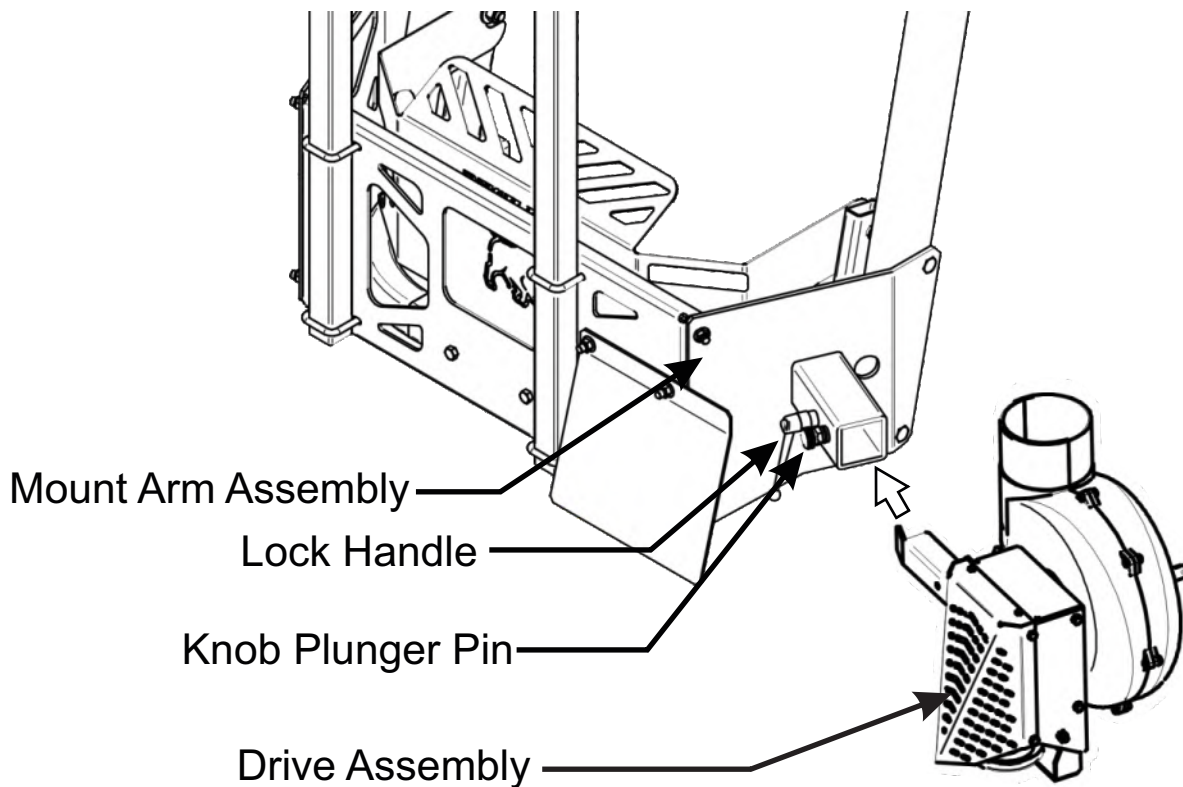


## Drive Assembly and Belt Installation

(Note: It is recommended that someone assist during this step.)

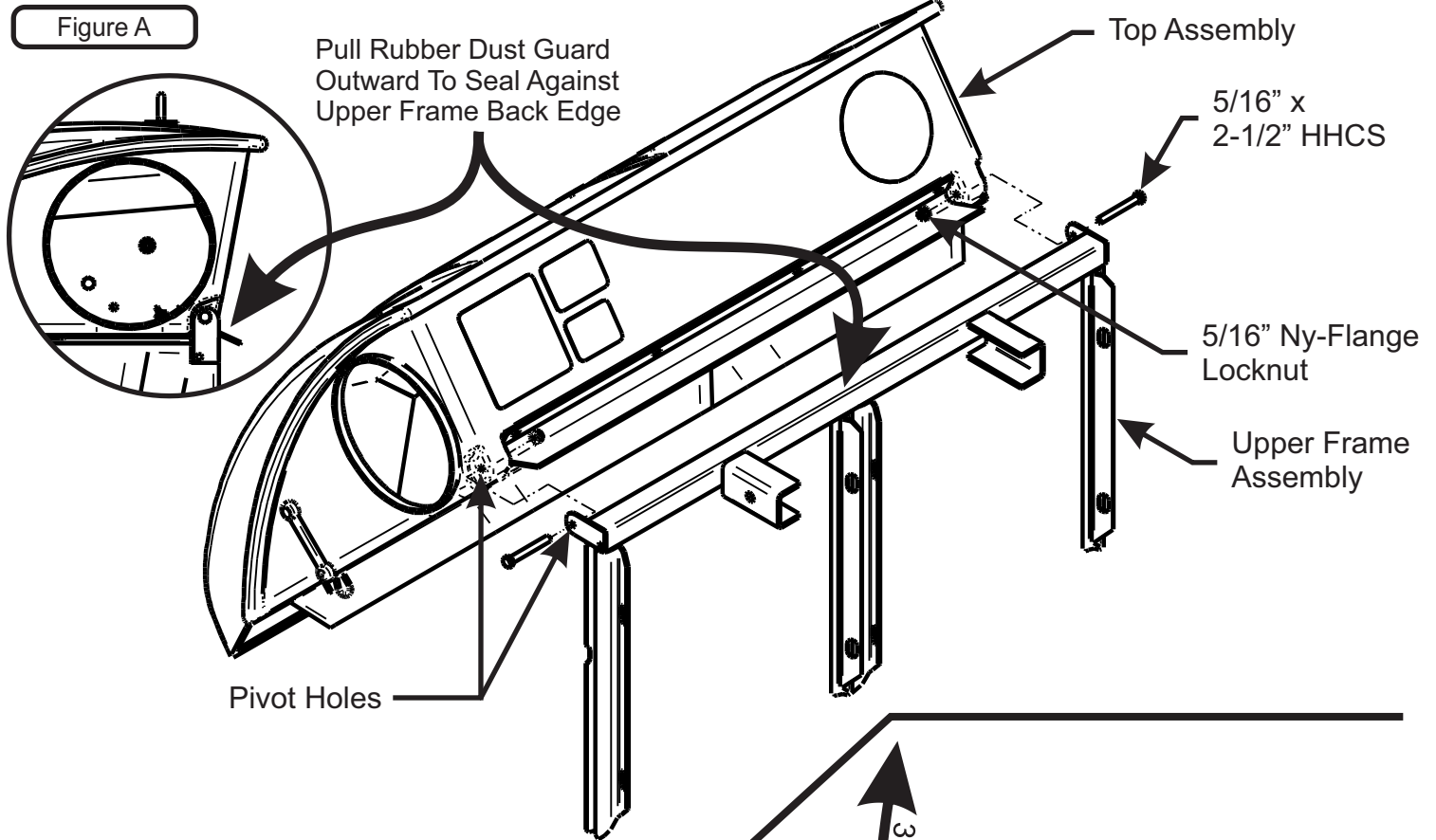
Insert the Drive Assembly into the receiver tube on the Mount Arm Assembly until the Knob Plunger Pin engages. Once in place, turn Lock Handle clockwise until tight. Next, feed the AK83 Belt P#(M0315) between the Belt Guard and the Idler Mount Assembly. Place belt around the Engine Drive Pulley on the underside of the mower. While one person inserts a screw driver (or similar tool) into the Idler Mount Assembly and rotates lever arm clockwise, enough to relieve all tension from belt, place belt around the Drive Assembly Pulley. Once the belt is in position, carefully release the tension to tighten belt.

Refer to the images below.



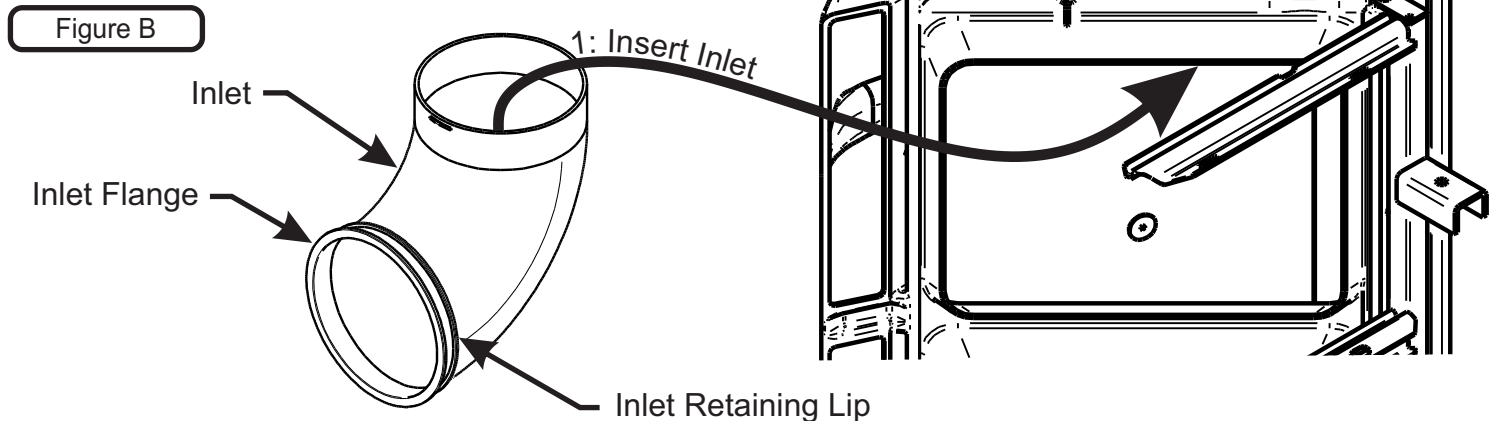
## Top Assembly To Upper Frame Assembly Installation

Align the Top Assembly Pivot Holes to the Upper Frame Assembly. See Figure A below. Before fastening, pull Rubber Dust Guard outward to seal against Upper Frame Assembly (towards the mower's operator seat). Fasten the Top Assembly to the Upper Frame Assembly using (2) 5/16"-18 x 2-1/2" HHCS P#(K0125) and (2) 5/16"-18 Ny-Flange Locknuts P#(K2516). Leave the Ny-Flange Locknuts slightly loose to allow the Top Assembly to open and close easily.



## Inlet Installation

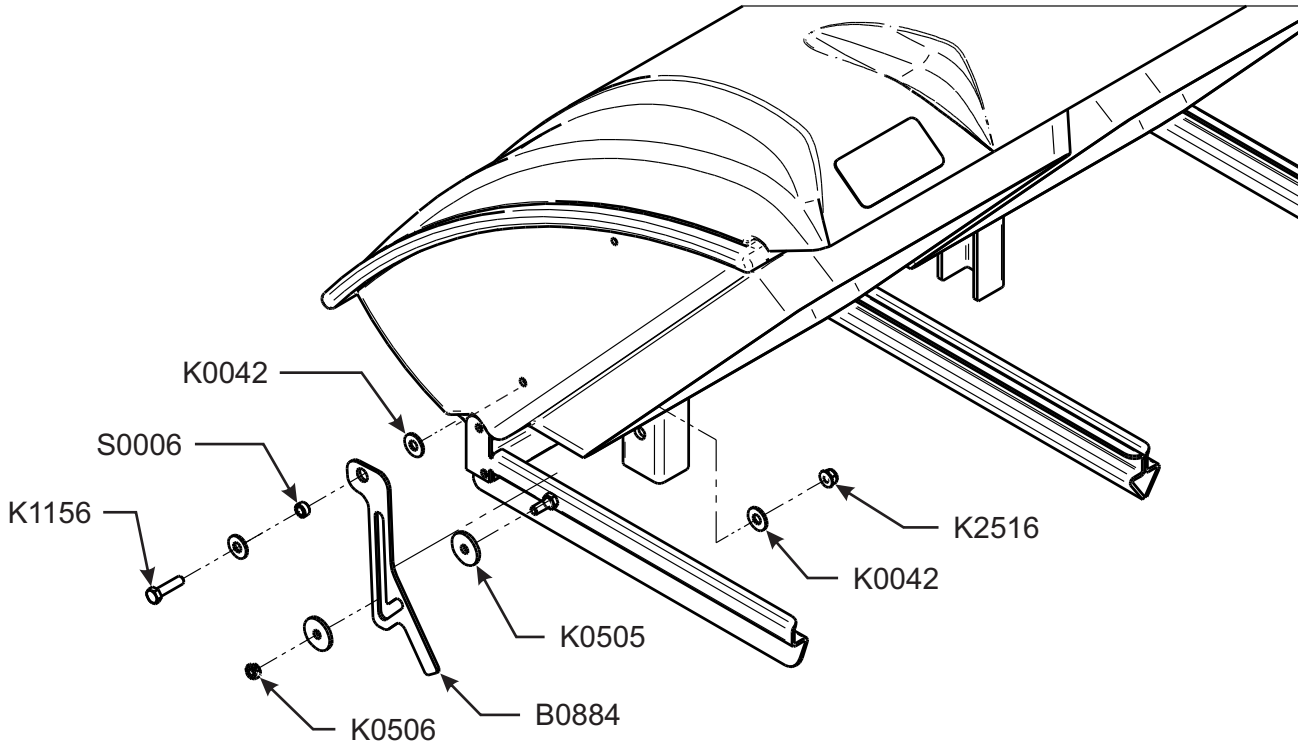
Position the Top Assembly on its side with the Inlet Hole facing up. See Figure B. 1: Insert the Inlet from inside the Top Assembly, up through the Inlet Hole, until the Inlet Retaining Lip meets the Inlet Hole. 2: Position the Inlet as shown in Figure B, then pull the Inlet until a portion of the Inlet Retaining Lip protrudes from the Inlet hole. 3: Next, lift the Inlet as shown in Figure B until all of the Inlet Retaining Lip protrudes from the Inlet Hole. Once installed, the Inlet should pivot freely about the Inlet Hole.





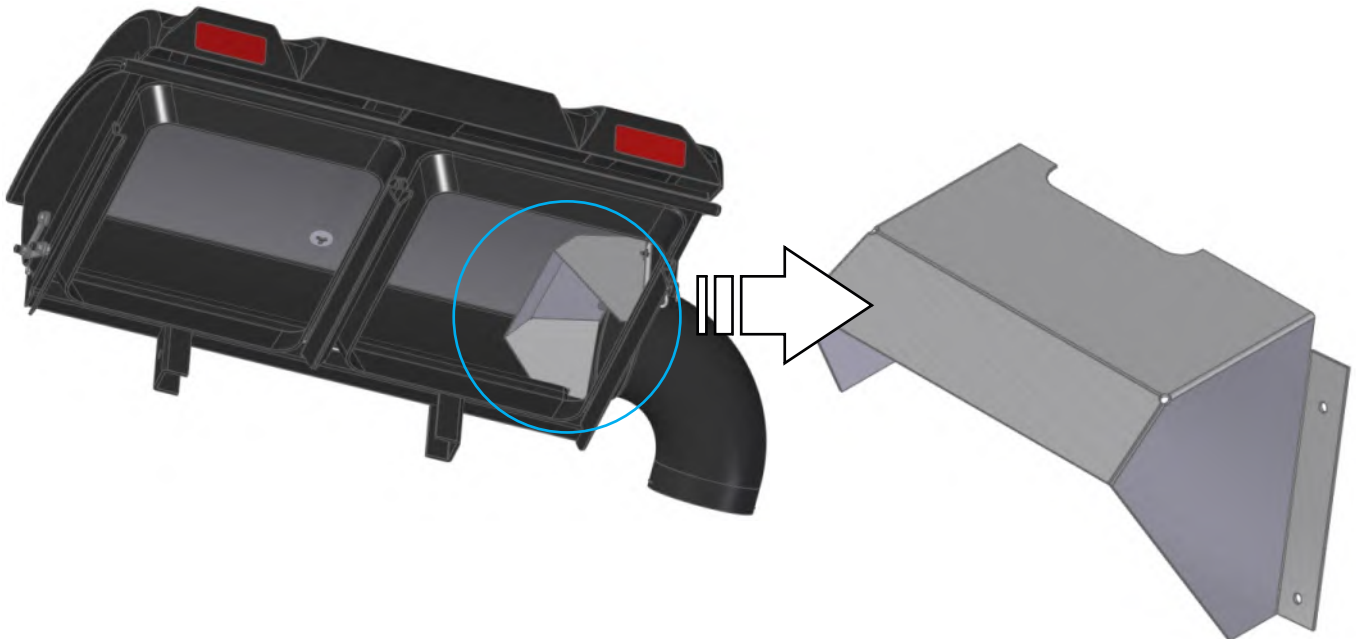
## Hinge Kit Assembly Installation

Assemble the Hinge Kit using (1) Latch Plate P#(B0884), (1) 5/16"-18 x 1-1/4" HHCS P#(K1156), (1) 5/16"-18 Ny-Flange Lock Nut P#(K2516), (3) 5/16" Flat Washers P#(K0042), (1) Latch Spacer P#(S0006), (2) Extra Heavy 5/16" Fender Washers P#(K0505) and (1) 5/16"-18 Lock Nut P#(K0506). Leave the nuts loose enough to allow fluid movement of the top when opening and closing. When opened, the top should rest in the Latch Plate Slot.



## Even Bag Fill Adjustment

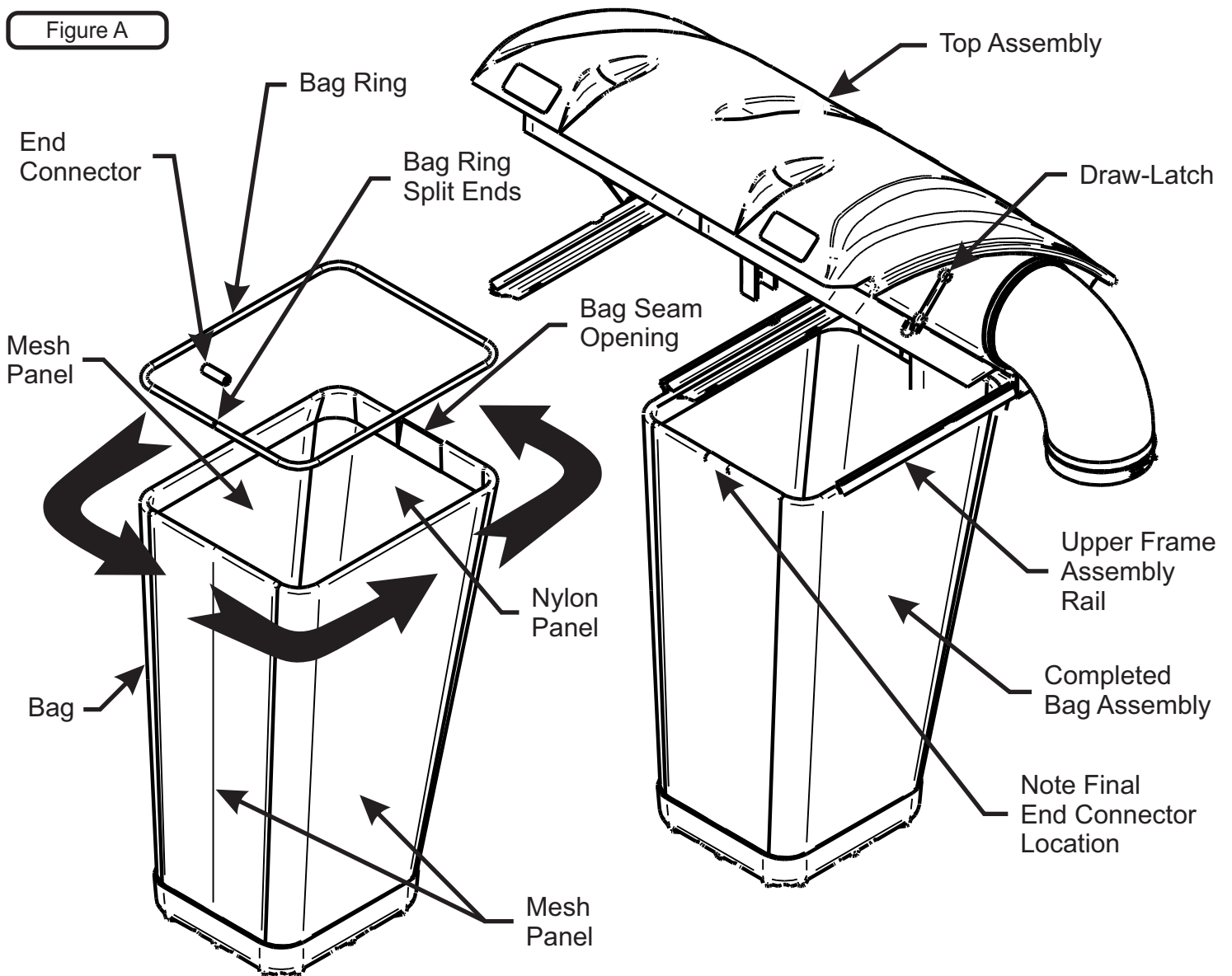
Flap can be adjusted Up/Down depending on mowing conditions. Adjust flap up to allow more dense material to reach left bag. Adjust flap down to allow less dense material to reach the right bag. Once adjusted properly, both bags should fill evenly, but may require further adjusting when mowing conditions change.



## **Bag Assembly**

First, take one of the Bag Ring Split Ends and insert it through the Bag Seam Opening. Next, rotate the Bag around the Bag Ring (1) full turn (360 degrees) until the Bag Ring Split Ends and the Bag Seam Opening are positioned on the same side. Then, connect the Bag Ring Split Ends using (1) End Connector. Last, rotate the Bag Ring and the End Connector Assembly (1/2") turn (180 degrees) to position the Connector opposite of the Bag Seam Opening. Note Final End Connector Location below in Figure A. Repeat for each Bag.

Figure A

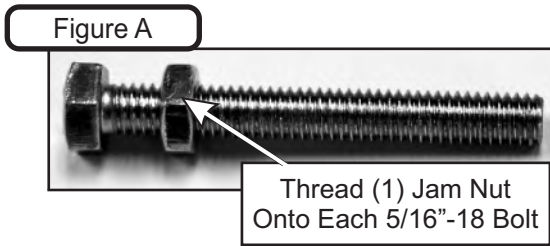


## **Bag Assembly Installation**

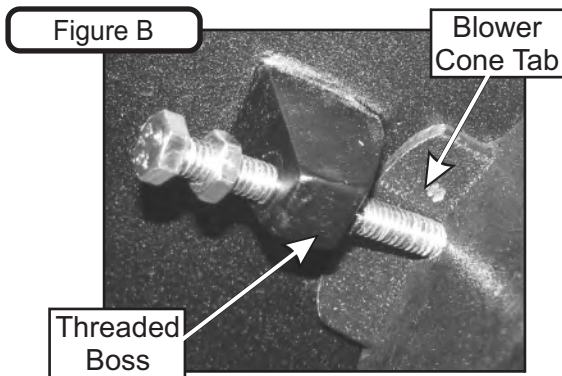
Slide the Completed Bag Assembly into the Upper Frame Assembly Rails and close the Top Assembly. Fasten the Draw-Latch on either side to hold the bagger closed.

## Blower Cone Installation

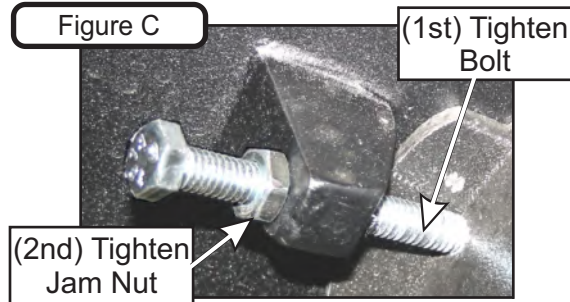
Thread (1) 5/16"-18 Jam Nut P#(K0120) onto each end of (2) 5/16"-18 x 2-1/2" HHCS P#(K0125) as shown in Figure A.



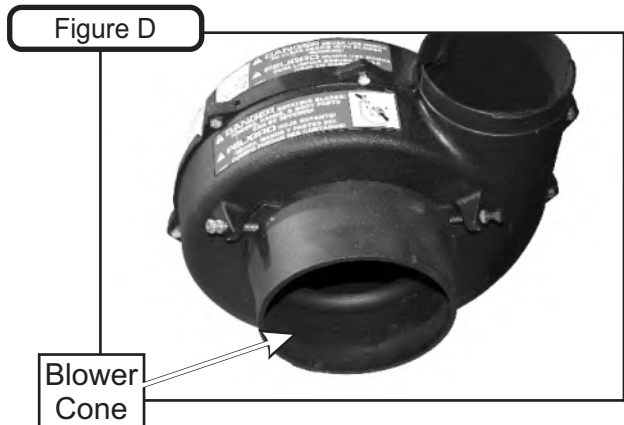
Now partially thread (1) bolt into each of the two threaded bosses located on the Blower Housing. Place 8" Blower Cone P#(E6009) so the two tabs line up with the bolts and tighten completely as shown in Figure B.



Once the (2) bolts are tight, tighten the Jam Nuts against the threaded boss as shown in Figure C.

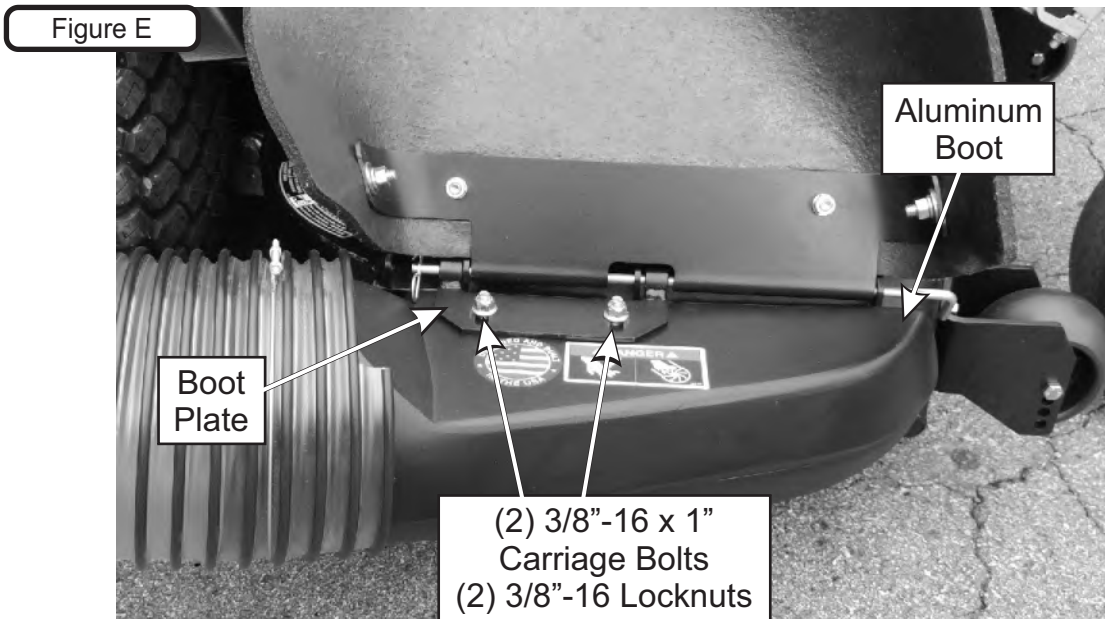


Refer to Figure D for proper Blower Cone installation reference.



## Boot Kit Installation

Secure the Boot Plate P#(A2129) to the Aluminum Boot P#(E0034A) using (2) 3/8"-16 x 1" carriage bolts P#(K1182) and (2) 3/8"-16 nylon flange locknuts P#(K2038). Insert the bolts from the inside so that the threads are on top of the boot. This will prevent grass clippings from collecting on the bolt threads. Leave the hardware loose until the boot assembly has been attached to the mower deck. Lift the grass deflector and slide the boot plate under the grass deflector rod. Close any gaps between the boot and the mower deck by adjusting the position on the boot in the boot plate slots. Tighten all hardware at this time. Refer to Figure E.

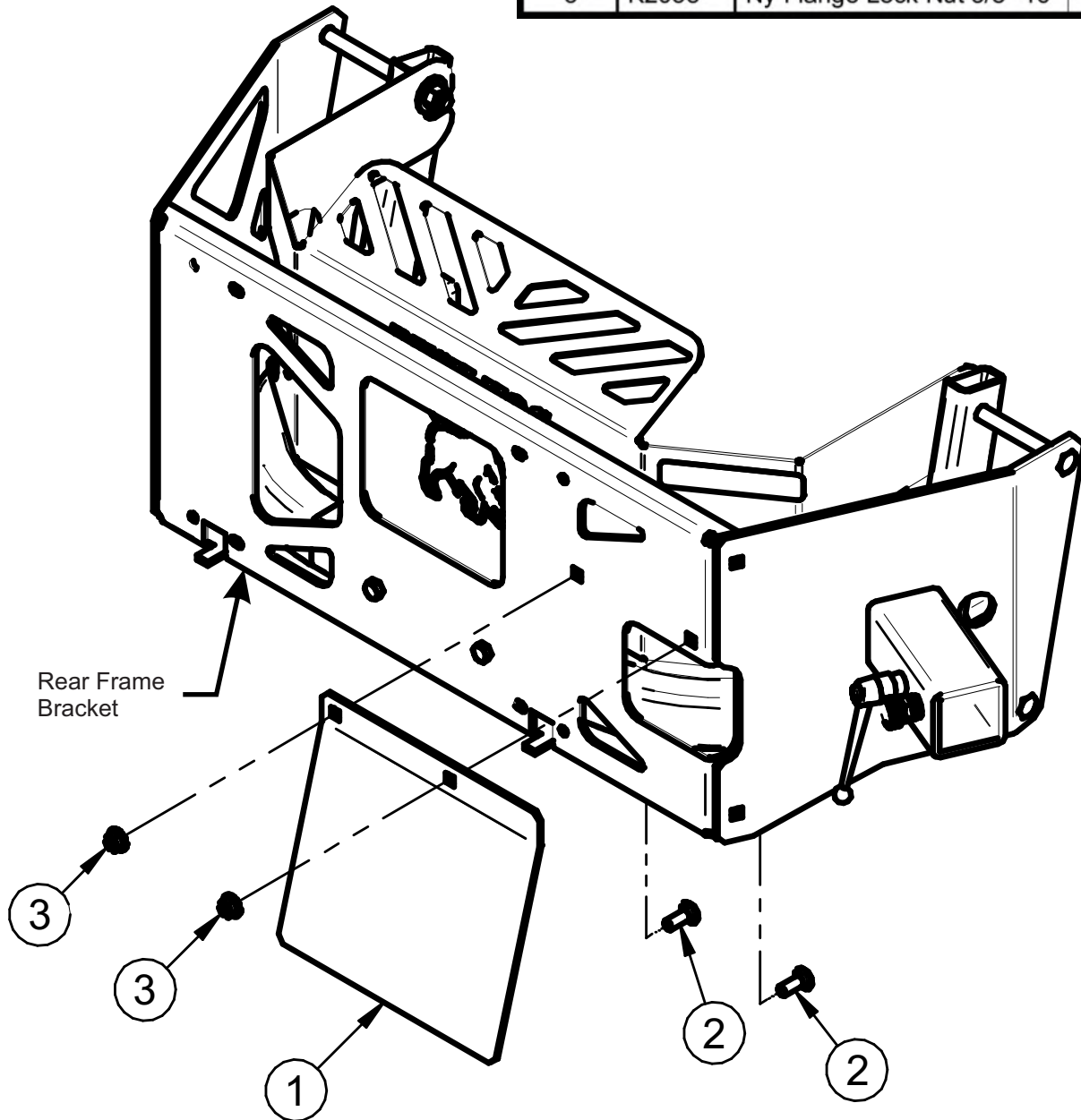


## Exhaust Guard Installation

An Exhaust Guard would need to be installed on your PTO Rear Frame Bracket to prevent the exhaust from damaging the collection bags.

To install the Exhaust Guard, align the (2) bolt holes to those on the right side of the Rear Frame Bracket. Secure the Exhaust Guard by using (2) 3/8"-16 x 1" Carriage Bolts and (2) 3/8" Ny-Flange Lock Nut. Refer to the figure below.

Item #	Part #	Desc.	Qty.
1	C0092	Exhaust Guard	1
2	K1182	Carriage Bolt 3/8"-16 x 1"	2
3	K2038	Ny-Flange Lock Nut 3/8"-16	2



## Length Of Hose Adjustment

The hoses in the following steps must be cut to fit your machine. Do not cut the hoses until you have tried to fit them on your machine. Remember that the hoses need to be long enough to allow for the opening and closing of the collection system as well as allowing ample clamping surface between each component.

## Upper Hose Installation

Slide a Hose Clamp P#(J0060) over one end of the 6" Upper Hose. Secure this end of the 6" Upper Hose to the Blower Outlet. See Figure below for details. Secure opposite end of the 6" Upper Hose to the Inlet. Make sure both ends are securely fastened by tightening the Hose Clamp and rotating the Inlet Snap Fastener towards the hose to lock in place.

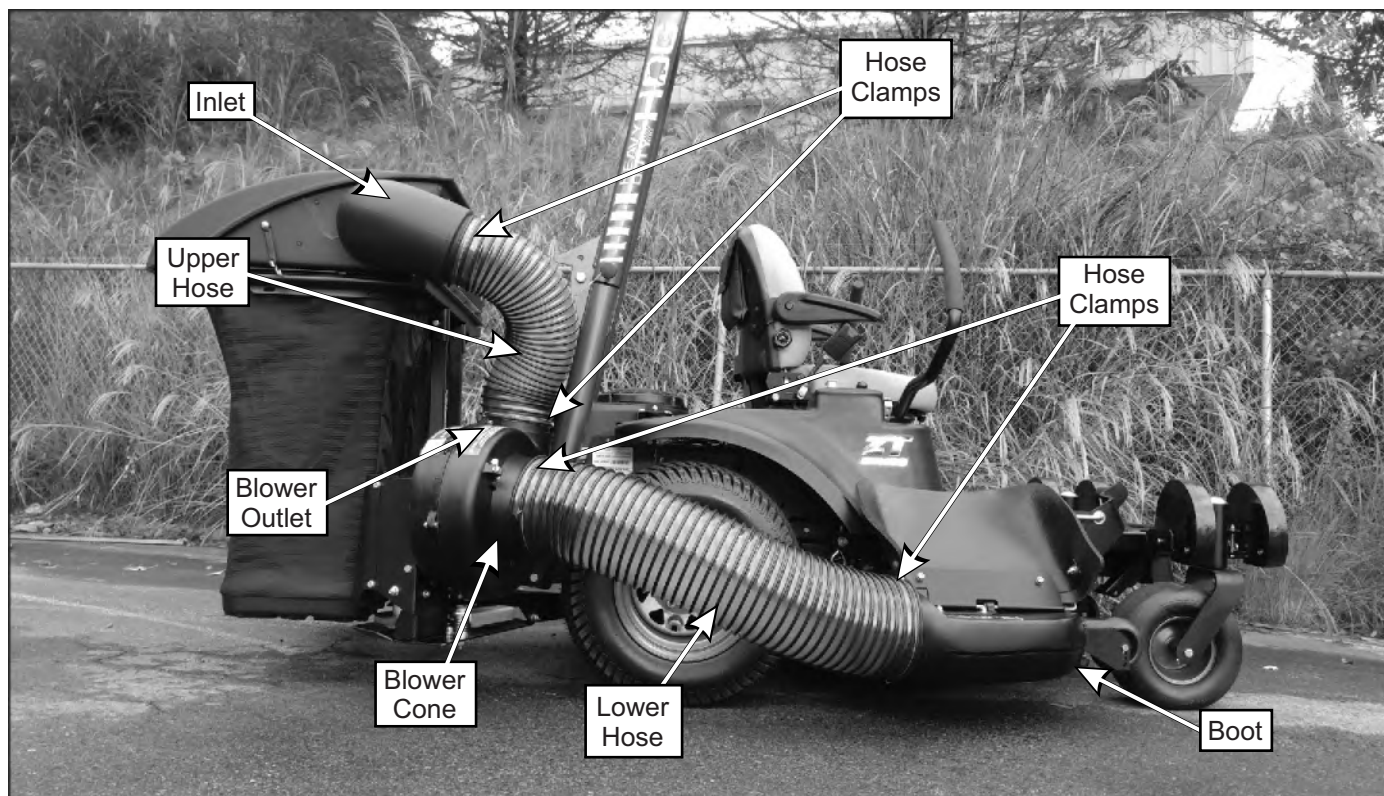
## Lower Hose To Blower Cone Installation

Slide a Hose Clamp P#(J0060) over both ends of the Lower Hose. Secure one end of the Lower Hose to the Blower Cone and fasten by tightening the Hose Clamp.

## Lower Hose To Boot Installation

Take the unattached end of the Lower Hose and secure it to the circular end of the Boot and fasten by tightening the Hose Clamp.

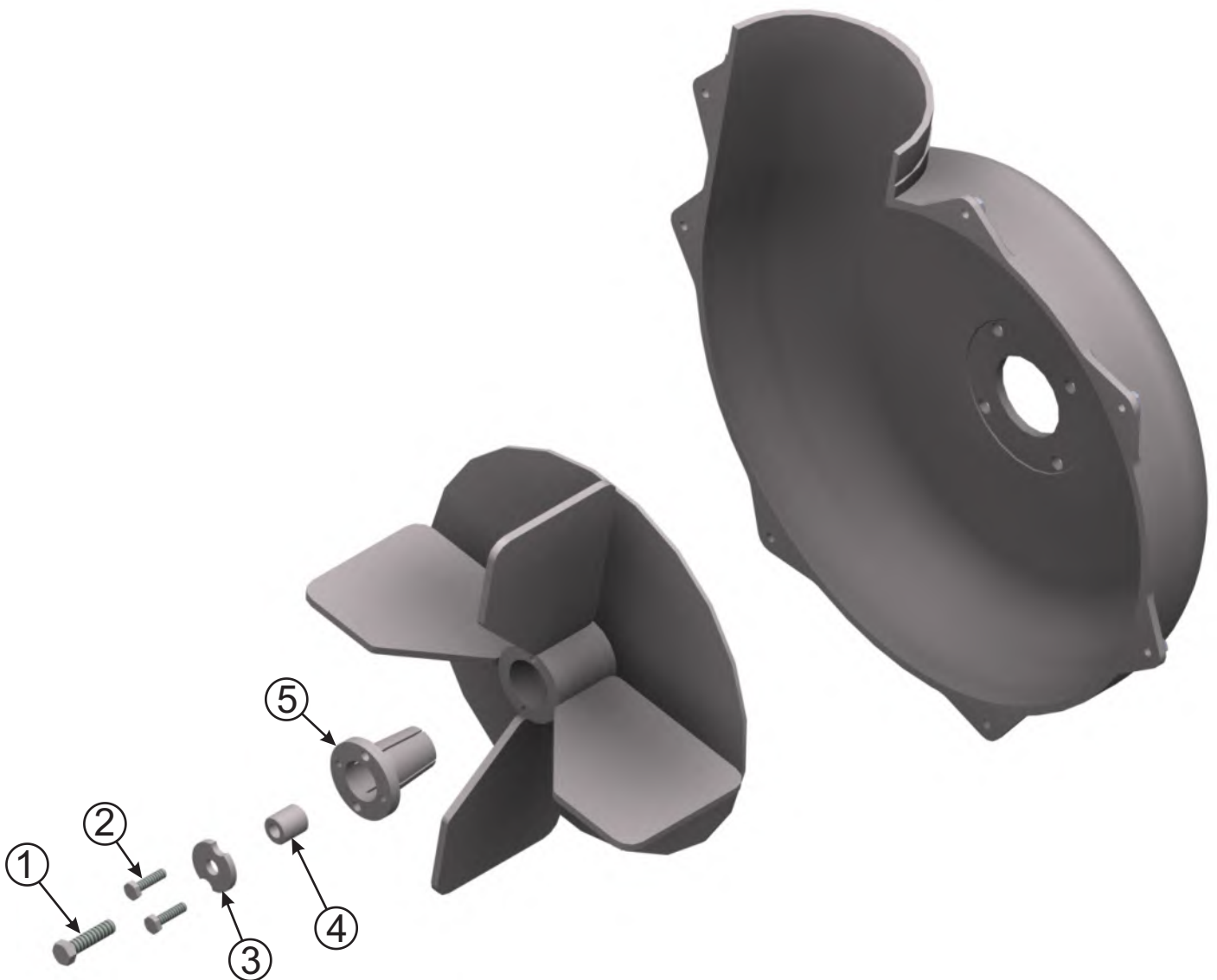
Tip: Before securing Hose Clamp fully, rotate Lower Hose counter-clockwise (away from yourself) approximately 1" to aid in retaining Boot to mower deck.



## Impeller Blade Removal/Replacement

**To Remove:** First remove the 5/16"-24 x 1" HHCS P#(K0428) (#1), Taper Lock Bushing Washer P#(K0284) (#3), (2) 5/16 Flat Wahers P#(K0042) and Spacer Bushing P#(S0159) (#4) from the Taper-Lock Bushing P#(S0157) (#5). Next remove the (2) 1/4"-20 x 1" HHCS (#2) and place them into the threaded holes of the Taper-Lock Bushing (#5). Gradually thread each bolt evenly into the Taper-Lock Bushing, forcing the blade to break-away from the Taper-Lock Bushing. If the Impeller will not move, carefully hit the base of the Impeller, between each vein, with a hammer, then try again.

**To Replace:** Place Impeller Blade over the engine shaft. Slide the Taper-Lock Bushing (#5) on to the engine shaft and into the Impeller Blade, aligning the **non-threaded** holes of the Taper-Lock Bushing to the threaded holes of the Impeller Blade. Fasten by using (2) 1/4"-20 x 1" HHCS (#2), (1) Spacer Bushing (#4) (1) Taper-Lock Bushing Washer (#3), and (1) 5/16"-24 x 1" HHCS (#1). Torque to the proper specifications in the torque chart on the back of this manual. Next, rotate the Impeller Blade to ensure that the blade is clear of contact on all sides of the blower housing.



## Wire Harness Installation

### **WARNING**

**To Prevent Serious Injury- Proper Installation Of Safety Interlock Harness Is Mandatory. Please Check That All Interlock Points Work Correctly Once Installed.**

Route the 2 Way Metri-Pack Connector (P#P0280) around the front side of the engine, between the ROPS and the engine through the opening in the rear bumper connecting to the Quick Connect Plug (#1) located on the PTO Drive. Refer to Figure A.

Attach the Positive Lead from the Wiring Harness (P#A2144) connected to the Metri-Pack 2 Way Connector (P#P0280) to the PTO Switch (P#J2001) by connecting the Female Disconnecter (P# P0106) from the Positive Lead to the Switch Terminal (A) on the Switch. Refer to Figure B on the next page.

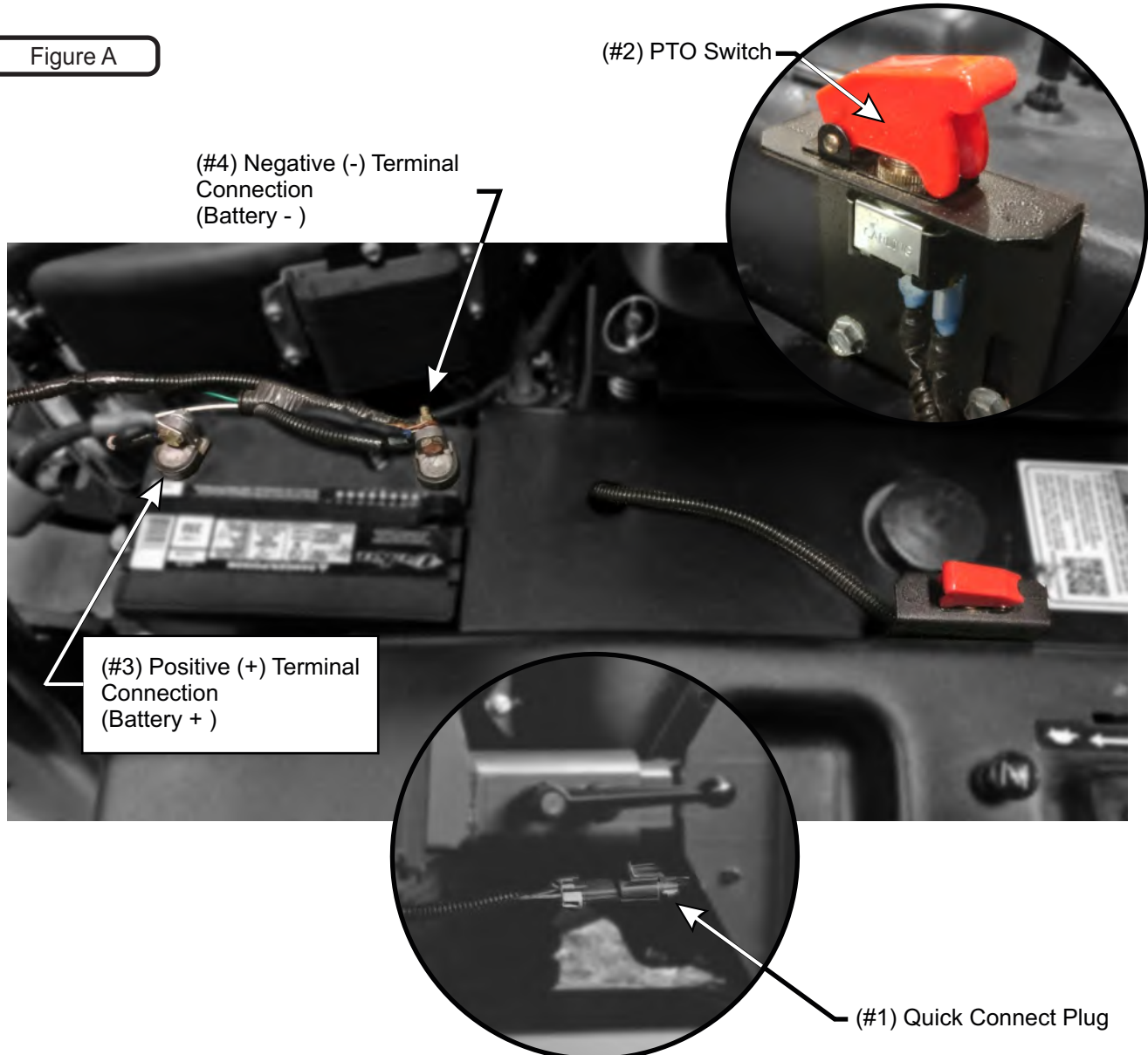
Insert the PTO Switch in and through the PTO Switch Bracket (P#B1020) then attach and secure the Safety Cover (P#P0073).

Before routing the PTO Switch (#2), determine where on the right mower side panel the PTO Switch should be attached. It is recommended to attach the PTO Switch close to the control panel of the mower for ease of access. To attach the PTO Switch, pre tap two holes for the (2) 1/4"-20 x 1/2" Slotted Indented Hex Washer Head Screws that are provided. Attach the PTO Switch Bracket by sliding it behind the (2) Slotted Indented Hex Washer Head Screws and tightening the hardware. Refer to Figure A.

Route the PTO Switch to the positive terminal of the battery (#3) using the Ring Terminal (P#P0086) of the Positive Lead to secure the attachment. Route the Negative Lead to the negative terminal of the battery (#4) using the Ring Terminal of the Negative Lead to secure the attachment. Refer to Figure A.

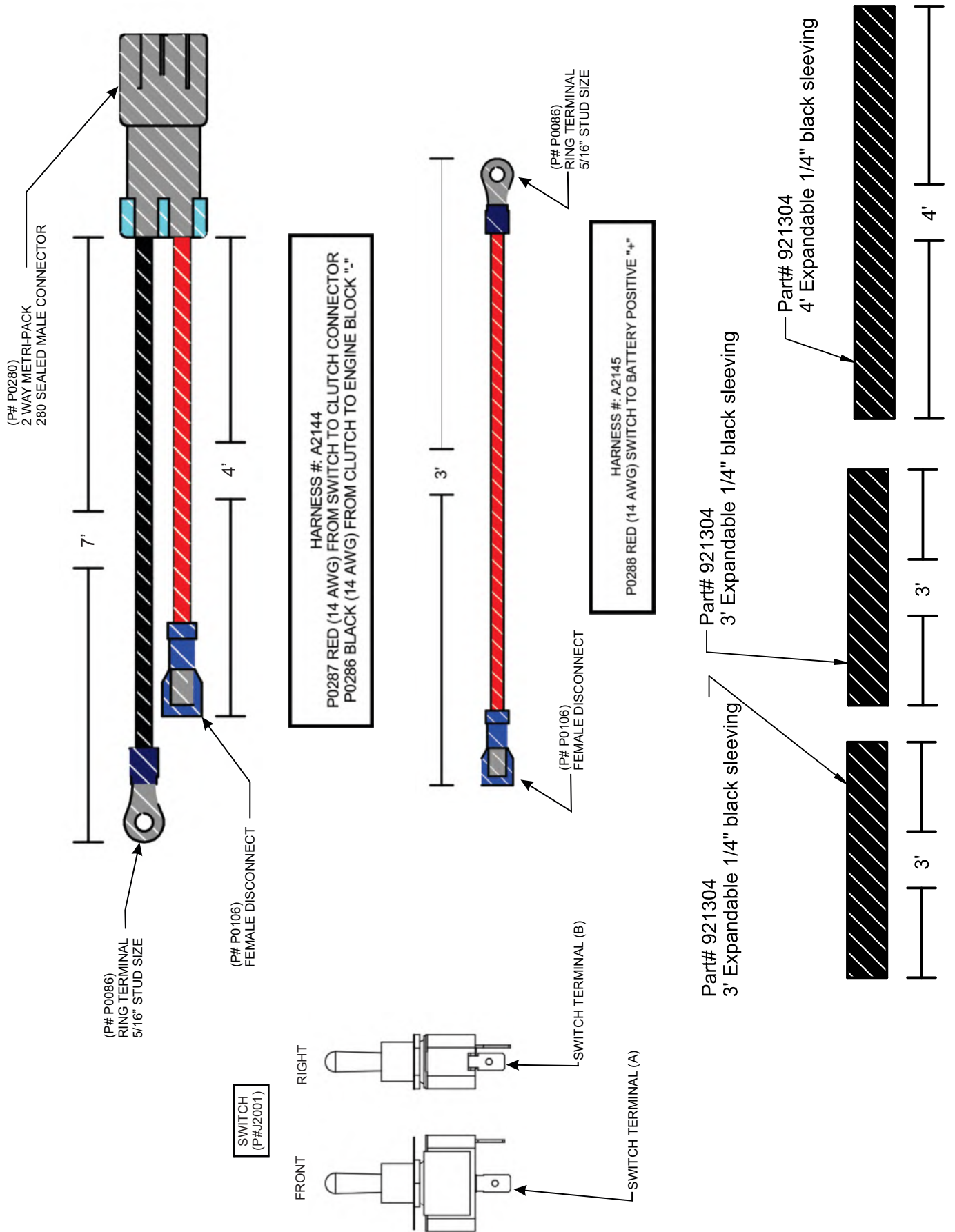
Use the Cable Ties (P#J0245) that are provided to secure the wires in place.

Figure A



# Wire Harness Installation (Continued)

Figure B





## Weight Kit Installation

Position the Dual Weight Bracket Base (Item#1) under the caster tubing w/ opening towards caster fork. Next, position the Weight Bracket Clamp (Item#2) on top of caster tubing w/ opening towards caster fork.

Align the (4) holes of the Weight Bracket Clamp (Item#2) to the holes in the Dual Weight Bracket Base (Item#1). Loosely fasten the Weight Bracket Clamp (Item#2) to the Weight Bracket Base (Item#1) using (4) 5/16"-18 x 3" Bolts (Item#4) & (4) 5/16"-18 Ny-Flange Lock Nuts (Item#5).

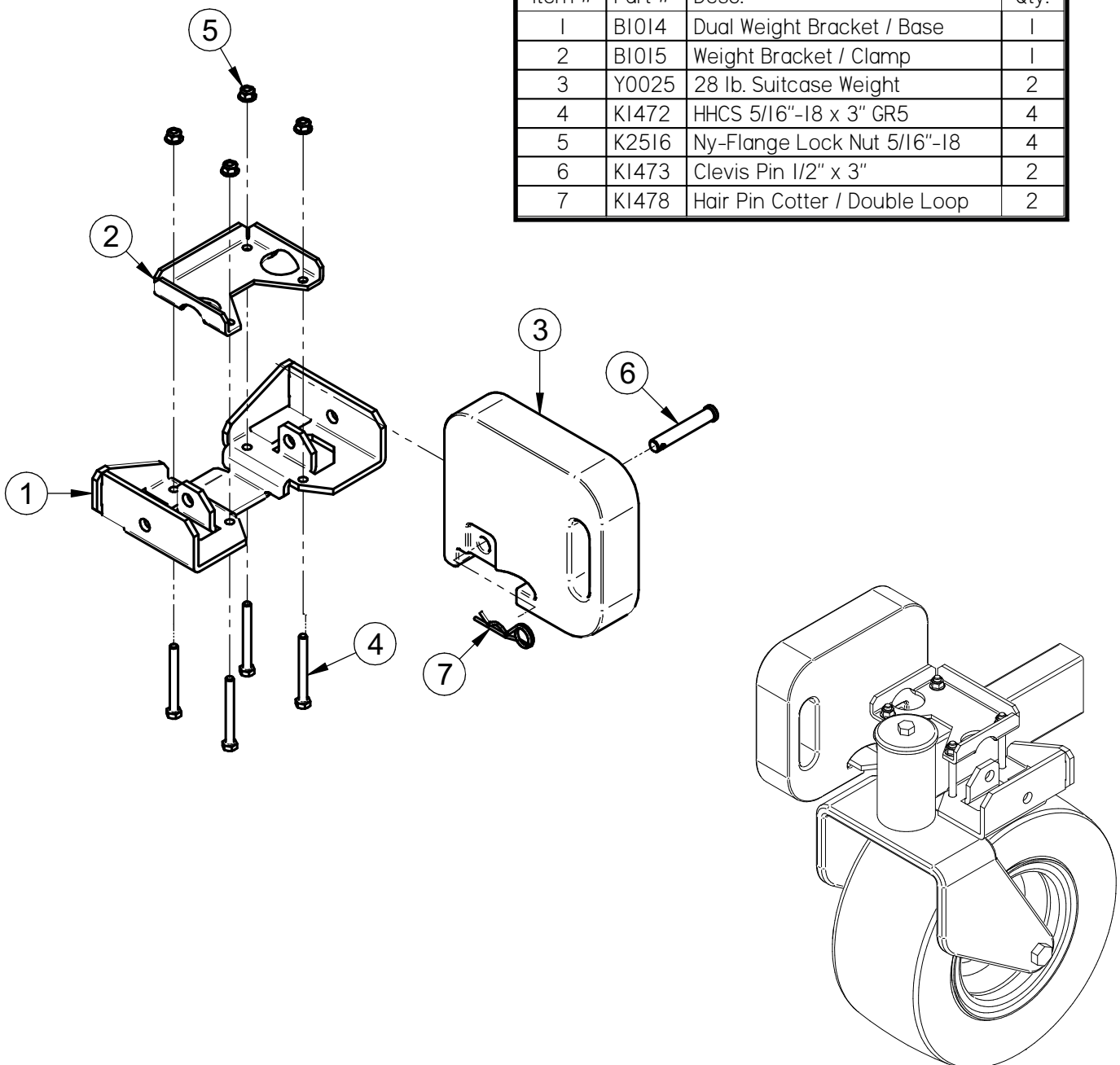
Position the Weight Bracket Base and the Weight Bracket Clamp assembly along the caster tubing to prevent interference from caster forks or any other objects. Tighten the fasteners in an 'X' pattern until assembly is firmly clamped to caster tubing. Do not over tighten which may result in bending Weight Bracket Clamps (Item#3).

Insert (1) Weight (Item#3) Into the Weight Bracket Base (Item#2) & align the holes of the Weight w/ the holes of the Weight Bracket Base (Item#2). Fasten the Weight (Item#1) to the Weight Bracket Base Using (1) Clevis Pin (Item#6) & (1) Hair Pin Clip (Item#7) per weight.

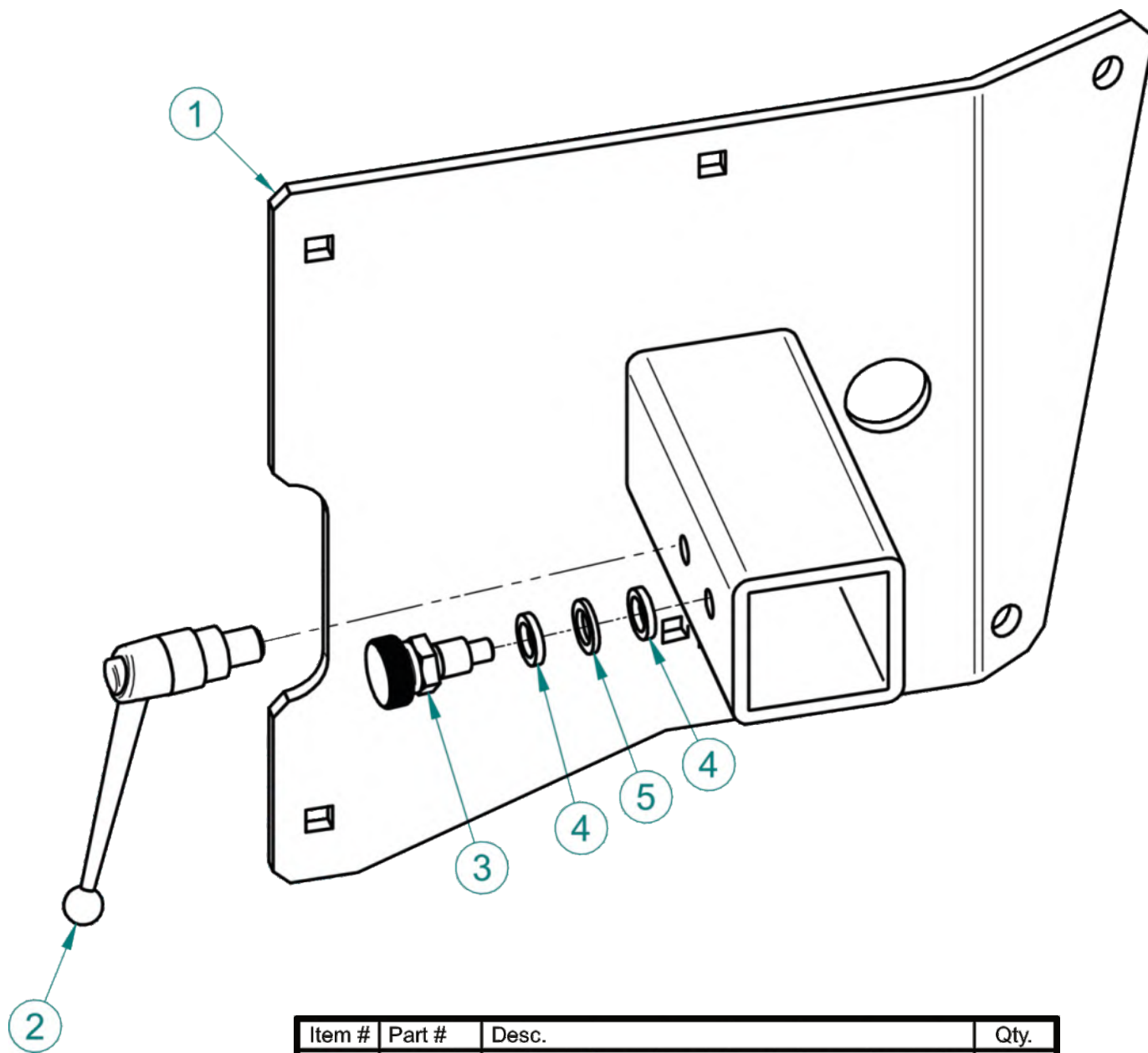
Repeat on additional caster. Refer to the Figure Below.

Figure A

Item #	Part #	Desc.	Qty.
1	BI014	Dual Weight Bracket / Base	1
2	BI015	Weight Bracket / Clamp	1
3	Y0025	28 lb. Suitcase Weight	2
4	K1472	HHCS 5/16"-18 x 3" GR5	4
5	K2516	Ny-Flange Lock Nut 5/16"-18	4
6	K1473	Clevis Pin 1/2" x 3"	2
7	K1478	Hair Pin Cotter / Double Loop	2

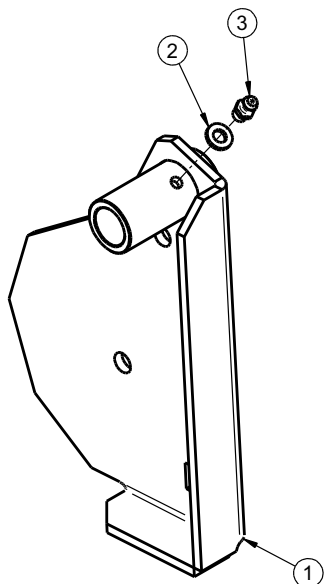


# A2138 Mount Arm Assy



Item #	Part #	Desc.	Qty.
1	A2137	Mount Arm Sub-Assembly	1
2	J0009	Adjustable Handle 1/2"-13 x .59 Male	1
3	J0020	Knob Plunger Pin 1/2"-13	1
4	J0013	Nylon Flat Washer 1/2" x .750" OD Grade 6/6	2
5	K0027	Flat Washer 1/2" / .787 OD x .512 ID x .090 T	1

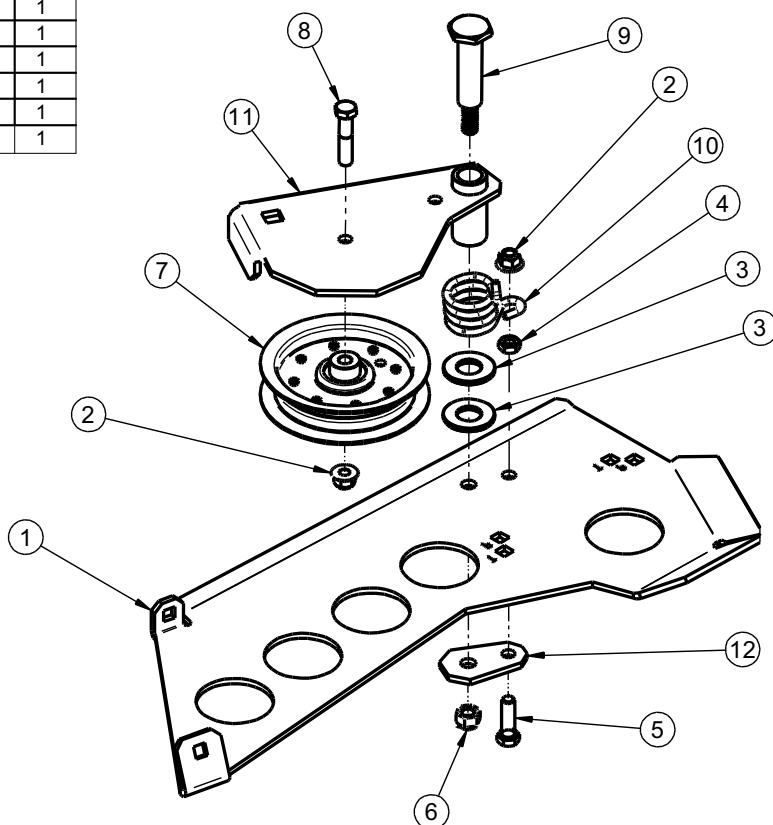
## A2092 Idler Arm Assembly



Item #	Part #	Desc.	Qty.
1	A2070_01	Idler Arm Weldment	1
2	K1467	Flat Washer M6 x 12mm OD	1
3	J0801	1/4"-28 Zirc Fitting	1

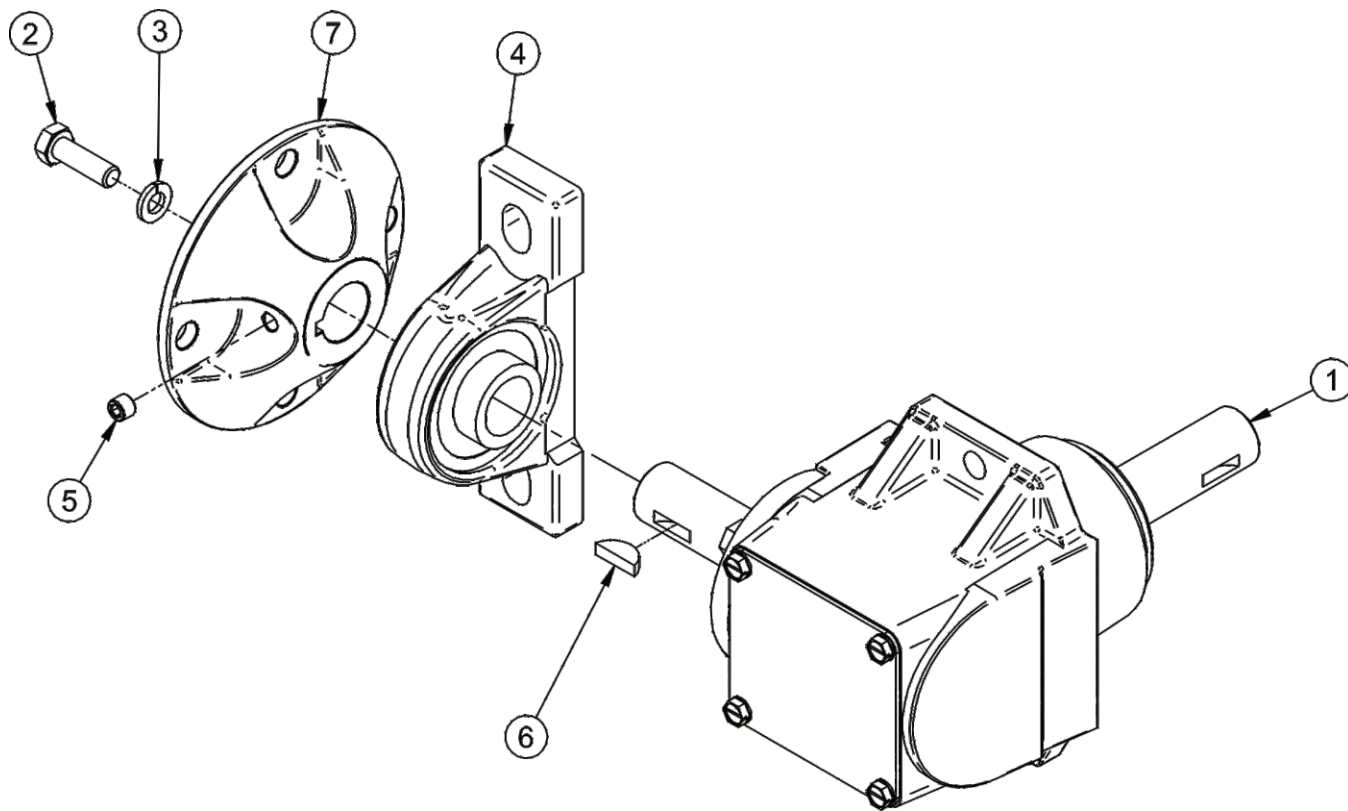
## A2067 02 Idler Mount Assembly

Item #	Part #	Desc.	Qty.
1	B0958_02	Idler Mnt Pl	1
2	K2038	Ny-Flange Lock Nut 3/8"-16	2
3	K1463	Flat Washer .720 ID x 1.500 OD x .250 T	2
4	K1219	Jam Nut 3/8"-16	1
5	K1192	HHCS 3/8"-16 x 1-1/4" GR5	1
6	K0329	Nylock Nut 7/16"-14 GR8	1
7	M0003	Idler Pulley	1
8	K1462	HHCS 3/8"-16 x 1-3/4" GR8	1
9	K1464	Shoulder Bolt 7/16"-14 / Idler	1
10	J0024	Torsion Spring	1
11	A2092	Idler Arm Assy	1
12	B0974	Idler Base Plate	1



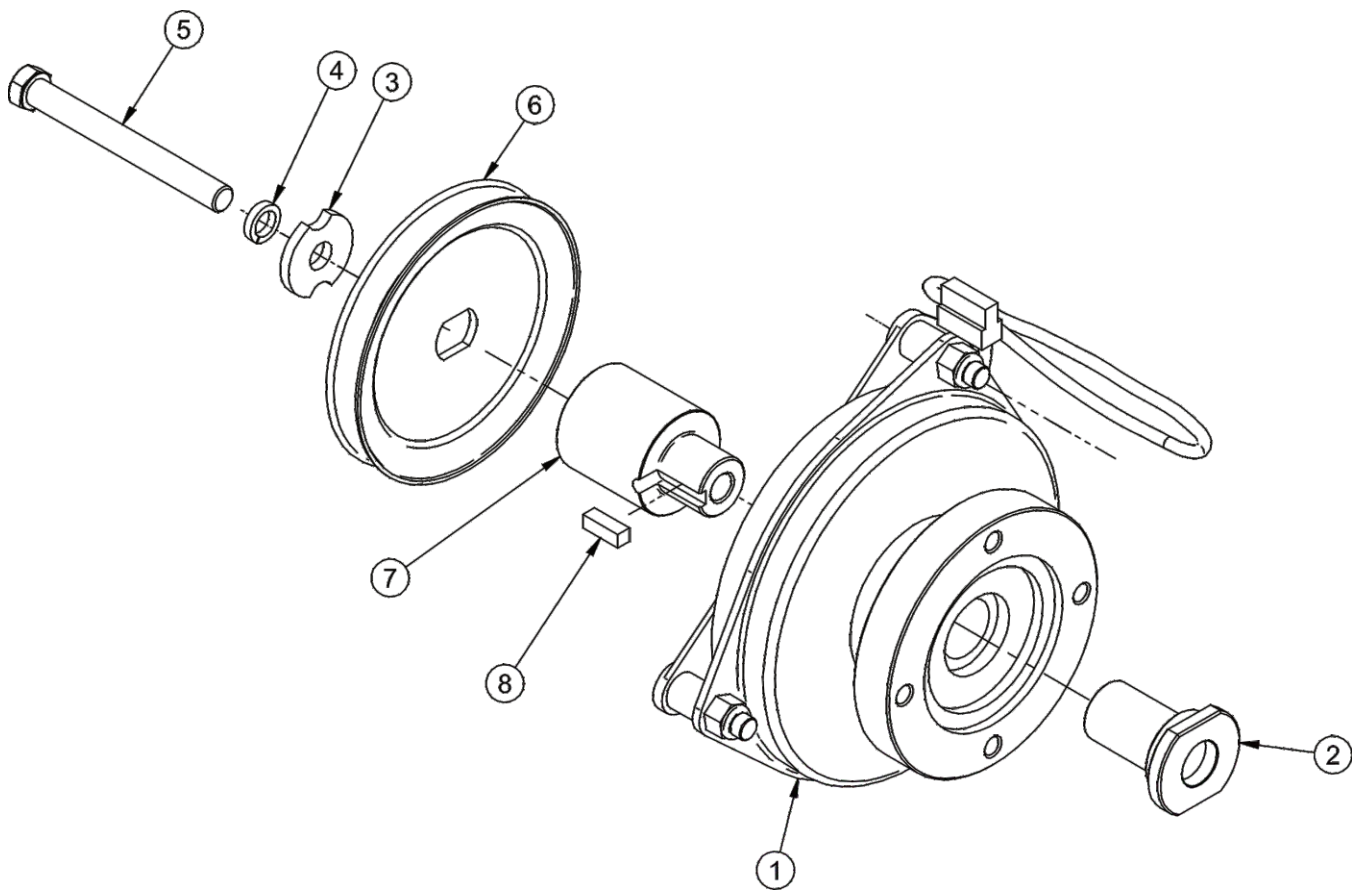
## A2058 Gearbox Sub-Assembly

Item #	Part #	Desc.	Qty.
1	M0002	Gearbox	1
2	K0428	HHCS 5/16"-24 x 1" GR8	1
3	K0043	Lock Washer 5/16"	1
4	N0002	Pillow Block Bearing 7/8"	1
5	K0035	Set Screw 5/16"-18 x 1/4" Cup Point	1
6	J0272	Woodruff Key #9	1
7	A2048	Clutch Flange	1



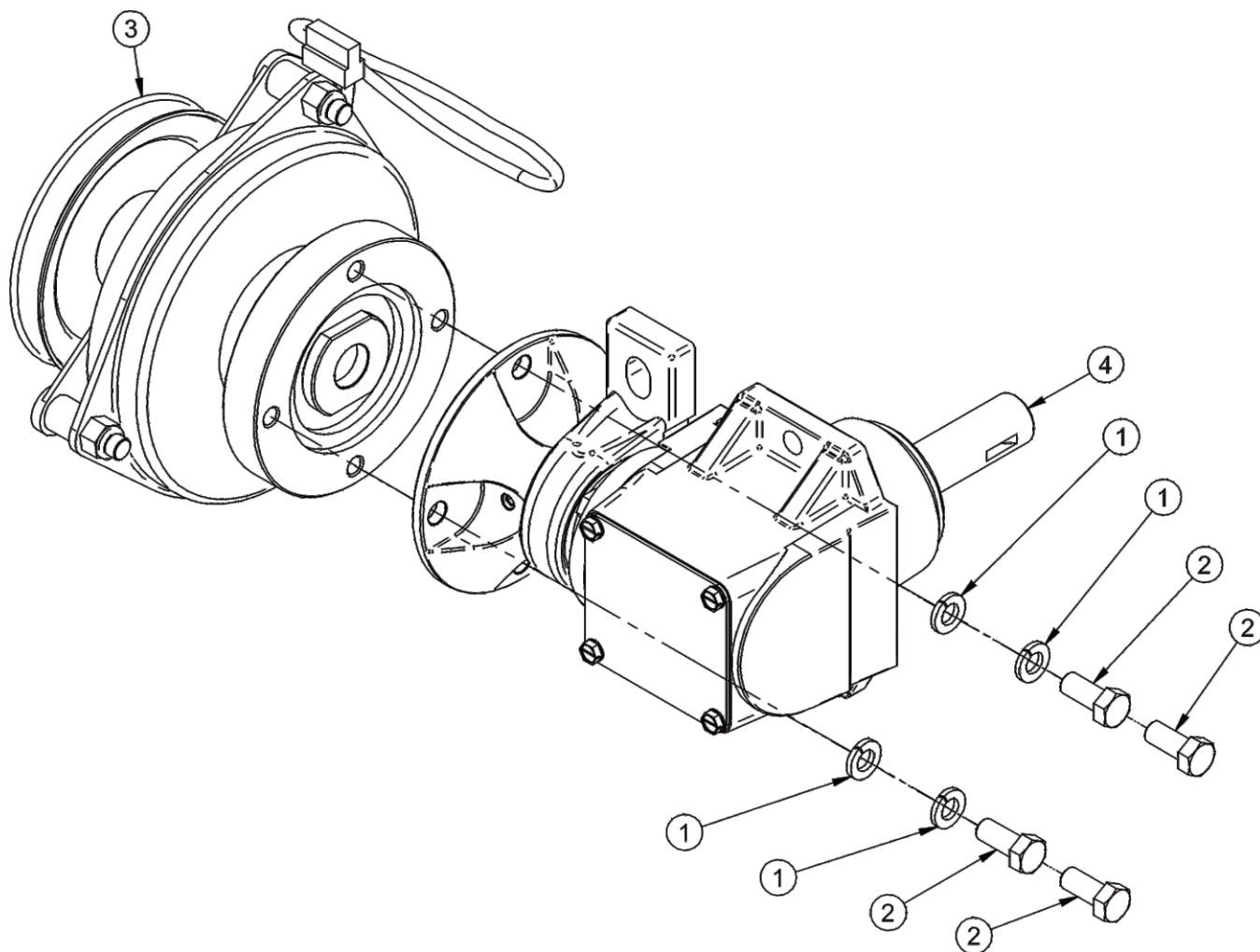
## A2059 01 Clutch Sub-Assembly

Item #	Part #	Desc.	Qty.
1	M0001	Electric Clutch	1
2	S0007	Clutch Shaft	1
3	K0278	Double Indented Washer 7/16" / 1.375 OD x .440 ID x .179 T	1
4	K0140	Lock Washer 7/16" / High-Collar Helical Spring	1
5	K0359	HHCS / 7/16"-20 x 3.50" w/ Patch	1
6	M0309	A-Section Pulley / 4.75 OD (PTO-X)	1
7	S0221	Eng. Pulley Bushing #27	1
8	K0076	Key 1/4" x 3/4" Long	1



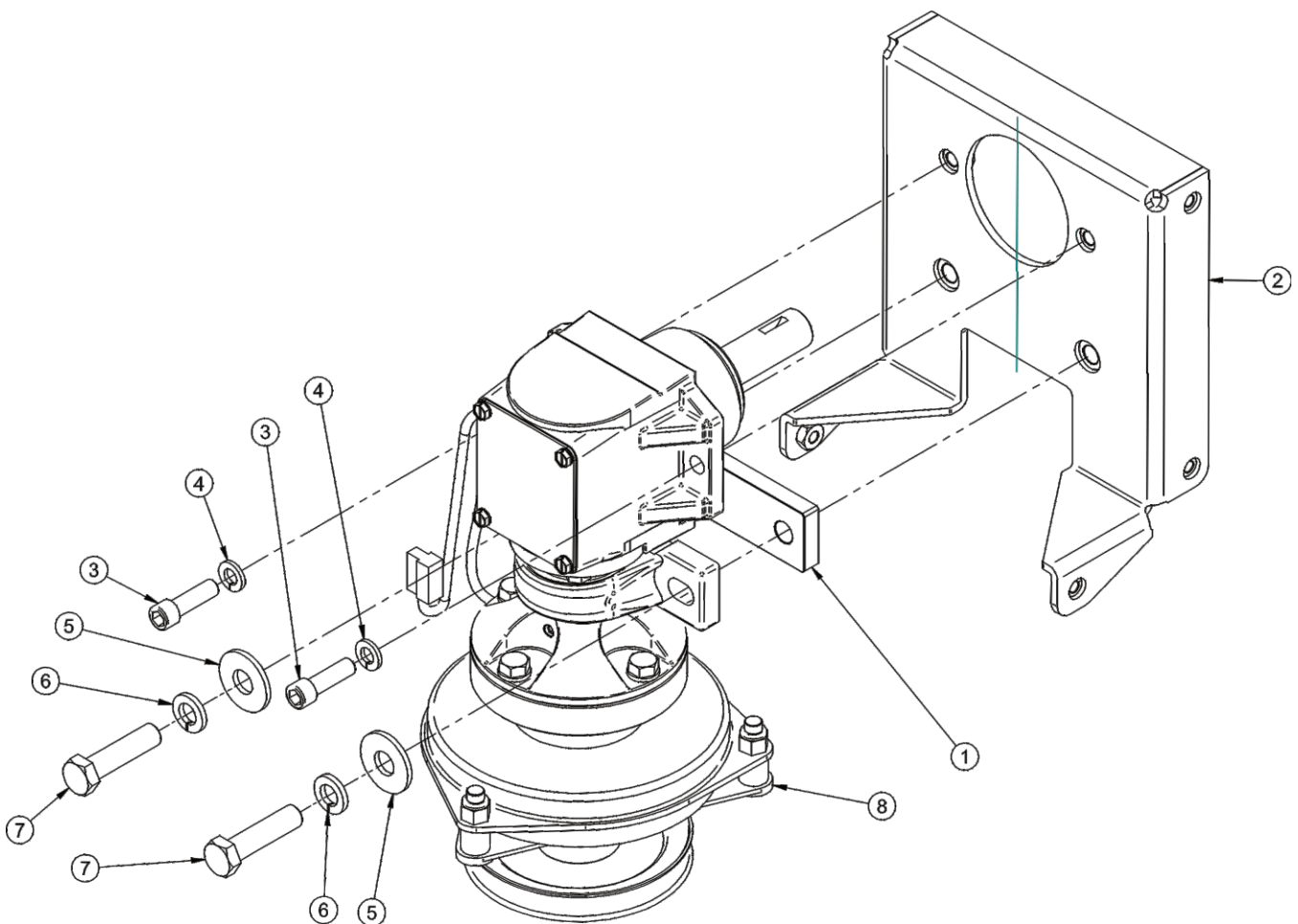
# A2057 01 Drive Assembly Exploded Parts View

Item #	Part #	Desc.	Qty.
1	K0048	Lock Washer 3/8"	4
2	K0343	HHCS 3/8"-16 x 7/8" GR8	4
3	A2059_01	Clutch Sub-Assy	1
4	A2058	Gearbox Sub-Assy	1



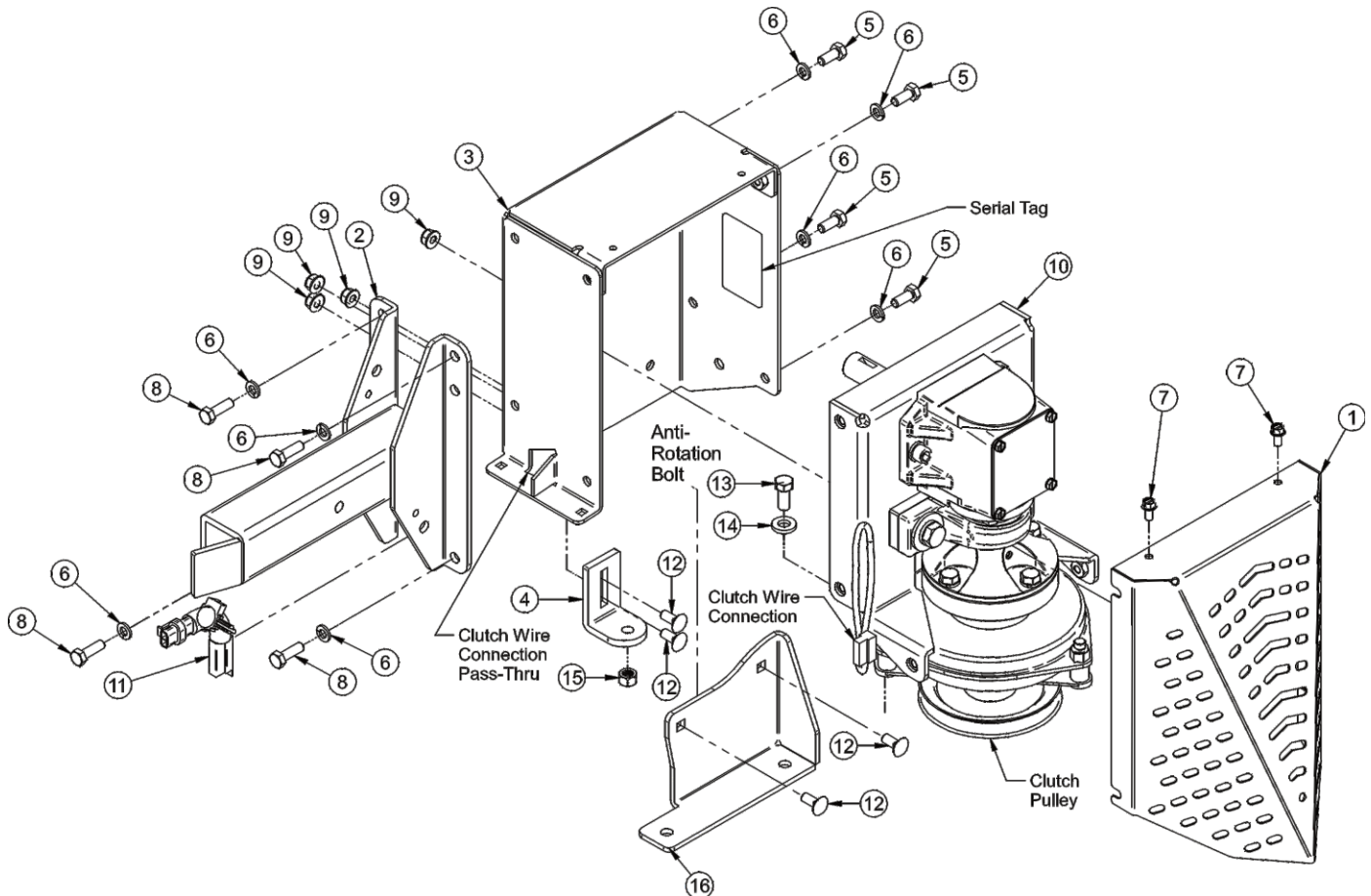
## A2060 01 Mounted Drive Assembly

Item #	Part #	Desc.	Qty.
1	B0940	Spacer Plate	1
2	A2034	Drive Mnt Assy	1
3	K0309	3/8"-16 x 1-1/4" SHCS	2
4	K0048	Lock Washer 3/8"	2
5	K0055	Flat Washer 1/2" / 1.383 OD x .560 ID x .120 T	2
6	K0056	Lock Washer 1/2"	2
7	K1234	HHCS 1/2"-13 x 2"	2
8	A2057_01	Drive Assy	1



# A2039 02 Base Drive Assembly

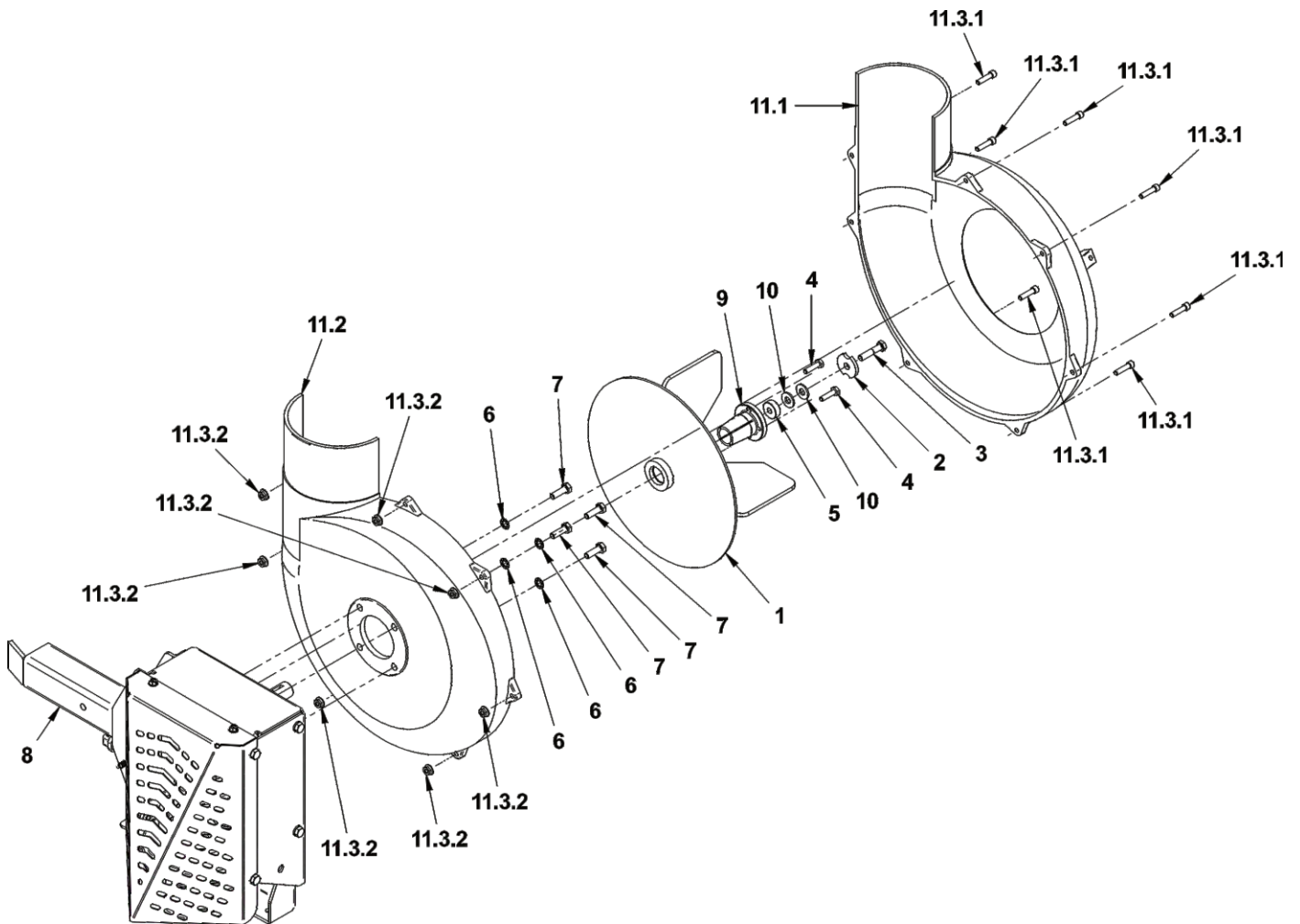
Item #	Part #	Desc.	Qty.
1	B0938_01	Drive Guard	1
2	A2032	Drive Arm Assy	1
3	A2035_02	Housing Mnt Assy	1
4	B0942_02	Anti-Rotation Brkt	1
5	K1153	HHCS 5/16"-18 x 3/4"	4
6	K0043	Lock Washer 5/16"	8
7	K0353	HWHTCS 1/4"-20 x 1/2"	2
8	K1154	HHCS 5/16"-18 x 1"	4
9	K2516	Ny-Flange Lock Nut 5/16"-18	4
10	A2060_01	Mounted Drive Assy	1
11	P0271	Quick Connect Wire Harness	1
12	K1142	5/16"-18 x 3/4" Carriage Bolt	4
13	K0343	HHCS 3/8"-16 x 7/8" GR8	1
14	K1477	Flat Washer / 3/8" / .406 ID x .812 OD x .125 Thk	1
15	K1476	Reverse Lock Nut / 3/8"-16 Grade C	1
16	B1100	Idler Assy Mount Plate	1





## A2061 02 Drive Assembly / 4 Blade Impeller

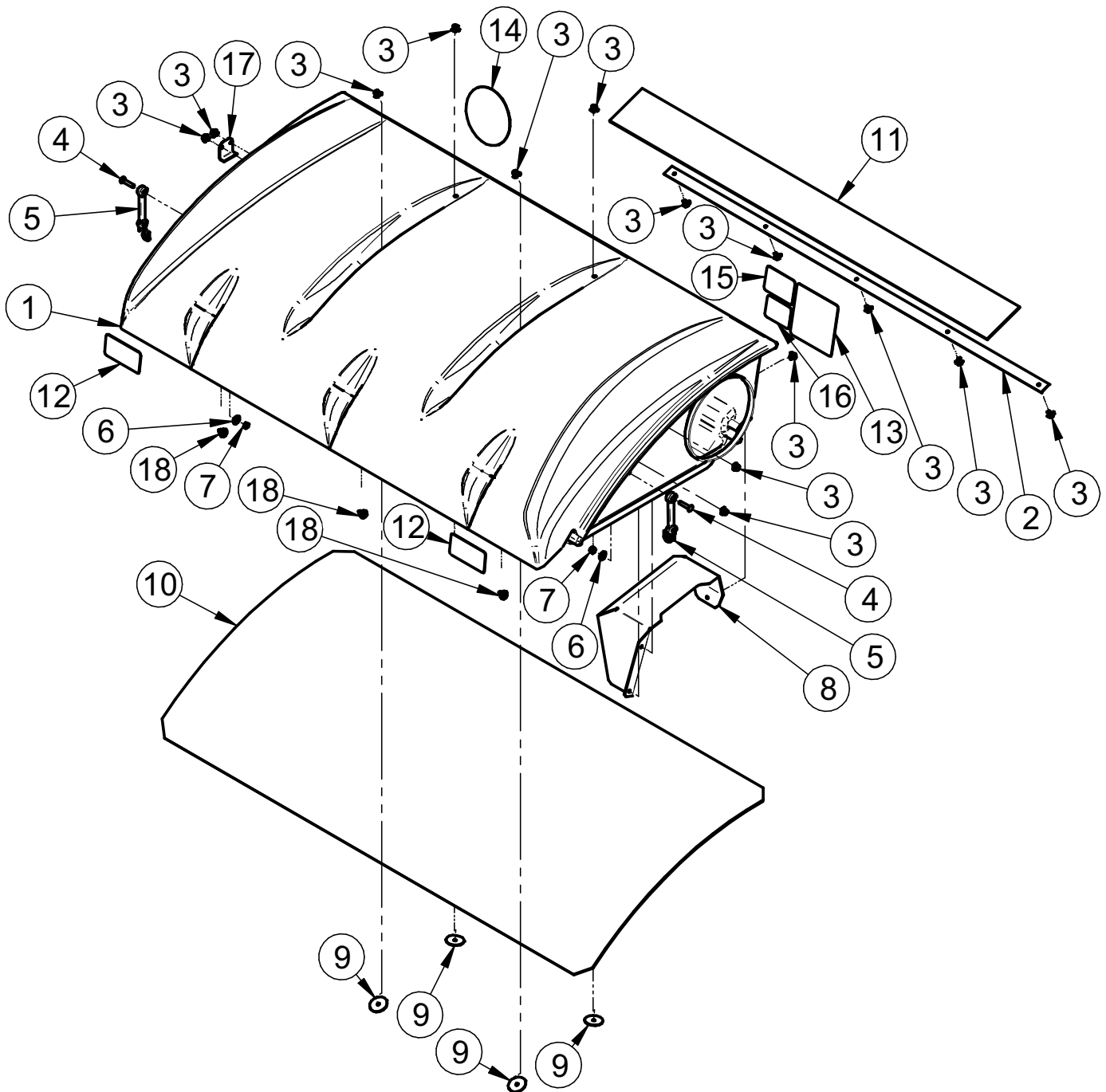
Item #	Part #	Desc.	Qty.
1	A0645	4-Blade Impeller Weldment	1
2	K0284	Double Indented Washer 3/8" / 1.375 OD x .380 ID x .179 T	1
3	K1465	HHCS 5/16"-24 x 1-1/2" GR8	1
4	K1225	HHCS 1/4"-20 X 1" GR8	2
5	S0159	Spacer Bushing .938 OD x .325 ID x .375 T	1
6	K0044	I/T Tooth Lock Washer 5/16"	4
7	K1154	HHCS 5/16"-18 x 1"	4
8	A2039_02	Drive Assy / Base	1
9	S0157	Taperlock Bushing 7/8"	1
10	K0042	Flat Washer 5/16" / .875 OD x .380 ID x .075 T	2
11	E4052A	Blower Hsg Assy	1
11.1	E4052F	Blower Hsg Front	1
11.2	E4052B	Blower Hsg Back	1
11.3	HB0462	HW Bag / E4004A & E4052A Housings	1
11.3.1	K1401	1/4"-20 x 1" SHCS / Zinc / GR8	7
11.3.2	K1126	Flange Nut 1/4"-20	7



# A1158 Top Assembly

## Exploded Parts View

Item #	Part #	Desc.	Qty.
1	V0022	Pro 3 Bagger Top	1
2	C0069	Dust Guard Brace	1
3	K0114	Black Plastic Rivet	14
4	K1030	1/4"-20 x 1-1/4" Carriage Bolt	2
5	J4009	Short Rubber Strap w/ S-Hook	2
6	K0037	Flat Washer / 1/4" (.75 OD x .312 ID x .060 T)	2
7	K1128	1/4"-20 Nyloc Nut	2
8	C0026	Grass Deflector	1
9	K0062	Fender Washer / .230 ID x 1.500 OD / Zinc	4
10	V1120	Black Plastic Screen	1
11	V1118	Dust Guard	1
12	R1057	Decal / 2" x 4" Red Reflector	2
13	R1069	Decal / Warning - Turn Off Blower	1
14	R0022	Decal / Built In The USA / Lg	1
15	R1054	Decal / Important Check Hoses	1
16	R1051	Decal / Warning - Use Hearing Protection	1
17	B0676	Hinge Stop Pl.	1
18	K1265	Black Panel Retainer	3



# Unit Model #: 47131506

Mower: Bush Hog

Owner's Manual: Q0526

Mower Type: HDC

Deck Size: 55" & 61"

Vac Type: P3B

Deck Type:

Drive Type: PTO-X

Revision #: 2 - Updated Mount Kit (May 2020)

Fits Year(s): 2018-Newer



<p><input type="checkbox"/> <b>A2170 Vac Kit</b></p> <p>(1) A1158 Top Assy</p> <p>(1) HB0717 Vac Kit Hardware Bag</p> <p>(1) F0080-34 8" x 34" Upper Hose</p> <p>(1) C0092 Exhaust Deflector</p> <p>(2) J0080 8" Hose Clamp</p> <p>(1) V0025 6" &amp; 7" Plastic Inlet</p> <p>(1) F0060-35 6" x 35" Lower Hose</p> <p>(2) J0060 6" Hose Clamp</p> <p>(1) A2068 Upper Frame Assembly</p> <p>(3) B0227 Bag Ring</p> <p>(2) B0640 Lwr. Mnt. Tubes (29")</p> <p>(3) G0013 Collection Bags</p>	<p><input type="checkbox"/> <b>A2169 Mount Kit</b></p> <p>(1) HB0702 Wiring Harness HW Bag</p> <p>(1) B1053 Left Frame Bracket</p> <p>(1) B1054 Rear Frame Bracket</p> <p>(1) B2070 Right Frame Bracket Spacer</p> <p>(1) B2071 Left Frame Bracket Spacer</p> <p>(1) E6009 8" Blower Cone</p> <p>(1) A2067_02 Idler Mount Assy</p> <p>(1) A2061_02 Drive Assy. w/ 4-Blade Impeller</p> <p>(1) HB0716 Mount Kit HW Bag</p> <p>(1) A2138 Mount Arm Assy</p> <p>(1) B2069_02 Belt Guard Assy</p> <p>(1) HB0720 Engine Pulley HW Bag</p> <p>(1) M0316 AK81 Belt</p>	<p><input type="checkbox"/> <b>A2165 Boot Kit</b></p> <p>(1) A2129 Boot Plate</p> <p>(1) HB0688 Boot Kit Hardware Bag</p> <p>(1) E0034A Boot w/ Decal</p> <p>(1) B0348 Boot Rod</p> <p><input type="checkbox"/> <b>A2121 Dual Weight Kit / Single Caster</b></p> <p>(1) Y0025 28 lb. Weight</p> <p>(2) B1015 Weight Bracket</p> <p>(1) HB0687 Hardware Bag</p> <p>(1) B1014 Dual Weight Bracket Base</p> <p><input type="checkbox"/> <b>A2121 Dual Weight Kit / Single Caster</b></p> <p>(1) Y0025 28 lb. Weight</p> <p>(2) B1015 Weight Bracket</p> <p>(1) HB0687 Hardware Bag</p> <p>(1) B1014 Dual Weight Bracket Base</p>
---	---	---

# SAFETY DECALS

To promote safe operation, New PECO, Inc. supplies safety decals on all products manufactured. Damage can occur to safety decals either through shipment, use or reconditioning. Contact your local Service Center for replacement decals.



Part# R1070  
PECO Logo



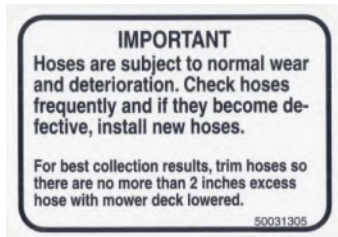
Part# R0022  
Designed & Built  
In The USA



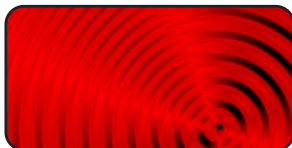
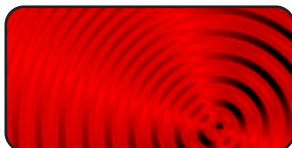
Part #: R2007  
Danger - Never Use Hands



Part #: R2008  
Danger - Rotating Blades



Part #: R1054  
Important - Hose Wear



Part #: R1057 - (2)  
Red Reflectors



Part #: R1069  
Warning - Turn Off Blower



Part # R0024  
Danger - Keep Hands  
Clear



Part #: R1051  
Warning - Hearing Protection



Part # R0025  
Danger - Rotating  
Blades

## SECTION III OPERATING INSTRUCTIONS

### General Safety

Only qualified people familiar with this operator's manual and the mower's operator's manual should operate this machine.

### Operation And Tips On Mowing

- A. Perform BEFORE EACH USE the maintenance list referenced in Section IV.
- B. Start mower.
- C. With the mower at high idle speed, engage the mower deck.
- D. While seated in the operator's seat, move Bagger PTO switch to the on position. With the PTO assembly engaged, you can proceed to operate the control levers of the mower.

**NOTE:** If the collection system does not appear to be collecting the grass clippings, disengage the deck and PTO assembly, then, engage the parking brake and turn the mower off. Check upper and lower hoses for any clogs.

To obtain the maximum effectiveness from your collection system, the tips listed below should be followed:

- \* Watch your speed- Normal conditions will allow a speed of up to approximately 4 mph, but thick, heavy damp conditions will require reduced ground speed.
- \* Mow with sharp blades- A sharp blade cuts cleaner.
- \* Wet grass and leaves will decrease effectiveness and will increase horsepower requirements.
- \* Mow at higher cutting heights- Remove and mulch no more than 2" of grass length with each mowing. (Experts recommend not cutting off more than 1/3 of the grass blade length at any given time.)
- \* Mow twice, at different height settings, (high, then low), if grass is extra tall.
- \* Remember that horsepower requirements will vary with the mowing conditions such as type and height of turf grass, moisture content, amount of leaves, whether the terrain is flat or hilly, etc.

### Disengagement Of The PTO Assembly

- A. To disengage the PTO assembly, move Bagger PTO switch to the off position.

**WARNING:** The PTO assembly blades will continue to spin. DO NOT TOUCH the PTO assembly, pulleys, or the belt until the tractor is turned off. DO NOT adjust the belt tension until the mower is turned off. Refer to the Belt Installation section of the manual.

### Unloading The Collection System

**NOTE:** To determine when the collection bags are full, follow the following steps:

- A. Stop the forward movement of the mower.
- B. Disengage the mower deck.
- C. Disengage the PTO assembly.
- D. Engage the parking brake.
- E. Once the parking brake has been engaged, then and only then, walk behind the mower and check the collection bags by first unhooking the rubber strap with S-hook that secures the plastic top, then lift the plastic hood. Load in bags should not exceed the height of the installed bag.
- F. To remove the bags from the frame, slide bags out and turn bags over to deposit clippings.
- G. Slide empty bags back onto the frame and secure plastic top with the rubber strap with S-hook.

**NOTE:** Do not allow collection bags to become over-filled as potential damage may occur to your equipment. Also, be sure to clean the hood screen as needed.

## SECTION IV MAINTENANCE

### Maintenance Checklist

Before each use:

1. Check blades and spindles to be sure that no foreign objects, such as wire or steel strapping bands, are wrapped around them.
2. Inspect blades for wear. Replace if necessary. If it is necessary to sharpen the blades, remove the blades from the spindles before sharpening. DO NOT sharpen blades while still attached to the mower.

3. Make sure all shields are in place and in good condition. Repair or replace any missing or damaged shields.
4. Perform lubrication per instructions.
5. Listen for abnormal sounds, which might indicate loose parts, damaged bearings, or other damage. Correct any deficiency before continuing operation.
6. With the engine off, engage the blower assembly. Check the belt tension and inspect the pulley belt for cracks or tears.
7. Check for wear or deterioration of the upper or lower hoses. If there are any portions of the hose that have been torn or worn through, replace immediately.

After Each Use:

1. Clean all debris from machine especially from the container, underneath the belt shields, and safety decals. Replace any missing or illegible decals.
2. Inspect the unit for worn or damaged components. Repair or replace before the next use. Any replacement component installed during repair shall include the component's current safety decal specified by the manufacturers to be affixed to the component.
3. Under normal usage, the bag material is subject to deterioration and wear and should therefore be frequently checked for necessary replacement. Any replacement bag should be checked to ensure compliance with the original manufacturer's recommendations or specifications.
4. Check belt for proper tension.

## Lubrication

Gearbox:

**NOTE:** The gearbox is filled with 6.0 oz. of Mobilube HD Plus 80W-90 oil and permanently sealed. There is no need for scheduled lubrication. The oil level should only be checked if a leak is observed or if a change in gearbox noise is noticed.

Operators are recommended to check for leaks weekly. If a leak is observed, both the gasket and the seals are recommended to be replaced.

Replace the oil using 5.5 oz. of the recommended Mobilube HD Plus 80W-90 oil. Be sure to not overfill.

Blower Assembly:

**NOTE:** The following is for older PTO models that contain a greaseable zirc fitting. Newer models contain maintenance-free bearings and are without a greasable fitting.

1. On initial use: Grease the fitting on the blower shaft.
2. Every 25 hours of use: Re-grease the grease fitting.

**NOTE:** Use only white lithium based grease for lubrication of the shaft on the blower assembly.

## SECTION V - PARTS & SERVICE

### Parts And Service Information

Collection system owners should record the name and telephone number of their Service Center. Your Service Center will be happy to supply replacement parts, accessories, and do any service or repairs to your collection system. If for any reason your Service Center is unable to service your collection system or supply replacement parts, contact New PECO, Inc. and include the following information on the chart below.

### DOCUMENT THE FOLLOWING INFORMATION FOR FUTURE REFERENCE

**Unit Model Number:** \_\_\_\_\_

**Unit Engine Size:** \_\_\_\_\_

**Unit Serial Number:** \_\_\_\_\_

**Date of purchase:** \_\_\_\_ / \_\_\_\_ / \_\_\_\_

**Dealer/Distributor Name:** \_\_\_\_\_

**Address:** \_\_\_\_\_ **State:** \_\_\_\_\_ **Zip:** \_\_\_\_\_

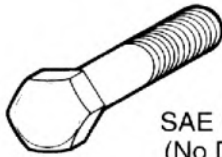
**Phone Number:** \_\_\_\_\_

**New PECO, Inc.**  
**10 Walden Dr | Arden, North Carolina 28704**  
**Phone: 1-800-438-5823 | 828-684-1234**  
**Fax: 828-684-0858**  
**Email: [peco@lawnvac.com](mailto:peco@lawnvac.com)**  
**Website: [www.lawnvac.com](http://www.lawnvac.com)**

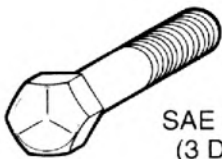
# TORQUE SPECIFICATIONS

Proper torque for American fasteners used on Peco equipment.  
Recommended Torque in Foot Pounds (Newton Meters).\*

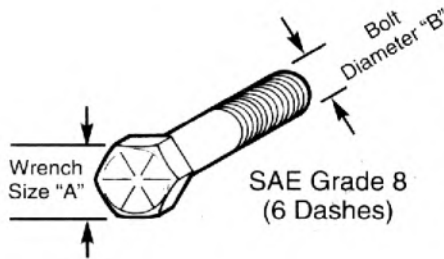
## AMERICAN Bolt Head Markings



SAE Grade 2  
(No Dashes)



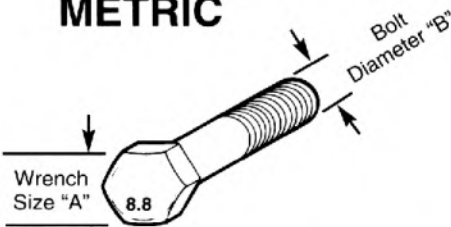
SAE Grade 5  
(3 Dashes)



SAE Grade 8  
(6 Dashes)

WRENCH SIZE (IN.) "A"	BOLT DIAMETER (IN.) "B" AND THREAD SIZE	SAE GRADE 2	SAE GRADE 5	SAE GRADE 8
7/16	1/4 - 20 UNC	6 (7)	8 (11)	12 (16)
7/16	1/4 - 28 UNF	6 (8)	10 (13)	14 (18)
1/2	5/16 - 18 UNC	11 (15)	17 (23)	25 (33)
1/2	5/16 - 24 UNF	13 (17)	19 (26)	27 (37)
9/16	3/8 - 16 UNC	20 (27)	31 (42)	44 (60)
9/16	3/8 - 24 UNF	23 (31)	35 (47)	49 (66)
5/8	7/16 - 14 UNC	32 (43)	49 (66)	70 (95)
5/8	7/16 - 20 UNF	36 (49)	55 (75)	78 (106)
3/4	1/2 - 13 UNC	49 (66)	76 (103)	106 (144)
3/4	1/2 - 20 UNF	55 (75)	85 (115)	120 (163)
7/8	9/16 - 12 UNC	70 (95)	109 (148)	153 (207)
7/8	9/16 - 18 UNF	79 (107)	122 (165)	172 (233)
15/16	5/8 - 11 UNC	97 (131)	150 (203)	212 (287)
15/16	5/8 - 18 UNF	110 (149)	170 (230)	240 (325)
1-1/8	3/4 - 10 UNC	144 (195)	266 (360)	376 (509)
1-1/8	3/4 - 16 UNF	192 (260)	297 (402)	420 (569)
1-5/16	7/8 - 9 UNC	166 (225)	430 (583)	606 (821)
1-5/16	7/8 - 14 UNF	184 (249)	474 (642)	668 (905)
1-1/2	1 - 8 UNC	250 (339)	644 (873)	909 (1232)
1-1/2	1 - 12 UNF	274 (371)	705 (955)	995 (1348)
1-1/2	1 - 14 UNF	280 (379)	721 (977)	1019 (1381)
1-11/16	1-1/8 - 7 UNC	354 (480)	795 (1077)	1288(1745)
1-11/16	1-1/8 - 12 UNF	397 (538)	890 (1206)	1444 (1957)
1-7/8	1-1/4 - 7 UNC	500 (678)	1120 (1518)	1817 (2462)
1-7/8	1-1/4 - 12 UNF	553 (749)	1241 (1682)	2013 (2728)
2-1/16	1-3/8 - 6 UNC	655 (887)	1470 (1992)	2382 (3228)
2-1/16	1-3/8 - 12 UNF	746 (1011)	1672 (2266)	2712 (3675)
2-1/4	1-1/2 - 6 UNC	870 (1179)	1950 (2642)	3161 (4283)
2-1/4	1-1/2 - 12 UNF	979 (1327)	2194 (2973)	3557 (4820)

## METRIC



Numbers appearing on bolt heads indicate ASTM class.

Proper torque for metric fasteners used on Peco equipment.  
Recommended torque in foot pounds (newton Meters).\*

WRENCH SIZE (mm) "A"	BOLT DIA. (mm) "B"	ASTM 4.6	ASTM 8.8	ASTM 9.8	ASTM 10.9
8	5	1.8 (2.4)		5.1 (6.9)	6.5 (8.8)
10	6	3 (4)		8.7 (12)	11.1 (15)
13	8	7.3 (10)		21.1 (29)	27 (37)
16	10	14.5 (20)		42 (57)	53 (72)
18	12	25 (34)	74 (100)	73 (99)	93 (126)
21	14	40 (54)	118 (160)	116 (157)	148 (201)
24	16	62 (84)	167 (226)	181 (245)	230 (312)
30	20	122 (165)	325 (440)		449 (608)
33	22		443 (600)		611 (828)
36	24	211 (286)	563 (763)		778 (1054)
41	27		821 (1112)		1138 (1542)
46	30	418 (566)	1119 (1516)		1547 (2096)

\*Use 75% of the specified torque value for plated fasteners. Use 85% of the specified torque values for lubricated fasteners.

# Troubleshooting

2017 (v1.0)

## Collection System Performance

<b>Problem</b>	<b>Possible Cause</b>	<b>Corrective Action</b>
Abnormal Vibration	<ul style="list-style-type: none"> <li>• Cutting blades are bent or unbalanced</li> <li>• Loose blower pulley or pulley assembly</li> <li>• Impeller blade out of balance</li> </ul>	<ul style="list-style-type: none"> <li>• Install new cutting blade</li> <li>• Tighten the pulley</li> <li>• Contact dealer to replace</li> </ul>
Reduced collection system performance	<ul style="list-style-type: none"> <li>• Low engine speed</li> <li>• Plugged screen</li> <li>• Loose belt</li> <li>• Full collection bags</li> </ul>	<ul style="list-style-type: none"> <li>• Always operate collection system at full throttle</li> <li>• Remove debris, leaves, or grass clippings from the screen</li> <li>• Replace/tighten belt</li> <li>• Empty the collection bags</li> </ul>
Blower and hoses plugging too frequently	<ul style="list-style-type: none"> <li>• Collection bags are too full</li> <li>• Low engine speed</li> <li>• Grass is too wet</li> <li>• Grass is too long</li> <li>• Ground speed is too fast</li> <li>• Worn belt</li> <li>• Loose belt</li> </ul>	<ul style="list-style-type: none"> <li>• Dump more frequently</li> <li>• Always operate collection system at full throttle</li> <li>• Cut grass when it is dry</li> <li>• Cut the grass several times</li> <li>• Drive slower at full throttle</li> <li>• Replace belt</li> <li>• Adjust the pulley and tighten belts</li> </ul>
Debris blowout	<ul style="list-style-type: none"> <li>• Collection bags are too full</li> <li>• Plug/clog in the collection system</li> <li>• Ground speed is too fast</li> </ul>	<ul style="list-style-type: none"> <li>• Dump more frequently</li> <li>• Clean the collection system</li> <li>• Drive more slowly at full throttle</li> </ul>
Impeller doesn't rotate freely	<ul style="list-style-type: none"> <li>• Plug in the blower housing</li> <li>• Worn impeller blade</li> <li>• Shaft bearings bad/failing</li> </ul>	<ul style="list-style-type: none"> <li>• Clean the blower housing</li> <li>• Contact dealer to replace</li> <li>• Contact dealer to replace</li> </ul>



Notes



**New PECO, Inc.**  
**10 Walden Dr | Arden, North Carolina 28704**  
**Phone: 1-800-438-5823 | 828-684-1234**  
**Fax: 828-684-0858**  
**Email: [peco@lawnvac.com](mailto:peco@lawnvac.com)**  
**Website: [www.lawnvac.com](http://www.lawnvac.com)**