



PTO-X DRIVEN - GRASS COLLECTION SYSTEM

Model# 28120902

MODEL YEAR:
2016-NEWER

Z400 Kommander Pro
48" DECK

Kubota®



OPERATOR'S MANUAL

ASSEMBLY • OPERATION • MAINTENANCE

GRASS COLLECTION SYSTEM

TABLE OF CONTENTS

SECTION	PAGE	SECTION	PAGE
Safety	2	Length of Hose Adjustment	18
Safety Alert Symbols	3	Upper Hose Installation	18
Warranty	4	Lower Hose To Blower Cone Installation	18
I INTRODUCTION AND DESCRIPTION	5	Lower Hose To Boot Installation	18
Introduction	5	Safety Interlock Wiring Harness Installation	19-21
Description	5	Impeller Blade Removal/Replacement	22
II INSTALLATION FOR USE	6	Weight Kit Installation	23
Preparation Of Mower	6-7	Exploded Views & Parts List	24-32
Rear Mount Plate & Mount Arm Assy Installation	8	Overall Parts List	33
PTO Drive Assy	9-10	Safety Decals	34
Drive Assembly and Belt Installation	11	III OPERATING INSTRUCTIONS	35
Blower Cone Installation	12	General Safety	35
Boot Kit Installation	13	Operation & Tips On Mowing	35
Lower Mount Tube Installation	14	Disengagement Of The PTO Assembly	35
Upper Frame Assy Installation	14	Unloading The Collection System	35
Top Assy To Upper Frame Assy Installation	15	IV MAINTENANCE	35-36
Inlet Installation	15	Maintenance Checklist	36
Hinge Kit Assy Installation	16	Lubrication	36
Even Bag Fill Adjustment	16	V PARTS AND SERVICE	36
Bag Assy	17	Parts And Service Information	36
Bag Assy Installation	17	Torque Specifications	37
		Troubleshooting	38

SAFETY

1. Read the operator's manual carefully and familiarize yourself with the proper use of your attachment. Do not allow anyone who is not acquainted with the Safety Instructions to use your attachment.
2. Know the controls and how to stop them quickly. **READ THE OPERATOR'S MANUAL!**
3. Do not allow children to operate the machine. Do not allow adults to operate it without proper instruction.
4. Be especially watchful of children and pets entering into the area while operating.
5. Keep your eyes and mind on your machine while mowing or operating your attachment. Don't let others distract you.
6. Do not attempt to operate your machine when not in the driver's seat.
7. Always shut off blades and engine when emptying the container.
8. Stop machine, shut off deck attachment, set parking brake, shut off engine and remove ignition key before removing clogs, removing or replacing hose, boot, blower cone, or performing any maintenance.
9. Mow across the face of slopes (not more than 10 degrees); never up and down the face.
10. It is recommended that the container be emptied when half full while operating on slopes. Start mowing on slopes when the container is empty.
11. Inspect your lawn and remove any foreign objects before mowing. Never deliberately run the mower across any foreign object.
12. Wear hearing protection.
13. Wear eye protection to prevent debris from getting into your eyes.

SAFETY

WARNING! NEVER operate the mower unless the discharge guard and either the deflector assembly or the vacuum collector adapter are fastened securely in place.

WARNING! Do not work around the mower deck boot or the blower area until you are certain that the mower blades and the blower impeller have stopped rotating.

WARNING! To avoid serious injury, perform maintenance on the vacuum collector; **ONLY AFTER STOPPING THE MOWER'S ENGINE AND WAITING FOR ALL MOVING PARTS TO COME TO A COMPLETE STOP.** Set the parking brake. Always remove the ignition key before beginning maintenance.

WARNING! For your own personal safety, **ALWAYS mow ACROSS the face of slopes and NEVER UP and DOWN the face. NEVER attempt to mow excessively steep slopes, and use caution when turning on any slope.**

Safety Alert Symbol



This Safety Alert Symbol means: **“ATTENTION! BECOME ALERT! YOUR SAFETY IS INVOLVED!”**

This symbol is used to call attention to safety precautions that should be followed by the operator to avoid accidents. When you see this symbol, carefully read the message that follows and heed its advice. Failure to comply with safety precautions could result in death or serious bodily injury.

Safety Signs

The signal words **DANGER**, **WARNING**, and **CAUTION** are used on the equipment safety signs. These words are intended to alert the viewer to the existence and the degree of hazard seriousness.



White letters on **RED**

This signal word indicates a potentially hazardous situation which, if not avoided, will result in death or serious injury.



Black letters on **ORANGE**

This signal word indicates a potentially hazardous situation which, if not avoided, could result in death or serious injury.

It may also be used to alert against unsafe practices.



Black letters on **YELLOW**

This signal word indicates a potentially hazardous situation which, if not avoided, will result in minor or moderate injury.

It may also be used to alert against unsafe practices.

PECO LIMITED WARRANTY FOR NEW PRODUCTS

New PECO, Inc. extends the following warranties to the ORIGINAL PURCHASER of each New PECO, Inc. consumer product purchased from one of our Dealers or directly from New PECO, Inc., subject to the following limitations:

A. ITEMS COVERED UNDER WARRANTY

1. **PRODUCT WARRANTY** – Any part or parts which are deemed defective in material or workmanship, as delivered to the original purchaser, will either be repaired or replaced, as New PECO, Inc. elects, without charge for parts or labor, if the defect appears within 12 months from the date of purchase of the product to the Original Purchaser.
2. **PARTS REPLACED DURING WARRANTY** – Any New PECO, Inc. part which is furnished in performance of this warranty and is defective in material or workmanship as delivered to the purchaser will be repaired or replaced, as New PECO, Inc. elects, before the expiration of the original warranty period.

B. WARRANTY DISTINCTIONS

1. **RESIDENTIAL** - Products put to a personal use around a single household or residence are considered Residential. Products designated as “Residential” are warranted for 12 months from the date of purchase of the product, to the ORIGINAL PURCHASER with proof of purchase, when used for or in residential applications.
2. **COMMERCIAL** – Products put to any business use (agricultural, commercial or industrial) or used at multiple locations are considered Commercial. Products designated as “Commercial” are warranted for 12 months from the date of purchase of the product, to the ORIGINAL PURCHASER with proof of purchase, when used for or in commercial applications. Products designated as “Residential” are warranted for 90 days from the date of purchase of the product, to the ORIGINAL PURCHASER with proof of purchase, when used for or in Commercial applications.
3. **RENTAL** – Products used for Rental or Lease Purposes are warranted for 45 days from date of purchase of the product, to the ORIGINAL PURCHASER with proof of purchase, when used for or in a rental business.

C. ITEMS NOT COVERED BY NEW PECO WARRANTY

1. **ENGINES & BATTERIES:** Engines and Batteries attached to New PECO, Inc. products are covered under their respective separate manufacturer warranties and those companies must be contacted directly to file a warranty claim. Briggs & Stratton: https://www.briggsandstratton.com/na/en_us/support/warranty.html
2. **UNAPPROVED ALTERATION OR MODIFICATION:** All obligations of New PECO, Inc. under this warranty shall be terminated if products are altered or modified in any way not approved by New PECO, Inc.
3. **ACCIDENTS & NORMAL MAINTENANCE:** This warranty covers ONLY manufacturers defective material and workmanship. It does not cover depreciation or damage caused by normal wear & tear, accident, improper maintenance, misuse or abuse of products. New PECO, Inc. products must be operated and maintained in accordance with the instructions furnished in the manuals. The cost of normal maintenance and normal replacement of service items such as belts, cutting blades, hoses, bags, etc., which are not defective shall be paid for by the purchaser.
4. **NO SERVICE CENTER WARRANTY:** The selling Service Center/Dealer makes no warranty on his own on any item warranted by New PECO, Inc. unless he delivers to purchaser a separate written warranty certificate specifically warranting the item. The Service Center or Dealer has no authority to make any representation or promise on behalf of New PECO, Inc. or to modify the terms of the original warranty in any way.
5. **NO REPRESENTATIONS ADDITIONAL WARRANTIES, DISCLAIMER:** Neither New PECO, Inc. nor any company affiliated with New PECO, Inc. makes any warranties, representations or promises as to the quality of performance of its products other than those set forth herein. Except as described above, New PECO, Inc. makes no other warranties **AND SPECIFICALLY DISCLAIMS ANY AND ALL IMPLIED WARRANTIES OF FITNESS AND MERCHANTABILITY.**
6. **REMEDIED EXCLUSIVE:** The only remedies the purchaser has in connection with the breach or performance of any warranty on New PECO, Inc. consumer products are set forth above. In no event will New PECO, Inc. be liable for special incidental or consequential damages.

Warranty service is available through your local authorized service dealer or distributor. If you do not know the dealer or distributor in your area, search by your zip code on www.lawnvac.com or contact our Sales Department at New PECO, Inc. 800-438-5823 or email Sales@lawnvac.com.

Section I - INTRODUCTION AND DESCRIPTION

Introduction

We are pleased to have you as a PECO customer. Your collection system has been designed to give you a low maintenance, simple, and effective way to collect the grass clippings from your mower. The manuals are provided to give you the necessary instructions to properly mount, operate and maintain the collection system on your mower. Please read this manual thoroughly. Understand what each control is for and how to use it. Observe all safety decal precautions on the machine and noted throughout the manual.

NOTE: All references made to right, left, front, rear, top or bottom are as viewed from the normal operator's position on the mower.

Description

The grass collection system is designed for turf maintenance where there is a need to collect the grass clippings as the mower cuts the turf. It is also used for picking up leaves in pre-season and post-season clean-up. The blower, mounted on the right side of the unit, uses a belt and gearbox system from the engine PTO shaft. Drive train protection comes through belt slippage. The blower draws grass clippings from the discharge area of the cutting deck back to the collection bags at the rear portion of the mower frame. The operator can engage the blower with a toggle switch mounted on the control panel to the right of the operator. Once the bags are full with clippings, they can be easily released for dumping.



Section II - INSTALLATION FOR USE

Preparation Of Mower

NOTE: The mower deck PTO belt must be removed from the electric clutch before continuing with the installation. Refer to your mower's owner's manual for instructions on PTO belt removal.

From the underside of the engine, disconnect the wiring harness attached to the electric clutch. Remove the bolt, washer and electric clutch from the mower. Refer to Figure A & B.

Figure A

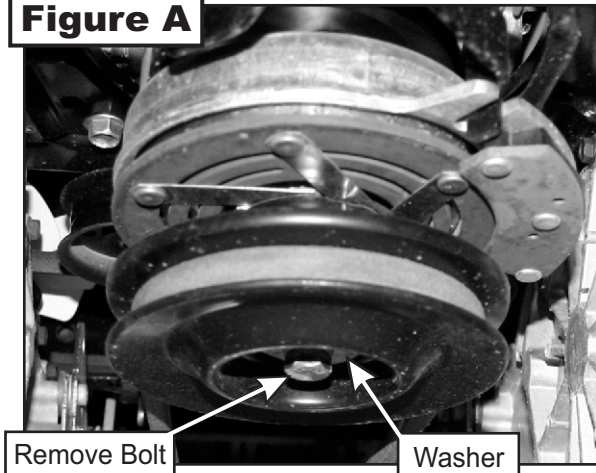
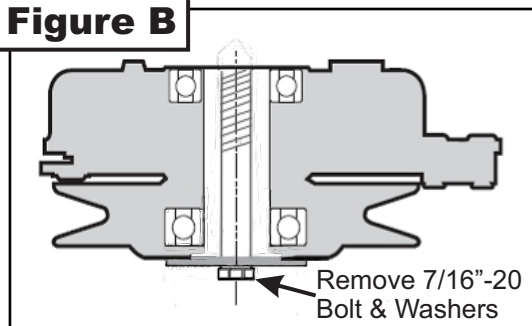
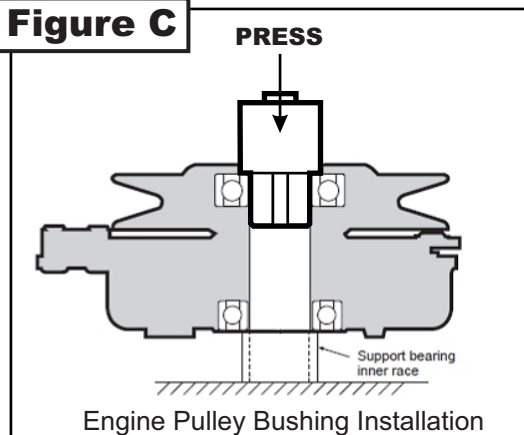

Figure B



Once the clutch is removed, install the Engine Pulley Bushing to the underside of the clutch as shown in Figure C. The Engine Pulley Bushing must be installed using an arbor press or equivalent. During installation, opposite bearing inner race must be supported or bearing damage may occur.

Figure C



Once the Engine Pulley Bushing is attached, align the Engine Pulley center cutout to the bottom of the Engine Pulley Bushing. Fasten the Engine Pulley Assembly using (1) Clamp Washer, (1) Lock Washer, and (1) Hex Bolt. Torque the bolt to 55 ft./lbs. The added Engine Pulley Assembly will power the collection system and should resemble Figure E when installed.

Figure D

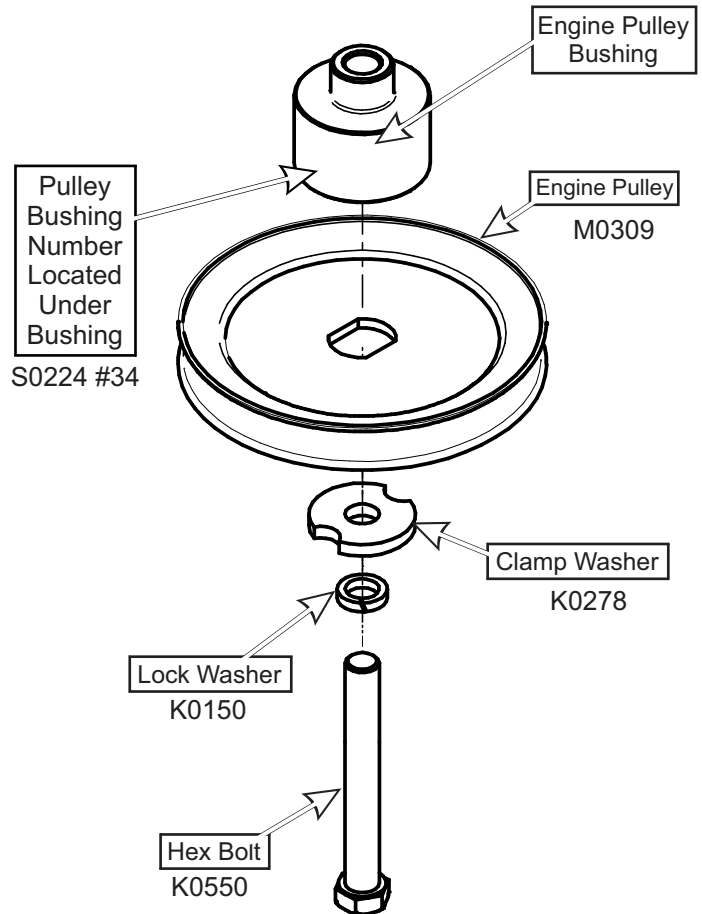
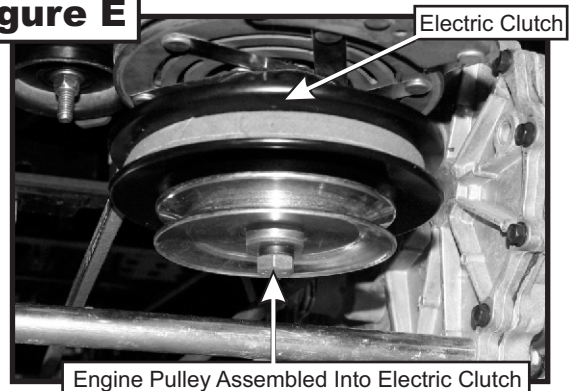

Figure E



Preparation of Mower (continued)

An Exhaust Diverter will need to be installed on your mower to prevent the exhaust from damaging the PTO Assembly.

Attach (1) Exhaust Diverter P#(J0293) to the engine exhaust pipe and secure the Exhaust Diverter using (1) Clamp Kit P#(X1064). Refer to Figure A.

Position the diverter so that the exhaust blows to the rear at about a 45 - 60 degree angle so that it does not burn the Collection Bags or the ground. Refer to Figure B.

Figure A

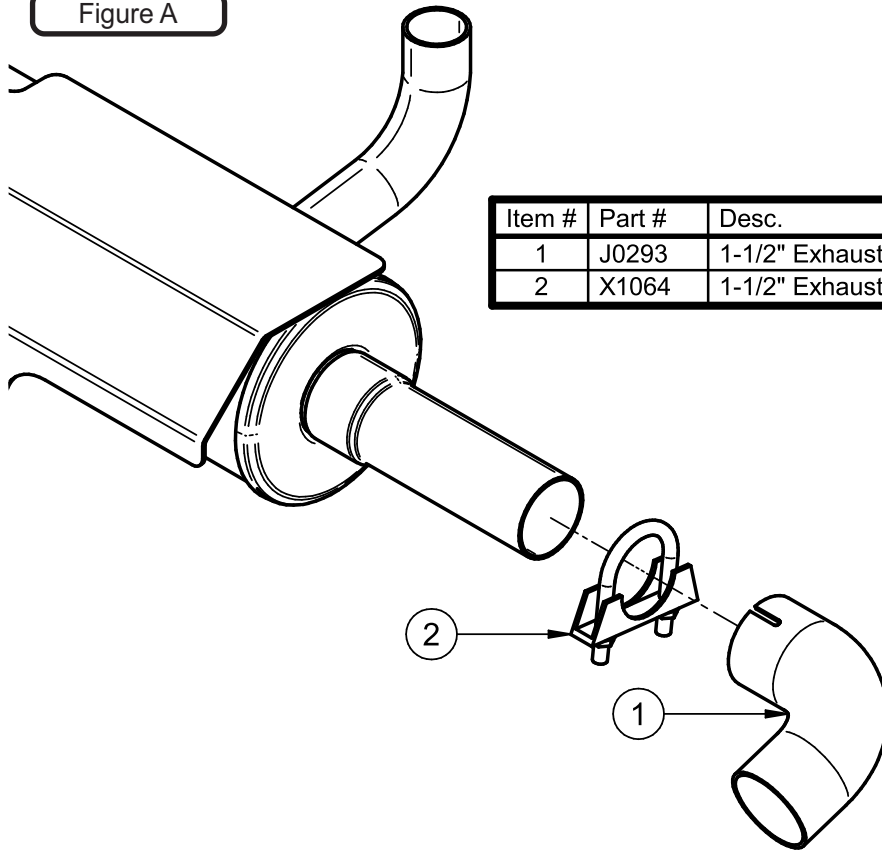

Item #	Part #	Desc.	Qty.
1	J0293	1-1/2" Exhaust Diverter	1
2	X1064	1-1/2" Exhaust Clamp Kit	1

Figure B

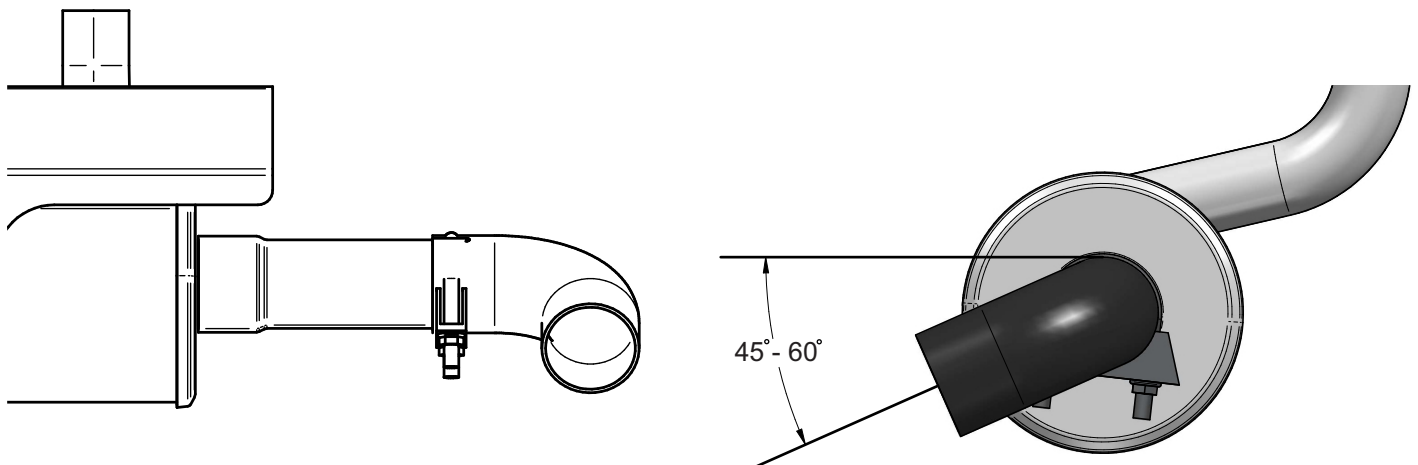

Rear Mount Plate & Mount Arm Assembly Installation

To install the Rear Mount Plate (Item #1), first remove (3) existing metric fasteners (Item #8) from the mower's upper bumper tube as shown below. Once removed, align Rear Mount Plate to the mower's upper bumper tube and loosely reattach the previously removed metric fasteners (Item #8). Next, fasten the lower portion of the Rear Mount Plate using (2) 3/8"-16 x 1" Carriage Bolts (Item #5) & (2) 3/8"-16 Ny-Flange Lock Nuts (Item #4) as shown below. Tighten all fasteners.

To install the Mount Arm Assembly (Item #2), first align holes to the right side of the Rear Mount Plate as shown and loosely fasten using (2) 3/8"-16 x 1" HHCS (Item #3) & (2) 3/8"-16 Ny-Flange Lock Nuts (Item #4). Next, loosely fasten the Mount Arm Assembly to the upper bumper tube using (1) 3/8"-16 U-Bolt (Item #6) & (2) 3/8"-16 Ny-Flange Lock Nuts (Item #4). Then, loosely fasten the Mount Arm Assembly to the lower bumper tube using (1) 3/8"-16 U-Bolt (Item #7) & (2) 3/8"-16 Ny-Flange Lock Nuts (Item #4). Tighten all fasteners.

Item #	Part #	Desc.	Qty.
1	B0992	Rear Mount Plate	1
2	A2127	Mount Arm Assy.	1
3	K1191	HHCS 3/8"-16 x 1" GR5	2
4	K2038	Ny-Flange Lock Nut 3/8"-16	8
5	K1182	Carriage Bolt 3/8"-16 x 1"	2
6	K1436	U-Bolt 3/8" x 2-1/4" x 1-3/4"	1
7	K1480	U-Bolt 3/8"-16 x 3-1/2" IW x 2-3/4" ID	1
8	Metric Bolt	Existing Bolt	4

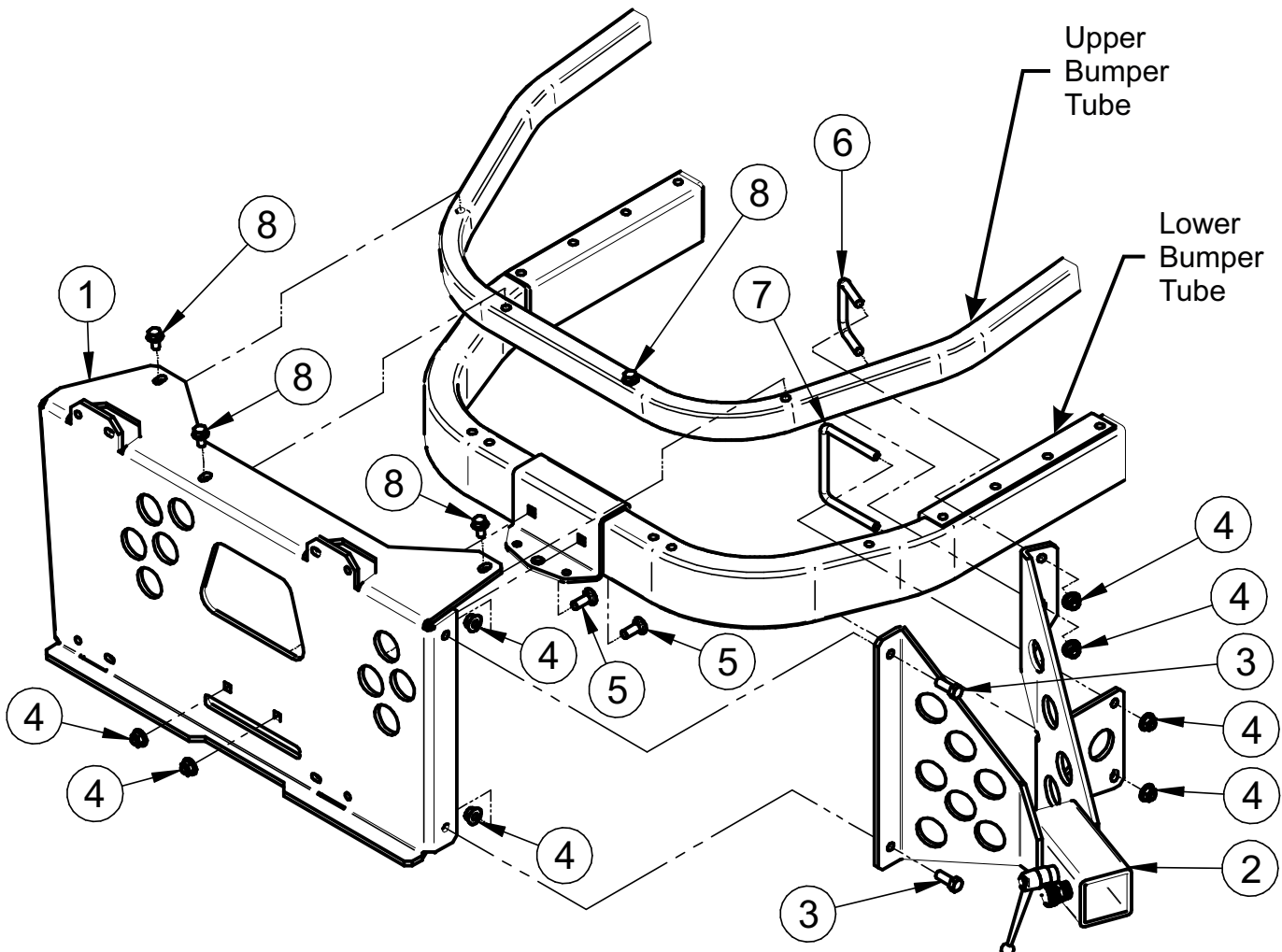

PTO Drive Assembly

Once the Mount Arm Assembly is installed and secured to the mower, assemble the Drive Assembly P#(A2061_01), Belt Guard Assembly P#(A2069_02) & Idler Mount Assembly P#(A2067_02).

First, attach the Belt Guard Assembly P#(A2069_02) to the Drive Assembly P#(A2061_01) using (2) 1/4"-20 x 5/8" Carriage Bolts P#(K1010) and (2) 1/4"-20 Ny-Flange Lock Nuts P#(K2014). Refer to Figure A. **Leave Bolts Loose.**

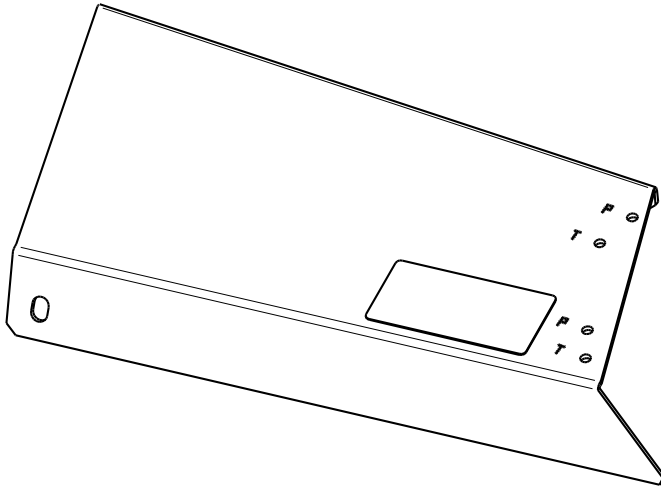

BELT GUARD ASSY. HOLES

Notice Marked Holes Below;
For This Installation, Use Holes
Marked With The Letter 'P'

Figure A

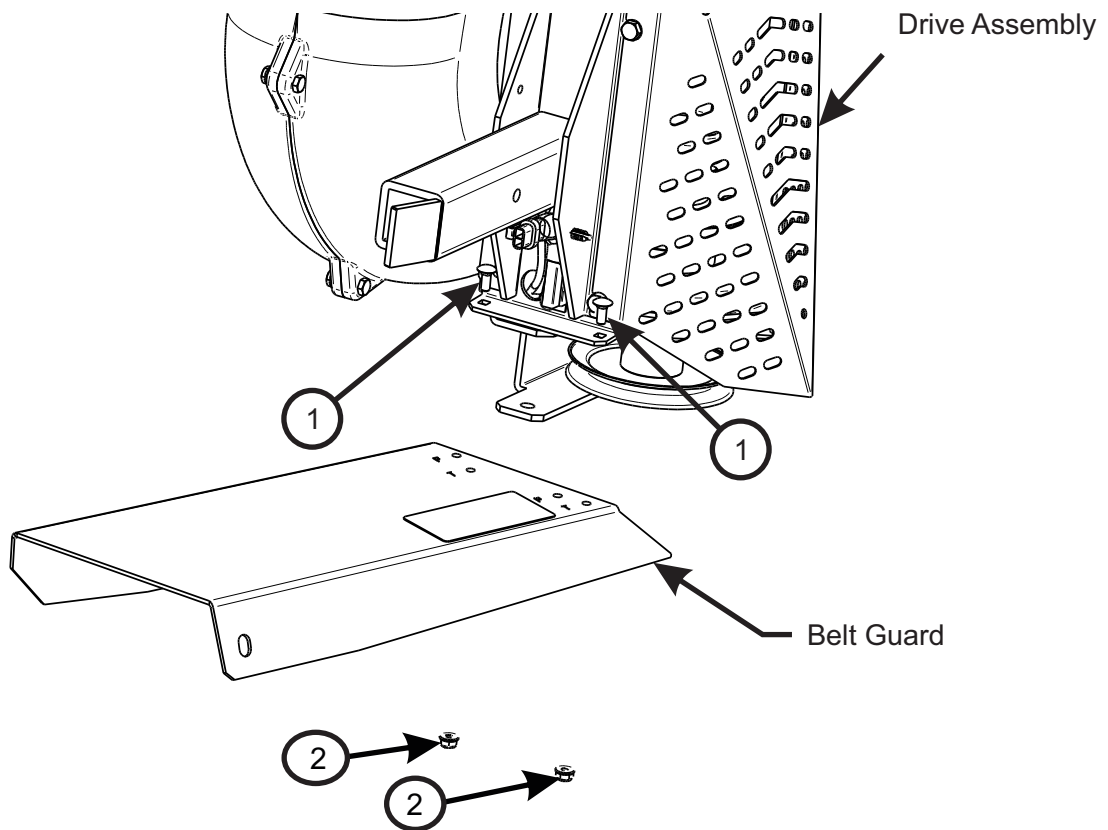

Item #	Part #	Desc.	Qty.
1	K1010	1/4"-20 x 5/8" Carriage Bolt	2
2	K2014	1/4"-20 Ny-Flange Lock Nut	2

PTO Drive Assembly (Continued)

Attach the Idler Mount Assembly P#(A2067_02) to the Drive Assembly using (1) 3/8"-16 x 1" HHCS (A) P#(K1191), (1) 3/8"-16 x 1" Carriage Bolt (B) P#(K1182) and (2) 3/8"-16 Ny-Flange Lock Nuts P#(K2038). Refer to Figure B. Leave Bolts Loose (Note: Orientation of bolts A & B.)

Next, secure the Idler Mount Assembly P#(A2067_02) to the Belt Guard Assembly P#(A2069_02) using (2) 3/8"-16 x 1" Carriage Bolts P#(K1182) and (2) 3/8"-16 Ny-Flange Lock Nuts P#(K2038). Refer to Figure C & D. Tighten All Bolts.

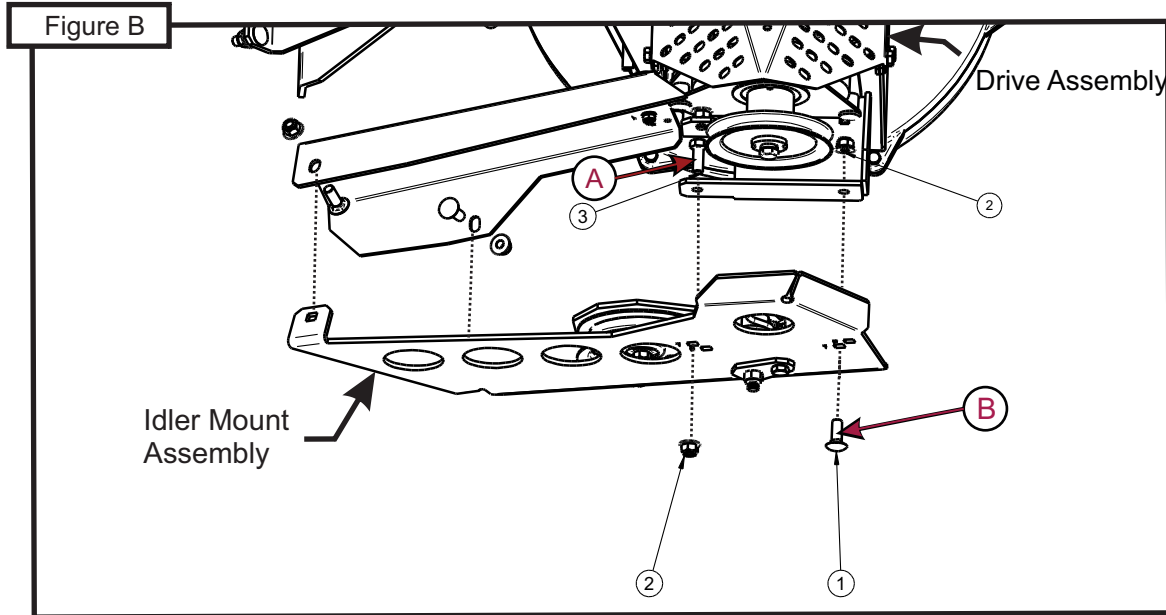

Item #	Part #	Desc.	Qty.
1	K1182	Carriage Bolt 3/8"-16 x 1"	1
2	K2038	Ny-Flange Lock Nut 3/8"-16	2
3	K1191	HHCS 3/8"-16 x 1" GR5	1

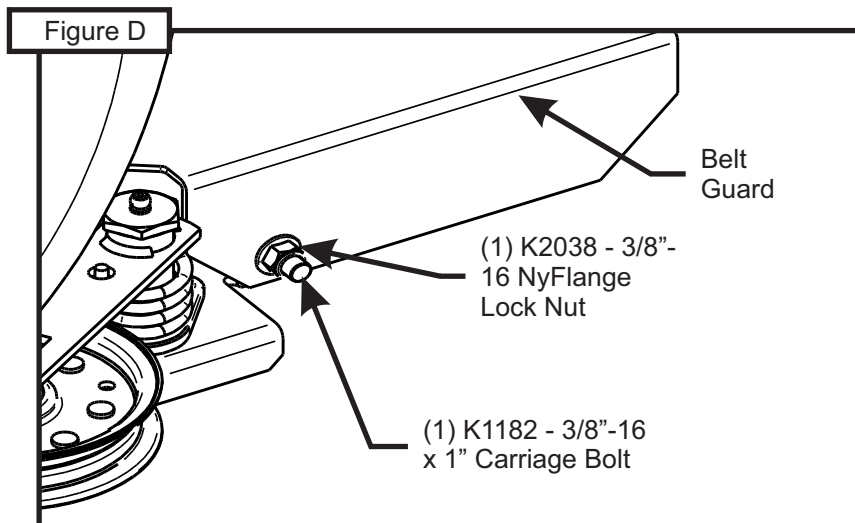
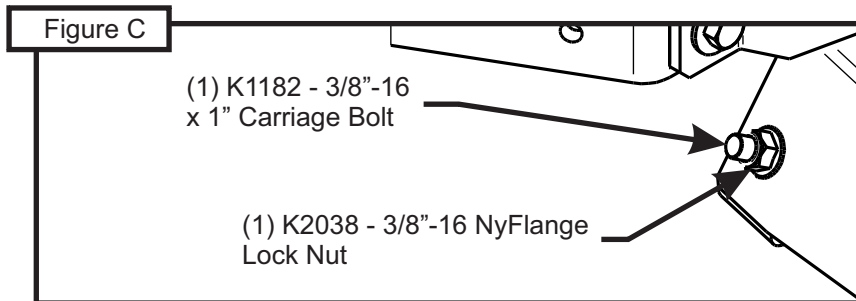

Drive Assembly and Belt Installation

(Note: It is recommended that someone assist during this step.)

Insert the Drive Assembly into the receiver tube on the Mount Arm Assembly until the Knob Plunger Pin engages. Once in place, turn Lock Handle clockwise until tight. Next, feed the AK79 Belt P#(M0313) between the Belt Guard and the Idler Mount Assembly. Place belt around the Engine Drive Pulley on the underside of the mower. While one person inserts a screw driver (or similar tool) into the Idler Mount Assembly and rotates lever arm clockwise, enough to relieve all tension from belt, place belt around the Drive Assembly Pulley. Once the belt is in position, carefully release the tension to tighten belt.

Refer to the images below.

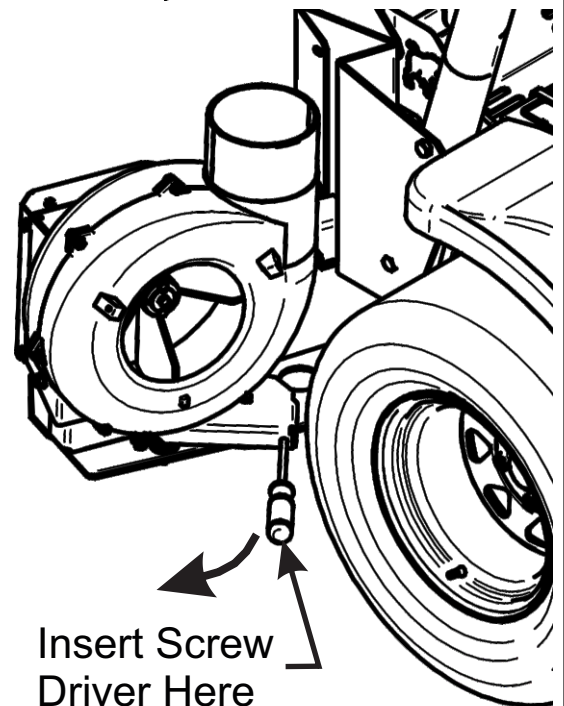
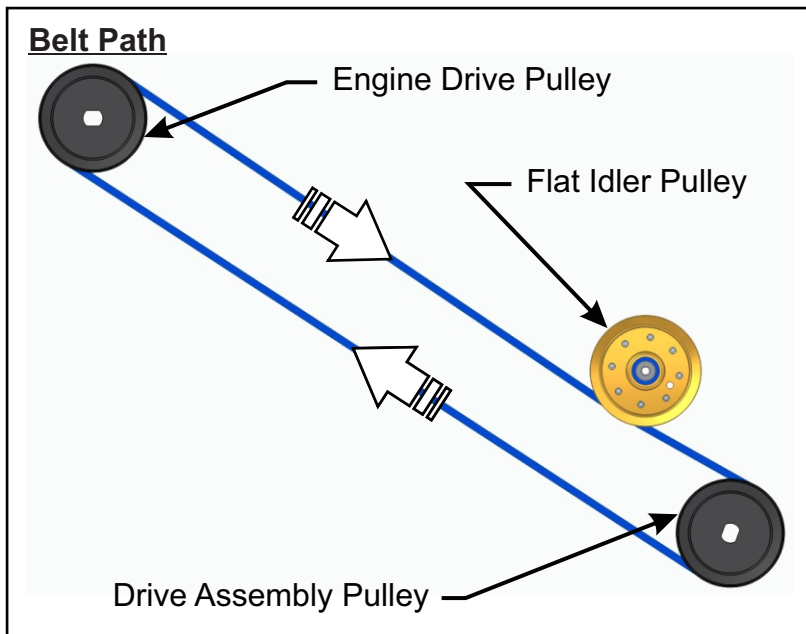
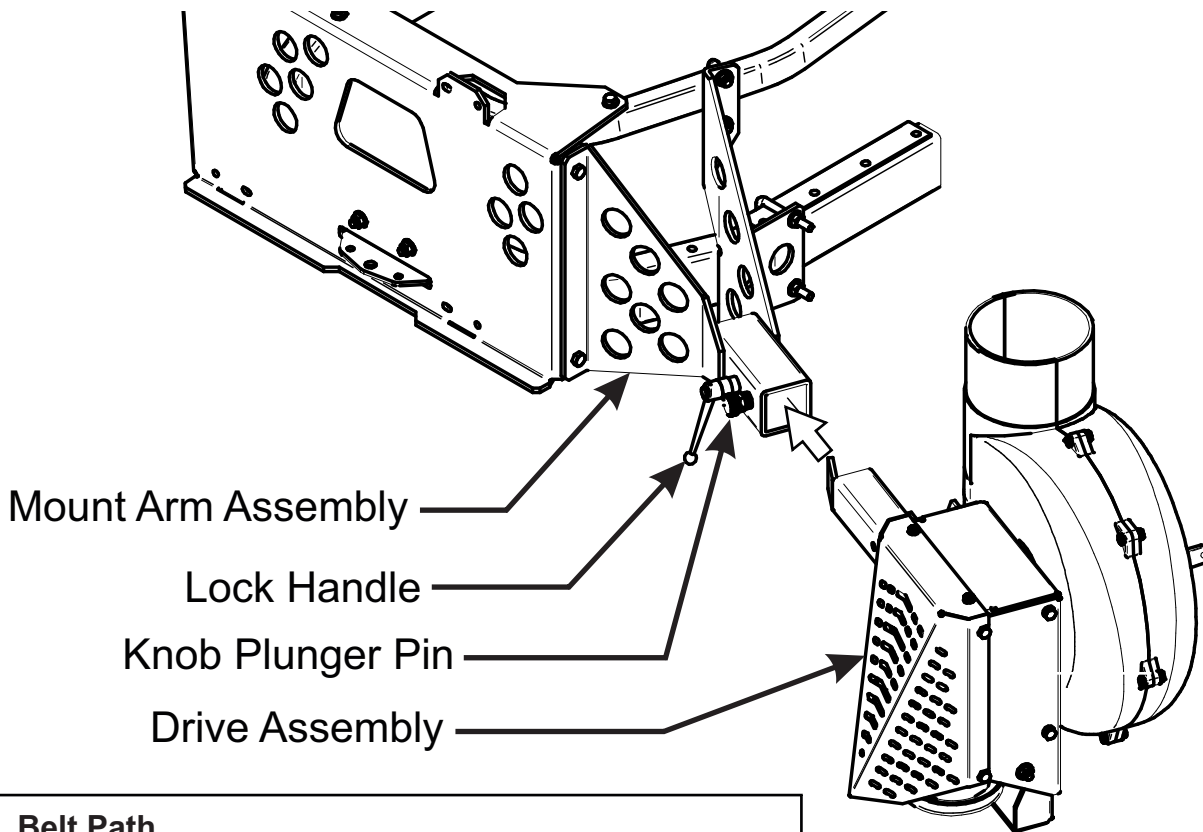

Blower Cone Installation

Thread (1) 5/16"-18 Jam Nut P#(K0120) onto each end of (2) 5/16"-18 x 2-1/2" HHCS P#(K0125) as shown in Figure A.

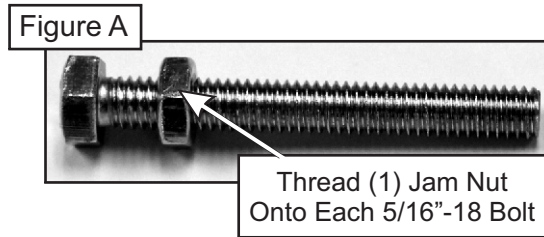

Now partially thread (1) bolt into each of the two threaded bosses located on the Blower Housing. Place 8" Blower Cone P#(E6009) so the two tabs line up with the bolts and tighten completely as shown in Figure B.

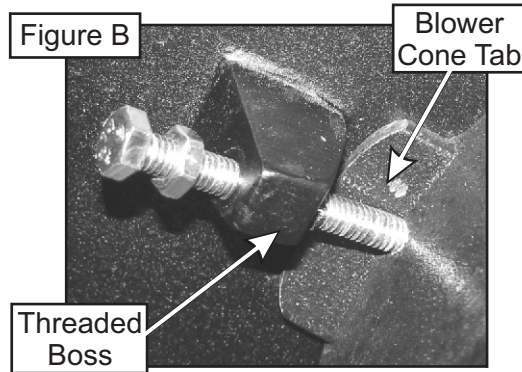

Once the (2) bolts are tight, tighten the Jam Nuts against the threaded boss as shown in Figure C.

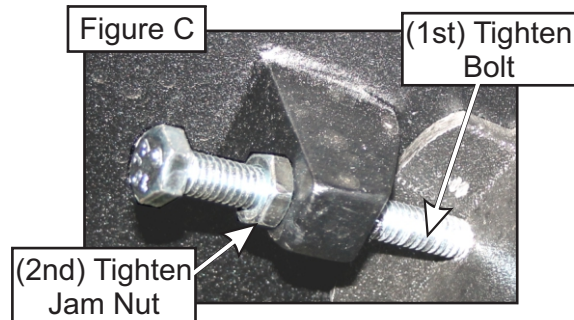

Refer to Figure D for proper Blower Cone installation reference.

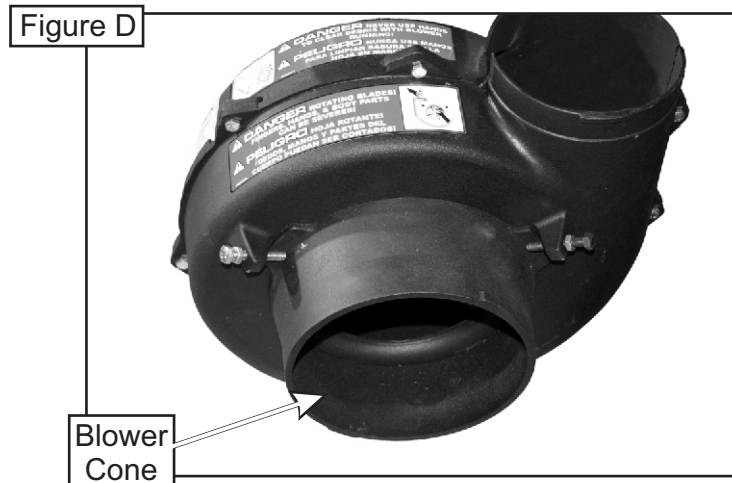

Boot Kit Installation

Step 1 - Loosen the mower's grass deflector mounting fasteners and attach the Deck Plate Assembly (Item #3) underneath.

Step 2 - Secure the Boot Plate Assembly (Item #2) and the Discharge Guard (Item#5) to the Aluminum Boot (Item #1) using (2) 3/8"-16 x 1" Carriage Bolts (Item #7) and (2) 3/8"-16 Ny-Flange Lock Nuts (Item #8). Insert the Carriage Bolts from the inside of the Boot so the threads are on the top of the Boot. This will prevent grass clippings from collecting on the threads. Leave the hardware loose until the boot plate has been attached to the mower deck. Refer to the Figure below.

Step 3 - Align Boot Plate Assembly Bushings to the Deck Plate Assembly Bushings.

Step 4- Insert Boot Rod (Item #4) through the Boot & Deck Plate Assembly Bushings.

Step 5 - Secure the Boot Rod using a Hair Pin Clip (Item #6).

Step 6 - With the Carriage Bolts (Item #7) & mower's grass deflector mounting bolts still loose, adjust the position of the boot so that there is no gap between the mower deck and the boot.

Step 7 - Tighten all hardware at this time.

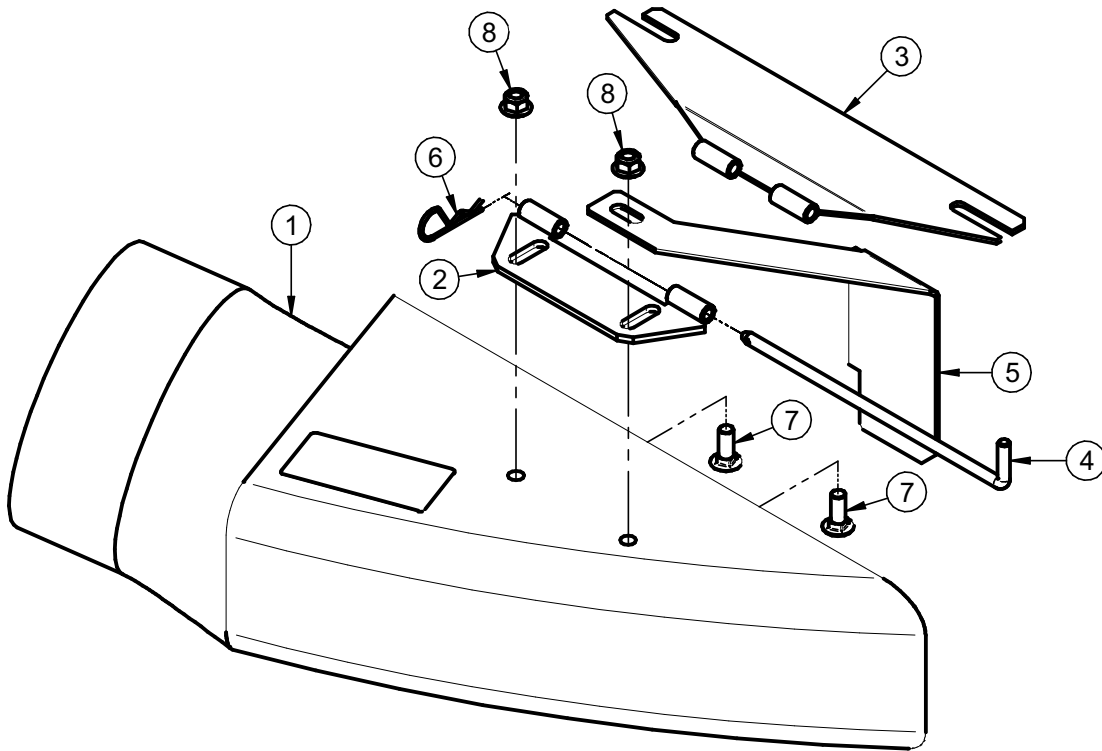

Item #	Part #	Desc.	Qty.
1	E0031A	Boot w/ Decal / Kubota	1
2	A1121	Boot Plate Assy.	1
3	A2118	Deck Plate Assy.	1
4	B0244	Boot Rod	1
5	B1064	Discharge Gaurd	1
6	K0099	Hair Pin Clip 3/32"	1
7	K1182	Carriage Bolt 3/8"-16 x 1"	2
8	K2038	Ny-Flange Lock Nut 3/8"-16	2

Lower Mount Tube Installation

Secure the (2) Lower Mount Tubes (Item #1) to the Rear Mount Plate using (2) 5/16"-18 U-Bolts (Item #3) and (4) 5/16"-18 Ny-Flange Lock Nuts (Item #4) PER TUBE. Refer to Figure A.

Upper Frame Assembly Installation

Position the Upper Frame Assembly (Item #2) above the Lower mount tubes as shown in Figure A Slide the Upper Frame Assembly down onto the Lower Mount Tubes and secure using (2) Clevis Pins (Item #5) and (2) Hair Pin Clips (Item #6).

Figure A

Item #	Part #	Desc.	Qty.
1	B0640	Lower Mount Tube / 29"	2
2	A2047	Upper Frame Assy / P2B+ Gen. 2	1
3	K1098	U-Bolt / 5/16"-18 x 2" x 2-1/2"	4
4	K2516	Ny-Flange Lock Nut 5/16"-18	8
5	K0133	Clevis Pin 1/2" x 2-1/2"	2
6	K0088	Hair Pin Clip 5/32" x 2-5/8" L	2

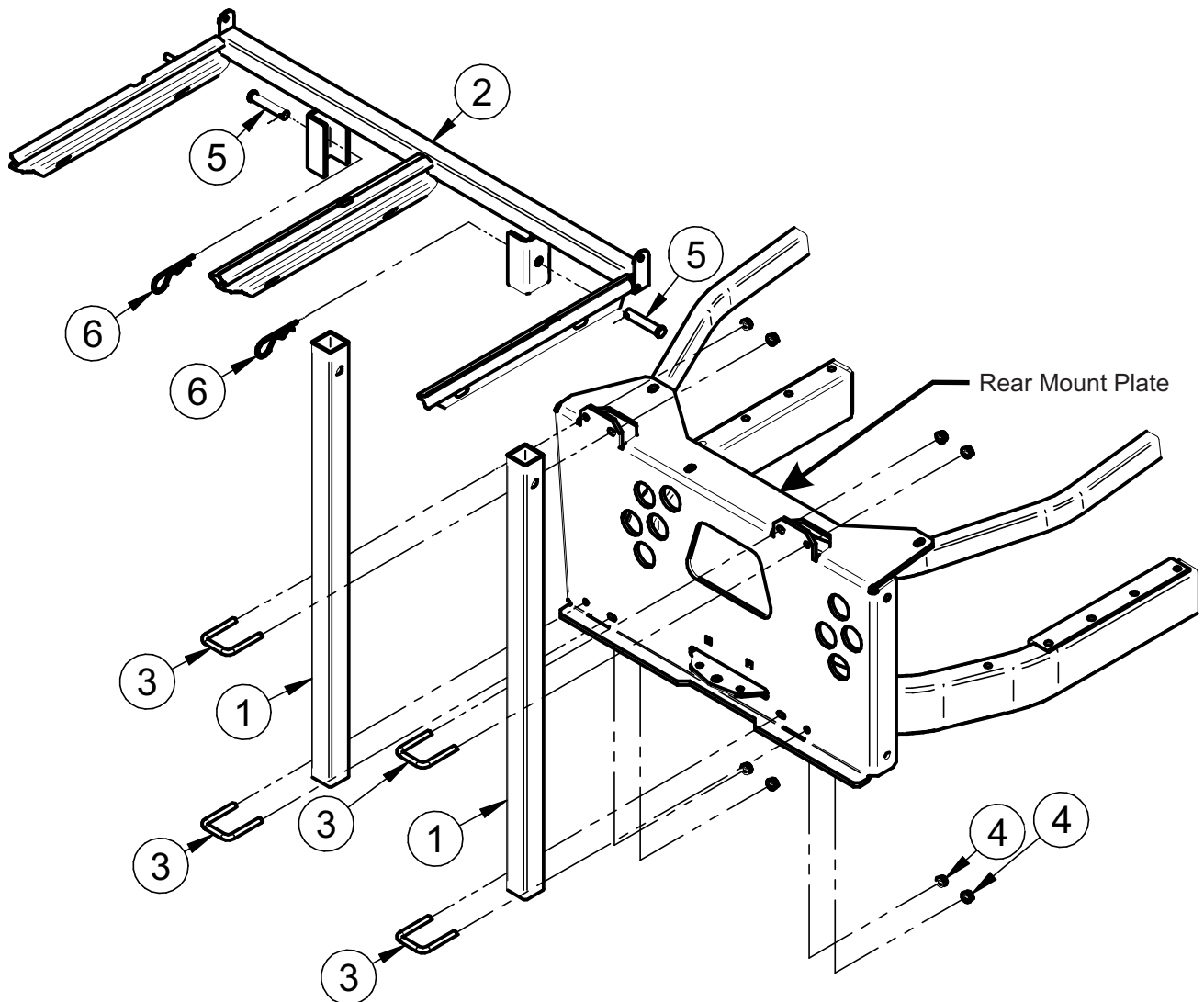

Top Assembly To Upper Frame Assembly Installation

Align the Top Assembly Pivot Holes to the Upper Frame Assembly. See Figure A below. Before fastening, pull Rubber Dust Guard outward to seal against Upper Frame Assembly (towards the mower's operator seat). Fasten the Top Assembly to the Upper Frame Assembly using (2) 5/16"-18 x 2-1/2" HHCS P#(K0125) and (2) 5/16"-18 Ny-Flange Locknuts P#(K2516). Leave the Ny-Flange Locknuts slightly loose to allow the Top Assembly to open and close easily.

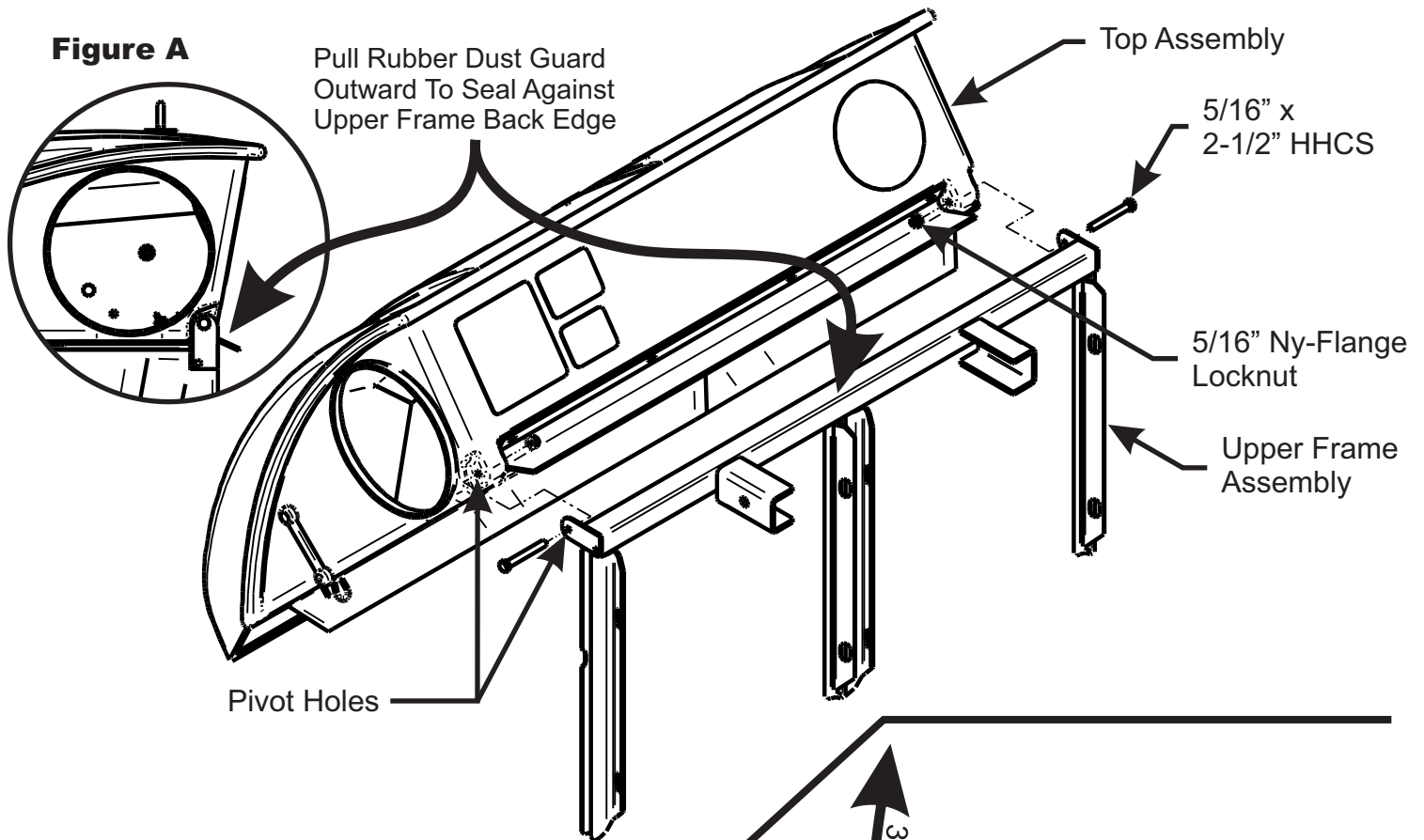

Inlet Installation

Position the Top Assembly on its side with the Inlet Hole facing up. See Figure B. 1: Insert the Inlet from inside the Top Assembly, up through the Inlet Hole, until the Inlet Retaining Lip meets the Inlet Hole. 2: Position the Inlet as shown in Figure B, then pull the Inlet until a portion of the Inlet Retaining Lip protrudes from the Inlet hole. 3: Next, lift the Inlet as shown in Figure B until all of the Inlet Retaining Lip protrudes from the Inlet Hole. Once installed, the Inlet should pivot freely about the Inlet Hole.

Figure B

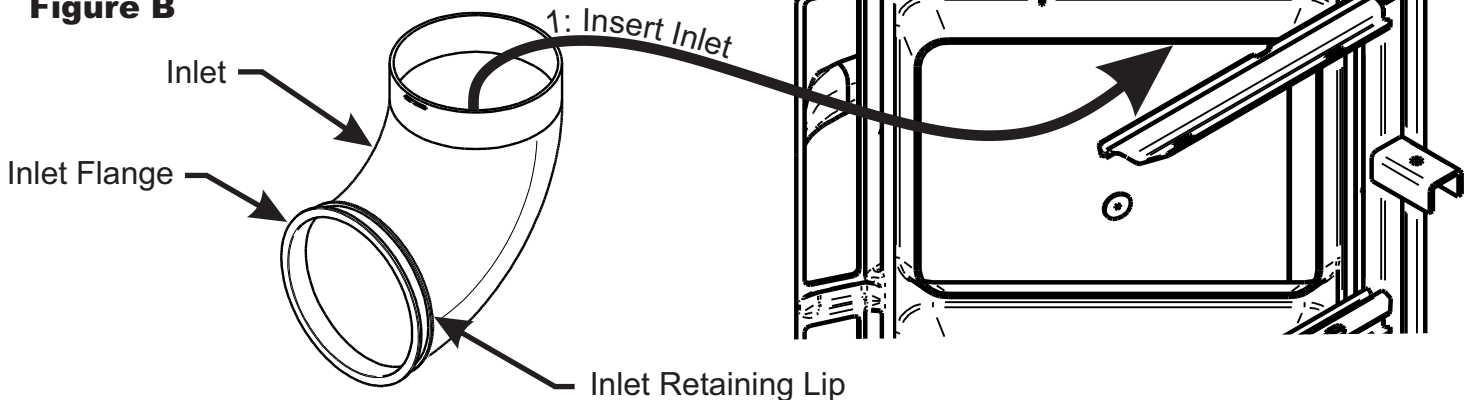

Hinge Kit Assembly Installation

Assemble the Hinge Kit using (1) Latch Plate P#(B0884), (1) 5/16"-18 x 1-1/4" HHCS P#(K1156), (1) 5/16"-18 Ny-Flange Lock Nut P#(K2516), (3) 5/16" Flat Washers P#(K0042), (1) Latch Spacer P#(S0006), (2) Extra Heavy 5/16" Fender Washers P#(K0505) and (1) 5/16"-18 Lock Nut P#(K0506). Leave the nuts loose enough to allow fluid movement of the top when opening and closing. When opened, the top should rest in the Latch Plate Slot.

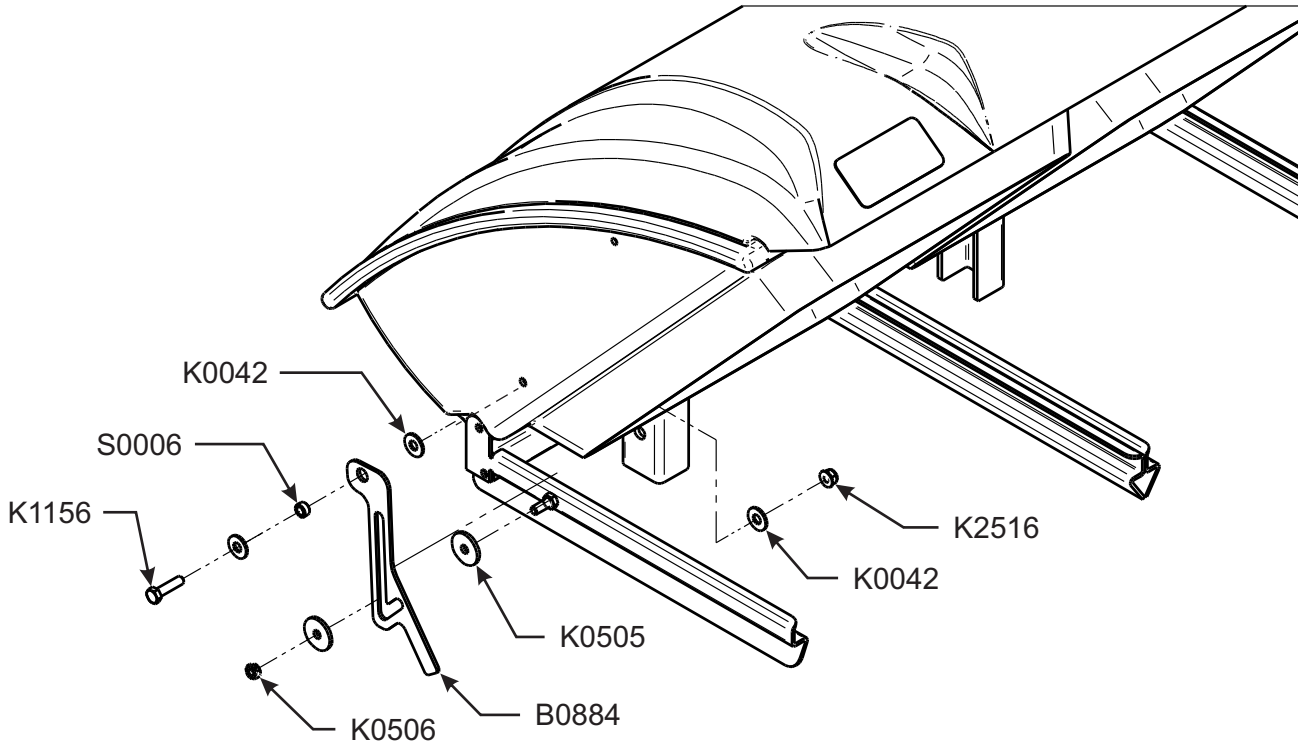

Even Bag Fill Adjustment

Flap can be adjusted Up/Down depending on mowing conditions. Adjust flap up to allow more dense material to reach left bag. Adjust flap down to allow less dense material to reach the right bag. Once adjusted properly, both bags should fill evenly, but may require further adjusting when mowing conditions change.

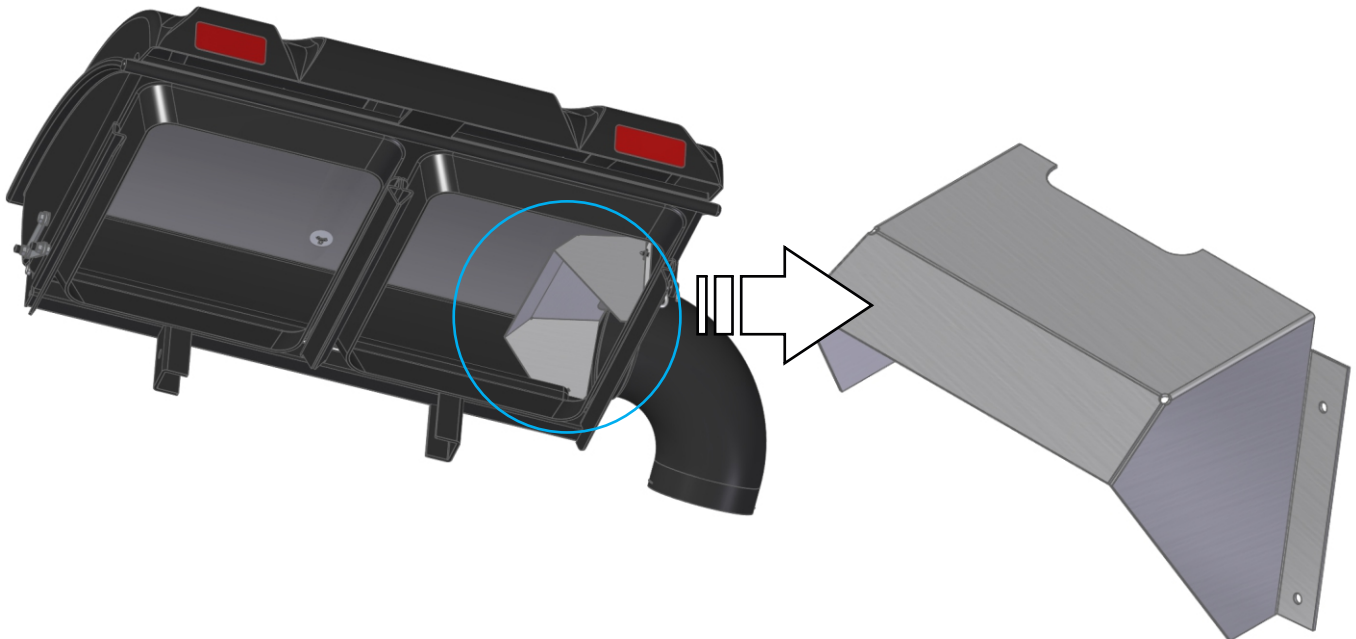

Bag Assembly

First, take one of the Bag Ring Split Ends and insert it through the Bag Seam Opening. Next, rotate the Bag around the Bag Ring (1) full turn (360 degrees) until the Bag Ring Split Ends and the Bag Seam Opening are positioned on the same side. Then, connect the Bag Ring Split Ends using (1) End Connector. Last, rotate the Bag Ring and the End Connector Assembly (1/2") turn (180 degrees) to position the Connector opposite of the Bag Seam Opening. Note Final End Connector Location below in Figure A. Repeat for each Bag.

Figure A

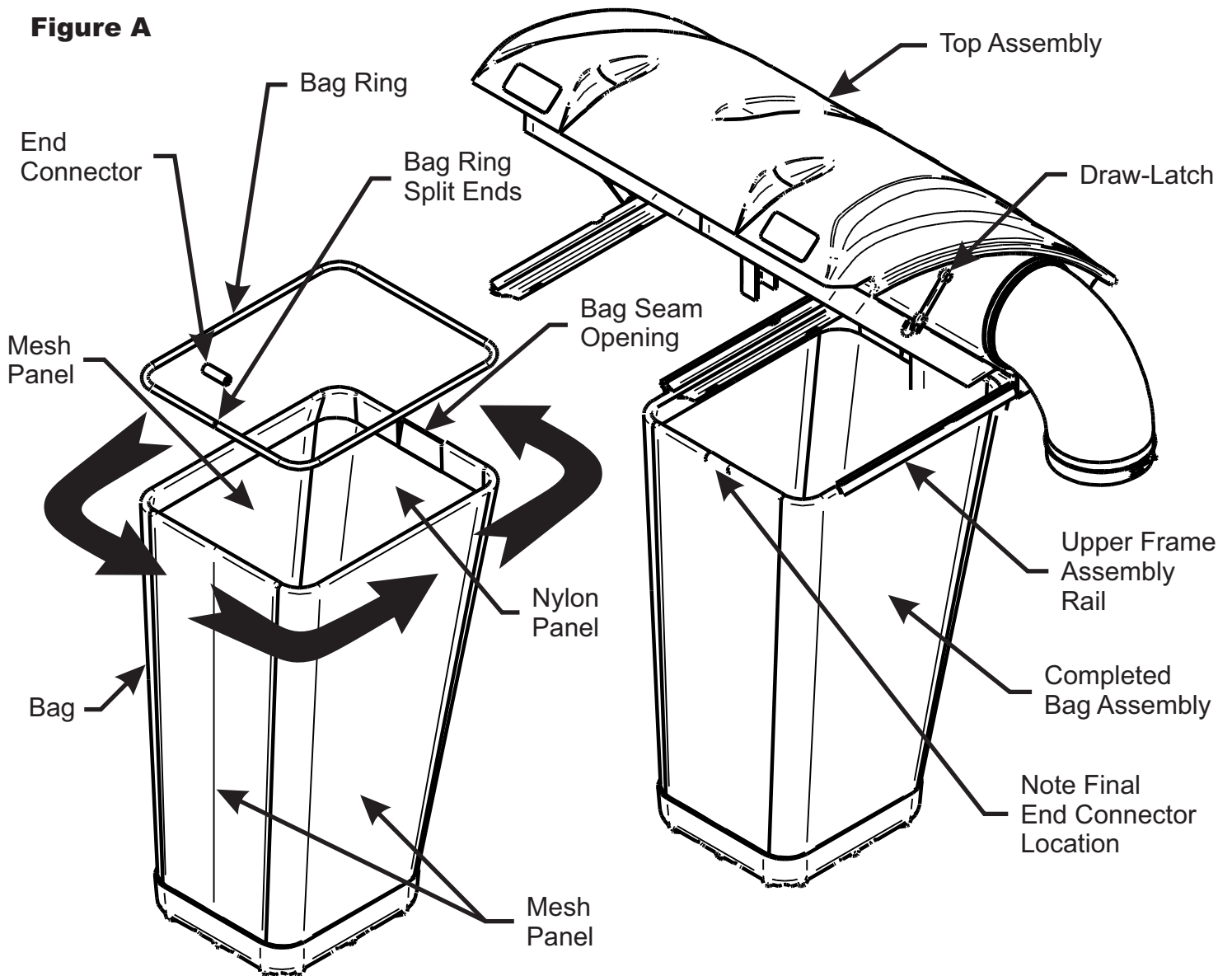

Bag Assembly Installation

Slide the Completed Bag Assembly into the Upper Frame Assembly Rails and close the Top Assembly. Fasten the Draw-Latch on either side to hold the bagger closed.

Length Of Hose Adjustment

The hoses in the following steps must be cut to fit your machine. Do not cut the hoses until you have tried to fit them on your machine. Remember that the hoses need to be long enough to allow for the opening and closing of the collection system as well as allowing ample clamping surface between each component.

Upper Hose Installation

Slide a Hose Clamp P#(J0060) over one end of the 6" Upper Hose. Secure this end of the 6" Upper Hose to the Blower Outlet. See Figure below for details. Secure opposite end of the 6" Upper Hose to the Inlet. Make sure both ends are securely fastened by tightening the Hose Clamp and rotating the Inlet Snap Fastener towards the hose to lock in place.

Lower Hose To Blower Cone Installation

Slide a Hose Clamp P#(J0080) over both ends of the Lower Hose. Secure one end of the Lower Hose to the Blower Cone and fasten by tightening the Hose Clamp.

Lower Hose To Boot Installation

Take the unattached end of the Lower Hose and secure it to the circular end of the Boot and fasten by tightening the Hose Clamp.

Tip: Before securing Hose Clamp fully, rotate Lower Hose counter-clockwise (away from yourself) approximately 1" to aid in retaining Boot to mower deck.

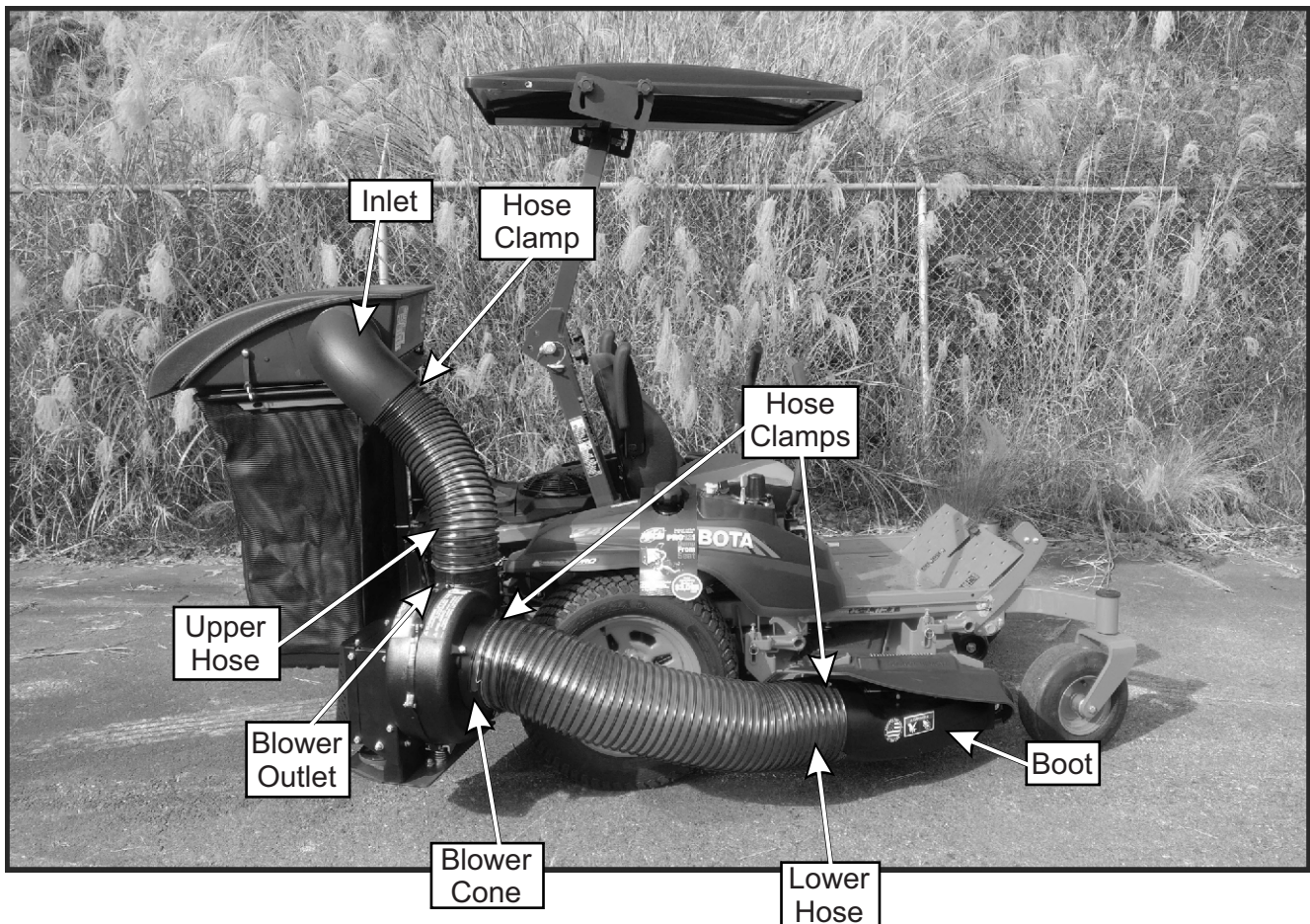

Safety Interlock Wiring Harness Installation

Follow the steps below to correctly install the Safety Interlock Wiring Harness to the mower.

Part #	Description	Quantity
P0275	Wiring Harness w/ PTO Switch	1
J0245	Zip-Tie	5
B1029	Switch Mount	1

1 Route Depicted Harness Male/Female Brake Switch Connectors Through Hole Underneath Seat Towards Mower Front



WARNING

To Prevent Serious Injury-
Proper Installation Of Safety Interlock Harness Is Mandatory. Please Check That All Interlock Points Work Correctly Once Installed.

2 Route Depicted Harness PTO Switch Connector Through Same Hole Towards Mower Front

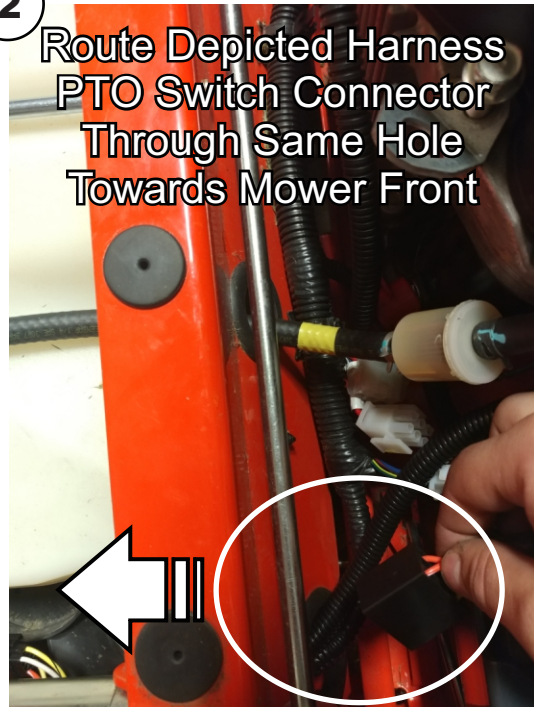

3 Disconnect Mower's Brake Switch Located On Left Side Of Mower

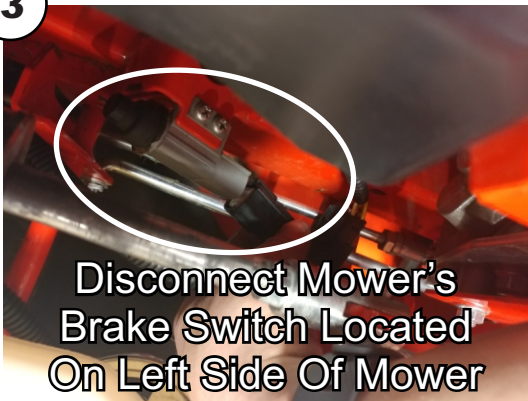

4 Interconnect Harness Brake Switch Connectors



5 Mount Switch Plate Behind Mower's Hydro Reservoir, Then Connect PTO Switch & Harness PTO Switch Connector

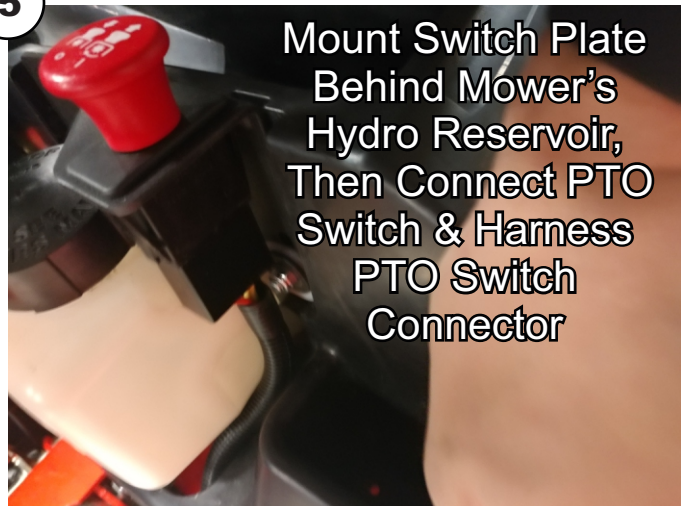

Safety Interlock Wiring Harness Installation (Continued)

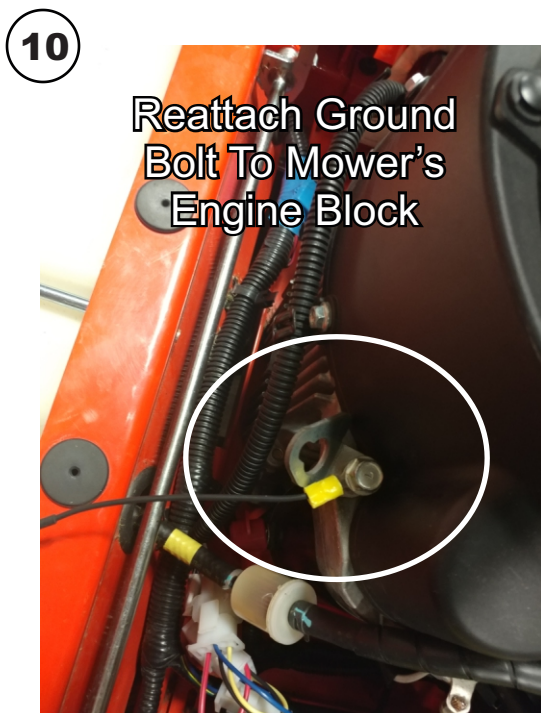
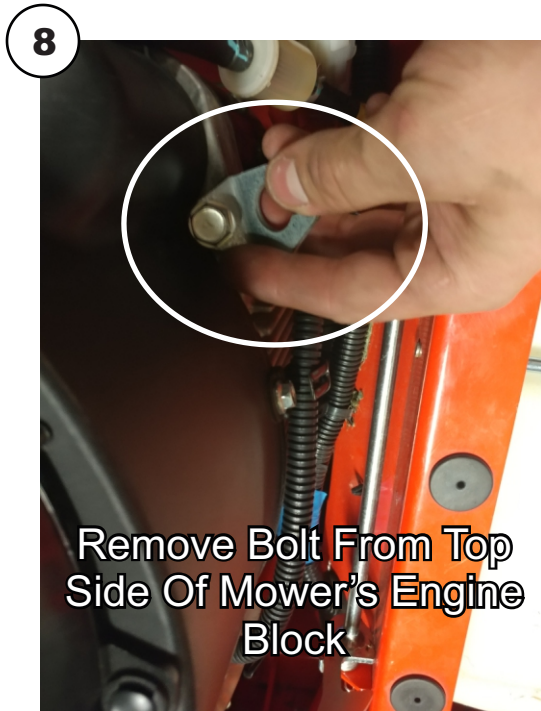
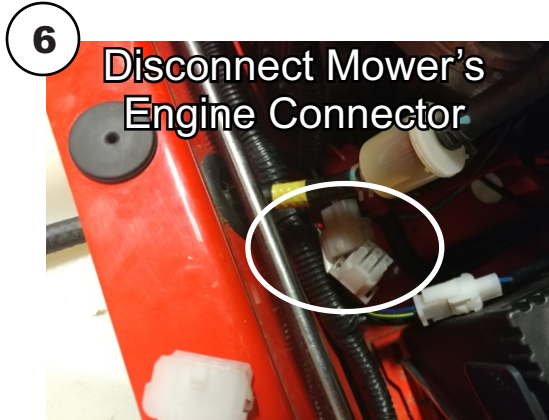

Safety Interlock Wiring Harness Installation (Continued)

12

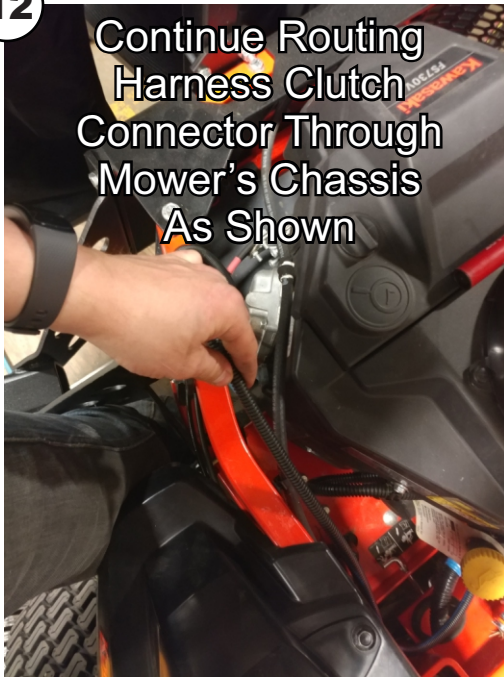

Continue Routing
Harness Clutch
Connector Through
Mower's Chassis
As Shown

13



Continue Routing
Harness Clutch
Connector Towards
PTO Drive Clutch
Connector

14



Connect Harness Clutch
Connector To PTO
Drive Clutch Connector

15



Zip-Tie Harness To
Mower's Harness
As Shown To
Prevent Damage To
Mower & Harness

16



Zip-Tie Harness To
Mower's Rear Chassis
As Shown To Prevent
Damage To Mower
& Harness

17



Zip-Tie Harness To
Mower's Rear Chassis
To Prevent Damage To
Mower & Harness

Impeller Blade Removal/Replacement

To Remove: First remove the 5/16"-24 x 1" HHCS P#(K0428) (#1), Taper Lock Bushing Washer P#(K0284) (#3), (2) 5/16 Flat Wahers P#(K0042) and Spacer Bushing P#(S0159) (#4) from the Taper-Lock Bushing P#(S0157) (#5). Next remove the (2) 1/4"-20 x 1" HHCS (#2) and place them into the threaded holes of the Taper-Lock Bushing (#5). Gradually thread each bolt evenly into the Taper-Lock Bushing, forcing the blade to break-away from the Taper-Lock Bushing. If the Impeller will not move, carefully hit the base of the Impeller, between each vein, with a hammer, then try again.

To Replace: Place Impeller Blade over the engine shaft. Slide the Taper-Lock Bushing (#5) on to the engine shaft and into the Impeller Blade, aligning the **non-threaded** holes of the Taper-Lock Bushing to the threaded holes of the Impeller Blade. Fasten by using (2) 1/4"-20 x 1" HHCS (#2), (1) Spacer Bushing (#4) (1) Taper-Lock Bushing Washer (#3), and (1) 5/16"-24 x 1" HHCS (#1). Torque to the proper specifications in the torque chart on the back of this manual. Next, rotate the Impeller Blade to ensure that the blade is clear of contact on all sides of the blower housing.

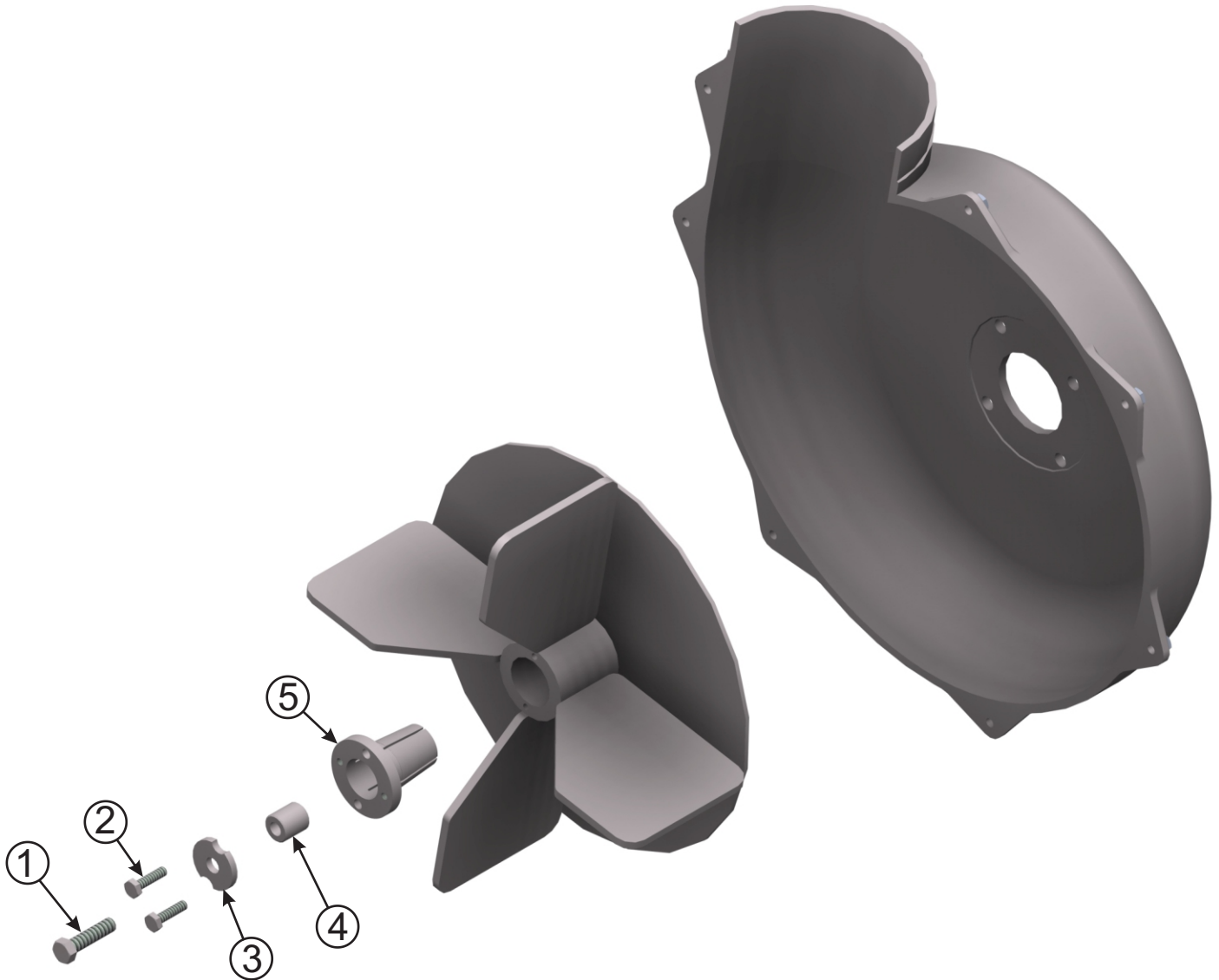

Weight Kit Installation

Step 1 - Position (#2) Base Under Caster Tubing w/ Opening Towards Caster Fork.

Step 2 - Position (#3) Clamp On Top Of Caster Tubing w/ Opening Towards Caster Fork.

Step 3 - Align (4) Holes In (#3) Clamp To Holes In (#2) Base

Step 4 - Loosely Fasten (#3) Clamp To (#2) Base Using (4) (#4.1) 5/16"-18 x 3" Bolts & (4) (#4.2) 5/16"-18 Ny-Flange Lock Nuts.

Step 5 - Position (#2 & #3) Assembly Along Caster Tubing To Prevent Interference From Caster Forks Or Any Other Objects. Tighten Fasteners In An 'X' Pattern Until Assembly Is Firmly Clamped To Caster Tubing. Do Not Over tighten Resulting In Bending (#3) Clamp.

Step 6 - Insert (#1) Weight Into (#2) Base & Align Hole In Weight w/ Holes In (#2) Base.

Step 7 - Fasten (#1) Weight To (#2) Base Using (1) (#4.3) Clevis Pin & (1) (#4.4) Hair Pin Clip. Repeat For Additional Weights.

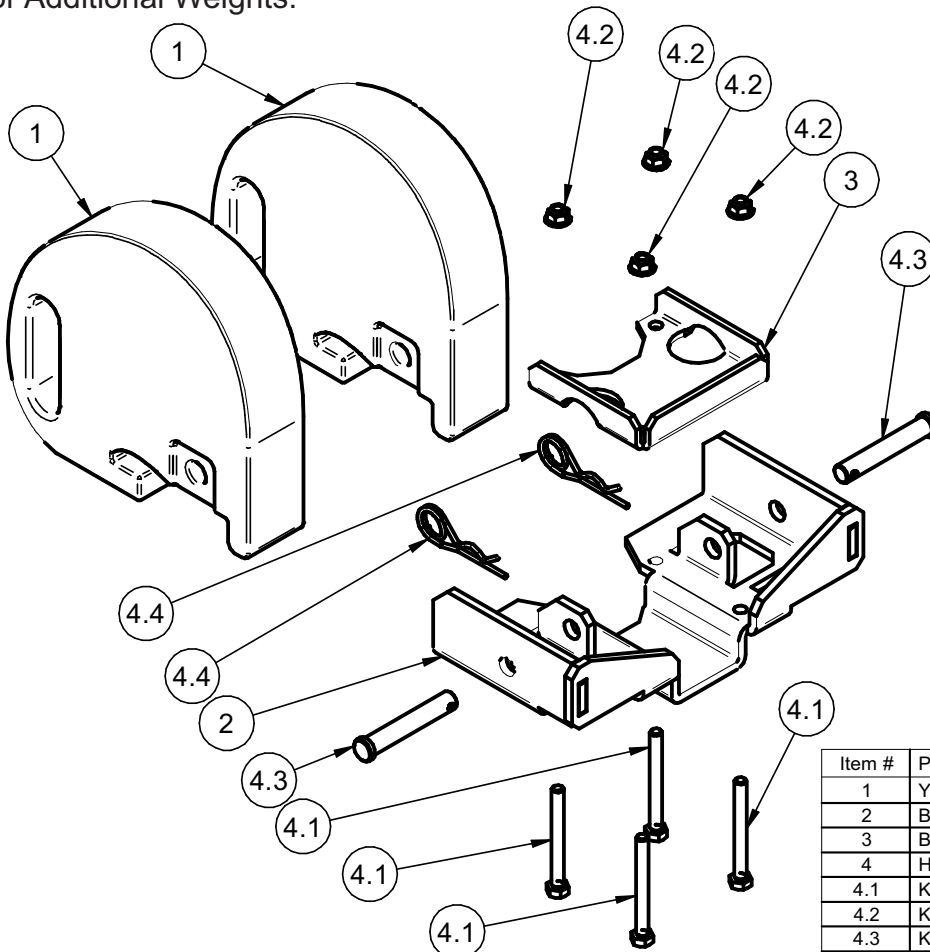
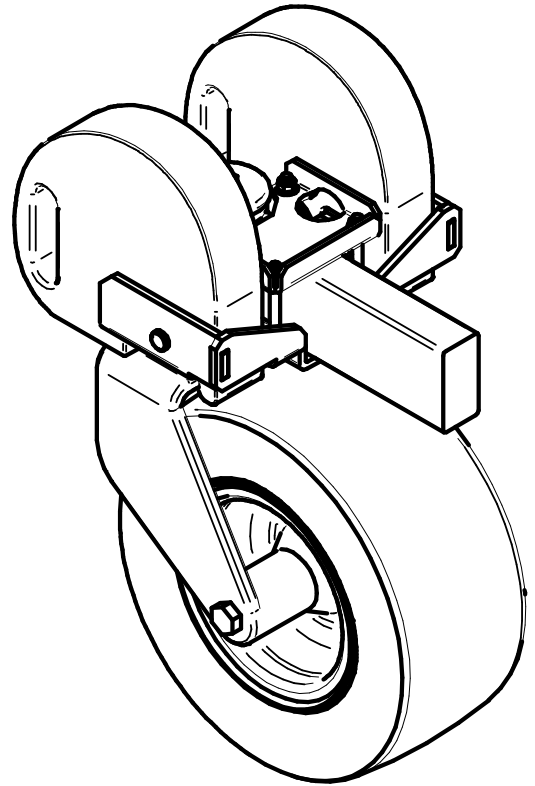

Item #	Part #	Desc.	Qty.
1	Y0025	28 lb. Suitcase Weight	2
2	B1014	Dual Weight Bracket / Base	1
3	B1015	Weight Bracket / Clamp	1
4	HB0687	Dual Weight Kit Hardware Bag	1
4.1	K1472	HHCS 5/16"-18 x 3" GR5	4
4.2	K2516	Ny-Flange Lock Nut 5/16"-18	4
4.3	K1473	Clevis Pin 1/2" x 3"	2
4.4	K1478	Hair Pin Cotter / Double Loop	2

A2127 Mount Arm Assembly

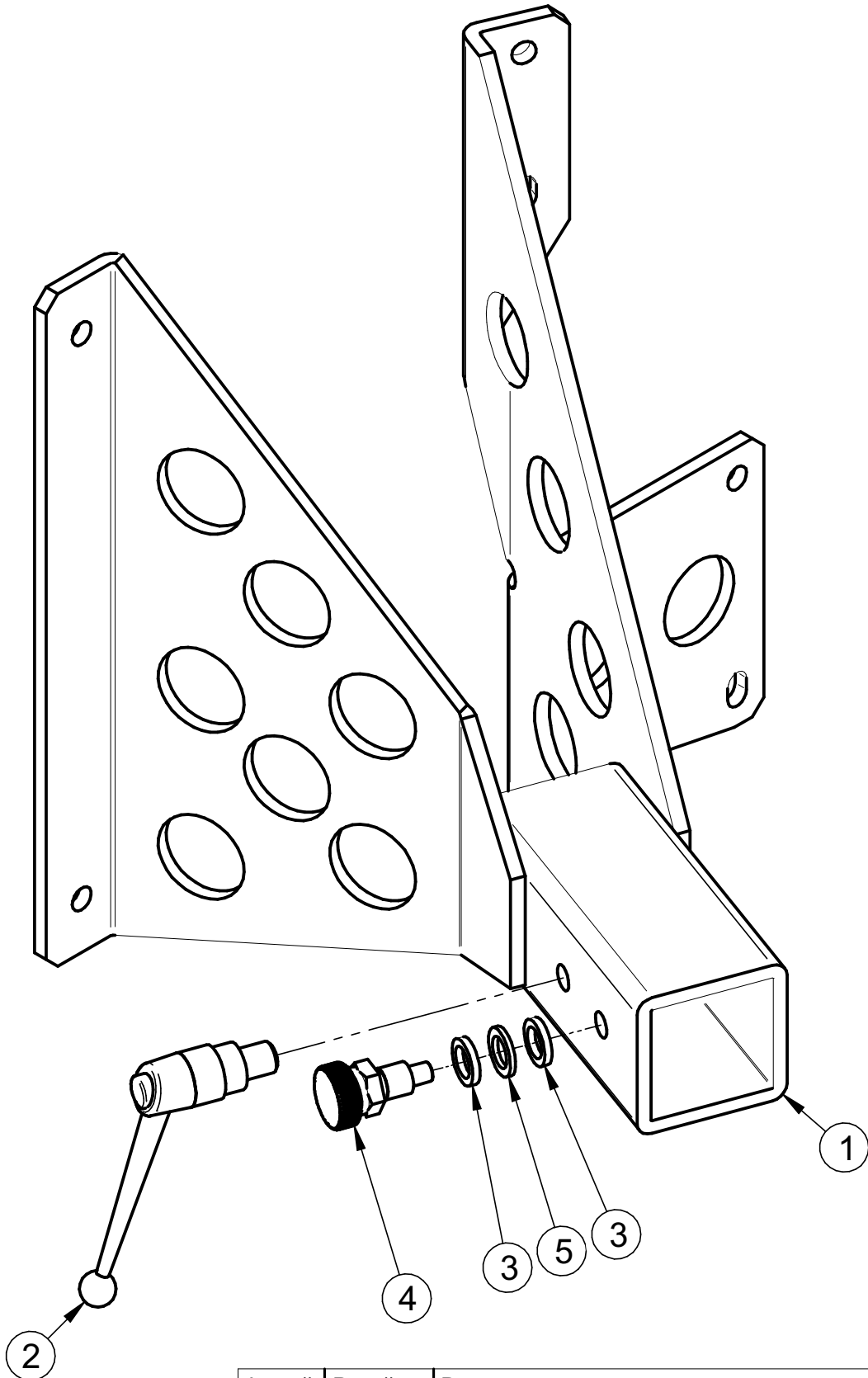

Item #	Part #	Desc.	Qty.
1	A2117	Mount Arm Sub-Assy.	1
2	J0009	Adjustable Handle 1/2"-13 x .59 Male	1
3	J0013	Nylon Flat Washer 1/2" x .750" OD Grade 6/6	2
4	J0020	Knob Plunger Pin 1/2"-13	1
5	K0027	Flat Washer 1/2" / .787 OD x .512 ID x .090 T	1

A2092 Idler Arm Assembly

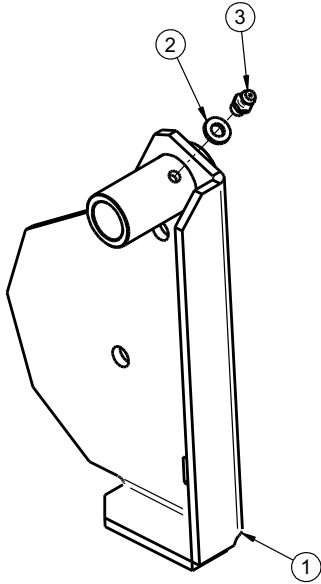

Item #	Part #	Desc.	Qty.
1	A2070_01	Idler Arm Weldment	1
2	K1467	Flat Washer M6 x 12mm OD	1
3	J0801	1/4"-28 Zirc Fitting	1

A2067_02 Idler Mount Assembly

Item #	Part #	Desc.	Qty.
1	B0958_02	Idler Mnt Pl	1
2	K2038	Ny-Flange Lock Nut 3/8"-16	2
3	K1463	Flat Washer .720 ID x 1.500 OD x .250 T	2
4	K1219	Jam Nut 3/8"-16	1
5	K1192	HHCS 3/8"-16 x 1-1/4" GR5	1
6	K0329	Nylock Nut 7/16"-14 GR8	1
7	M0003	Idler Pulley	1
8	K1462	HHCS 3/8"-16 x 1-3/4" GR8	1
9	K1464	Shoulder Bolt 7/16"-14 / Idler	1
10	J0024	Torsion Spring	1
11	A2092	Idler Arm Assy	1
12	B0974	Idler Base Plate	1

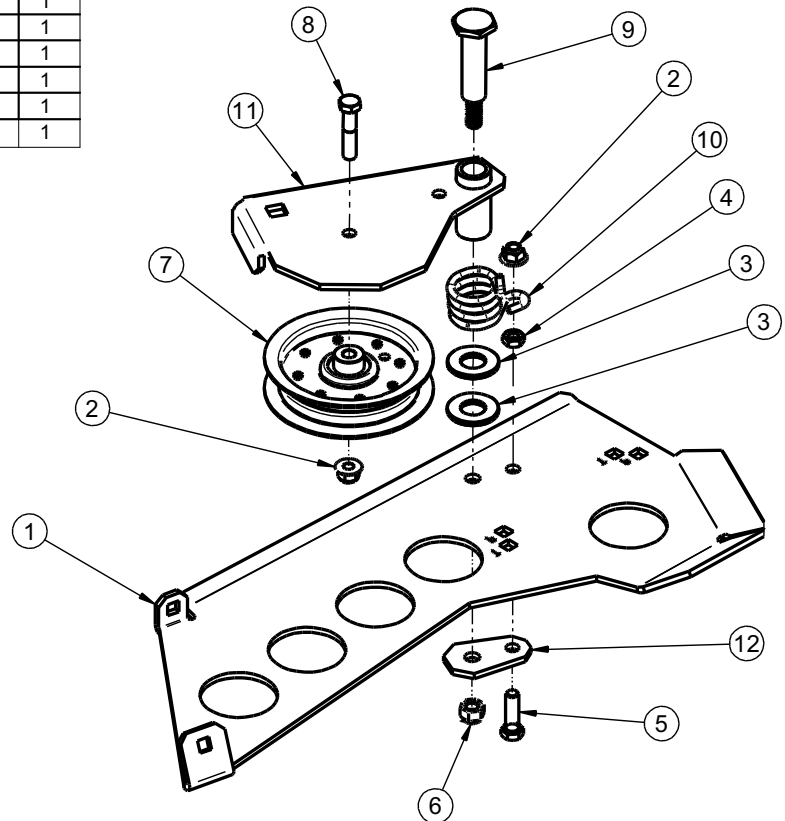

A2058 Gearbox Sub-Assembly

Item #	Part #	Desc.	Qty.
1	M0002	Gearbox	1
2	K0428	HHCS 5/16"-24 x 1" GR8	1
3	K0043	Lock Washer 5/16"	1
4	N0002	Pillow Block Bearing 7/8"	1
5	K0035	Set Screw 5/16"-18 x 1/4" Cup Point	1
6	J0272	Woodruff Key #9	1
7	A2048	Clutch Flange	1

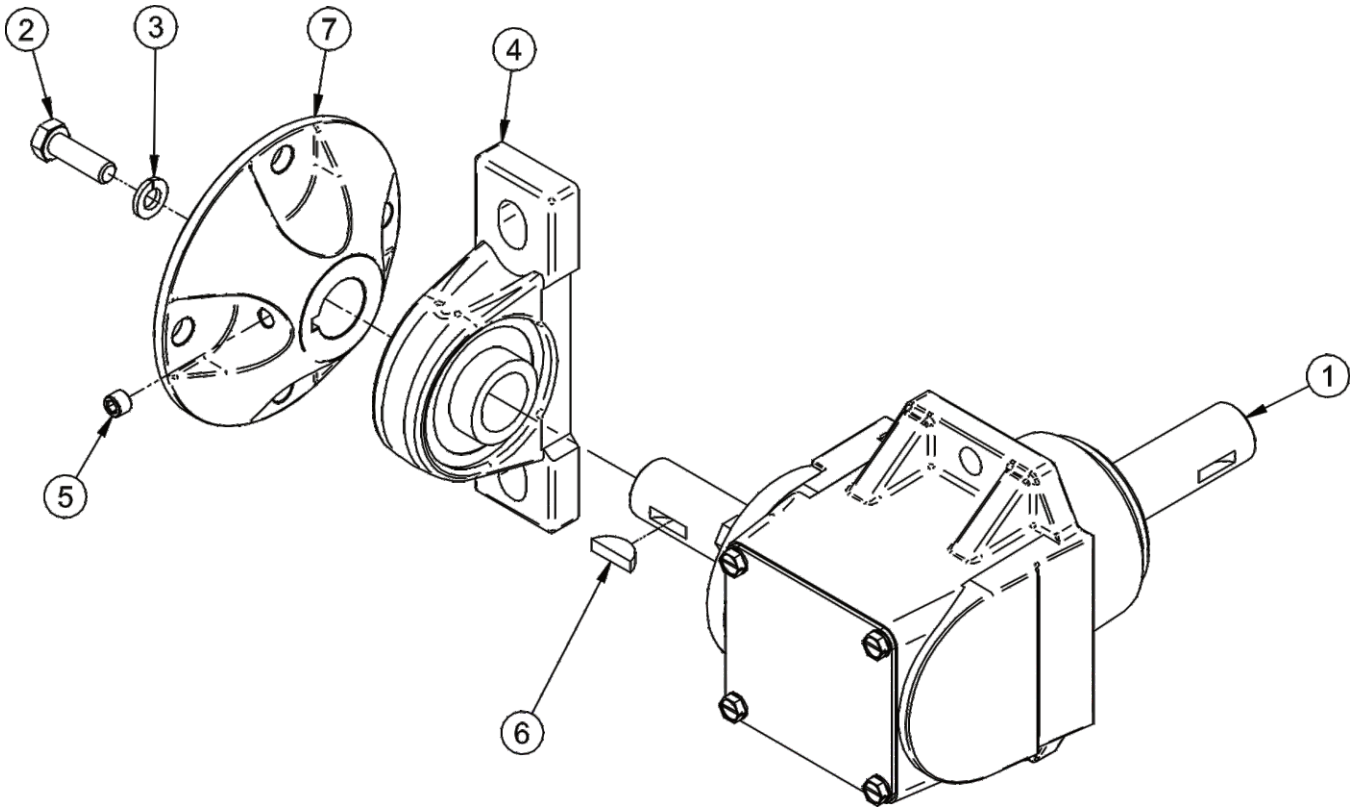

A2059_01 Clutch Sub-Assembly

Item #	Part #	Desc.	Qty.
1	M0001	Electric Clutch	1
2	S0007	Clutch Shaft	1
3	K0278	Double Indented Washer 7/16" / 1.375 OD x .440 ID x .179 T	1
4	K0140	Lock Washer 7/16" / High-Collar Helical Spring	1
5	K0359	HHCS / 7/16"-20 x 3.50" w/ Patch	1
6	M0309	A-Section Pulley / 4.75 OD (PTO-X)	1
7	S0221	Eng. Pulley Bushing #27	1
8	K0076	Key 1/4" x 3/4" Long	1

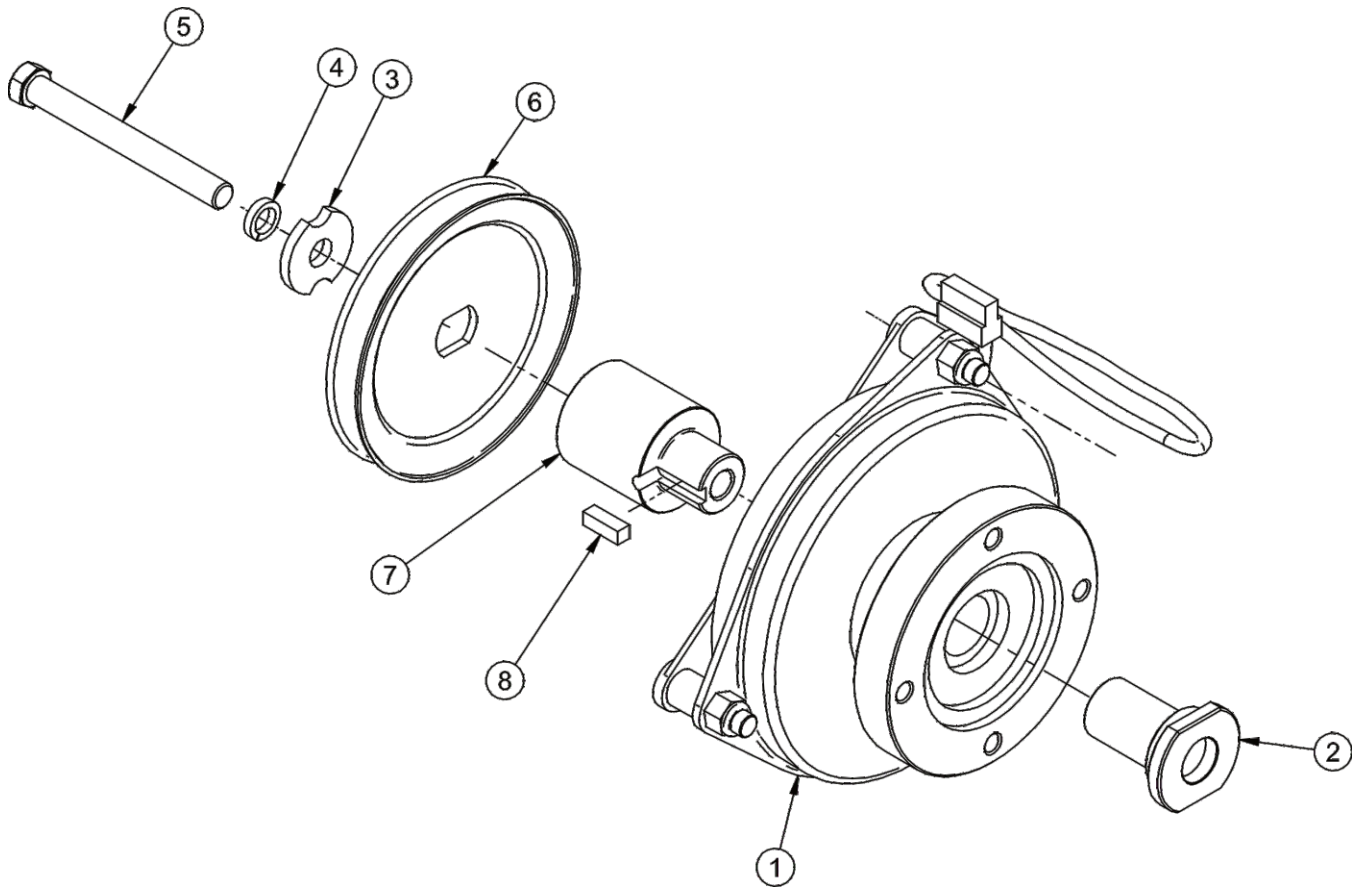

A2057_01 Drive Assembly Exploded Parts View

Item #	Part #	Desc.	Qty.
1	K0048	Lock Washer 3/8"	4
2	K0343	HHCS 3/8"-16 x 7/8" GR8	4
3	A2059_01	Clutch Sub-Assy	1
4	A2058	Gearbox Sub-Assy	1

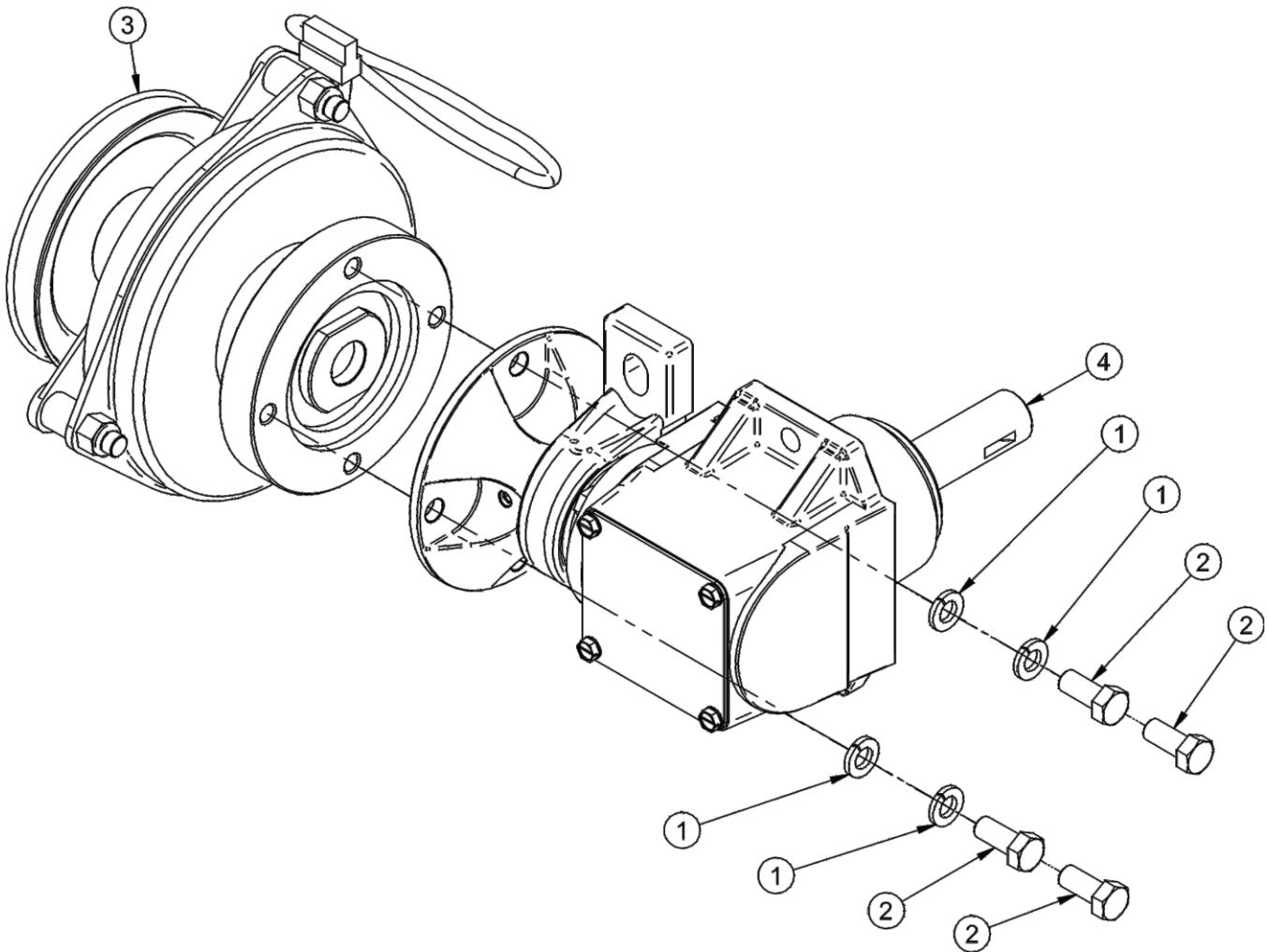

A2060_01 Mounted Drive Assembly

Item #	Part #	Desc.	Qty.
1	B0940	Spacer Plate	1
2	A2034	Drive Mnt Assy	1
3	K0309	3/8"-16 x 1-1/4" SHCS	2
4	K0048	Lock Washer 3/8"	2
5	K0055	Flat Washer 1/2" / 1.383 OD x .560 ID x .120 T	2
6	K0056	Lock Washer 1/2"	2
7	K1234	HHCS 1/2"-13 x 2"	2
8	A2057_01	Drive Assy	1

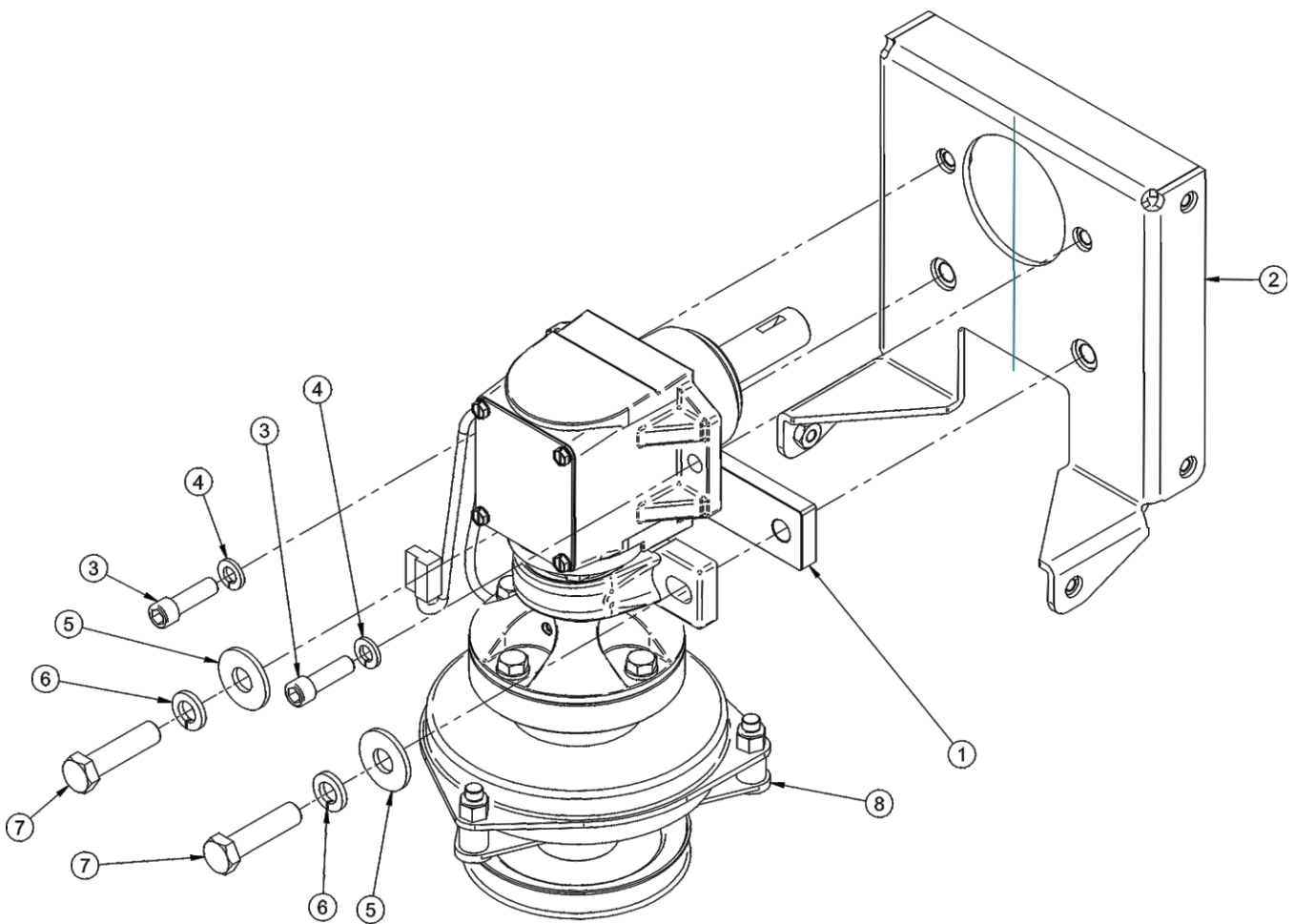

A2039_02 Base Drive Assembly

Item #	Part #	Desc.	Qty.
1	B0938_01	Drive Guard	1
2	A2032	Drive Arm Assy	1
3	A2035_02	Housing Mnt Assy	1
4	B0942_02	Anti-Rotation Brkt	1
5	K1153	HHCS 5/16"-18 x 3/4"	4
6	K0043	Lock Washer 5/16"	8
7	K0353	HWHTCS 1/4"-20 x 1/2"	2
8	K1154	HHCS 5/16"-18 x 1"	4
9	K2516	Ny-Flange Lock Nut 5/16"-18	4
10	A2060_01	Mounted Drive Assy	1
11	P0271	Quick Connect Wire Harness	1
12	K1142	5/16"-18 x 3/4" Carriage Bolt	4
13	K0343	HHCS 3/8"-16 x 7/8" GR8	1
14	K1477	Flat Washer / 3/8" / .406 ID x .812 OD x .125 Thk	1
15	K1476	Reverse Lock Nut / 3/8"-16 Grade C	1
16	B1100	Idler Assy Mount Plate	1

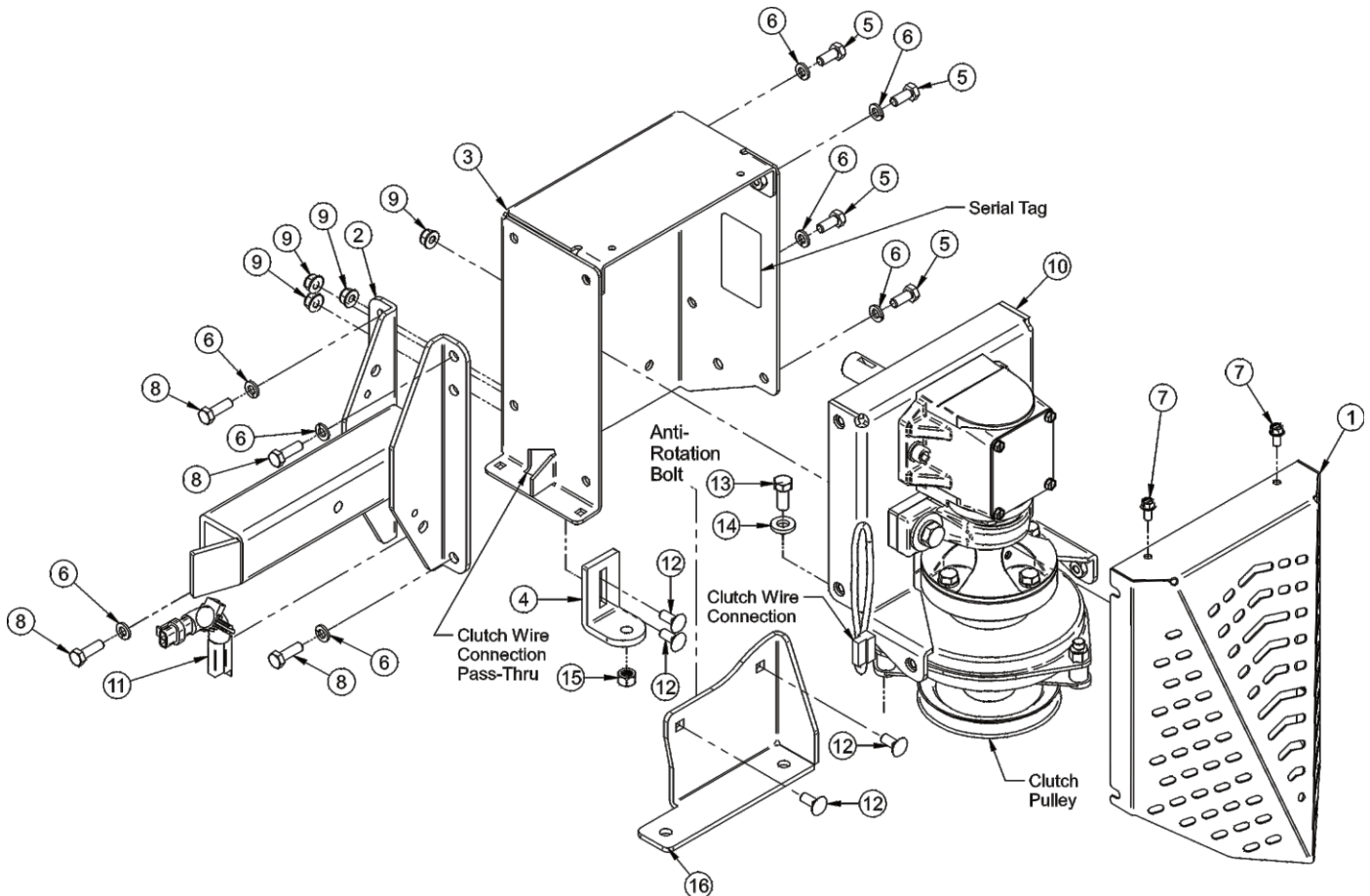

A2061 02 Drive Assembly / 4 Blade Impeller

Item #	Part #	Desc.	Qty.
1	A0645	4-Blade Impeller Weldment	1
2	K0284	Double Indented Washer 3/8" / 1.375 OD x .380 ID x .179 T	1
3	K1465	HHCS 5/16"-24 x 1-1/2" GR8	1
4	K1225	HHCS 1/4"-20 X 1" GR8	2
5	S0159	Spacer Bushing .938 OD x .325 ID x .375 T	1
6	K0044	I/T Tooth Lock Washer 5/16"	4
7	K1154	HHCS 5/16"-18 x 1"	4
8	A2039_02	Drive Assy / Base	1
9	S0157	Taperlock Bushing 7/8"	1
10	K0042	Flat Washer 5/16" / .875 OD x .380 ID x .075 T	2
11	E4052A	Blower Hsg Assy	1
11.1	E4052F	Blower Hsg Front	1
11.2	E4052B	Blower Hsg Back	1
11.3	HB0462	HW Bag / E4004A & E4052A Housings	1
11.3.1	K1401	1/4"-20 x 1" SHCS / Zinc / GR8	7
11.3.2	K1126	Flange Nut 1/4"-20	7

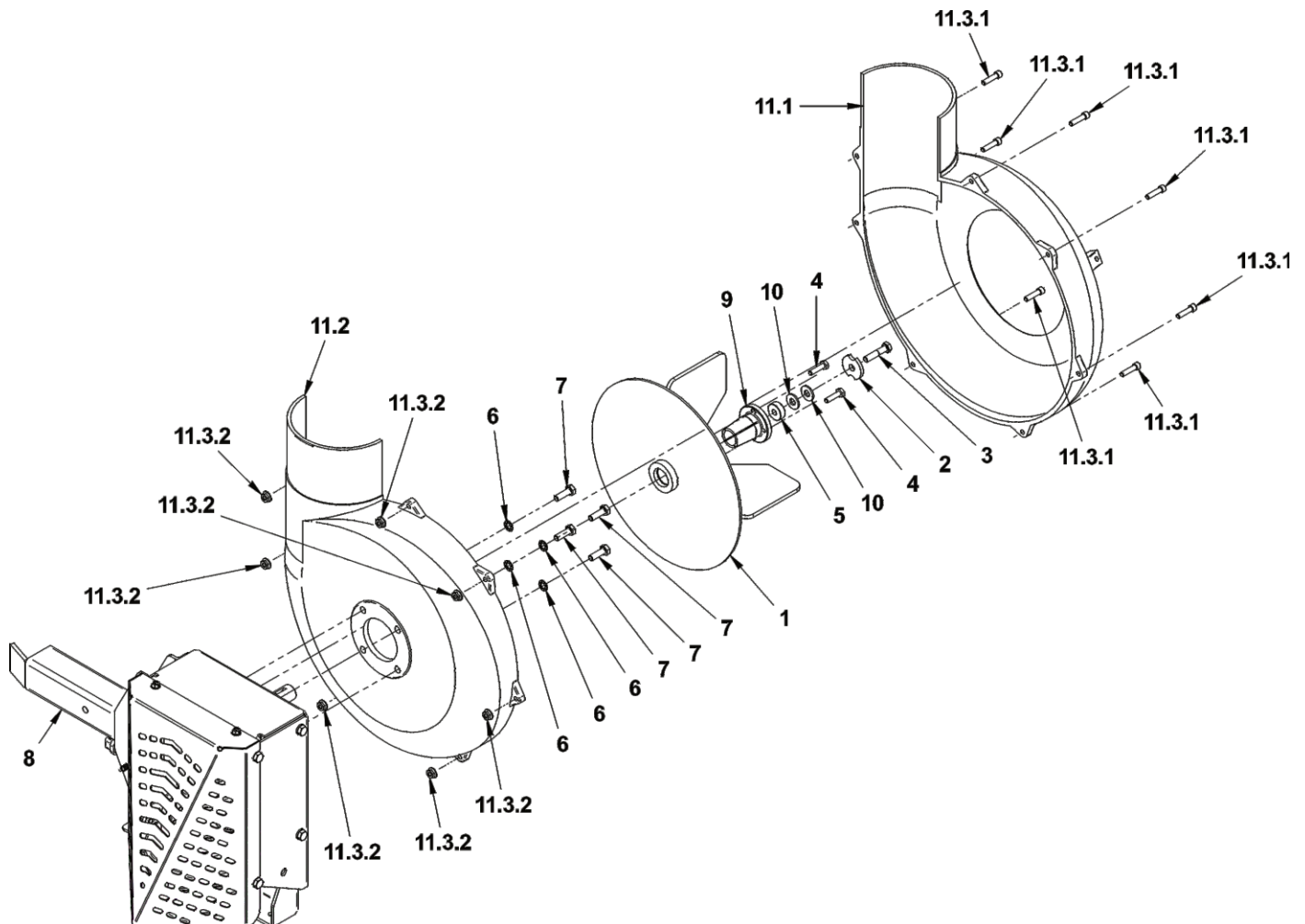

A2101 Top Assembly Exploded Parts View

Item #	Part #	Desc.	Qty.
1	V2000	Pro 2 Bagger Top / Gen. 2	1
2	V2001	Screen	1
3	J4009	Short Rubber Strap w/ S-Hook	2
4	K1030	1/4"-20 x 1-1/4" Carriage Bolt	2
5	K0037	Flat Washer / 1/4" (.75 OD x .312 ID x .060 T)	2
6	K1128	1/4"-20 Nyloc Nut	2
7	K0062	Fender Washer / .230 ID x 1.500 OD / Zinc	2
8	K0114	Black Plastic Rivet	11
9	C0067	Dust Guard Mnt. Brkt.	1
10	V1117	Dust Guard	1
11	R0022	Decal / Built In The USA / Lg	1
12	R1069	Decal / Warning - Turn Off Blower	1
13	R1054	Decal / Important Check Hoses	1
14	R1051	Decal / Warning - Use Hearing Protection	1
15	R1057	Decal / 2" x 4" Red Reflector	2
16	C0026	Grass Deflector	1
17	B0676	Hinge Stop Pl.	1

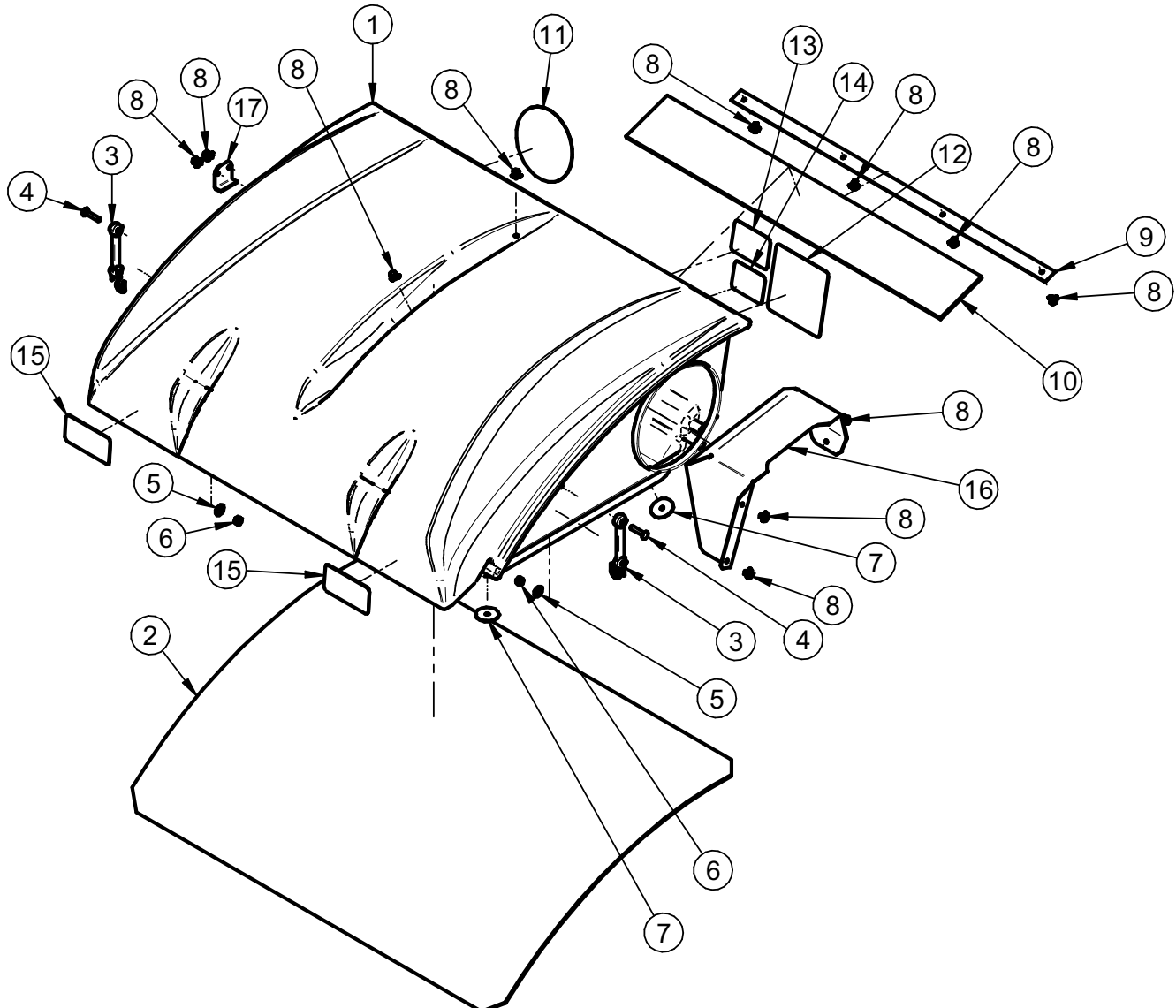

Unit Model #: 28120902

Mower & Type: Kubota Z400 Commander Pro Series

Mower Models: Z411KW-48

Mower Deck Size: 48" Deck

Owner's Manual: Q0525

Revision #: 1 - Update PTO-X - XY 1/2/2019

Vac/Drive Type: P2B+ (9 Cu. Ft.) PTO-X Driven

Fits Year(s): 2016 & Newer



A2168 Vac Kit

- (1) HB0683 Vac Kit Hardware Bag
- (1) A2101 Top Assy. w/ PECO Logo
- (1) A2111 Inlet w/ Snap Fastener / 6"
- (1) F0060-023 6" x 23" Upper Hose
- (1) A2047 Upper Frame Assy.
- (2) B0227 Bag Ring
- (2) G0013 4 Cu. Ft. Collection Bags w/out Labels
- (1) J0060 Hose Clamp
- (2) B0640 Lwr. Mnt. Tubes (29")

A2125 Mount Kit

- (1) F0080-036 8" x 36" Lower Hose
- (2) J0080 Hose Clamps
- (1) HB0692 Wiring Harness Hardware Bag
- (1) HB0691 Mount Kit Hardware Bag
- (1) M0313 AK79 Aramax Belt
- (1) HB0693 Engine Pulley Hardware Bag
- (1) A2069_02 Belt Guard Assy.
- (1) B0992 Rear Mount Plate
- (1) E6009 8" Blower Cone
- (1) A2061_02 Drive Assy. w/ 4-Blade Impeller

A2167 Boot Kit

- (1) E0036A Boot
- (1) A2118 Deck Plate
- (1) HB0688 Hardware Bag
- (1) B1064 Discharge Guard
- (1) A1121 Boot Plate
- (1) B0244 Boot Rod

A2121 Dual Weight Kit / Single Caster

- (1) B1015 Weight Bracket Clamp
- (2) Y0025 28 lb. Weight
- (1) HB0687 HW Bag
- (1) B1014 Dual Weight Bracket Base

A2121 Dual Weight Kit / Single Caster

- (1) B1015 Weight Bracket Clamp
- (2) Y0025 28 lb. Weight
- (1) HB0687 HW Bag
- (1) B1014 Dual Weight Bracket Base

SAFETY DECALS

To promote safe operation, New PECO, Inc. supplies safety decals on all products manufactured. Damage can occur to safety decals either through shipment, use or reconditioning. Contact your local Service Center for replacement decals.



Part# R1070
PECO Logo



Part# R0022
Designed & Built
In The USA



Part #: R2007
Danger - Never Use Hands



Part #: R2008
Danger - Rotating Blades

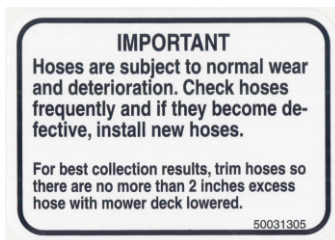

Part #: R1054
Important - Hose Wear

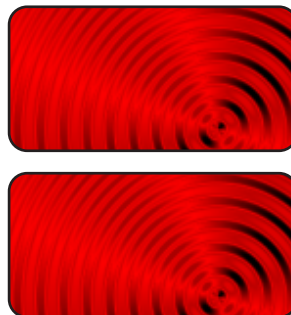

Part #: R1057 - (2)
Red Reflectors



Part #: R1069
Warning - Turn Off Blower



Part # R0024
Danger - Keep Hands
Clear



Part #: R1051
Warning - Hearing Protection



Part # R0025
Danger - Rotating
Blades

SECTION III OPERATING INSTRUCTIONS

General Safety

Only qualified people familiar with this operator's manual and the mower's operator's manual should operate this machine.

Operation And Tips On Mowing

- A. Perform BEFORE EACH USE the maintenance list referenced in Section IV.
- B. Start mower.
- C. With the mower at high idle speed, engage the mower deck.
- D. While seated in the operator's seat, move Bagger PTO switch to the on position. With the PTO assembly engaged, you can proceed to operate the control levers of the mower.

NOTE: If the collection system does not appear to be collecting the grass clippings, disengage the deck and PTO assembly, then, engage the parking brake and turn the mower off. Check upper and lower hoses for any clogs.

To obtain the maximum effectiveness from your collection system, the tips listed below should be followed:

- * Watch your speed- Normal conditions will allow a speed of up to approximately 4 mph, but thick, heavy damp conditions will require reduced ground speed.
- * Mow with sharp blades- A sharp blade cuts cleaner.
- * Wet grass and leaves will decrease effectiveness and will increase horsepower requirements.
- * Mow at higher cutting heights- Remove and mulch no more than 2" of grass length with each mowing. (Experts recommend not cutting off more than 1/3 of the grass blade length at any given time.)
- * Mow twice, at different height settings, (high, then low), if grass is extra tall.
- * Remember that horsepower requirements will vary with the mowing conditions such as type and height of turf grass, moisture content, amount of leaves, whether the terrain is flat or hilly, etc.

Disengagement Of The PTO Assembly

- A. To disengage the PTO assembly, move Bagger PTO switch to the off position.

WARNING: The PTO assembly blades will continue to spin. DO NOT TOUCH the PTO assembly, pulleys, or the belt until the tractor is turned off. DO NOT adjust the belt tension until the mower is turned off. Refer to the Belt Installation section of the manual.

Unloading The Collection System

- A. Stop the forward movement of the mower, engage the parking brake.
- B. Disengage the mower deck.
- C. Disengage the blower.
- D. Verify that the dump area is clear.
- E. Push the dump handle, on the left of the operator, away from the unit. While holding the handle pushed away, move the handle upward. The container door will swing upward and the container will rotate downward. The container will release its contents.
- F. Once the contents of the container have fallen out, the container is ready to move back into its normal operating position. Pull the handle downward until positive latching is achieved.

NOTE: Do not allow collection system to become over-filled as potential damage may occur to your equipment. Also, be sure to clean the screen as needed.

SECTION IV MAINTENANCE

Maintenance Checklist

Before each use:

1. Check blades and spindles to be sure that no foreign objects, such as wire or steel strapping bands, are wrapped around them.
2. Inspect blades for wear. Replace if necessary. If it is necessary to sharpen the blades, remove the blades from the spindles before sharpening. DO NOT sharpen blades while still attached to the mower.

3. Make sure all shields are in place and in good condition. Repair or replace any missing or damaged shields.
4. Perform lubrication per instructions.
5. Listen for abnormal sounds, which might indicate loose parts, damaged bearings, or other damage. Correct any deficiency before continuing operation.
6. With the engine off, engage the blower assembly. Check the belt tension and inspect the pulley belt for cracks or tears.
7. Check for wear or deterioration of the upper or lower hoses. If there are any portions of the hose that have been torn or worn through, replace immediately.

After Each Use:

1. Clean all debris from machine especially from the container, underneath the belt shields, and safety decals. Replace any missing or illegible decals.
2. Inspect the unit for worn or damaged components. Repair or replace before the next use. Any replacement component installed during repair shall include the component's current safety decal specified by the manufacturers to be affixed to the component.
3. Under normal usage, the bag material is subject to deterioration and wear and should therefore be frequently checked for necessary replacement. Any replacement bag should be checked to ensure compliance with the original manufacturer's recommendations or specifications.
4. Check belt for proper tension.

4-2 Lubrication

Gearbox:

NOTE: The gearbox is filled with 6.0 oz. of Mobilube HD Plus 80W-90 oil and permanently sealed. There is no need for scheduled lubrication. The oil level should only be checked if a leak is observed or if a change in gearbox noise is noticed.

Operators are recommended to check for leaks weekly. If a leak is observed, both the gasket and the seals are recommended to be replaced.

Replace the oil using 5.5 oz. of the recommended Mobilube HD Plus 80W-90 oil. Be sure to not overfill.

Blower Assembly:

NOTE: The following is for older PTO models that contain a greaseable zirc fitting. Newer models contain maintenance-free bearings and are without a greasable fitting.

1. On initial use: Grease the fitting on the blower shaft.
2. Every 25 hours of use: Re-grease the grease fitting.

NOTE: Use only white lithium based grease for lubrication of the shaft on the blower assembly.

SECTION V - PARTS & SERVICE

5-1 Parts And Service Information

Collection system owners should record the name and telephone number of their Service Center. Your Service Center will be happy to supply replacement parts, accessories, and do any service or repairs to your collection system. If for any reason your Service Center is unable to service your collection system or supply replacement parts, contact New PECO, Inc. and include the following information on the chart below.

DOCUMENT THE FOLLOWING INFORMATION FOR FUTURE REFERENCE

Unit Model Number: _____

Unit Engine Size: _____

Unit Serial Number: _____

Date of purchase: ____ / ____ / ____

Dealer/Distributor Name: _____

Address: _____ **State:** _____ **Zip:** _____

Phone Number: _____

New PECO, Inc.

10 Walden Dr | Arden, North Carolina 28704

Phone: 1-800-438-5823 | 828-684-1234

Fax: 828-684-0858

Email: peco@lawnvac.com

Website: www.lawnvac.com

TORQUE SPECIFICATIONS

Proper torque for American fasteners used on PECO equipment.
Recommended Torque in Foot Pounds (Newton Meters).*

AMERICAN Bolt Head Markings

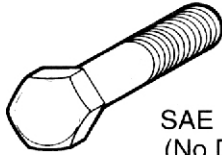

SAE Grade 2
(No Dashes)

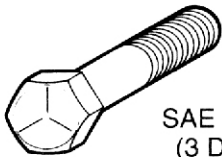

SAE Grade 5
(3 Dashes)

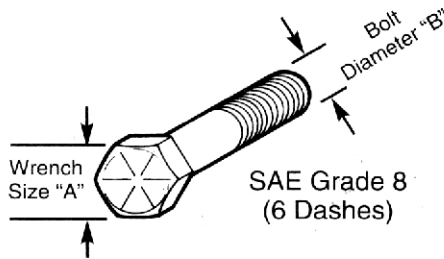

SAE Grade 8
(6 Dashes)

WRENCH SIZE (IN.) "A"	BOLT DIAMETER (IN.) "B" AND THREAD SIZE	SAE GRADE 2	SAE GRADE 5	SAE GRADE 8
7/16	1/4 - 20 UNC	6 (7)	8 (11)	12 (16)
7/16	1/4 - 28 UNF	6 (8)	10 (13)	14 (18)
1/2	5/16 - 18 UNC	11 (15)	17 (23)	25 (33)
1/2	5/16 - 24 UNF	13 (17)	19 (26)	27 (37)
9/16	3/8 - 16 UNC	20 (27)	31 (42)	44 (60)
9/16	3/8 - 24 UNF	23 (31)	35 (47)	49 (66)
5/8	7/16 - 14 UNC	32 (43)	49 (66)	70 (95)
5/8	7/16 - 20 UNF	36 (49)	55 (75)	78 (106)
3/4	1/2 - 13 UNC	49 (66)	76 (103)	106 (144)
3/4	1/2 - 20 UNF	55 (75)	85 (115)	120 (163)
7/8	9/16 - 12 UNC	70 (95)	109 (148)	153 (207)
7/8	9/16 - 18 UNF	79 (107)	122 (165)	172 (233)
15/16	5/8 - 11 UNC	97 (131)	150 (203)	212 (287)
15/16	5/8 - 18 UNF	110 (149)	170 (230)	240 (325)
1-1/8	3/4 - 10 UNC	144 (195)	266 (360)	376 (509)
1-1/8	3/4 - 16 UNF	192 (260)	297 (402)	420 (569)
1-5/16	7/8 - 9 UNC	166 (225)	430 (583)	606 (821)
1-5/16	7/8 - 14 UNF	184 (249)	474 (642)	668 (905)
1-1/2	1 - 8 UNC	250 (339)	644 (873)	909 (1232)
1-1/2	1 - 12 UNF	274 (371)	705 (955)	995 (1348)
1-1/2	1 - 14 UNF	280 (379)	721 (977)	1019 (1381)
1-11/16	1-1/8 - 7 UNC	354 (480)	795 (1077)	1288(1745)
1-11/16	1-1/8 - 12 UNF	397 (538)	890 (1206)	1444 (1957)
1-7/8	1-1/4 - 7 UNC	500 (678)	1120 (1518)	1817 (2462)
1-7/8	1-1/4 - 12 UNF	553 (749)	1241 (1682)	2013 (2728)
2-1/16	1-3/8 - 6 UNC	655 (887)	1470 (1992)	2382 (3228)
2-1/16	1-3/8 - 12 UNF	746 (1011)	1672 (2266)	2712 (3675)
2-1/4	1-1/2 - 6 UNC	870 (1179)	1950 (2642)	3161 (4283)
2-1/4	1-1/2 - 12 UNF	979 (1327)	2194 (2973)	3557 (4820)

METRIC

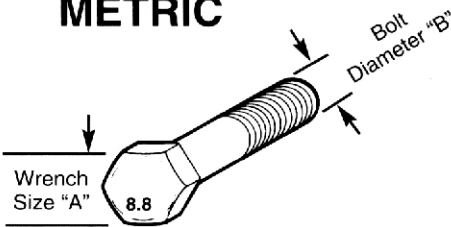

Numbers appearing on bolt heads indicate ASTM class.

Proper torque for metric fasteners used on PECO equipment.
Recommended torque in foot pounds (newton Meters).*

WRENCH SIZE (mm) "A"	BOLT DIA. (mm) "B"	ASTM 4.6	ASTM 8.8	ASTM 9.8	ASTM 10.9
8	5	1.8 (2.4)		5.1 (6.9)	6.5 (8.8)
10	6	3 (4)		8.7 (12)	11.1 (15)
13	8	7.3 (10)		21.1 (29)	27 (37)
16	10	14.5 (20)		42 (57)	53 (72)
18	12	25 (34)	74 (100)	73 (99)	93 (126)
21	14	40 (54)	118 (160)	116 (157)	148 (201)
24	16	62 (84)	167 (226)	181 (245)	230 (312)
30	20	122 (165)	325 (440)		449 (608)
33	22		443 (600)		611 (828)
36	24	211 (286)	563 (763)		778 (1054)
41	27		821 (1112)		1138 (1542)
46	30	418 (566)	1119 (1516)		1547 (2096)

*Use 75% of the specified torque value for plated fasteners. Use 85% of the specified torque values for lubricated fasteners.

Troubleshooting

2017 (v1.0)

Collection System Performance

Problem	Possible Cause	Corrective Action
Abnormal Vibration	<ul style="list-style-type: none"> • Cutting blades are bent or unbalanced • Loose blower pulley or pulley assembly • Impeller blade out of balance 	<ul style="list-style-type: none"> • Install new cutting blade • Tighten the pulley • Contact dealer to replace
Reduced collection system performance	<ul style="list-style-type: none"> • Low engine speed • Plugged screen • Loose belt • Full collection bags 	<ul style="list-style-type: none"> • Always operate collection system at full throttle • Remove debris, leaves, or grass clippings from the screen • Replace/tighten belt • Empty the collection bags
Blower and hoses plugging too frequently	<ul style="list-style-type: none"> • Collection bags are too full • Low engine speed • Grass is too wet • Grass is too long • Ground speed is too fast • Worn belt • Loose belt 	<ul style="list-style-type: none"> • Dump more frequently • Always operate collection system at full throttle • Cut grass when it is dry • Cut the grass several times • Drive slower at full throttle • Replace belt • Adjust the pulley and tighten belts
Debris blowout	<ul style="list-style-type: none"> • Collection bags are too full • Plug/clog in the collection system • Ground speed is too fast 	<ul style="list-style-type: none"> • Dump more frequently • Clean the collection system • Drive more slowly at full throttle
Impeller doesn't rotate freely	<ul style="list-style-type: none"> • Plug in the blower housing • Worn impeller blade • Shaft bearings bad/failing 	<ul style="list-style-type: none"> • Clean the blower housing • Contact dealer to replace • Contact dealer to replace

Notes



New PECO, Inc.
10 Walden Dr | Arden, North Carolina 28704
Phone: 1-800-438-5823 | 828-684-1234
Fax: 828-684-0858
Email: peco@lawnvac.com
Website: www.lawnvac.com