



# GRASS COLLECTION SYSTEM

## OPERATOR'S MANUAL



**Designed For:**  
**Z900 Series**  
**2013 & Newer**



### **Briggs & Stratton 6.5HP Vanguard Engine Driven Models:**

06131510 (54" Deck) - (Z915B, Z920M, Z920R, Z925M EFI, Z930R)

06131513 (60" Deck) - (Z915B, Z920M, Z925M EFI, Z930M,  
Z930M EFI, Z930R, Z950R, Z960R)

### **Briggs & Stratton 900 Series Engine Driven Models:**

06131511 (54" Deck) - (Z915B, Z920M, Z920R, Z925M EFI, Z930R)

06131514 (60" Deck) - (Z915B, Z920M, Z925M EFI, Z930M,  
Z930M EFI, Z930R, Z950R, Z960R)

### **PTO Models:**

06131512 - Z915B 54" (CV740 Kohler)

06131515 - Z915B 60" (CV740 Kohler)

06131516 - Z930R 54" (FX801V Kawasaki)

06131517 - Z930M/Z930R 60" (FX801V Kawasaki)

**ASSEMBLY • OPERATION • MAINTENANCE**

# GRASS COLLECTION SYSTEM

## TABLE OF CONTENTS

SECTION	PAGE	SECTION	PAGE
Safety	2	2-18 Boot To Mower Deck Installation	15
Safety Alert Symbols	3	2-19 Length Of Hose Adjustment	16
Warranty	4	2-20 Upper Hose Installation	16
I INTRODUCTION AND DESCRIPTION	5	2-21 Lower Hose To Blower Cone Installation	16
1-1 Introduction	5	2-22 Lower Hose To Boot Installation	16
1-2 Description	5	2-23 Impeller Blade Removal And Replacement	17
II INSTALLATION FOR USE	6	2-24 Weight Kit Installation	18
2-1 Preparation Of Mower	6	2-25 Throttle Cable Kit Installation	19
2-2 Frame Bracket Installation	7	2-26 Installation And Removal Of Collection Bags	20
2-3 Exhaust Diverter Installation	8	Exploded Views and Parts List	21-34
2-4 PTO Mount Plate Component Installation	9	III OPERATING INSTRUCTIONS	35
2-5 PTO Assembly Installation	10	3-1 General Safety	35
2-6 PTO Handle Installation	10	3-2 Operation & Tips On Mowing	35
2-7 Belt Installation And Adjustment	11	3-3 Disengagement Of The Blower	35
2-8 Cam Assembly Adjustment	12	3-4 Unloading The Collection System	35
2-9 Outer Engine Mount Tube Installation	12	IV MAINTENANCE	35
2-10 Engine Mount Arm Assembly Installation	12	4-1 Maintenance Checklist	35-36
2-11 Engine/Blower/Blade Assembly Installation	12	4-2 Lubrication	36
2-12 Lower Mount Tube Installation	13	V PARTS AND SERVICE	36
2-13 Upper Frame Assembly Installation	13	5-1 Parts And Service Information	36
2-14 Top Assembly To Upper Frame Assembly Installation	14	Safety Decals	37
2-15 Hinge Kit Installation	14	Torque Specifications	38
2-16 Inlet installation	14		
2-17 Blower Cone Installation	15		

## SAFETY

1. Read the operator's manual carefully and familiarize yourself with the proper use of your attachment. Do not allow anyone who is not acquainted with the Safety Instructions to use your attachment.
2. Know the controls and how to stop them quickly. **READ THE OPERATOR'S MANUAL!**
3. Do not allow children to operate the machine. Do not allow adults to operate it without proper instruction.
4. Be especially watchful of children and pets entering into the area while operating.
5. Keep your eyes and mind on your machine while mowing or operating your attachment. Don't let others distract you.
6. Do not attempt to operate your machine when not in the driver's seat.
7. Always shut off blades and engine when emptying the container.
8. Stop machine, shut off deck attachment, set parking brake, shut off engine and remove ignition key before removing clogs, removing or replacing hose, boot, blower cone, or performing any maintenance.
9. Mow across the face of slopes (not more than 10 degrees); never up and down the face.
10. It is recommended that the container be emptied when half full while operating on slopes. Start mowing on slopes when the container is empty.
11. Inspect your lawn and remove any foreign objects before mowing. Never deliberately run the mower across any foreign object.
12. Wear hearing protection.
13. Wear eye protection to prevent debris from getting into your eyes.

# SAFETY

**WARNING!** NEVER operate the mower unless the discharge guard and either the deflector assembly or the vacuum collector adapter are fastened securely in place.

**WARNING!** Do not work around the mower deck boot or the blower area until you are certain that the mower blades and the blower impeller have stopped rotating.

**WARNING!** To avoid serious injury, perform maintenance on the vacuum collector; **ONLY AFTER STOPPING THE MOWER'S ENGINE AND WAITING FOR ALL MOVING PARTS TO COME TO A COMPLETE STOP.** Set the parking brake. Always remove the ignition key before beginning maintenance.

**WARNING!** For your own personal safety, **ALWAYS mow ACROSS the face of slopes and NEVER UP and DOWN the face. NEVER attempt to mow excessively steep slopes, and use caution when turning on any slope.**

## Safety Alert Symbol



This Safety Alert Symbol means: **“ATTENTION! BECOME ALERT! YOUR SAFETY IS INVOLVED!”**

This symbol is used to call attention to safety precautions that should be followed by the operator to avoid accidents. When you see this symbol, carefully read the message that follows and heed its advice. Failure to comply with safety precautions could result in death or serious bodily injury.

## Safety Signs

The signal words **DANGER**, **WARNING**, and **CAUTION** are used on the equipment safety signs. These words are intended to alert the viewer to the existence and the degree of hazard seriousness.



White letters on **RED**

This signal word indicates a potentially hazardous situation which, if not avoided, will result in death or serious injury.



Black letters on **ORANGE**

This signal word indicates a potentially hazardous situation which, if not avoided, could result in death or serious injury.

It may also be used to alert against unsafe practices.



Black letters on **YELLOW**

This signal word indicates a potentially hazardous situation which, if not avoided, will result in minor or moderate injury.

It may also be used to alert against unsafe practices.

# PECO LIMITED WARRANTY FOR NEW PRODUCTS

## A. WHAT IS UNDER WARRANTY?

PECO extends the following warranties to the original purchaser of each new PECO consumer product subject to the following limitations.

- 1. PRODUCT WARRANTY:** Any part of any consumer product, which is defective in material or workmanship as delivered to the purchaser will be repaired or replaced, as PECO elects, without charge for parts or labor, if the defect appears within 12 months from the date of delivery of the product to the original purchaser. ALL DEFECTIVE PARTS MUST BE RETURNED TO PECO FOR INSPECTION TO DETERMINE VALIDITY OF WARRANTY CLAIMS. Freight and mailing will be borne by the customer.
- 2. PARTS REPLACED DURING WARRANTY:** Any new PECO part which is furnished in performance of this warranty and is defective in material or workmanship as delivered to the purchaser will be repaired or replaced, before the expiration of the original warranty period, whichever is later.
- 3. COMMERCIAL USE:** Products put to personal use around a single household or residence is considered 'Residential'; Products put to any business use (agricultural, commercial, or industrial) or used at multiple locations is considered 'Commercial.' Products designated as 'Commercial' are warrantied for 12 months from the date of delivery of the product to the original purchaser when used for in commercial applications. Products designated as 'Residential' are warrantied for 90 days from the date of delivery of the product to the original purchaser when in commercial applications.

## B. SECURING WARRANTY ADJUSTMENTS

Call PECO for Return Authorization. Damaged or broken parts other than engines or batteries, must be returned to New PECO, Inc. at 10 Walden Drive, Arden, NC 28704 before any warranty adjustment can be authorized. At the time of requesting warranty adjustment, the purchaser must present evidence of the date of delivery of the product. The purchaser shall pay any charge for the product to and from Arden, NC.

## C. ITEMS NOT COVERED BY PECO WARRANTY

Engines and batteries attached to PECO products are covered under a separate warranty by the respective manufacturer.

## D. UNAPPROVED ALTERATION OR MODIFICATION

All obligations of New PECO, Inc. under this warranty shall be terminated if products are altered or modified in ways not approved by New PECO, Inc.

## E. ACCIDENTS AND NORMAL MAINTENANCE

The warranty covers only defective material and workmanship. It does not cover depreciation or damage caused by normal wear, accident, improper use or abuse of products. The cost of normal maintenance and normal replacement of service items such as belts, cutting blades, hoses, etc., which are not defective shall be paid for by the purchaser.

## F. NO REPRESENTATIONS ADDITIONAL WARRANTIES, DISCLAIMER

Neither New PECO, Inc. nor any company affiliated with it makes any warranties, representations or promises as to the quality of performance of its products other than those set forth herein. Except as described above, New PECO, Inc. makes no other warranties AND SPECIFICALLY DISCLAIMS ANY AND ALL IMPLIED WARRANTIES OF FITNESS AND MERCHANTABILITY.

## G. PRODUCTS USED FOR RENTAL OR LEASE PURPOSES ARE WARRANTIED FOR 45 DAYS FROM DATE OF ORIGINAL SALE ONLY

## H. REMEDIED EXCLUSIVE

The only remedies the purchaser has in connection with the breach or performance of any warranty on New PECO, Inc. consumer products are set forth above. In no event will PECO be liable for special incidental or consequential damages.

### 1. NO SERVICE CENTER WARRANTY

The selling Service Center makes no warranty on his own on any item warrantied by New PECO, Inc. unless he delivers to purchaser a separate written warranty certificate specifically warranting the item. The dealer has no authority to make any representation or promise on behalf of PECO or to modify the terms of this warranty in any way.



# Section I - INTRODUCTION AND DESCRIPTION

## 1-1 Introduction

We are pleased to have you as a PECO customer. Your collection system has been designed to give you a low maintenance, simple, and effective way to collect the grass clippings from your mower. This manual is provided to give you the necessary instructions to properly mount and operate the collection system on your mower. Please read this manual thoroughly. Understand what each control is for and how to use it. Observe all safety decal precautions on the machine and noted throughout the manual.

**NOTE:** all references made to right, left, front, rear, top or bottom are as viewed from the normal operator's position on the mower.

## 1-2 Description

The grass collection system is designed for turf maintenance where there is a need to collect the grass clippings as the mower cuts the turf. It is also used for picking up leaves and in pre-season and post-season clean-up. The blower, mounted on the right side of the unit, uses a belt and gearbox system from the engine PTO shaft. Drive train protection comes through belt slippage. The blower is also available with an external engine option of Briggs & Stratton 900 Series or 6.5HP Vanguard. The blower draws grass clippings from the discharge area of the cutter deck back to the (3) - 4.0 cubic foot collection bags P#(G0003) at the rear portion of the mower frame. The operator can engage the blower with a push of the over-center linkage on the right side of the unit. Once the bags are full with clippings, they can be released to make for easy dumping.

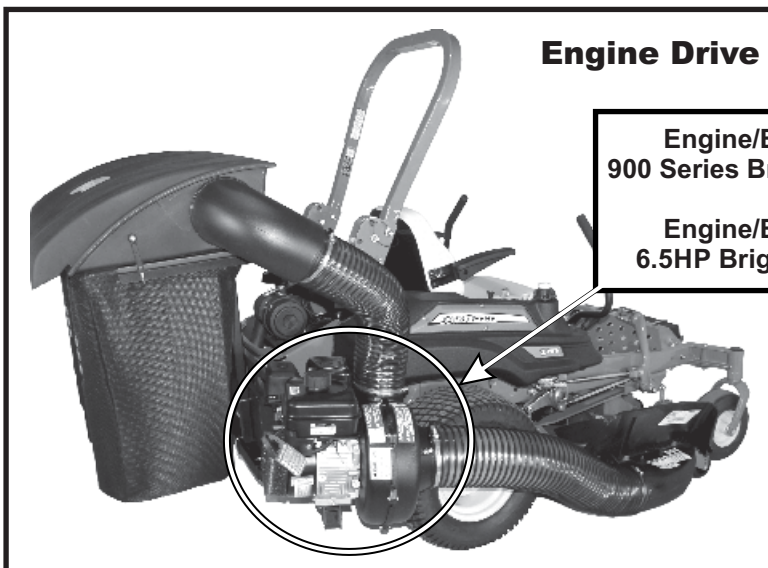
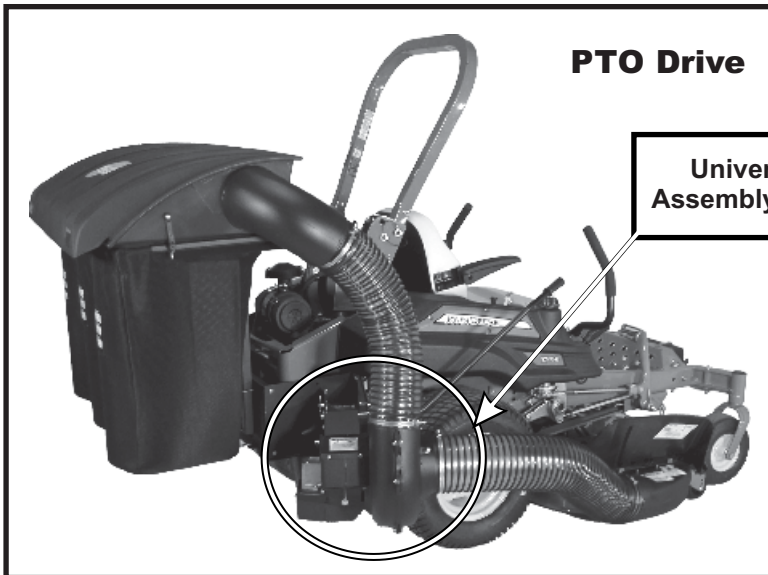

## Section II - INSTALLATION FOR USE

### 2-1 Preparation Of Mower

#### PTO Drive Models Only

From the underside of the engine, disconnect the wiring harness attached to the electric clutch. Remove the bolt and electric clutch from the mower. Next remove the D-drive spacer using an arbor press or equivalent. On removal, adjacent bearing OUTER race must be supported or bearing damage may occur. Refer to Figure 2-1a.

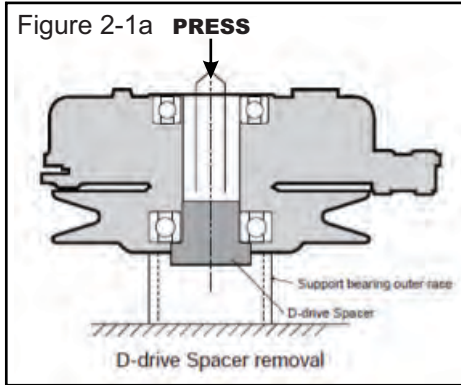

The engine pulley bushing must be installed using an arbor press or equivalent. During installation, opposite bearing inner race must be supported or bearing damage may occur. Refer to Figure 2-1c.

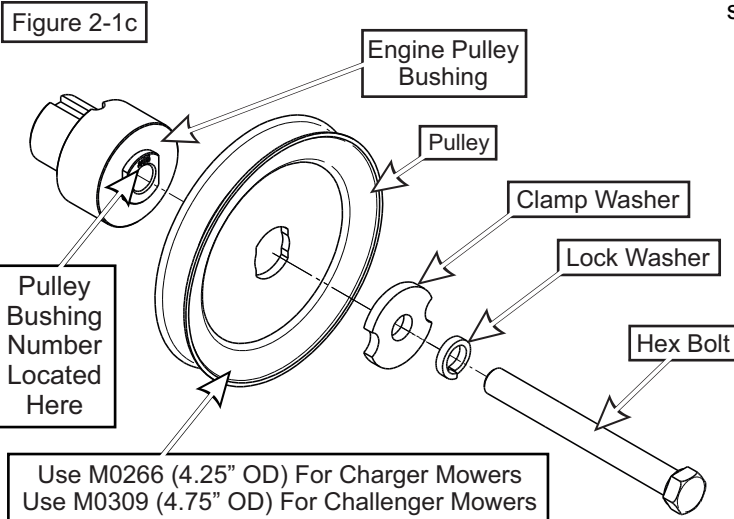
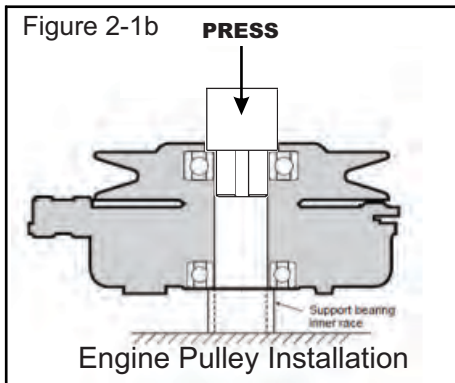

Upon pressing the engine pulley to the clutch, replace the completed assembly to the mower's engine shaft to fasten.

#### Kohler Cv740

Fasten engine pulley bushing number 18 P#(S0210) to the electric clutch using (1) Clamp Washer P#(K0278), (1) 7/16" lock washer P#(K0140), and 7/16"-20 x 4" hex bolt P#(K0359). Torque the bolt to 55 ft./lbs. The added pulley will power the collection system and should resemble Figure 2-1d when installed.

#### Kawasaki FX801V

Fasten engine pulley bushing number 30 P#(S0219) to the electric clutch using (1) Clamp Washer P#(K0278), (1) 7/16" lock washer P#(K0140), and 7/16"-20 x 4" hex bolt P#(K0359). Torque the bolt to 55 ft./lbs. The added pulley will power the collection system and should resemble Figure 2-1d when installed.

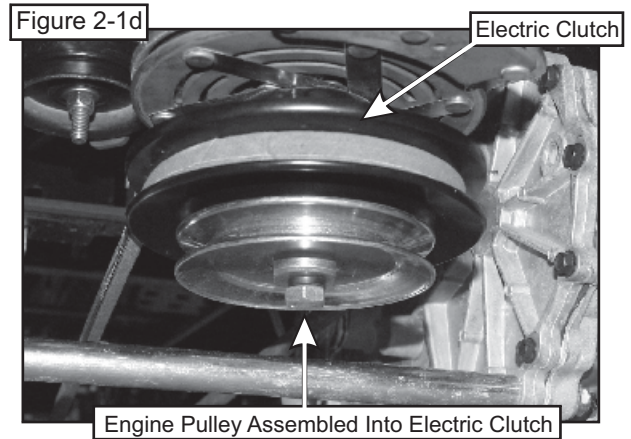

Your collection system framework will mount directly to the rear frame of the Z900 series mower. First, loosen and remove the metric hex bolts securing the mower's engine shroud (2 per side). Once the shroud is removed, use a flat-head screwdriver to remove the retaining nuts from the shroud. Next, replace and align the holes in the shroud to the mower's bumper. Then, remove the larger metric hex bolt from the mower's bumper (1 per side). Place the removed bolts aside to be used in the next step. Refer to Figure 2-1e.

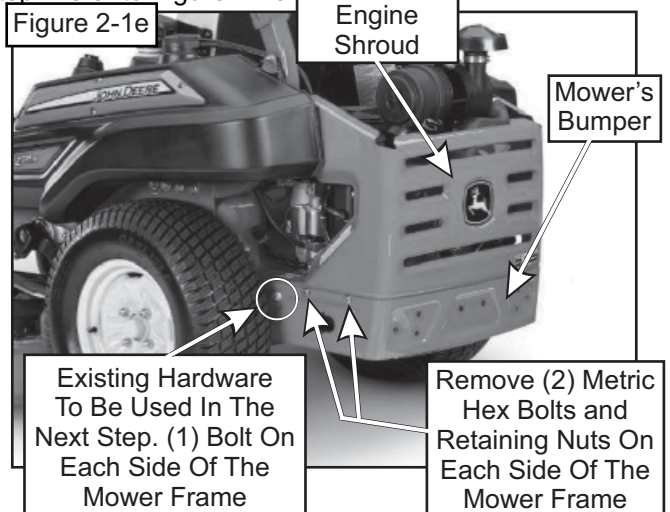

## 2-2 Frame Bracket Installation

Secure the right frame bracket P#(B0866) to the rear frame of the mower, using (1) existing metric hex bolt, (2) 5/16"-18 x 1" HHCS P#(K1154) and (2) 5/16"-18 nylon flange locknuts P#(K2516). Refer to Figure 2-2.

Secure the rear frame bracket P#(B0867) to the left and right frame bracket, using (4) 3/8"-16 x 1" HHCS P#(K1191) and (4) 3/8"-16 nylon flange locknuts P#(K2038). Refer to Figure 2-2.

Secure the left frame bracket P#(B0865) to the rear frame of the mower, using (1) existing metric hex bolt, (2) 5/16"-18 x 1" HHCS P#(K1154) and (2) 5/16"-18 nylon flange locknuts P#(K2516). Refer to Figure 2-2.

**Note:** For PTO driven models, refrain from securing the (2) 5/16"-18 x 1" HHCS on the right frame bracket, until performing Section 2-4.

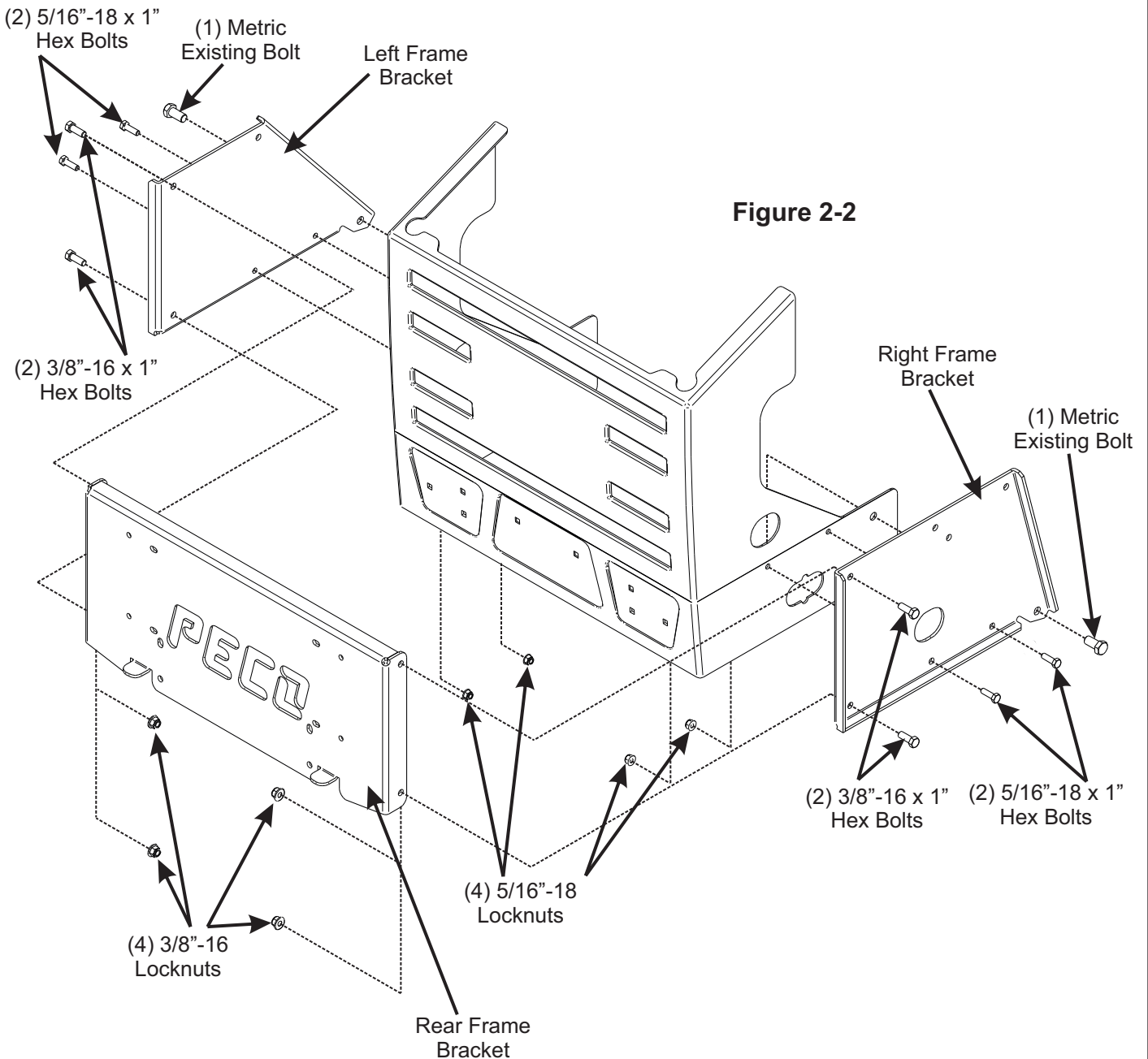

Figure 2-2

## 2-3 Exhaust Diverter Installation

An exhaust diverter will need to be installed on your mower to prevent the exhaust from damaging the PTO assembly or Engine/Blower/Blade Assembly.

### Kohler CV740 Engines

Attach (1) diverter P#(J0290) to the engine exhaust pipe.

### Kawasaki FX801V Engines

Attach (1) exhaust diverter P#(J0293) and (1) clamp kit P#(X1025) to the engine exhaust pipe.

Position the diverter so that the exhaust blows to the rear, and so that it does not burn the collection bags or the ground. Refer to Figure 2-3.

Figure 2-3

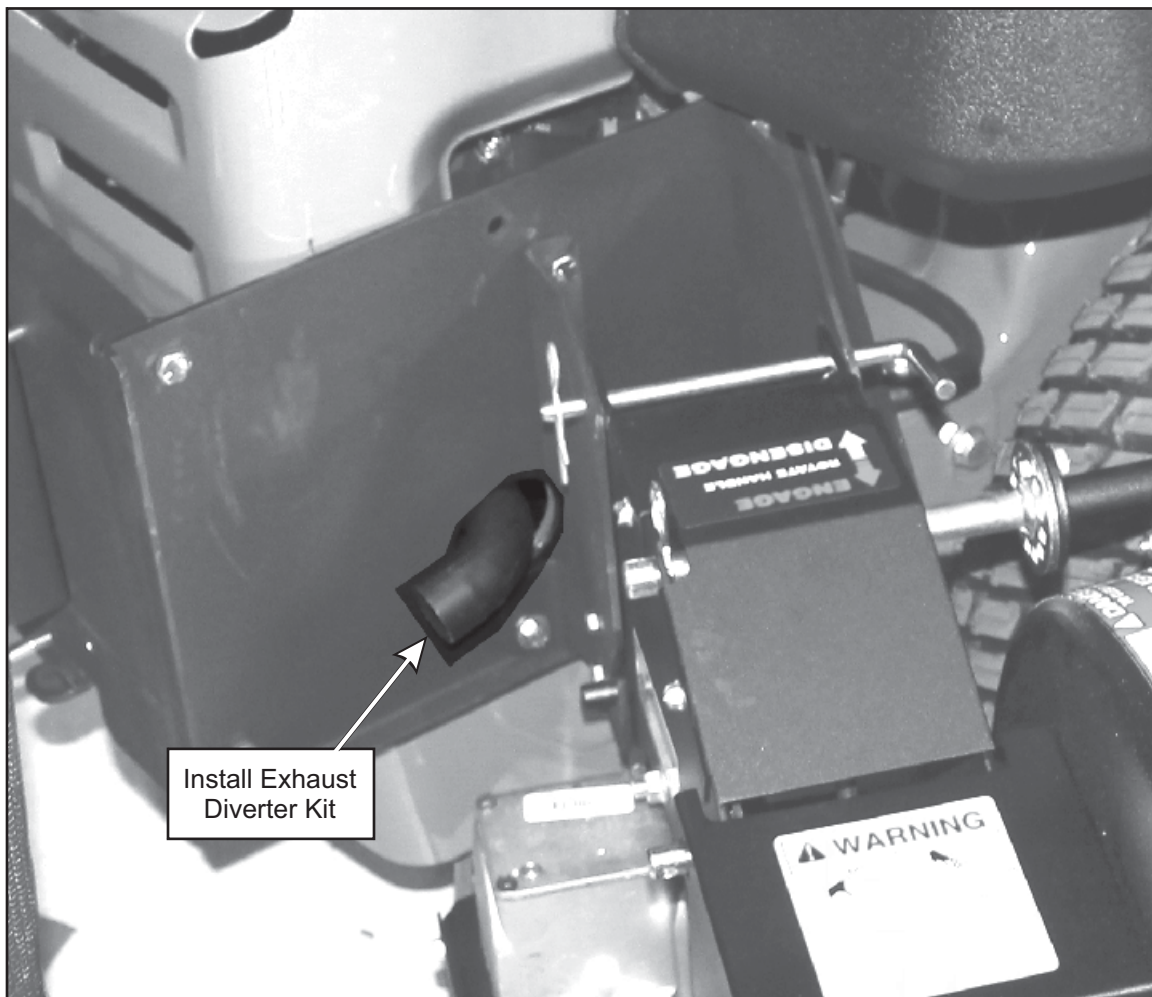



## 2-4 PTO Mount Plate Component Installation

### PTO Drive Models Only

Secure the PTO stop plate P#(B0736) to the left PTO mount plate P#(B0868) and right PTO mount plate P#(B0869) using (4) 1/4"-20 x 3/4" HHCS P#(K1222) and (4) 1/4"-20 nylon flange locknuts P#(K2014). Leave the hardware finger tight until all of the PTO mount plate components are installed. Refer to Figure 2-4a.

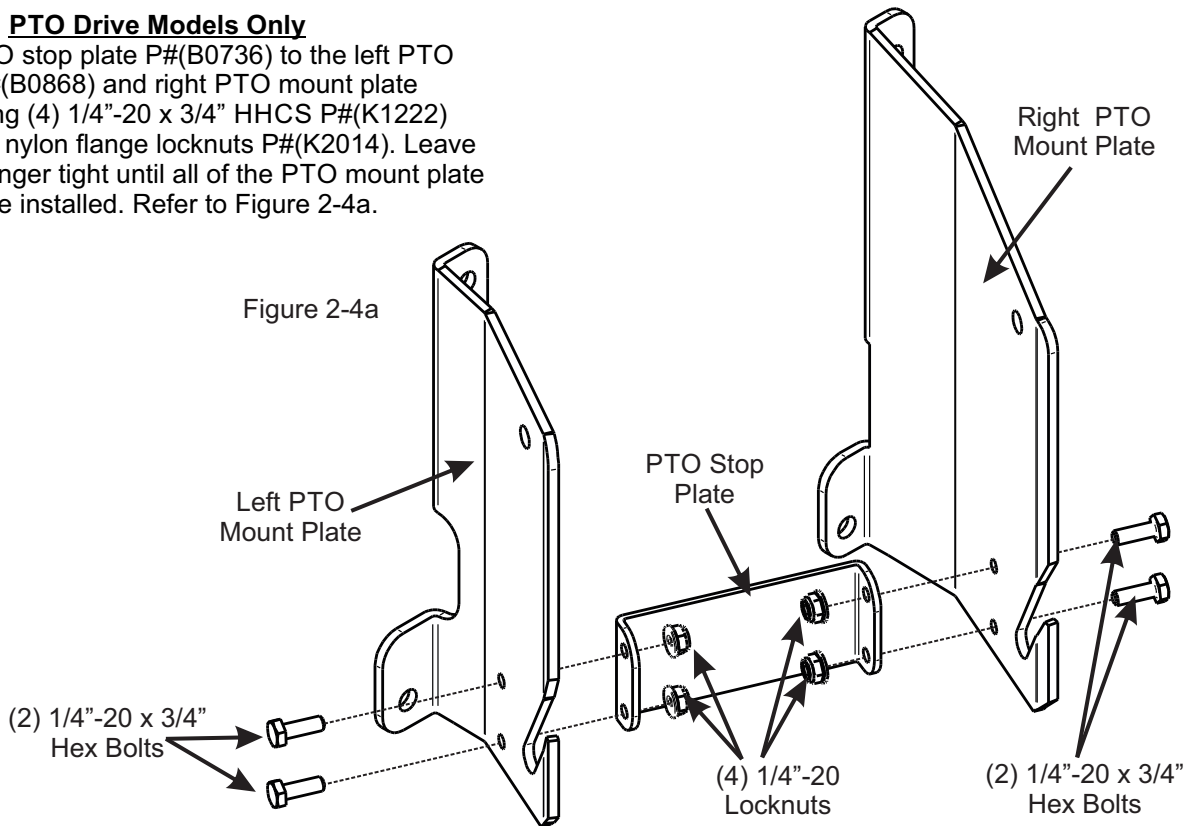

Secure the left and right PTO mount plates to the right frame bracket using (1) 3/8"-16 x 1" HHCS P#(K1191) and (1) 3/8"-16 nylon flange lock nut PER BRACKET. Secure the bottom sections of the left and right PTO mount brackets using (2) 5/16"-18 x 1" HHCS P#(K1154) and (2) 5/16"-18 nylon flange locknuts P#(K2516) from the right frame bracket installation. Tighten all PTO component hardware at this time. Refer to Figure 2-4b.

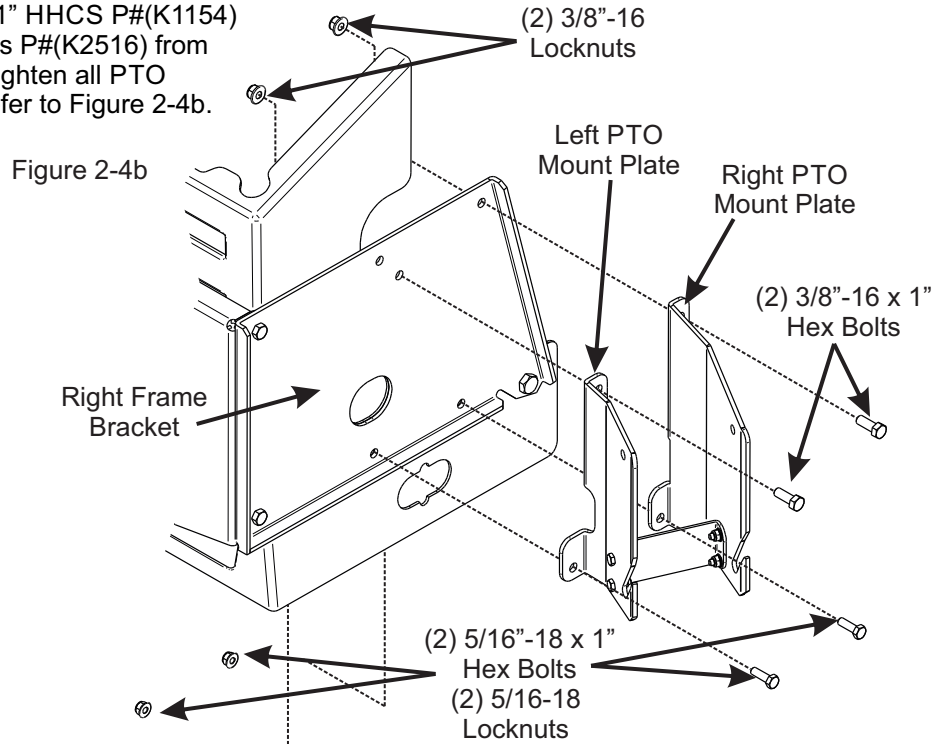

## 2-5 PTO Assembly Installation

### PTO Drive Models Only

Lift the PTO Assembly P#(A1950) into position as shown in Figure 2-5a, inserting the PTO pivot pin into the slots on the left and right PTO mount plates.

Sure the PTO assembly to the left and right PTO mount plate using (1) PTO mount pin P#(B0274) and (1) hair pin clip P#(K0086). Refer to Figure 2-5b.

Figure 2-5a

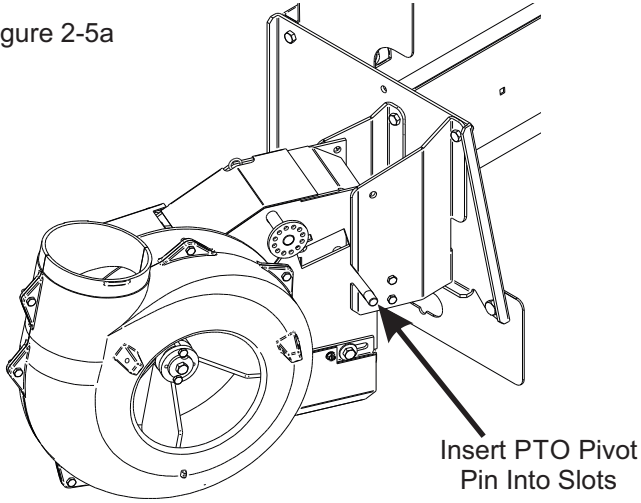

**Note:** Remove the gearbox pulley guard in preparation for the belt installation. Refer to Figure 2-5c.

Figure 2-5c

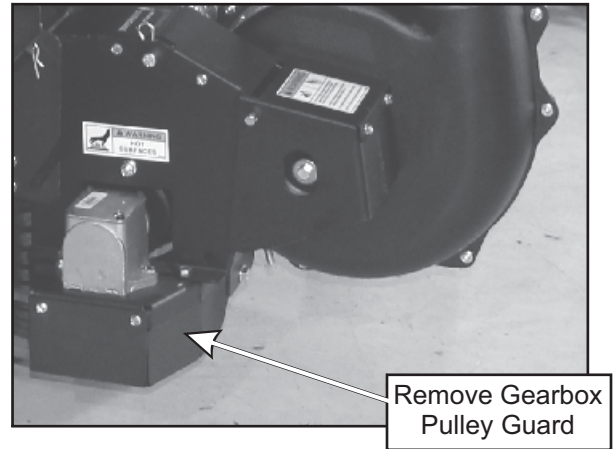

## 2-6 PTO Handle Installation

Attach the PTO handle P#(A1142) to the PTO assembly using (3) 1/4"-20 x 3/4" HHCS P#(K1222) and (3) 1/4"-20 nylon flange locknuts P#(K2014). Attach the handle grip P#(J0522) to the PTO handle. Refer to Figure 2-6b.

**NOTE:** The PTO Handle can be adjusted after performing Step 2-8 to achieve proper belt adjustment. To adjust the handle, remove (3) 1/4"-20 x 3/4" HHCS P#(K1222) and (3) 1/4"-20 nylon flange locknuts P#(K2014), rotate handle until positioned in the desired location (while aligning holes) and reattach. The bolts should be kept approximately 120 degrees apart to ensure proper fastening.

Figure 2-5b

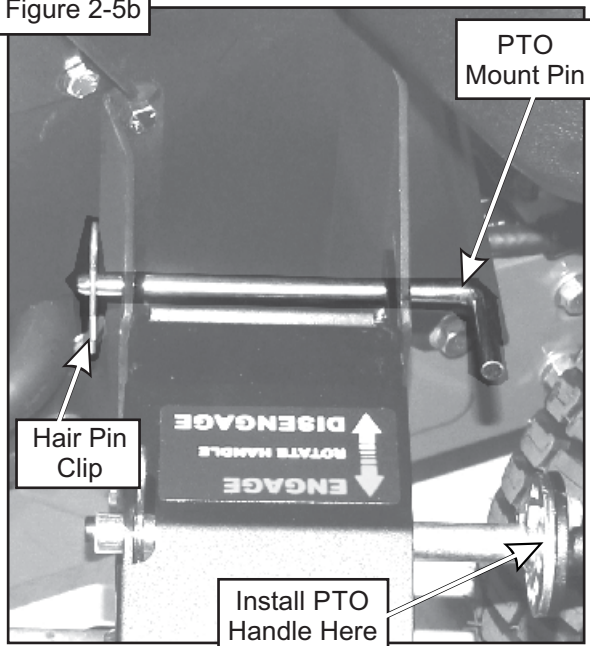
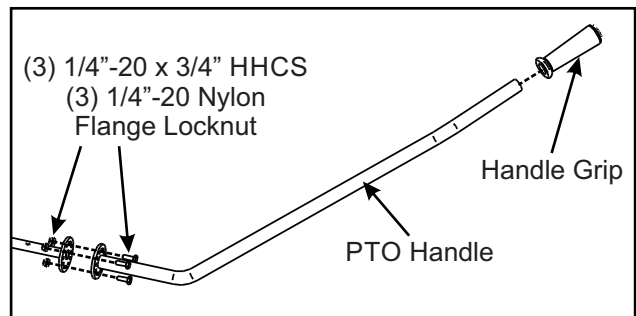

Figure 2-6



## 2-7 Belt Installation and Adjustment PTO MODELS ONLY

Loosen the (4) bolts P#(K1191), (2) on each side, that secure the gear box assembly to the PTO assembly P#(A1950) (Figure 2-7a and 2-7b).

Figure 2-7a

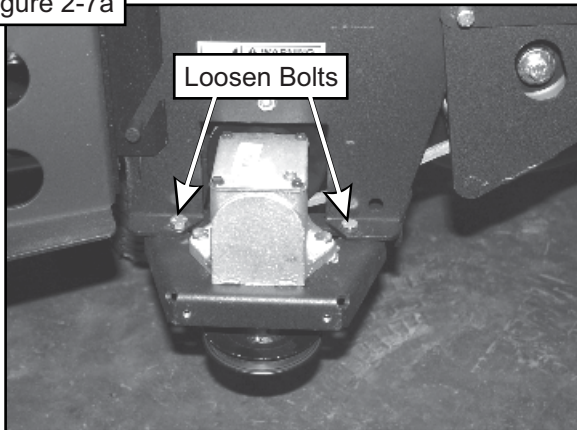
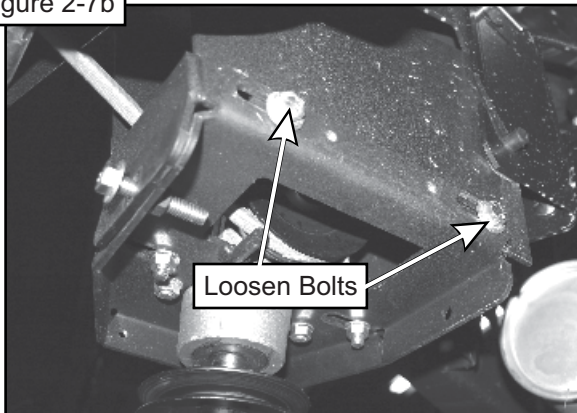
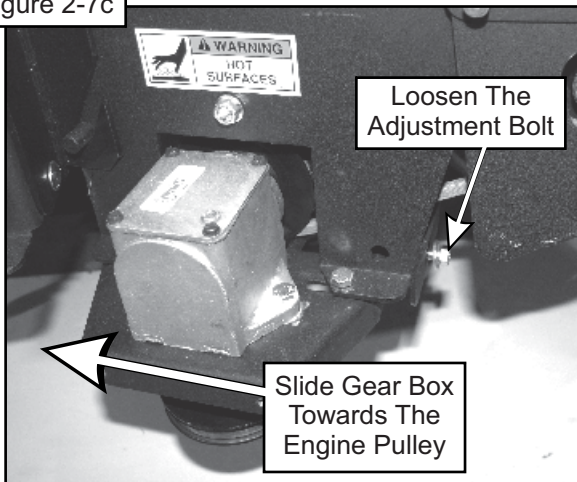

Figure 2-7b



Loosen the adjustment bolt P#(K0348) until the gear box assembly is at its far left adjustment (the gear box is moved toward the mower's engine pulley). Refer to Figure 2-7c.

Figure 2-7c



Connect the belt A56K P#(M0239) from the engine pulley to the lower gear box pulley (Figure 2-7d).

Figure 2-7d

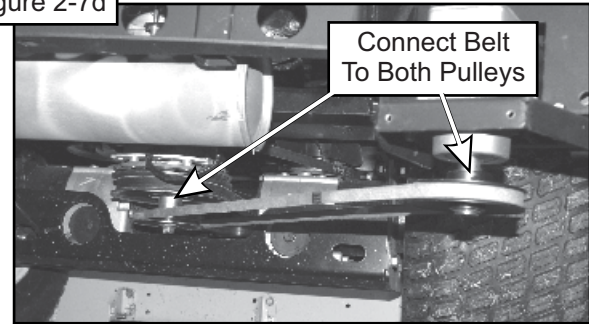

To tension the drive belt, turn the adjustment bolt clockwise (Figure 2-7e) until there is 1" of deflection, with 10-11 lbs. of pressure, at the center of the belt between the engine pulley and the gear box pulley.

Figure 2-7e

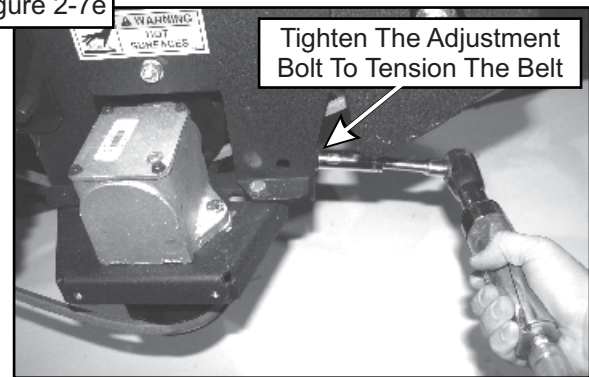

Once the correct tension of the belt is achieved, tighten the (4) bolts that secure the gear box assembly. Refer to Figures 2-7f and 2-7g. Replace the belt guard and hardware that was removed in Section 2-5.

Figure 2-7f

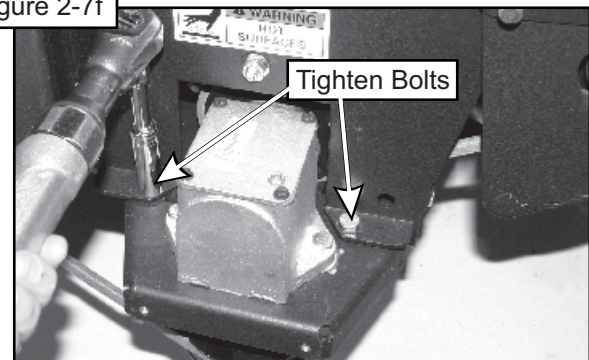
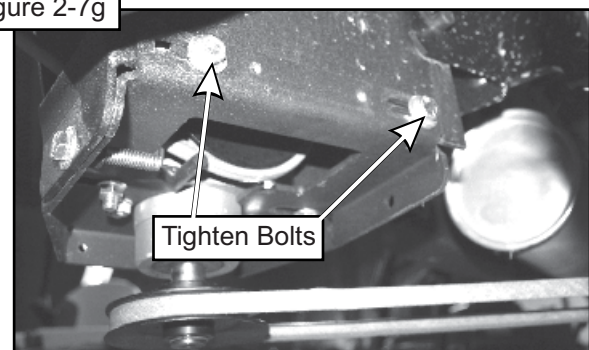

Figure 2-7g





## 2-8 Cam Assembly Adjustment PTO MODELS ONLY

The cam assembly P#(A0422), which controls the blower belt tension, comes from the factory pre-adjusted. If the belt is too tight or becomes too loose, remove the hair pin clip P#(K0099) from the belt tension rod P#(K0326) and pull the "L" end of the rod out of its hole in the cam assembly. The tension rod may then be screwed out to tighten the belt or screwed in to loosen the belt. Replace the "L" end into the top hole in the cam and replace the hair pin clip. Adjust the cam stop bolt P#(K1159) to allow the cam to rotate slightly over center when the blower is disengaged (Figure 2-8).

Figure 2-8

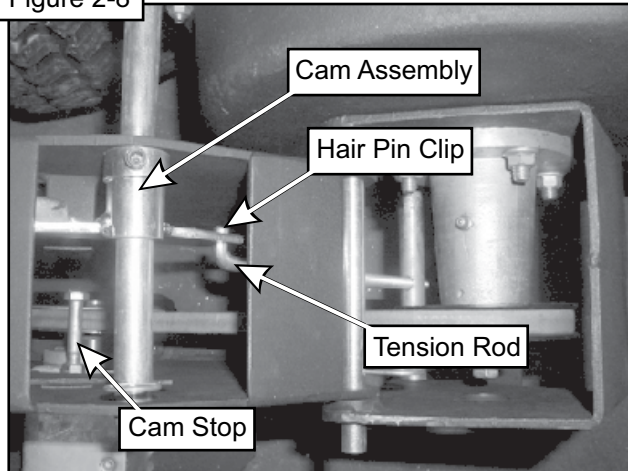

## 2-9 Outer Engine Mount Tube Installation

### Engine Drive Models Only

Position the outer engine mount tube P#(B1117) as shown in Figure 2-9. Secure the outer engine mount tube to the rear frame bracket using (2) 3/8"-16 x 2-1/8" u-bolt P#(K1119) and (4) 3/8"-16 nylon flange lock nuts P#(K2038). Orient the tube so that the detent pin mount hole is to the right side of the mower. Leave hardware finger tight until the engine/blower/blade assembly has been installed.

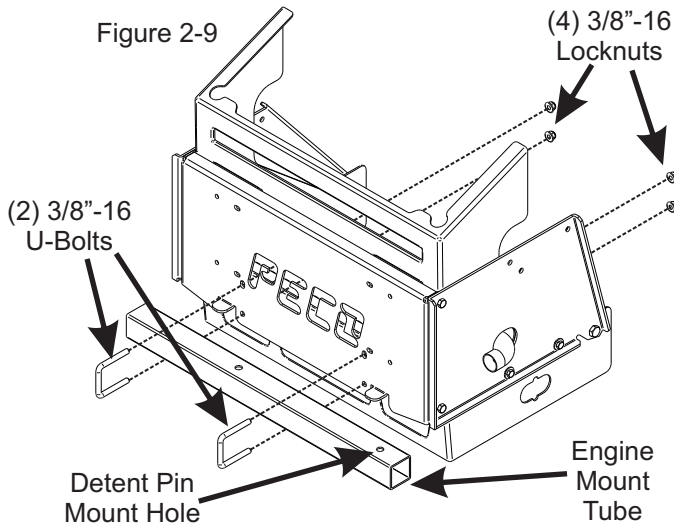

## 2-10 Engine Mount Arm Assembly Installation

### Engine Drive Models Only

Insert the engine mount arm assembly P#(A0274) into the outer engine mount tube and secure using (1) detent pin P#(J0248). Refer to Figure 2-10.

Figure 2-10

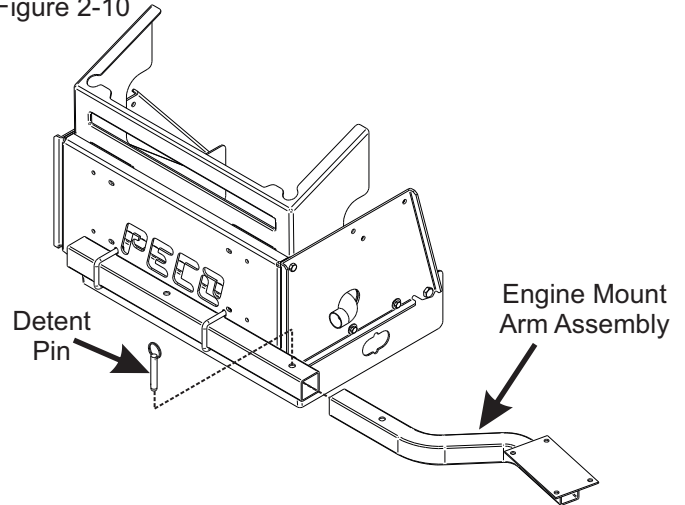

## 2-11 Engine/Blower/Blade Assembly Installation

### Engine Drive Models Only

Place the engine blower blade assembly on top of the engine mount arm as shown in Figure 2-11. Secure the assembly using (4) 5/16"-18 x 1-1/2" HHCS P#(K1157) and (4) 5/16"-18 nylon flange lock nuts P#(K2516). Reposition the engine mount arm and outer engine mount tube so that there is between 1/2" to 1" of clearance between the blower housing and the rear tire. When the blower assembly has the proper clearance, tighten the hardware from Section 2-9 and 2-10.

Figure 2-11

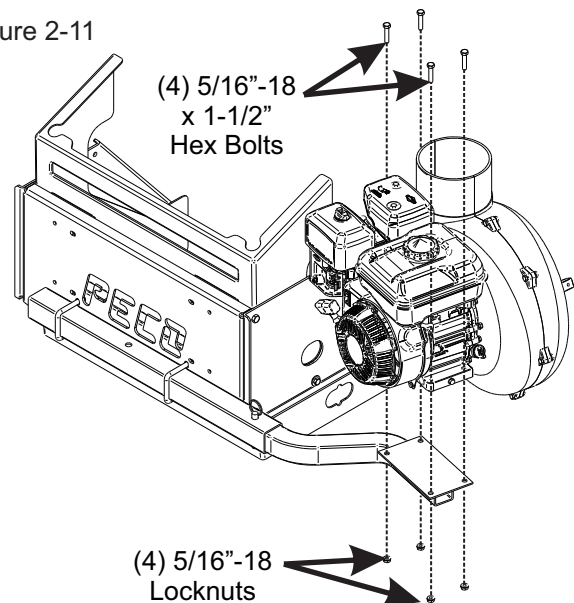



## 2-12 Lower Mount Tube Installation

Secure the (2) lower mount tubes P#(B0640) to the rear frame bracket using (2) 5/16"-18 u-bolts P#(K1098) and (4) 5/16"-18 nylon flange locknuts P#(K2516) PER TUBE. Refer to Figure 2-13.

## 2-13 Upper Frame Assembly Installation

Position the upper frame assembly P#(A1058) above the lower mount tubes as shown in Figure 2-13. Slide the upper frame assembly down onto the lower frame tubes and secure using (2) clevis pins P#(K0133) and (2) hair pin clips P#(K0088).

Figure 2-13

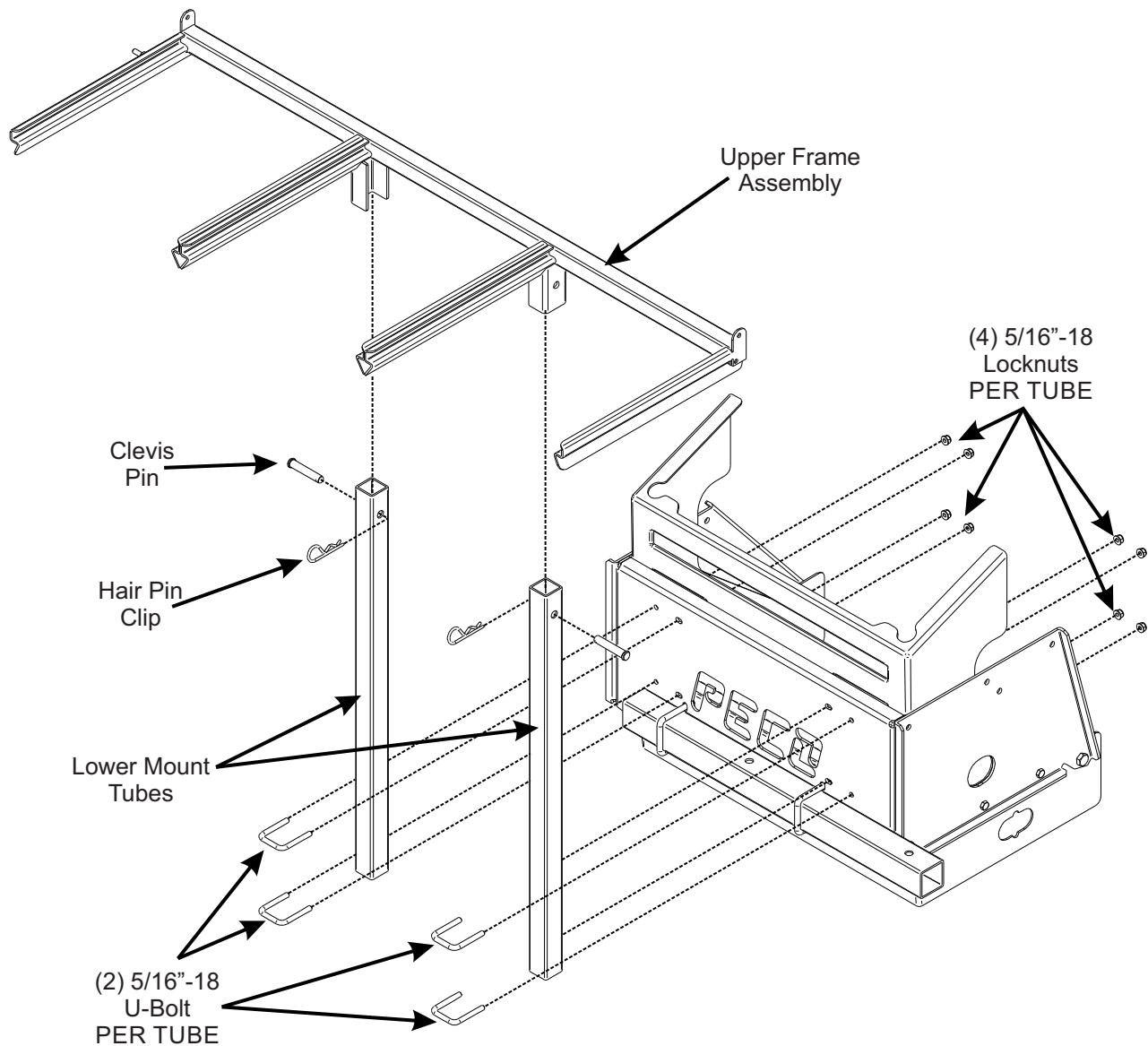

## 2-14 Top Assembly To Upper Frame

### Assembly Installation

Position the top assembly P#(A1158) above the upper frame assembly as shown in Figure 2-14. Fasten the top assembly to the upper frame assembly using (2) 5/16"-18 x 2-1/2" HHCS P#(K0125) and (2) 5/16"-18 nylon flange locknuts P#(K2516). Leave the locknuts slightly loose, to allow the top assembly to open and close easily. Refer to Figure 2-14 for hardware location.

## 2-16 Inlet Installation

Slide the inlet P#(V0025) into the hole on the bagger top until the inlet locks into place. The inlet should pivot 360 degrees about the hole in the bagger top. Refer to Figure 2-14.

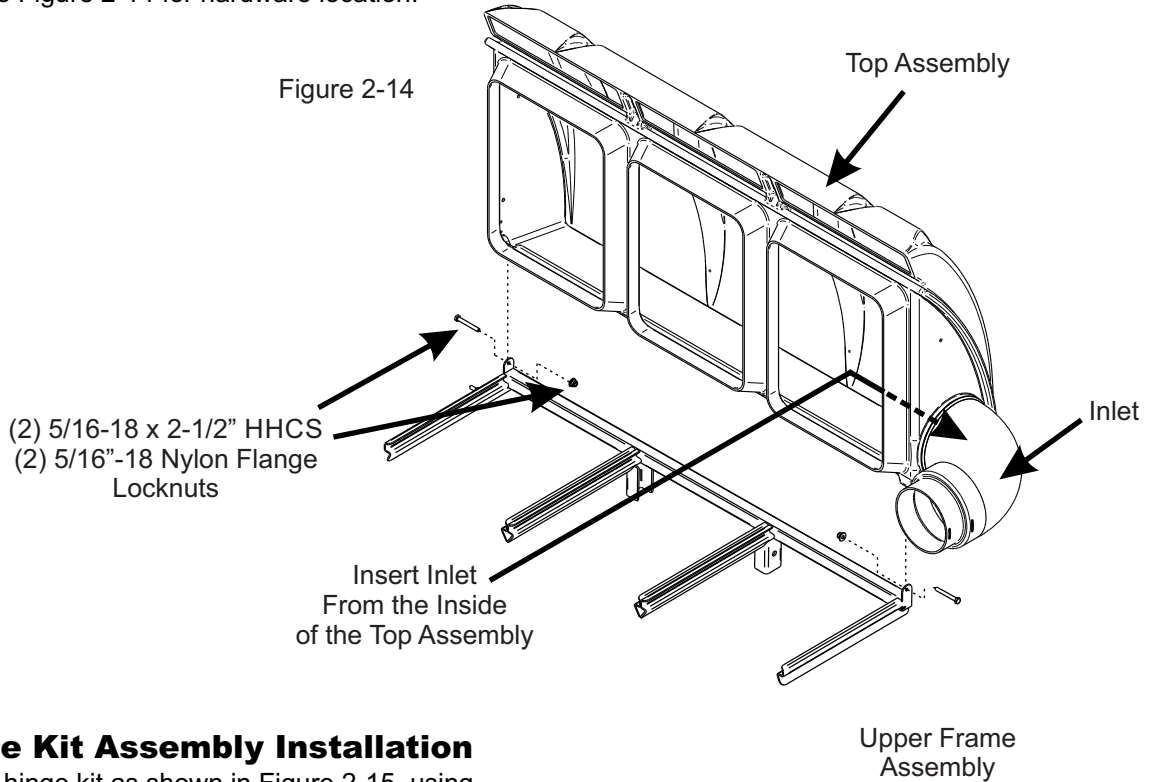

## 2-15 Hinge Kit Assembly Installation

Assemble the hinge kit as shown in Figure 2-15, using (2) 5/16"-18 x 1" HHCS P#(K1154), (3) 5/16"-18 nylon flange locknuts P#(K2516), (5) 1/4" flat washers P#(K0037) and (2) swing arm brackets P#(ZT-0004). Place (1) vinyl cap P#(J0289) on the end of the hex bolts as shown in Figure 2-15. Leave the nuts loose enough to allow fluid movement of the top when opening and closing. When opened, the top should rest on the middle joint of the hinge allowing it to remain up.

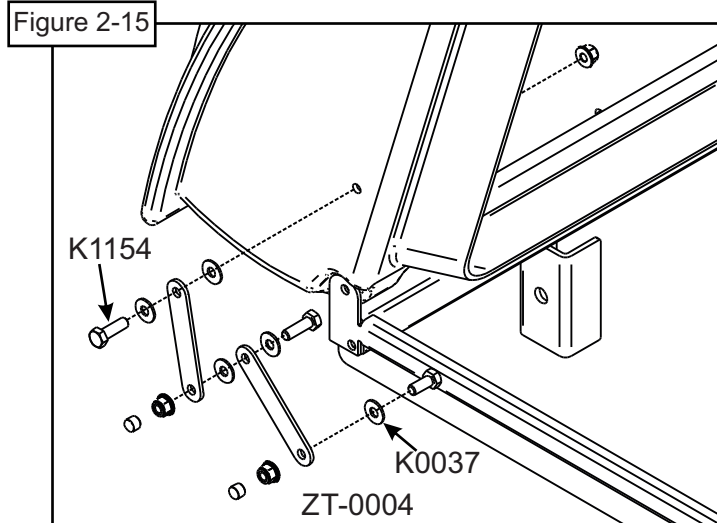

## 2-17 Blower Cone Installation

Thread (1) 5/16"-18 jam nut P#(K0120) onto each end of (2) 5/16"-18 x 2-1/2" HHCS P#(K0125) as shown in Figure 2-17a.

Figure 2-17a

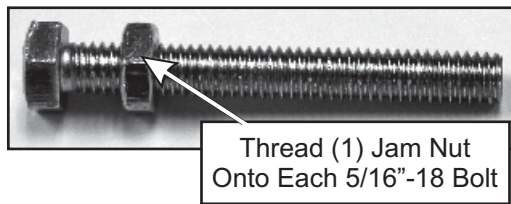

Now partially thread (1) bolt into each of the two threaded bosses located on the blower housing. Place blower cone so the two tabs line up with the bolts and tighten completely as shown in Figure 2-17b.

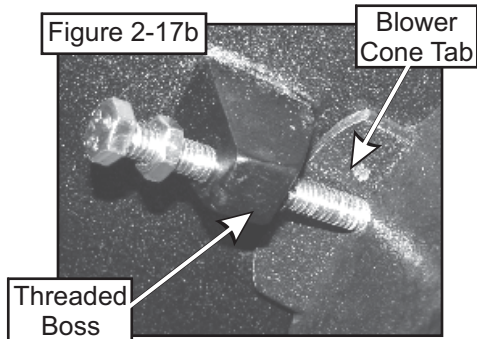

Once the (2) bolts are tight, tighten the jam nuts against the threaded boss as shown in Figure 2-17c.

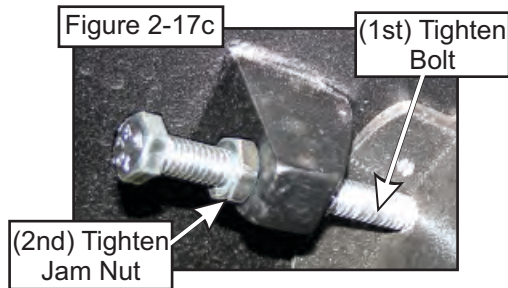

Refer to Figure 2-17d for proper blower cone installation reference.

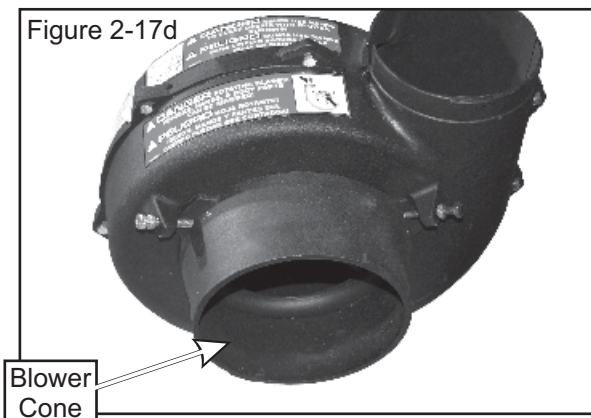

## 2-18 Boot To Mower Deck Installation

### 54" Deck

Secure the boot plate P#(B0001) to the aluminum boot P#(E1103) using (2) 3/8"-16 x 1" carriage bolts P#(K1182) and (2) 3/8"-16 nylon flange locknuts P#(K2038). Insert the bolts from the inside so that the threads are on top of the boot. This will prevent grass clippings from collecting on the bolt threads. Leave the hardware loose until the boot assembly has been attached to the mower deck. Lift the grass deflector and slide the boot plate under the grass deflector rod. Close any gaps between the boot and the mower deck by adjusting the position on the boot in the boot plate slots. Tighten all hardware at this time. Refer to Figure 2-18a.

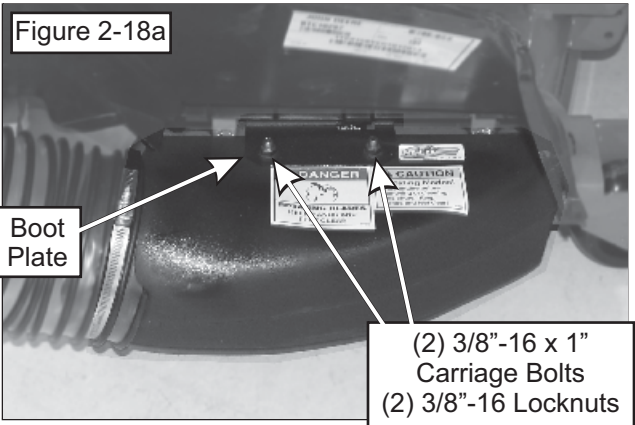

### 60" Deck

Secure the boot plate P#(B1815) to the aluminum boot P#(E1126) using (2) 3/8"-16 x 1" carriage bolts P#(K1182) and (2) 3/8"-16 nylon flange locknuts P#(K2038). Insert the bolts from the inside so that the threads are on top of the boot. This will prevent grass clippings from collecting on the bolt threads. Leave the hardware loose until the boot assembly has been attached to the mower deck. Lift the grass deflector and slide the boot plate under the grass deflector rod. Close any gaps between the boot and the mower deck by adjusting the position on the boot in the boot plate slots. Tighten all hardware at this time. Refer to Figure 2-18b.

Figure 2-18b

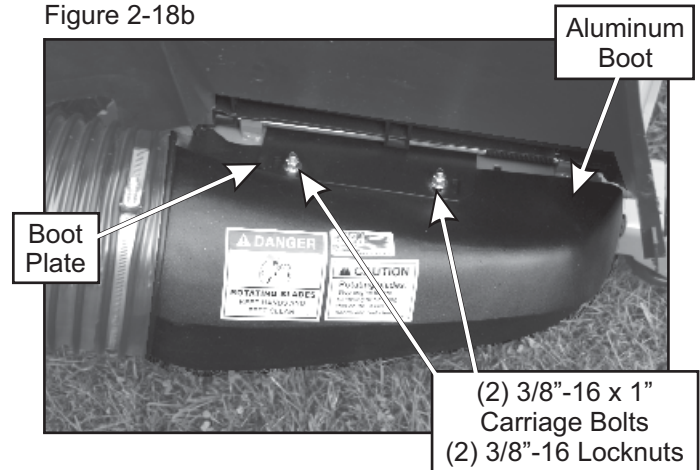

## 2-19 Length Of Hose Adjustment

The hoses in steps 2-20 and 2-21 must be cut to fit your machine. Follow steps 2-20 and 2-21. Do not cut the hoses until you have tried to fit them on your machine. Remember that the hoses need to be long enough to allow for the opening and closing of the collection system, PTO blower housing engagement, as well as allowing ample clamping surface between each component.

## 2-20 Upper Hose Installation

Slide a 6" hose clamp P#(J0060) onto both ends of the 6" upper hose (Figure 2-22). Slide one end of the 6" hose onto the plastic inlet P#(V0025). Make sure there is about a two-inch overlap between the hose end and the plastic inlet. Proceed to slide the opposite end of the 6" hose onto the outlet of the blower assembly. See (Figure 2-22) for details. Make sure both ends of the hose are clearly attached to the inlet and the blower assembly inlet. Tighten the hose clamps.

## 2-21 Lower Hose To Blower Cone Installation

Slide a hose clamp P#(J0070 or J0090) over both ends of the lower hose. Then proceed to slide the lower hose onto the blower cone. Tighten the hose clamp. The assembly should look like Figure 2-22.

## 2-22 Lower Hose To Boot Installation

Take the unattached end of the lower hose and slide it over the circular end of the boot. Use the lower hose clamp to secure the hose to the boot (Figure 2-22). Tip: Before securing clamp rotate hose counter-clockwise (away from yourself) approximately 1" to aid in retaining boot to mower deck.

**Note:** For maximum collection system performance, adjust the hose lengths (Step 2-19) to achieve the smoothest transition between components. Avoid any sharp bends in the upper and lower hoses.

Figure 2-22

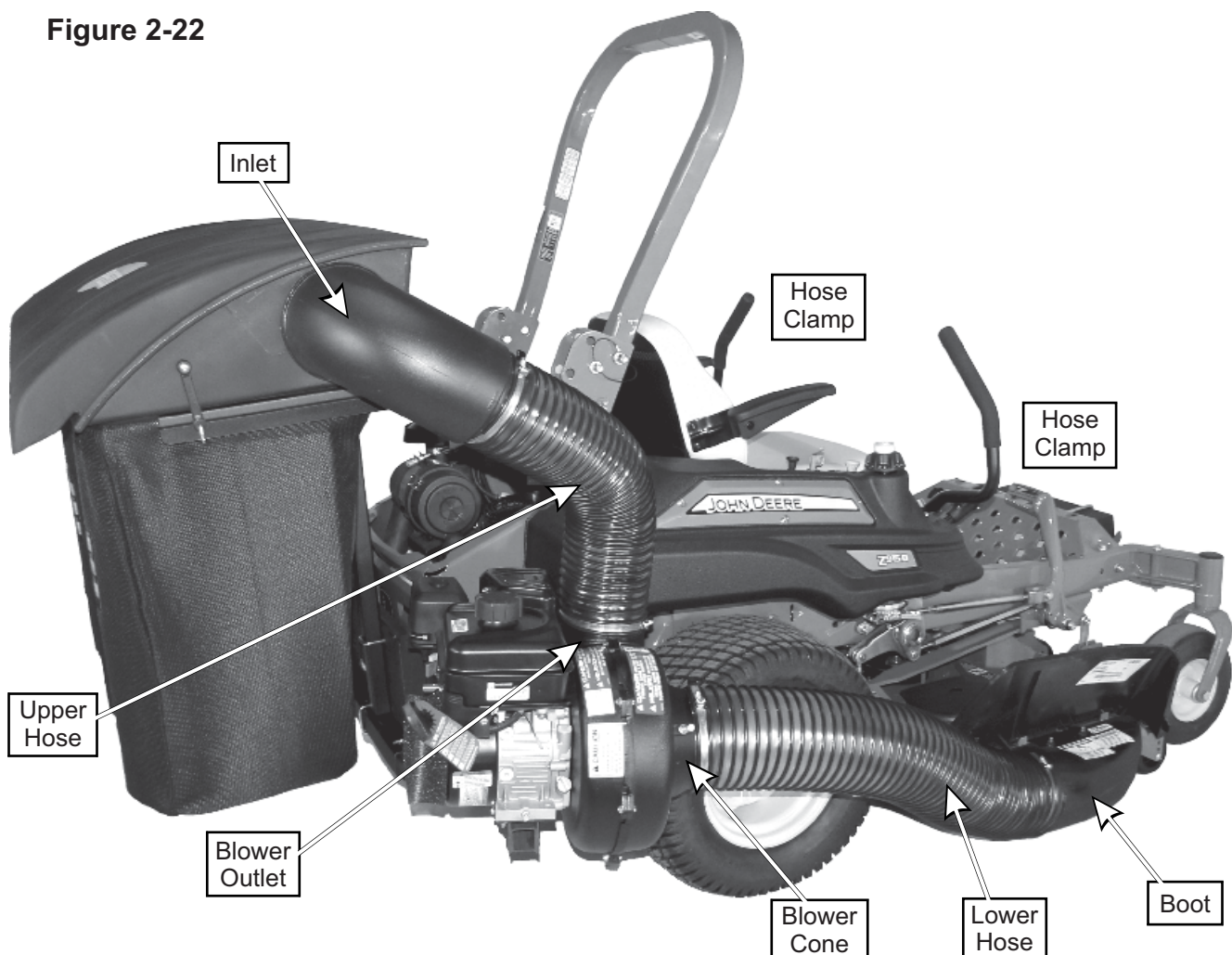



## 2-24 Impeller Blade Removal/Replacement

To gain impeller blade (#1) access, first remove the blower cone (#2) from the blower housing, located on the PTO assembly P#(A1821), by removing two blower cone bolts and nuts (#3). Next, remove the blower housing front (#4) by removing seven bolts and nuts (#5) around the outer housing edge. Refer to Figure 2-23.

**To Remove:** First, remove one 3/8"-16 x 1-1/2" HHCS P#(K1211) (#6), one taper-lock bushing washer P#(K0278) (#7) and one spacer bushing P#(S3242) (#8) from the taper-lock bushing (#9). See Figure 2-23. Next, remove two 1/4"-20 x 1" HHCS (#10) and place them into the threaded holes (#11) of the taper-lock bushing P#(S4302). Last, gradually thread each bolt evenly into the taper-lock bushing, forcing the blade to break-away from the taper-lock bushing.

### Tips on removing impeller blade;

- 1 - Try carefully hitting the base of the impeller blade (#1), between each vein (#12), with a rubber mallet to loosen the taper-lock bushing hold.
- 2 - Spray break-free lubricant into the surrounding areas of the taper-lock bushing (#9) and repeat Tip 1.

**To Replace:** First, place the impeller blade (#1) over the drive shaft (#13). Next, slide the taper-lock bushing (#9) on to the drive shaft and into the impeller blade, aligning the **non-threaded** holes (#14) of the taper-lock bushing to the threaded holes of the impeller blade. Then, fasten by using two 1/4"-20 x 1" HHCS (#10), one spacer bushing (#8) one taper lock bushing washer (#7), and one 3/8"-16 x 1-1/2" HHCS (#6). Torque all bolts to the specifications located in the chart towards the back of this manual. Last, rotate the impeller blade to ensure that the blade is clear of contact on all sides of the blower housing.

Figure 2-23

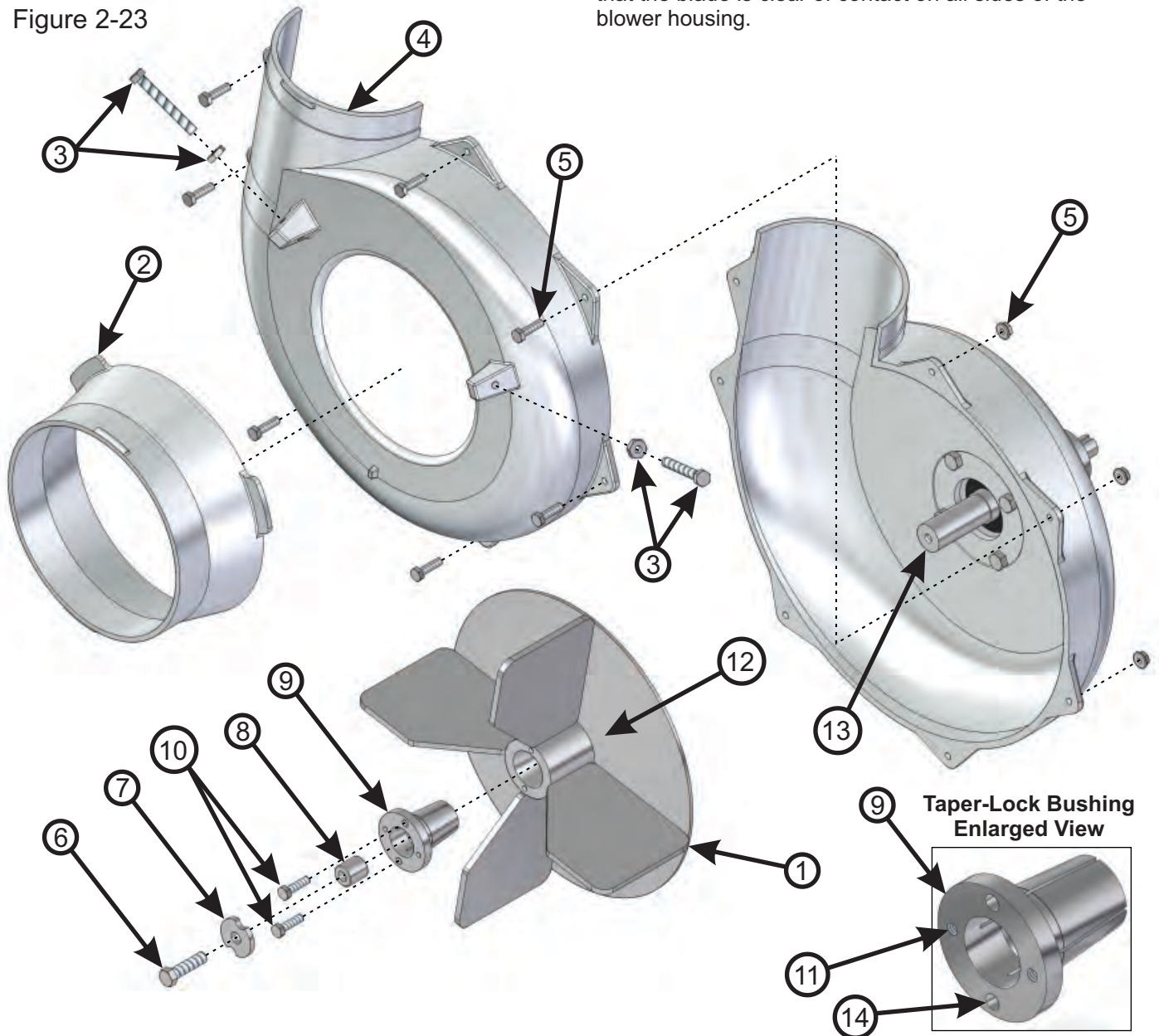

## 2-24 Weight Kit Installation

A custom front counterweight kit must be installed on your mower before operating the collection system. If equipped, remove the existing weight from the front mower frame. Refer to Figure 2-24a.

Attach the weight bracket P#(B0600) to the front frame of the mower, using the existing mounting holes in the frame. Secure the weight bracket using (2) 1/2"-13 x 1-1/4" HHCS P#(K1232) and (2) 1/2"-13 nylon flange locknuts P#(K2012). Refer to Figure 2-24b for weight bracket orientation before mounting.

**NOTE:** It is recommended that (2) people install the weight bar. Using a floor jack or similar device, position the weight bar P#(B0035) under the weight bracket as shown in Figure 2-25b. While one person helps to keep the weight bar in position, the other person will secure the weight bar to the weight bracket. Use (2) 1/2"-13 u-bolts and P#(K0331) and (4) 1/2"-13 nylon flange locknuts P#(K2012) to secure the weight bar.

Figure 2-24a

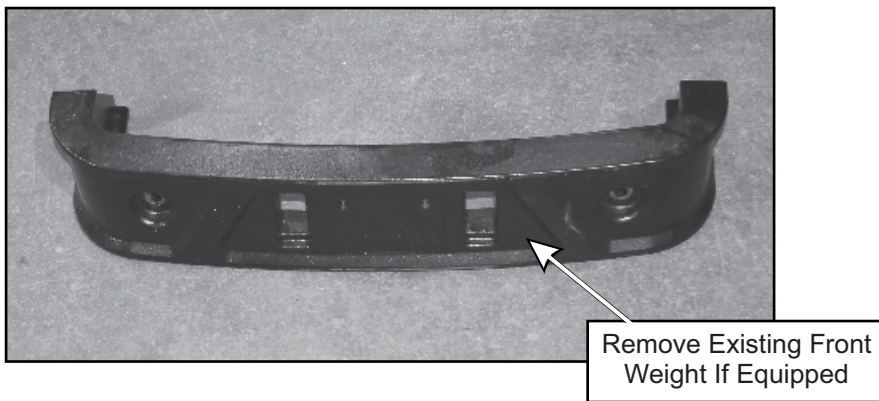
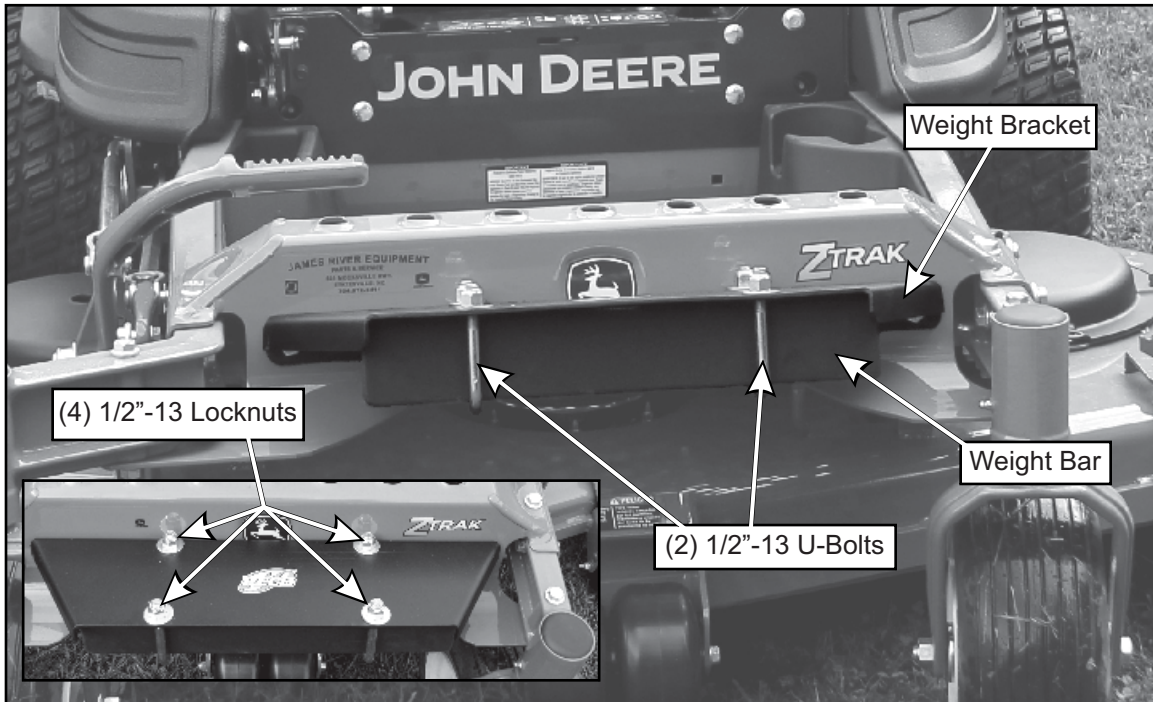

Figure 2-24b



## 2-25 Throttle Cable Installation

### NOTE: Engine Driven Models Only

To install the throttle cable kit to the ROPS (roll over protection system), place the 3/8" U-Bolt P#(K0136) onto the ROPS with the threads facing the front of the mower. Next slide on the throttle mount plate assembly P#(A0666) with the rivets also facing toward the front of the mower. Tighten the throttle mount plate assembly securely to the ROPS using (2) 3/8"16 nylon flange lock nuts P#(K2038) (Figure 2-25a). With the throttle cable facing toward the engine/blower/blade assembly, place the throttle base plate over the rivets, Slide the throttle cable kit to the right, moving the smaller end of the slot over the rivets. When positioned correctly, the throttle spring plate will snap into place (Figure 2-25b).

To remove the throttle cable kit, lift the throttle spring plate and slide the throttle kit to the left.

Route cable over the upper hose as shown in Figure 2-25c.

Figure 2-25c

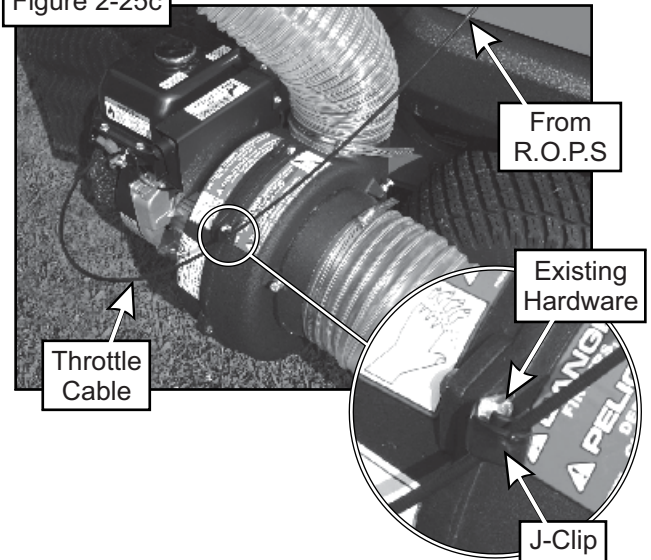

Secure the throttle cable to the blower housing assembly using (1) J-Clip P#(K1455). Use the existing hardware from the blower housing to secure the J-Clip, as shown in Figure 2-25c.

To fasten the throttle cable end to the engine, place the throttle control lever into the "stop" position. Rotate the engine throttle lever to the "stop" position. Thread the wire end of the throttle cable into the engine throttle lever eyelet and tighten the screw. Fasten the throttle cable sleeve to the clamp on the engine throttle (Figure 2-25d). Rotate the throttle control lever into the "fast" position to check for proper installation.

**NOTE:** Cable sleeve may need to be cut, depending on the engine type. Once throttle cable is attached, lift the plastic top assembly and make sure that the throttle cable does not interfere with the movement of the plastic top.

Figure 2-25a

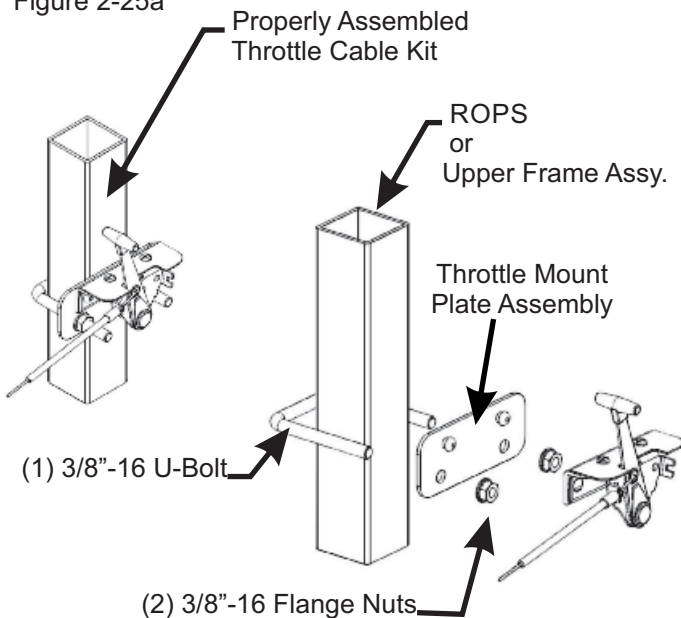

Figure 2-25d

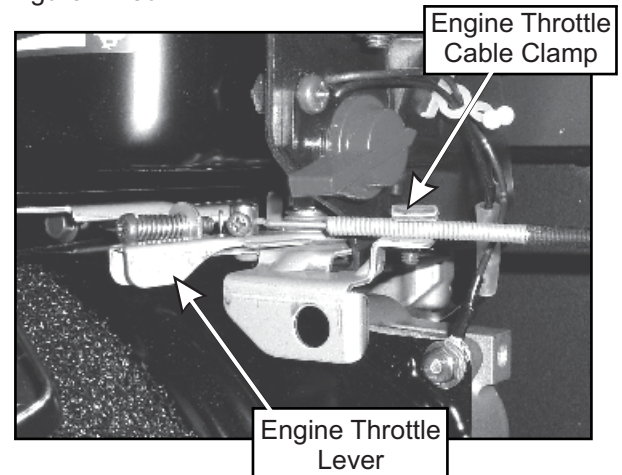
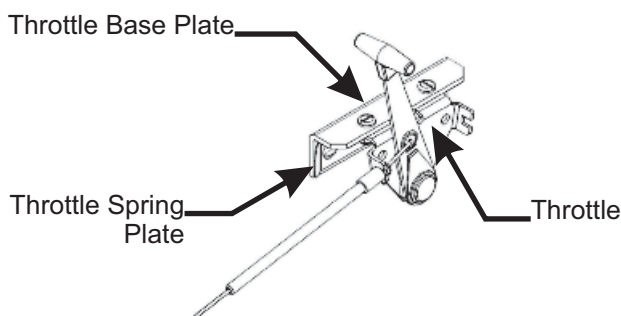

Figure 2-26b





## 2-26 Installation/Removal Of Collection Bags

### IMPORTANT!

To prevent bag wear, install (2) red plastic end caps P#(J0274), as shown in Figure 2-26a, on each bag ring before installing bags.

Figure 2-26a

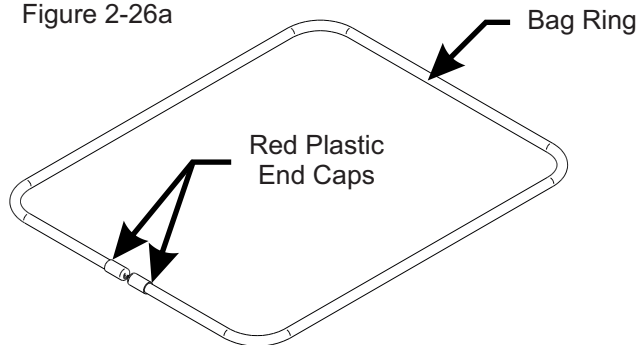

To install the bag onto the bag ring, place the seam openings of the bag onto the bag ring openings and turn the bag one full turn (360°) so the plastic end caps are located opposite to the opening in the bag (Figure 2-26b). Do this for each of three bags.

Figure 2-26b

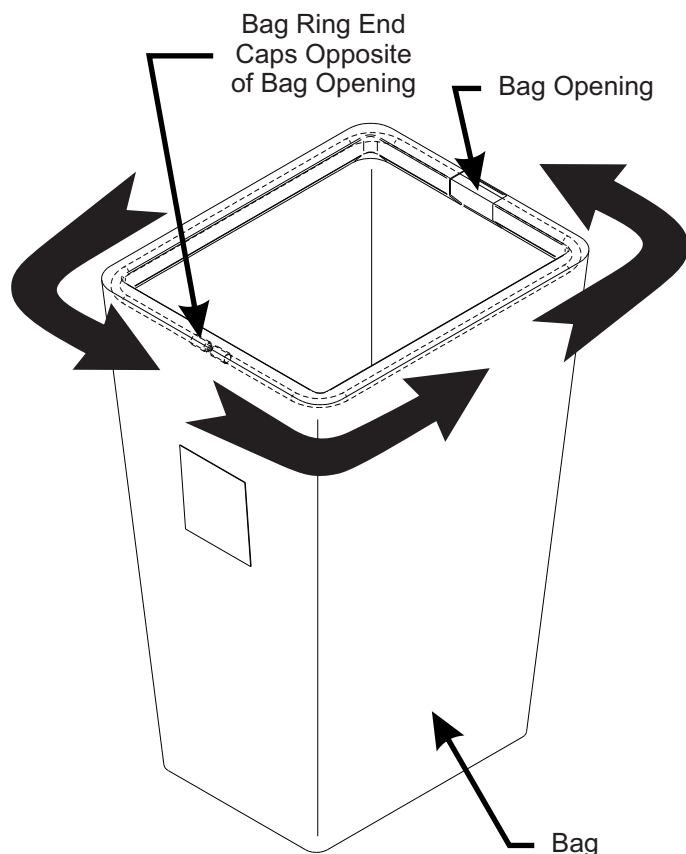

Install the completed assemblies onto the support frame and close the plastic top. Fasten both draw-latches to hold the plastic top closed (Figure 2-26c).

Figure 2-26c

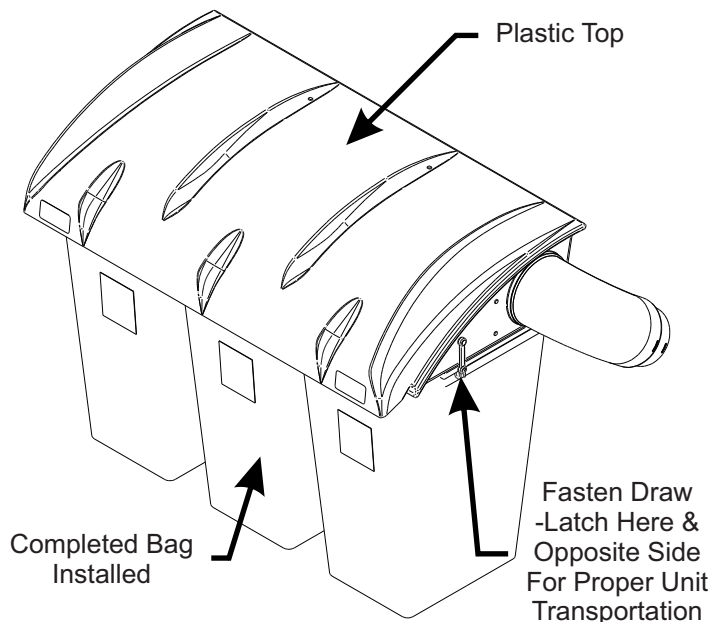

To empty the bag, first unlatch and lift top, next remove the bag and bag ring by sliding rearward, then grasp the loop on the bottom of the bag, and last turn it upside down to empty the collected debris (Figure 2-26d). Repeat for the other bags. Reinstall all bags, line with plastic bags if desired, close the plastic top and reattach the draw latches.

Figure 2-26d

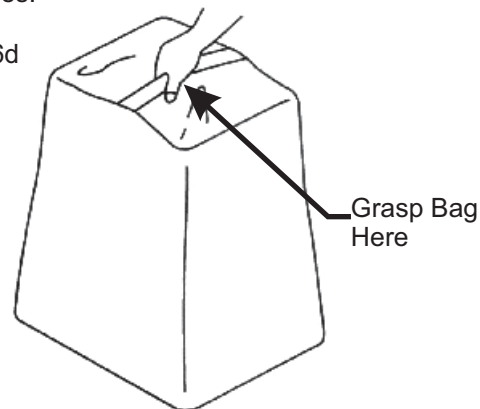

Plastic lawn and leaf bags, 33 gallon size, may be used inside the cloth bags. Be sure to leave enough plastic bag hanging over the frame so the plastic bags can be twist tied before emptying (Figure 2-26e).

Figure 2-26e

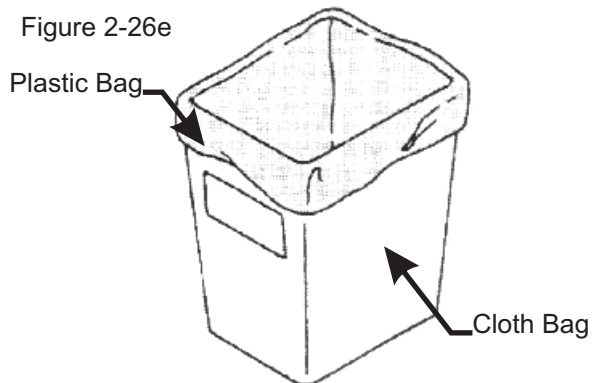



# Exploded Parts View

## A1158 Top Assembly

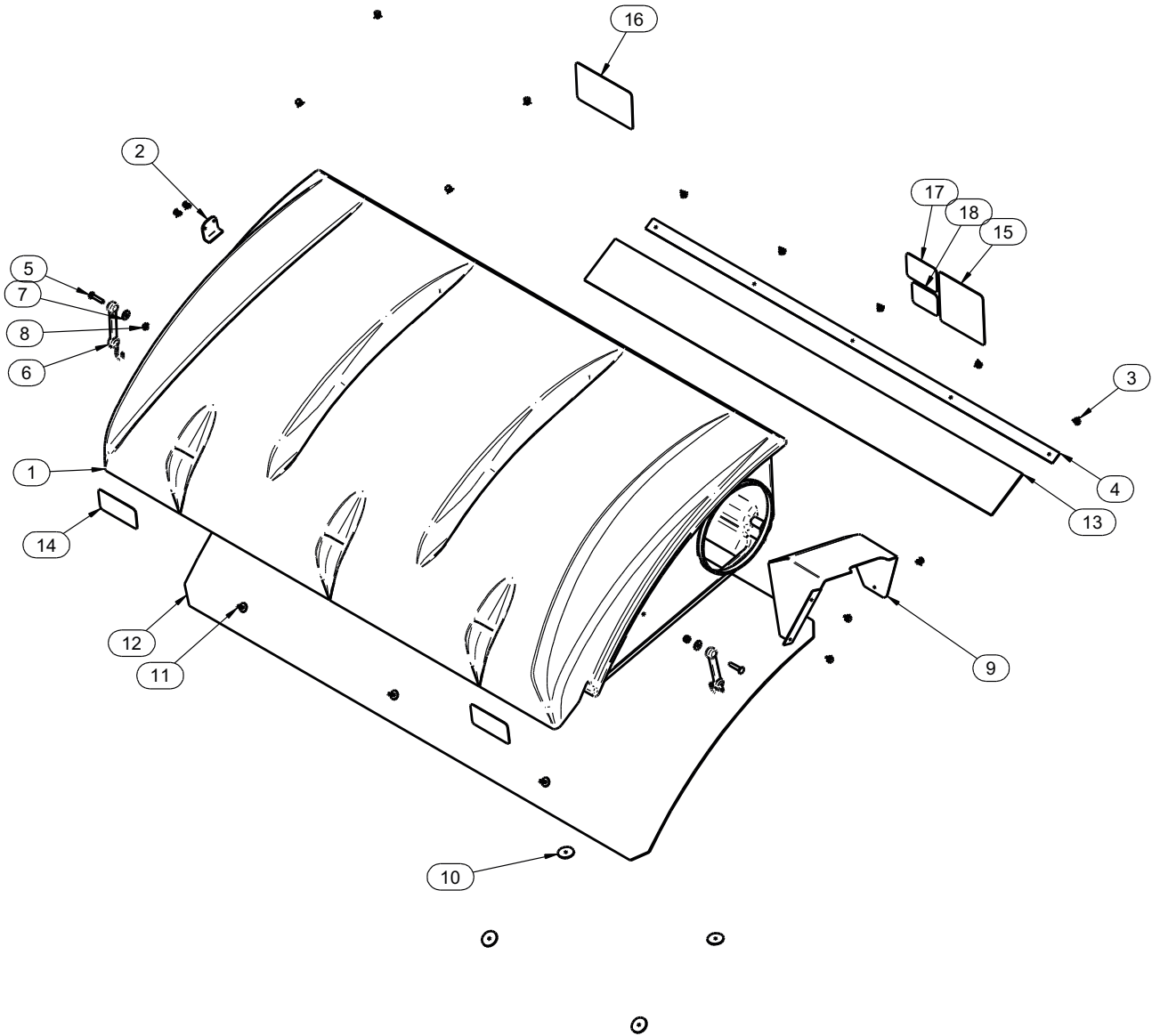

Item #	Doc #	Title	Qty
1	V0022	PRO 3 BAGGER TOP	1
2	B0676	Hinge Stop Pl.	1
3	K0114	BLACK PLASTIC RIVET	14
4	C0069	DUST GUARD BRACE	1
5	K1030	1/4"-20 x 1-1/4" CARRIAGE BOLT	2
6	J4009	SHORT RUBBER STRAP W/ S HOOK	2
7	K0037	1/4" FLAT WASHER .75 OD x .314 ID x .060 T	2
8	K1128	1/4"-20 NYLOC NUT	2
9	C0026	GRASS DEFLECTOR	1
10	K0062	3/16" x 1-1/2" FENDER WASHER, Z	4
11	K1265	BLACK PANEL RETAINER	3
12	V1120	Black Plastic Screen	1
13	V1118	DUST GUARD	1
14	R1057	2" x 4" Red Reflector Label	2
15	R1069	Warning - Turn Off Blower Label	1
16	R1065	Made In USA Label	1
17	R1054	Important Check Hoses	1
18	R1051	Warning - Use Hearing Protection	1

# A1841\_01 PTO Arm Assembly

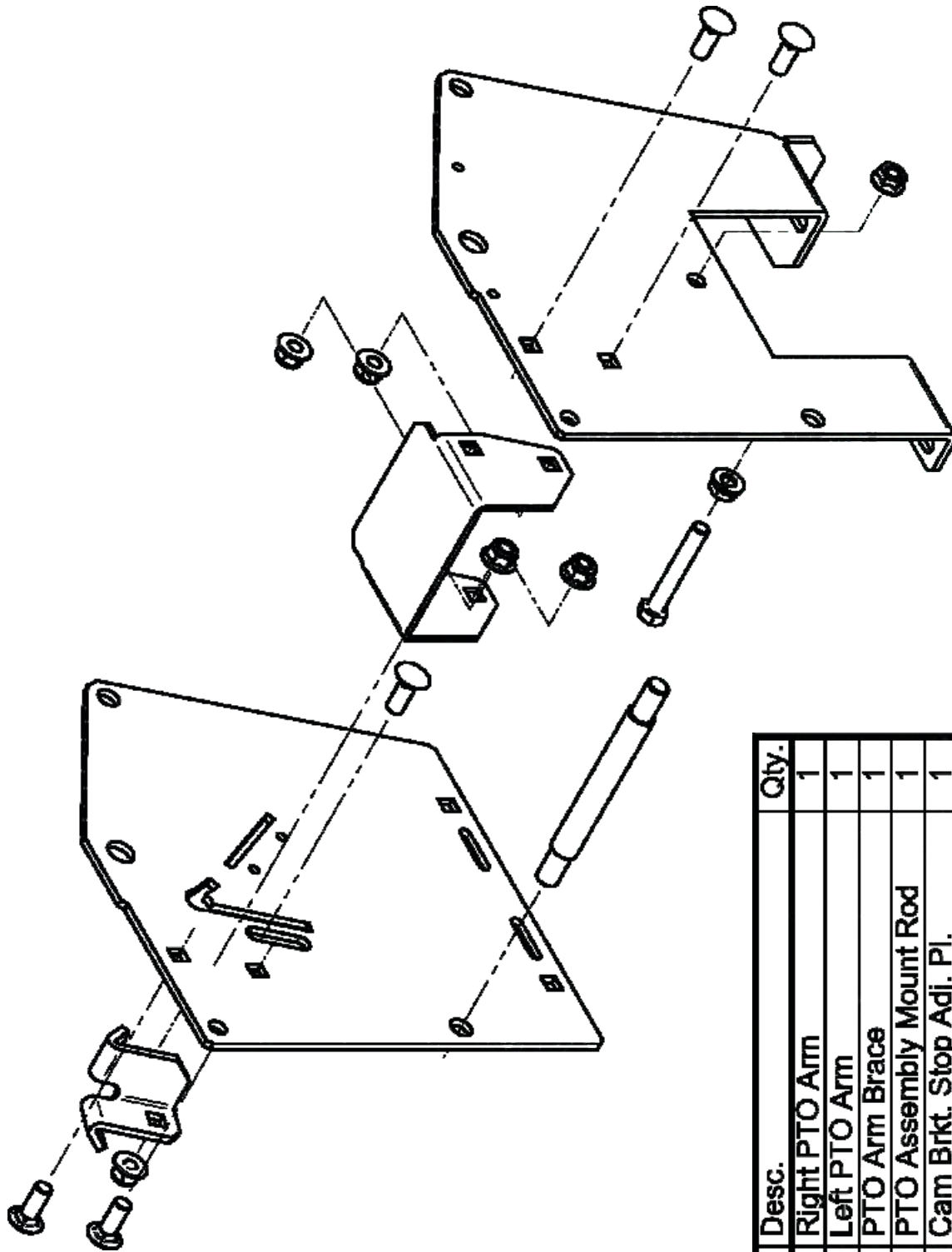

Item#	Part#	Desc.	Qty.
1	B0265 01	Right PTO Arm	1
2	B0266 01	Left PTO Arm	1
3	B0268 01	PTO Arm Brace	1
4	B0271 01	PTO Assembly Mount Rod	1
5	B0024 01	Cam Brkt. Stop Adj. Pl.	1
6	K1215	Flange Nut 3/8"-16	2
7	K1197	3/8"-16X21/2" HHCS	1
8	K1182	Carriage Bolt 3/8"-16x1"	5
9	K2038	Ny-Flange Lock Nut 3/8"-16	5

# A1941\_01 PTO Base Assembly Exploded Parts View

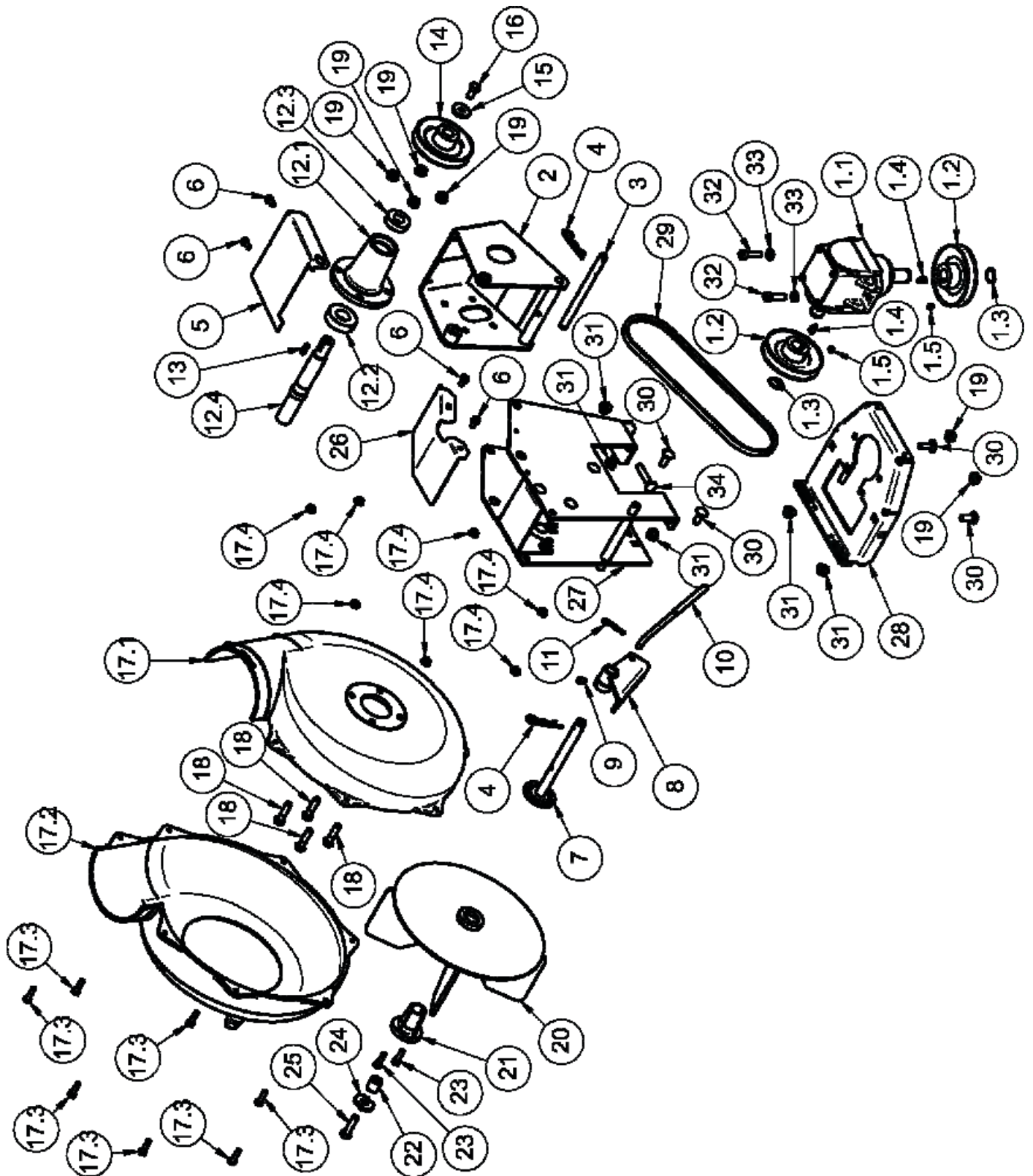



## A1941\_01 PTO Base Assembly Exploded Parts List

Item#	Part#	Desc.	Qty.
1	A0429	Gear Box Assy.	1
1.1	A0431	Gearbox	1
1.2	A0498	Pulley Assy. / GearBox	2
1.3	K0360	Snap Ring / 7/8"Shaft	2
1.4	J0272	Woodruff Key #9	2
1.5	K0035	Set Screw 5/16" -18x1/4" CupPoint	2
2	A0144	Blower Mnt. Brkt. Assy.	1
3	B1755	BLOWER PIVOT ROD	1
4	K0086	Hair Pin Clip.125ODx2.50	2
5	B0121	Blower Belt Guard	1
6	K0353	HWHTCS 1/4" -20x1/2"	4
7	A0604	PTO HANDLE MOUNT ASSY	1
8	A0422	CAM BRACKET ASSEMBLY	1
9	K0356	3/8"-16 TAPERED SET SCREW	1
10	K0326	BELT TENSION ROD 3/8"-16	1
11	K0130	.091ODx1.625L HAIR PIN CLIP	1
12	A0306	PTO Shaft Assy.	1
12.1	E0121	PTO Shaft Housing	1
12.2	N0147	Bearing (2.0472OD,0.9843ID,0.5906W)	1
12.3	N0148	Bearing (1.625OD,0.750ID,0.4375W)	1
12.4	B1758	PTO Shaft	1
13	J0254	Key / 3/16" x3/16" x3/4"	1
14	M0228	Pulley / Impeller Shaft	1
15	K1446	PTO Housing Washer	1
16	K1190	HHCS / 3/8"-16x3/4"	1
17	E4004A	BLOWER HSG. ASSY.	1
17.1	E4004B	BLOWER HSG. BACK	1
17.2	E4004F	BLOWER HSG. FRONT	1
17.3	K1125	HHCS 1/4" -20X1" GR2	7
17.4	K1126	Flange Nut 1/4" -20	7
18	K1193	HHCS 3/8" -16X1-1/2"GR5	4
19	K1215	Flange Nut 3/8"-16	6
20	A0645	4-Blade Impeller Assy	1
21	S4302	TAPER - LOCK BUSHING	1
22	S3242	Spacer Bushing / .750IDx.380IDx.830L	1
23	K1225	HHCS 1/4" -20X1" GR8	2
24	K0278	Double Indented Washer 7/16"1.375ODx.440IDx.179T	1
25	K1211	3/8"-16x1-1/2"HHCS GR8	1
26	B0270	PTO Arm Guard	1
27	A1804_01	PTO Arm Assembly	1
28	A0624_01	Base Plate Assembly	1
29	M0250	A30K KEVLAR BELT	1
30	K1182	Carriage Bolt 3/8"-16x1"	4
31	K2038	Ny-Flange Lock Nut 3/8"-16	5
32	K0309	3/8"-16x1-1/4"SHCS	2
33	K0048	Lock Washer 3/8"	2
34	K1184	Carriage Bolt 3/8"-16x2"	1

# A0623 PTO Assembly w/ Small Pulley Guard Exploded Parts View

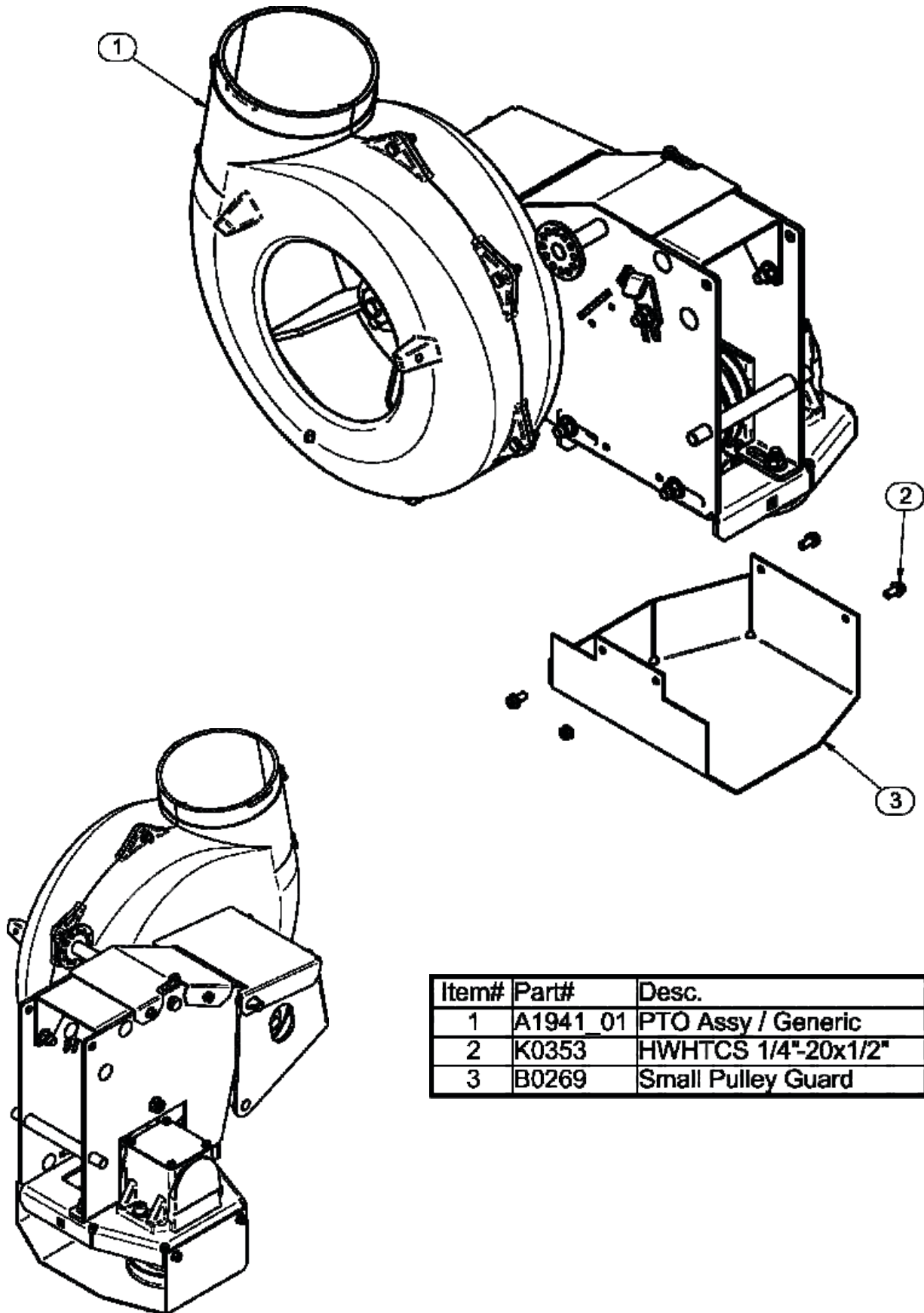

Item#	Part#	Desc.	Qty.
1	A1941_01	PTO Assy / Generic	1
2	K0353	HWHTCS 1/4"-20x1/2"	4
3	B0269	Small Pulley Guard	1

# A1950 PTO Base Assembly w/ Heat Guard Exploded Parts List

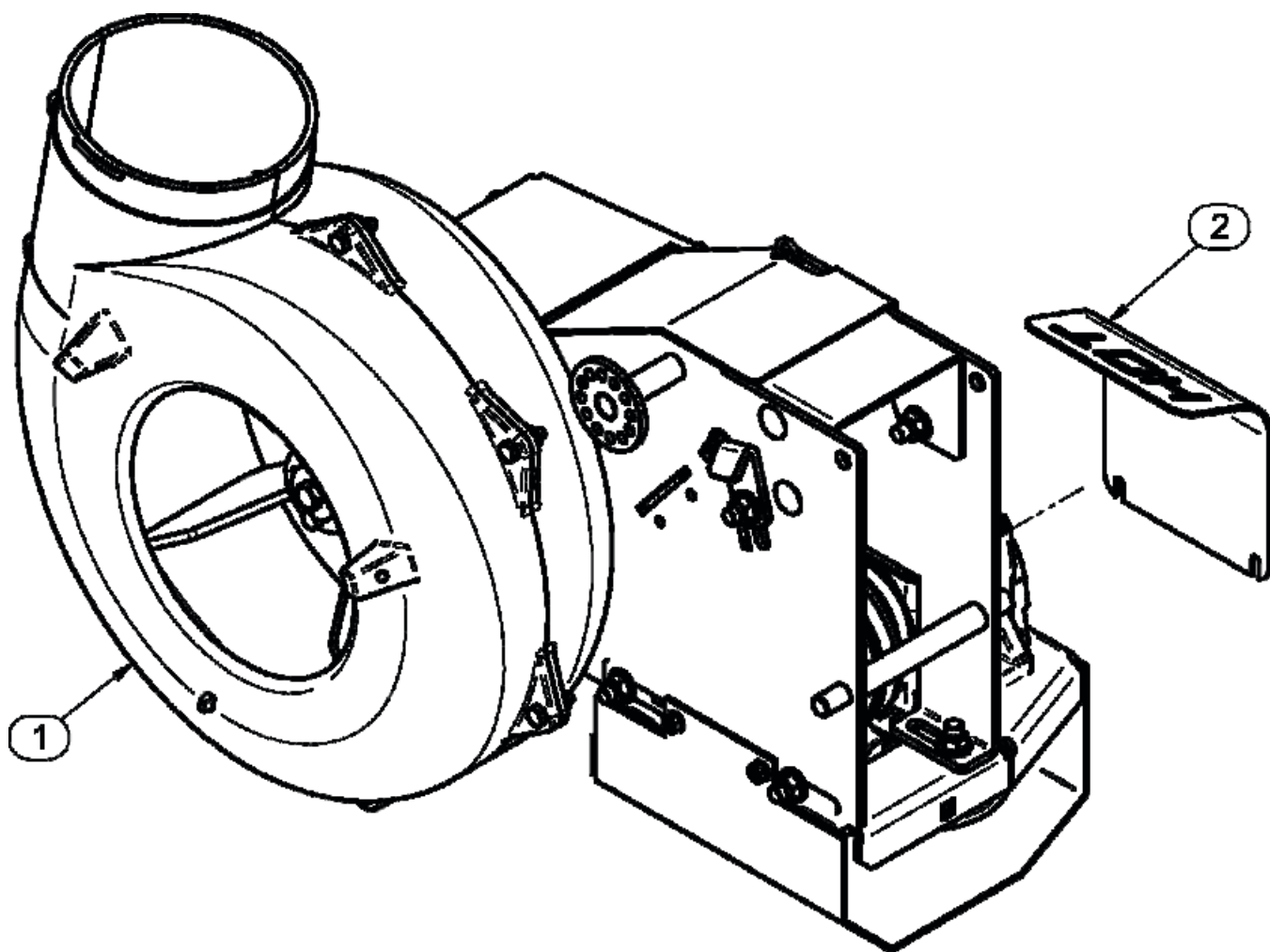

Item#	Part#	Description	Qty.	Rev#
1	A0623	PTO Assy / Small Pulley Guard	1	5
2	B0833	Gear Box Heat Guard	1	



# Unit Model #: 06131510

**Mower & Type:** John Deere Z915B, Z920M, Z920R, Z925M EFI, Z930R

**Engine Type:** Kohler - CV740, FCV740 / Kawasaki - FX730V, FX801V

**Deck Size & Type:** 54" 7 Iron II - Commercial

**Owner's Manual:** Q0477

**Revision #:** Final Release 10/31/2013

**Vac Type:** Pro 3 Bagger (15 Cu. Ft.)

**Drive Type:** Briggs & Stratton 6.5HP Vanguard

**Fits Year[s]:** 2013 & Newer

## A1971 Vac Kit



(1) A1158 Top Assembly w/ PECO Labels



(1) V0025 6" & 7" Plastic Inlet



(1) F0060 6" x 29" Upper Hose



(2) J0060 6" Hose Clamps



(1) HB0597 Vac Kit Hardware Bag

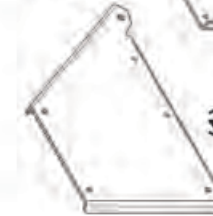

(1) B0865 Lt. Frame Bracket

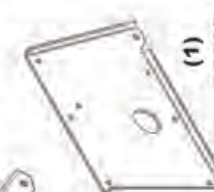

(1) B0866 Rt. Frame Bracket

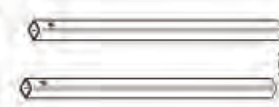

(2) B0640 29" Lower Mount Tubes

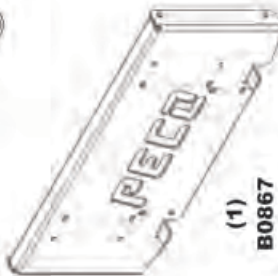

(1) B0867 Rear Frame Bracket

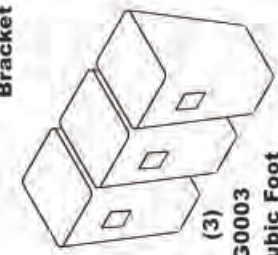

(3) G0003 4 Cubic Foot Collections Bags

## A1972 Mount Kit



(1) F0070 7" x 40" Lower Hose



(2) J0070 7" Hose Clamps



(1) HB0594 Mount Kit Hardware Bag



(1) B1117 Outer Engine Mount Tube



(1) A0274 Engine Mount Arm Assembly

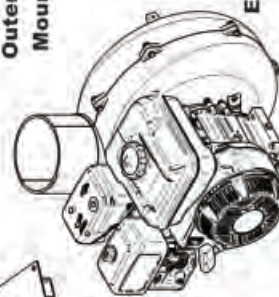

(1) A639 Engine/Blower Blade Assy.



(1) E6004 7" Blower Cone

## A1771 54" Boot Kit



(1) HB0412 Hardware Bag

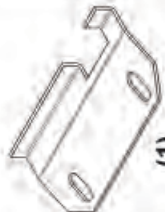

(1) B0001 Boot Plate



(1) E1103 Boot

## A2140 Weight Kit



(4) Y0025 28 lbs Suitcase Weight

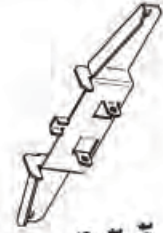

(1) B1016 Weight Bracket



(1) HB0699 Weight Kit Hardware Bag

## A0619 Throttle Kit



(1) A0666 Throttle Mnt. Pl. Assembly

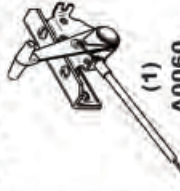

(1) A0060 70" Throttle Cable



(1) HB0249 Hardware bag



# Unit Model #: 06131513

**Mower & Type:** John Deere Z915B, Z920M, Z925M EFI, Z930M, Z930M EFI, Z930R, Z950R, Z960R

**Engine Type:** Kohler - CV740, FCV740, ECV749 / Kawasaki - FX730V, FX801V, FX850V, FX921V

**Deck Size & Type:** 60" 7 Iron II - Commercial

**Owner's Manual:** Q0477

**Revision #:** Final Release 10/31/2013

**Vac Type:** Pro 3 Bagger (15 Cu. Ft.)

**Drive Type:** Briggs & Stratton 6.5HP Vanguard

**Fits Year[s]:** 2013 & Newer

## A1971 Vac Kit



(1) A1158 Top Assembly w/ PECO Labels  
(1) V0025 6" & 7" Plastic Inlet

## A1979 Mount Kit

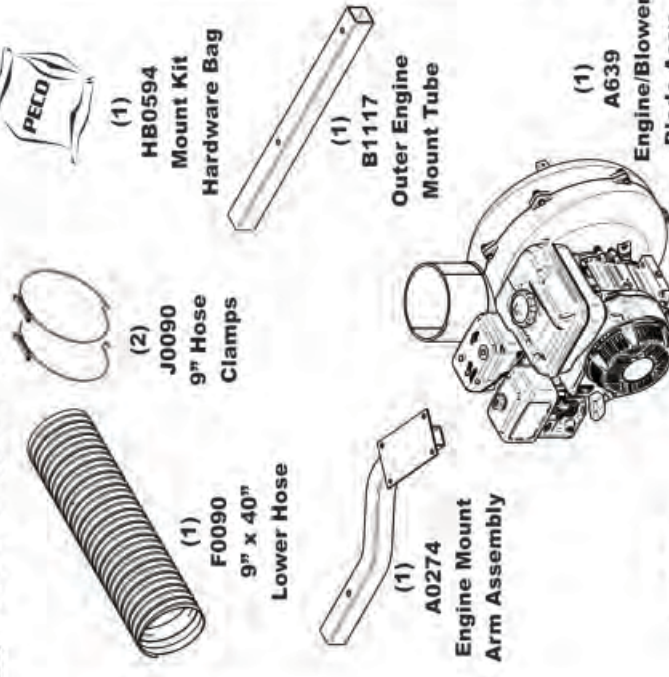

(1) F0090 Lower Hose 9" x 40"  
(2) J0090 9" Hose Clamps  
(1) A0274 Engine Mount Arm Assembly  
(1) B1117 Outer Engine Mount Tube  
(1) HB0594 Mount Kit Hardware Bag

## A1767 60" Boot Kit

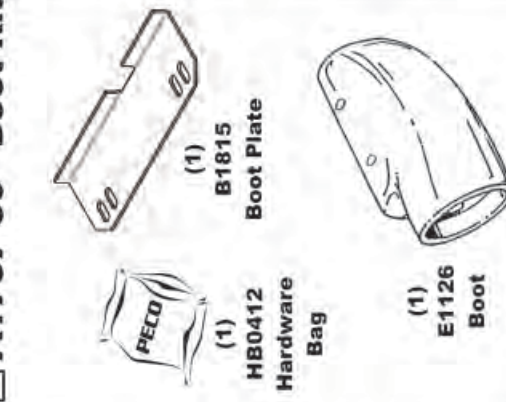

(1) HB0412 Hardware Bag  
(1) B1815 Boot Plate  
(1) E1126 Boot

## A2140 Weight Kit

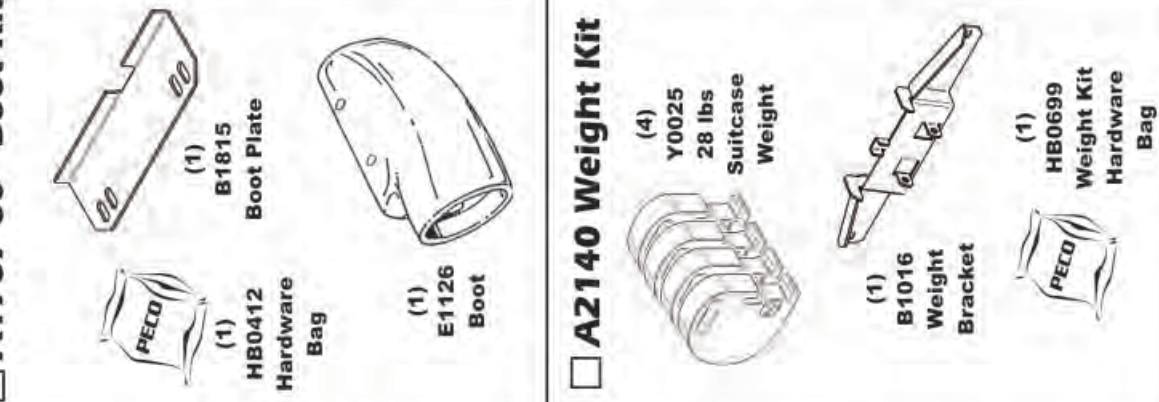

(4) Y0025 28 lbs Suitcase Weight  
(1) B1016 Weight Bracket  
(1) HB0699 Weight Kit Hardware Bag

## A0619 Throttle Kit

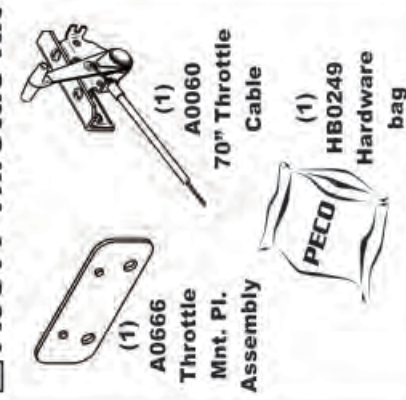

(1) A0666 Throttle Mnt. Pl. Assembly  
(1) A0060 70" Throttle Cable  
(1) HB0249 Hardware bag

## A0619 Throttle Kit



(1) E6020 9" Blower Cone

## A0619 Throttle Kit

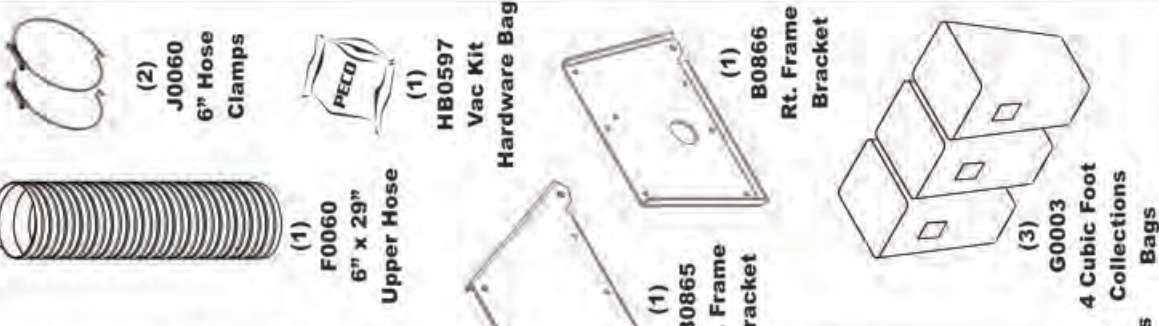

(2) J0060 6" Hose Clamps  
(1) F0060 6" x 29" Upper Hose  
(1) HB0597 Vac Kit Hardware Bag  
(1) B0865 Lt. Frame Bracket  
(1) B0866 Rt. Frame Bracket  
(3) G0003 4 Cubic Foot Collections Bags  
(2) B0640 29" Lower Mount Tubes

## A0619 Throttle Kit

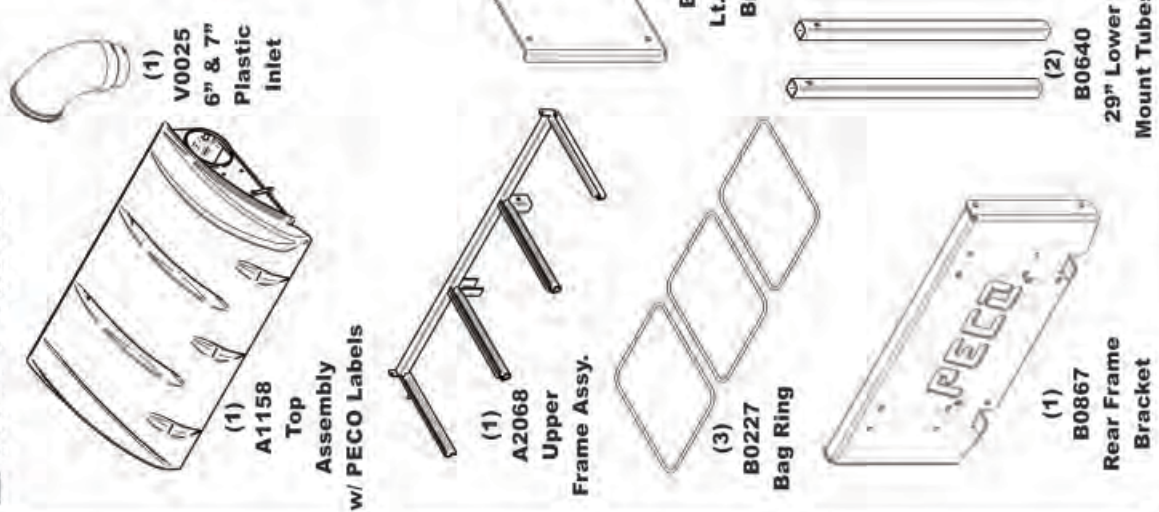

(3) B0227 Bag Ring  
(1) B0867 Rear Frame Bracket





# Unit Model #: 06131511

**Mower & Type:** John Deere Z915B, Z920M, Z920R, Z925M EFI, Z930R

**Engine Type:** Kohler - CV740, FCV740 / Kawasaki - FX730V, FX801V

**Deck Size & Type:** 54" 7 Iron II - Commercial

**Owner's Manual:** Q0477

**Revision #:** Final Release 10/31/2013

**Vac Type:** Pro 3 Bagger (15 Cu. Ft.)

**Drive Type:** Briggs & Stratton 900 Series

**Fits Year[s]:** 2013 & Newer

## A1971 Vac Kit



(1) A1158 Top Assembly w/ PECO Labels

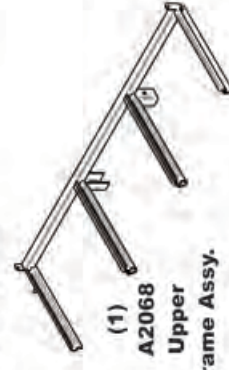

(1) A2068 Upper Frame Assy.



(3) B0227 Bag Ring

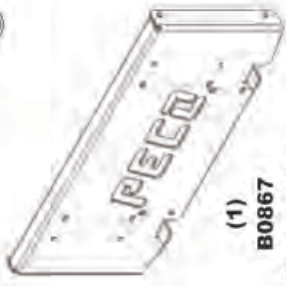

(1) B0867 Rear Frame Bracket

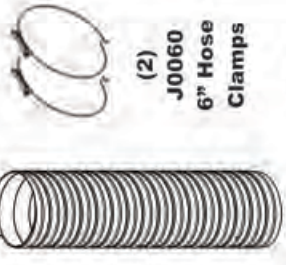

(1) F0060 6" x 29" Upper Hose



(1) HB0597 Vac Kit Hardware Bag

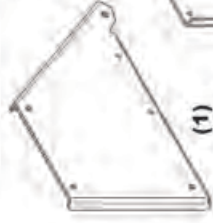

(1) B0865 Lt. Frame Bracket

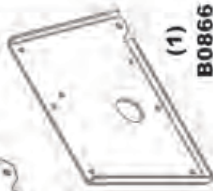

(1) B0866 Rt. Frame Bracket



(2) B0640 29" Lower Mount Tubes

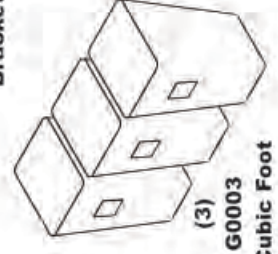

(3) G0003 4 Cubic Foot Collections Bags

## A1973 Mount Kit

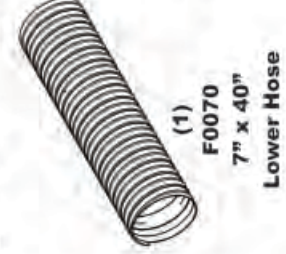

(1) F0070 7" x 40" Lower Hose

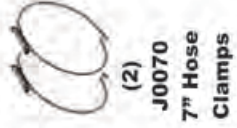

(2) J0070 7" Hose Clamps



(1) A0274 Engine Mount Arm Assembly

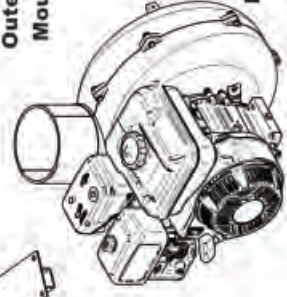

(1) A602 Engine/Blower Blade Assy.



(1) B1117 Outer Engine Mount Tube



(1) HB0594 Mount Kit Hardware Bag

## A1771 54" Boot Kit



(1) HB0412 Hardware Bag



(1) B0001 Boot Plate



(1) E1103 Boot

## A2140 Weight Kit



(4) Y0025 28 lbs Suitcase Weight

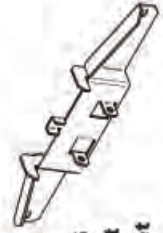

(1) B1016 Weight Bracket



(1) HB0699 Weight Kit Hardware Bag

## A0619 Throttle Kit

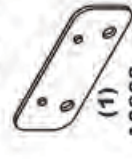

(1) A0666 Throttle Mnt. Pl. Assembly



(1) A0060 70" Throttle Cable



(1) HB0249 Hardware bag



(1) E6004 7" Blower Cone



# Unit Model #: 06131514

**Mower & Type:** John Deere Z915B, Z920M, Z925M EFI, Z930M, Z930M EFI, Z930R, Z950R, Z960R

**Engine Type:** Kohler - CV740, FCV740, ECV749 / Kawasaki - FX730V, FX801V, FX850V, FX921V

**Deck Size & Type:** 60" 7 Iron II - Commercial

**Owner's Manual:** Q0477

**Vac Type:** Pro 3 Bagger (15 Cu. Ft.)

**Drive Type:** Briggs & Stratton 900 Series

**Revision #:** Final Release 10/31/2013

**Fits Year[s]:** 2013 & Newer

## A1971 Vac Kit



(1) V0025  
6" & 7" Plastic Inlet

(1) A1158  
Top Assembly w/ PECO Labels

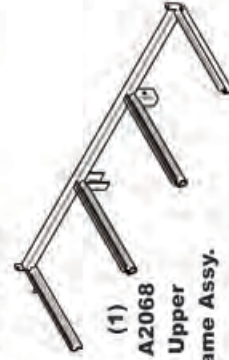

(1) A2068  
Upper Frame Assy.



(3) B0227  
Bag Ring

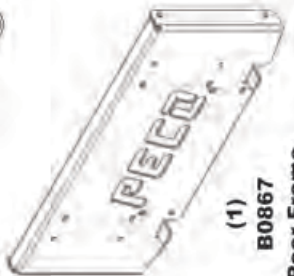

(1) B0867  
Rear Frame Bracket

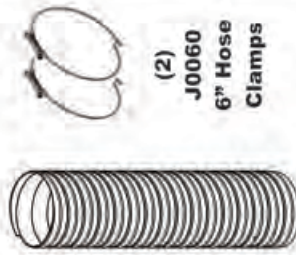

(1) F0060  
6" x 29" Upper Hose



(2) J0060  
6" Hose Clamps



(1) HB0597  
Vac Kit Hardware Bag

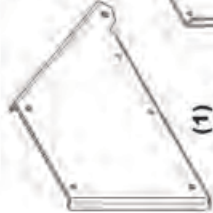

(1) B0865  
Lt. Frame Bracket

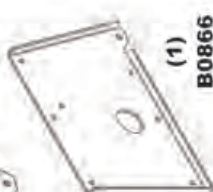

(1) B0866  
Rt. Frame Bracket

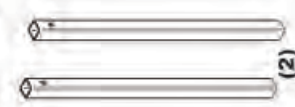

(2) B0640  
29" Lower Mount Tubes

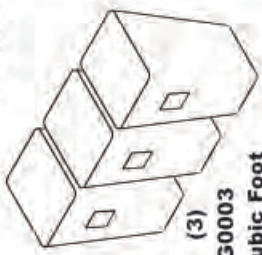

(3) G0003  
4 Cubic Foot Collections Bags

## A1980 Mount Kit



(1) F0090  
9" x 40" Lower Hose



(2) J0090  
9" Hose Clamps



(1) HB0594  
Mount Kit Hardware Bag



(1) B1117  
Outer Engine Mount Tube



(1) A0274  
Engine Mount Arm Assembly

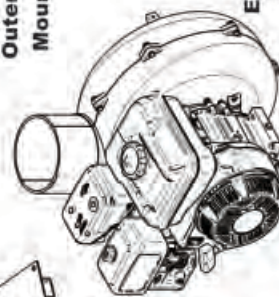

(1) A602  
Engine/Blower Blade Assy.



(1) E6020  
9" Blower Cone

## A1767 60" Boot Kit



(1) HB0412  
Hardware Bag



(1) B1815  
Boot Plate



(1) E1126  
Boot

## A2140 Weight Kit



(4) Y0025  
28 lbs Suitcase Weight

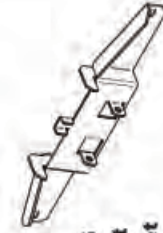

(1) B1016  
Weight Bracket



(1) HB0699  
Weight Kit Hardware Bag

## A0619 Throttle Kit



(1) A0666  
Throttle Mnt. Pl. Assembly



(1) A0060  
70" Throttle Cable



(1) HB0249  
Hardware bag



# Unit Model #: 06131512

Mower & Type: John Deere Z915B

Engine Type: Kohler CV740

Deck Size & Type: 54" 7 Iron II - Commercial

Owner's Manual: Q0477

Revision #: Final Release 10/31/2013

Vac Type: Pro 3 Bagger (15 Cu. Ft.)

Drive Type: PTO Driven

Fits Year[s]: 2013 & Newer



## A1971 Vac Kit



(1) A1158 Top Assembly w/ PECO Labels



(1) V0025 6" & 7" Plastic Inlet

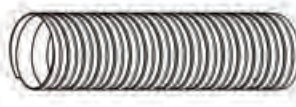

(1) F0060 6" x 29" Upper Hose



(2) J0060 6" Hose Clamps



(1) HB0597 Vac Kit Hardware Bag

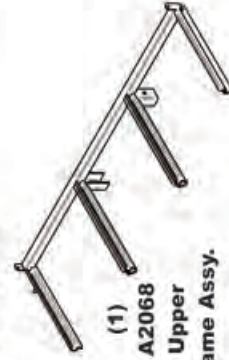

(1) A2068 Upper Frame Assy.



(3) B0227 Bag Ring

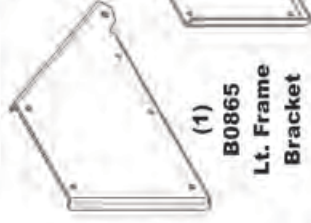

(1) B0865 Lt. Frame Bracket

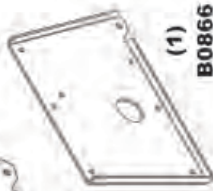

(1) B0866 Rt. Frame Bracket



(2) B0640 29" Lower Mount Tubes

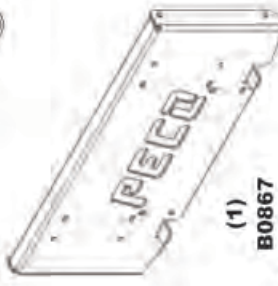

(1) B0867 Rear Frame Bracket

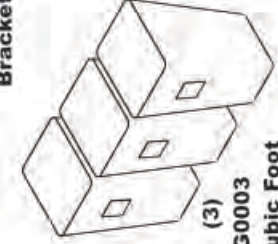

(3) G0003 4 Cubic Foot Collections Bags

## A1970 Mount Kit

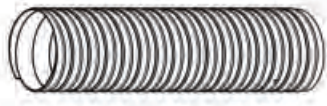

(1) F0070 7" x 40" Lower Hose



(2) J0070 7" Hose Clamps



(1) M0239 A56K Kevlar Belt



(1) HB0595 Mount Kit Hardware Bag



(1) B0868 Lt. PTO Mount Plate



(1) B0869 Rt. PTO Mount Plate



(1) A1142 PTO HANDLE ASSY.

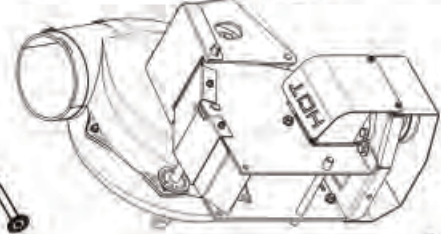

(1) A1950 PTO Assembly



(1) B0736 PTO Stop Plate



(1) E6004 7" Blower Cone

## A1771 54" Boot Kit



(1) HB0412 Hardware Bag

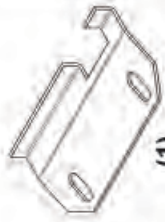

(1) B0001 Boot Plate

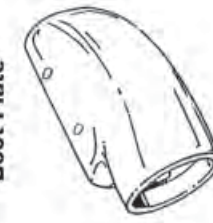

(1) E1103 Boot

## A2140 Weight Kit



(4) Y0025 28 lbs Suitcase Weight

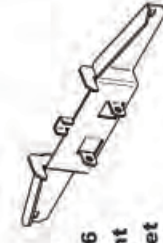

(1) B1016 Weight Bracket



(1) HB0699 Weight Kit Hardware Bag



# Unit Model #: 06131515

Mower & Type: John Deere Z915B

Engine Type: Kohler CV740

Deck Size & Type: 60" 7 Iron II - Commercial

Owner's Manual: Q0477

Revision #: Final Release 10/31/2013

Vac Type: Pro 3 Bagger (15 Cu. Ft.)

Drive Type: PTO Driven

Fits Year[s]: 2013 & Newer

## A1971 Vac Kit

## A1767 60" Boot Kit

(1) A1158 Top Assembly w/ PECO Labels

(1) V0025 Plastic Inlet

(1) F0060 6" x 29" Upper Hose

(1) F0090 9" x 40" Lower Hose

(2) J0060 6" Hose Clamps

(2) J0090 9" Hose Clamps

(1) HB0597 Vac Kit Hardware Bag

(1) A2068 Upper Frame Assy.

(1) B0865 Lt. Frame Bracket

(1) B0866 Rt. Frame Bracket

(2) B0640 29" Lower Mount Tubes

(3) G0003 4 Cubic Foot Collections Bags

(1) B0867 Rear Frame Bracket

## A1975 Mount Kit

(1) M0239 A56K Kevlar Belt

(1) HB0596 Engine Pulley Hardware Bag

(1) HB0595 Mount Kit Hardware Bag

(1) B0868 Lt. PTO Mount Plate

(1) B0869 Rt. PTO Mount Plate

(1) A1142 PTO HANDLE ASSY.

(1) E6020 9" Blower Cone

(1) A1950 PTO Assembly

(1) B0736 PTO Stop Plate

## A2140 Weight Kit

(1) B1815 Boot Plate

(1) HB0412 Hardware Bag

(1) E1126 Boot

(4) Y0025 28 lbs Suitcase Weight

(1) B1016 Weight Bracket

(1) HB0699 Weight Kit Hardware Bag





# Unit Model #: 06131516

Mower & Type: John Deere Z930R

Engine Type: Kawasaki FX801V

Deck Size & Type: 54" 7 Iron II - Commercial

Owner's Manual: Q0477

Revision #: Final Release 10/31/2013

Vac Type: Pro 3 Bagger (15 Cu. Ft.)

Drive Type: PTO Driven

Fits Year[s]: 2013 & Newer

## A1971 Vac Kit

- (1) A1158 Top Assembly w/ PECO Labels
- (1) V0025 6" & 7" Plastic Inlet
- (2) J0060 6" Hose Clamps
- (1) F0060 6" x 29" Upper Hose
- (1) HB0597 Vac Kit Hardware Bag
- (1) B0865 Lt. Frame Bracket
- (1) B0866 Rt. Frame Bracket
- (3) G0003 4 Cubic Foot Collections Bags
- (2) B0640 29" Lower Mount Tubes
- (1) A2068 Upper Frame Assy.
- (3) B0227 Bag Ring
- (1) B0867 Rear Frame Bracket

## A1976 Mount Kit

- (1) M0239 A56K Kevlar Belt
- (1) HB0608 Engine Pulley Hardware Bag
- (2) J0070 7" Hose Clamps
- (1) F0070 7" x 40" Lower Hose
- (1) A1142 PTO HANDLE ASSY.
- (1) B0868 Lt. PTO Mount Plate
- (1) B0869 Rt. PTO Mount Plate
- (1) A1950 PTO Assembly
- (1) B0736 PTO Stop Plate

## A1771 54" Boot Kit

- (1) HB0412 Hardware Bag
- (1) B0001 Boot Plate
- (1) E1103 Boot

## A2140 Weight Kit

- (4) Y0025 28 lbs Suitcase Weight
- (1) B1016 Weight Bracket
- (1) HB0699 Weight Kit Hardware Bag







# Unit Model #: 06131517

Mower & Type: John Deere Z930M & Z930R

Engine Type: Kawasaki FX801V

Deck Size & Type: 60" 7 Iron II - Commercial

Owner's Manual: Q0477

Revision #: Final Release 10/31/2013

Vac Type: Pro 3 Bagger (15 Cu. Ft.)

Drive Type: PTO Driven

Fits Year[s]: 2013 & Newer

**A1971 Vac Kit**



(1) A1158 Top Assembly w/ PECO Labels



(1) V0025 6" & 7" Plastic Inlet



(1) F0060 6" x 29" Upper Hose



(2) J0060 6" Hose Clamps



(1) HB0597 Vac Kit Hardware Bag

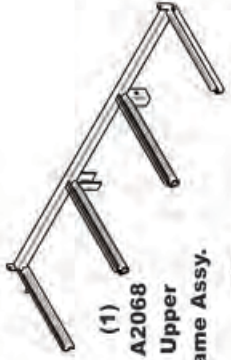

(1) A2068 Upper Frame Assy.

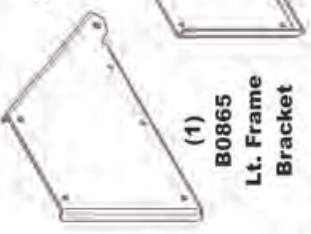

(1) B0865 Lt. Frame Bracket

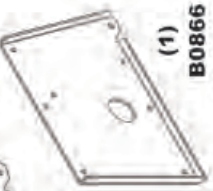

(1) B0866 Rt. Frame Bracket

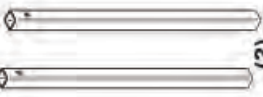

(2) B0640 29" Lower Mount Tubes

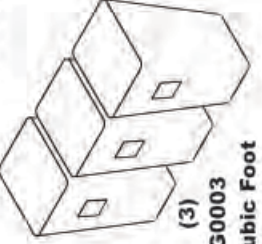

(3) G0003 4 Cubic Foot Collections Bags

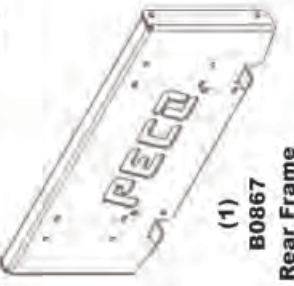

(1) B0867 Rear Frame Bracket

**A1977 Mount Kit**



(1) F0090 9" x 40" Lower Hose



(2) J0090 9" Hose Clamps



(1) M0239 A56K Kevlar Belt



(1) HB0609 Mount Kit Hardware Bag



(1) B0868 Lt. PTO Mount Plate

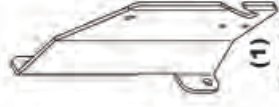

(1) B0869 Rt. PTO Mount Plate



(1) A1142 PTO HANDLE ASSY.

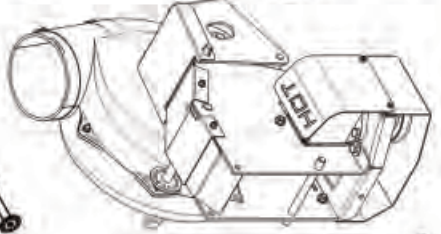

(1) A1950 PTO Assembly



(1) B0736 PTO Stop Plate



(1) E6020 9" Blower Cone

**A1767 60" Boot Kit**



(1) HB0412 Hardware Bag

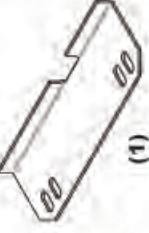

(1) B1815 Boot Plate



(1) E1126 Boot

**A2140 Weight Kit**



(4) Y0025 28 lbs Suitcase Weight

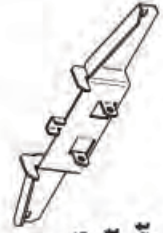

(1) B1016 Weight Bracket



(1) HB0699 Weight Kit Hardware Bag

## SECTION III OPERATING INSTRUCTIONS

### General Safety

Only qualified people familiar with this operator's manual and the mower's operator's manual should operate this machine.

### Operation And Tips On Mowing

#### PTO MODELS

- A. Perform BEFORE EACH USE the maintenance list in the next section.
- B. Start mower.
- C. With the mower at high idle speed, engage the mower deck.
- D. While seated in the operator's seat, rotate the engagement handle of the collection system away from the mower. Continue to rotate the handle until it stops in an over-center position. With the blower engaged, you can proceed to operate the control levers of the mower.

#### ENGINE DRIVEN MODELS

- A. Perform BEFORE EACH USE the maintenance list in the next section.
- B. Start the engine/blower/blade assembly.
- B. Start mower.
- C. With the mower at high idle speed, engage the mower deck.
- D. Proceed to operate the control levers of the mower.

**NOTE:** If the collection system does not appear to be collecting the grass clippings, disengage the deck and PTO assembly, then, engage the parking brake and turn the mower off. Check upper and lower hoses for any clogs. To obtain the maximum effectiveness from your collection system, the tips listed below should be followed:

- \* Watch your speed- Normal conditions will allow a speed of up to approximately 4 mph, but thick, heavy damp conditions will require reduced ground speed.
- \* Mow with sharp blades- A sharp blade cuts cleaner.
- \* Wet grass and leaves will decrease effectiveness and will increase horsepower requirements.
- \* Mow at higher cutting heights- Remove and mulch no more than 2" of grass length with each mowing. (Experts recommend not cutting off more than 1/3 of the grass blade length at any given time.)
- \* Mow twice, at different height settings, (high, then low), if grass is extra tall.
- \* Remember that horsepower requirements will vary with the mowing conditions such as type and height of turf grass, moisture content, amount of leaves, whether the terrain is flat or hilly, etc.

## Disengagement Of The PTO Assembly

#### PTO MODELS

- A. To disengage the PTO assembly, move Bagger PTO switch to the off position.

**WARNING:** The PTO assembly blades will continue to spin. DO NOT TOUCH the PTO assembly, pulleys, or the belt until the tractor is turned off. DO NOT adjust the belt tension until the mower is turned off. Refer to the Belt Installation section of the manual.

#### ENGINE DRIVEN MODELS

- B. (Briggs & Stratton 900 Series) To stop the engine, throttle the engine to the stop position.
- C. (6.5HP Briggs & Stratton Vanguard) To stop the engine, move the fuel lever to the OFF position.

### Unloading The Collection System

**NOTE:** To determine when the collection bags are full, follow the following steps:

- A. Stop the forward movement of the mower.
- B. Disengage the mower deck.
- C. Disengage the PTO assembly.
- D. Engage the parking brake.
- E. Once the parking brake has been engaged, then and only then, walk behind the mower and check the collection bags by first unhooking the rubber strap with S-hook that secures the plastic top, then lift the plastic hood. Load in bags should not exceed the height of the installed bag.
- F. To remove the bags from the frame, slide bags out and turn bags over to deposit clippings.
- G. Slide empty bags back onto the frame and secure plastic top with the rubber strap with S-hook.

**NOTE:** Do not allow collection bags to become over-filled as potential damage may occur to your equipment. Also, be sure to clean the hood screen as needed.

## SECTION IV MAINTENANCE

### Maintenance Checklist

Before each use:

1. Check blades and spindles to be sure that no foreign objects, such as wire or steel strapping bands, are wrapped around them.
2. Inspect blades for wear. Replace if necessary. If it is necessary to sharpen the blades, remove the blades from the spindles before sharpening. DO NOT sharpen blades while still attached to the mower.



3. Make sure all shields are in place and in good condition. Repair or replace any missing or damaged shields.
4. Perform lubrication per instructions.
5. Listen for abnormal sounds, which might indicate loose parts, damaged bearings, or other damage. Correct any deficiency before continuing operation.
6. **PTO MODELS ONLY:** With the engine off, engage the blower assembly. Check the belt tension and inspect the pulley belt for cracks or tears.
7. Check for wear or deterioration of the upper or lower hoses. If there are any portions of the hose that have been torn or worn through, replace immediately.

After Each Use:

1. Clean all debris from machine especially from the container, underneath the belt shields, and safety decals. Replace any missing or illegible decals.
2. Inspect the unit for worn or damaged components. Repair or replace before the next use. Any replacement component installed during repair shall include the component's current safety decal specified by the manufacturers to be affixed to the component.
3. Under normal usage, the bag material is subject to deterioration and wear and should therefore be frequently checked for necessary replacement. Any replacement bag should be checked to ensure compliance with the original manufacturer's recommendations or specifications.
4. Check belt for proper tension.

## Lubrication for PTO Models

Gearbox:

**NOTE:** The gearbox is filled with 6.0 oz. of Mobilube HD Plus 80W-90 oil and permanently sealed. There is no need for scheduled lubrication. The oil level should only be checked if a leak is observed or if a change in gearbox noise is noticed.

Operators are recommended to check for leaks weekly. If a leak is observed, both the gasket and the seals are recommended to be replaced.

Replace the oil using 5.5 oz. of the recommended Mobilube HD Plus 80W-90 oil. Be sure to not overfill.

Blower Assembly:

**NOTE:** The following is for older PTO models that contain a greaseable zirc fitting. Newer models contain maintenance-free bearings and are without a greasable fitting.

1. On initial use: Grease the fitting on the blower shaft.
2. Every 25 hours of use: Re-grease the grease fitting.

**NOTE:** Use only white lithium based grease for lubrication of the shaft on the blower assembly.

## SECTION V - PARTS & SERVICE

### 5-1 Parts And Service Information

Collection system owners should record the name and telephone number of their Service Center. Your Service Center will be happy to supply replacement parts, accessories, and do any service or repairs to your collection system. If for any reason your Service Center is unable to service your collection system or supply replacement parts, contact New PECO, Inc. and include the following information on the chart below.

### DOCUMENT THE FOLLOWING INFORMATION FOR FUTURE REFERENCE

**Unit Model Number:** \_\_\_\_\_

**Unit Engine Size:** \_\_\_\_\_

**Unit Serial Number:** \_\_\_\_\_

**Date of purchase:** \_\_\_\_ / \_\_\_\_ / \_\_\_\_

**Dealer/Distributor Name:** \_\_\_\_\_

**Address:** \_\_\_\_\_ **State:** \_\_\_\_\_ **Zip:** \_\_\_\_\_

**Phone Number:** \_\_\_\_\_

**New PECO, Inc.**  
**10 Walden Dr | Arden, North Carolina 28704**  
**Phone: 1-800-438-5823 | 828-684-1234**  
**Fax: 828-684-0858**  
**Email: [peco@lawnvac.com](mailto:peco@lawnvac.com)**  
**Website: [www.lawnvac.com](http://www.lawnvac.com)**



# SAFETY DECALS

To promote safe operation, New PECO, Inc. supplies safety decals on all products manufactured. Damage can occur to safety decals either through shipment, use or reconditioning. Contact your local Service Center for replacement decals.



Part# R1070  
PECO Logo



Part# R0022  
Designed & Built  
In The USA



Part #: R2007  
Danger - Never Use Hands



Part #: R2008  
Danger - Rotating Blades

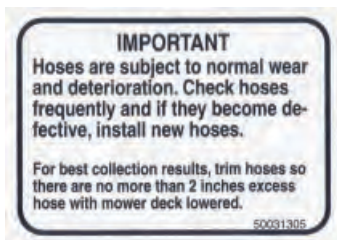

Part #: R1054  
Important - Hose Wear

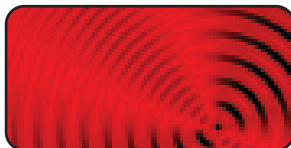
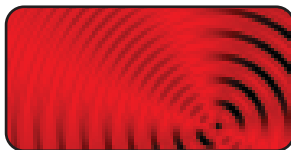

Part #: R1057 - (2)  
Red Reflectors



Part #: R1069  
Warning - Turn Off Blower



Part # R0024  
Danger - Keep Hands  
Clear



Part #: R1051  
Warning - Hearing Protection



Part # R0025  
Danger - Rotating  
Blades

# TORQUE SPECIFICATIONS

Proper torque for American fasteners used on PECO equipment.  
Recommended Torque in Foot Pounds (Newton Meters).\*

## AMERICAN Bolt Head Markings

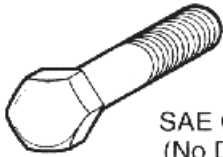

SAE Grade 2  
(No Dashes)

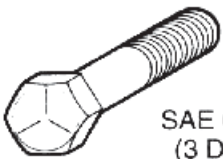

SAE Grade 5  
(3 Dashes)

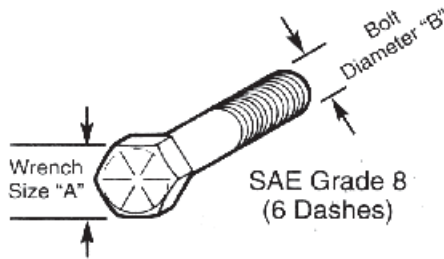

SAE Grade 8  
(6 Dashes)

WRENCH SIZE (IN.) "A"	BOLT DIAMETER (IN.) "B" AND THREAD SIZE	SAE GRADE 2	SAE GRADE 5	SAE GRADE 8
7/16	1/4 - 20 UNC	6 (7)	8 (11)	12 (16)
7/16	1/4 - 28 UNF	6 (8)	10 (13)	14 (18)
1/2	5/16 - 18 UNC	11 (15)	17 (23)	25 (33)
1/2	5/16 - 24 UNF	13 (17)	19 (26)	27 (37)
9/16	3/8 - 16 UNC	20 (27)	31 (42)	44 (60)
9/16	3/8 - 24 UNF	23 (31)	35 (47)	49 (66)
5/8	7/16 - 14 UNC	32 (43)	49 (66)	70 (95)
5/8	7/16 - 20 UNF	36 (49)	55 (75)	78 (106)
3/4	1/2 - 13 UNC	49 (66)	76 (103)	106 (144)
3/4	1/2 - 20 UNF	55 (75)	85 (115)	120 (163)
7/8	9/16 - 12 UNC	70 (95)	109 (148)	153 (207)
7/8	9/16 - 18 UNF	79 (107)	122 (165)	172 (233)
15/16	5/8 - 11 UNC	97 (131)	150 (203)	212 (287)
15/16	5/8 - 18 UNF	110 (149)	170 (230)	240 (325)
1-1/8	3/4 - 10 UNC	144 (195)	266 (360)	376 (509)
1-1/8	3/4 - 16 UNF	192 (260)	297 (402)	420 (569)
1-5/16	7/8 - 9 UNC	166 (225)	430 (583)	606 (821)
1-5/16	7/8 - 14 UNF	184 (249)	474 (642)	668 (905)
1-1/2	1 - 8 UNC	250 (339)	644 (873)	909 (1232)
1-1/2	1 - 12 UNF	274 (371)	705 (955)	995 (1348)
1-1/2	1 - 14 UNF	280 (379)	721 (977)	1019 (1381)
1-11/16	1-1/8 - 7 UNC	354 (480)	795 (1077)	1288(1745)
1-11/16	1-1/8 - 12 UNF	397 (538)	890 (1206)	1444 (1957)
1-7/8	1-1/4 - 7 UNC	500 (678)	1120 (1518)	1817 (2462)
1-7/8	1-1/4 - 12 UNF	553 (749)	1241 (1682)	2013 (2728)
2-1/16	1-3/8 - 6 UNC	655 (887)	1470 (1992)	2382 (3228)
2-1/16	1-3/8 - 12 UNF	746 (1011)	1672 (2266)	2712 (3675)
2-1/4	1-1/2 - 6 UNC	870 (1179)	1950 (2642)	3161 (4283)
2-1/4	1-1/2 - 12 UNF	979 (1327)	2194 (2973)	3557 (4820)

## METRIC

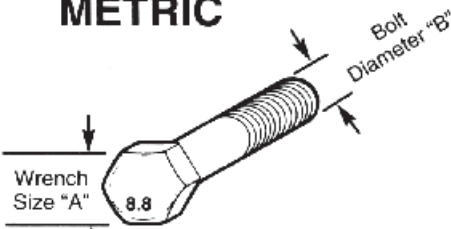

Numbers appearing on bolt heads indicate ASTM class.

Proper torque for metric fasteners used on PECO equipment.  
Recommended torque in foot pounds (newton Meters).\*

WRENCH SIZE (mm) "A"	BOLT DIA. (mm) "B"	ASTM 4.6	ASTM 8.8	ASTM 9.8	ASTM 10.9
8	5	1.8 (2.4)		5.1 (6.9)	6.5 (8.8)
10	6	3 (4)		8.7 (12)	11.1 (15)
13	8	7.3 (10)		21.1 (29)	27 (37)
16	10	14.5 (20)		42 (57)	53 (72)
18	12	25 (34)	74 (100)	73 (99)	93 (126)
21	14	40 (54)	118 (160)	116 (157)	148 (201)
24	16	62 (84)	167 (226)	181 (245)	230 (312)
30	20	122 (165)	325 (440)		449 (608)
33	22		443 (600)		611 (828)
36	24	211 (286)	563 (763)		778 (1054)
41	27		821 (1112)		1138 (1542)
46	30	418 (566)	1119 (1516)		1547 (2096)

\*Use 75% of the specified torque value for plated fasteners. Use 85% of the specified torque values for lubricated fasteners.

**NOTES**



**New PECO, Inc.**  
**10 Walden Dr | Arden, North Carolina 28704**  
**Phone: 1-800-438-5823 | 828-684-1234**  
**Fax: 828-684-0858**  
**Email: [peco@lawnvac.com](mailto:peco@lawnvac.com)**  
**Website: [www.lawnvac.com](http://www.lawnvac.com)**